



US00D945751S

(12) **United States Design Patent**  
**Gavrieli et al.**

(10) **Patent No.:** **US D945,751 S**

(45) **Date of Patent:** **\*\* \*Mar. 15, 2022**

(54) **DUAL-SOLE SHOE WITH STRIPE, COLOR  
OUTSOLE PATCHES, AND CONTRASTING  
UPPER**

(71) Applicant: **Gavrieli Brands LLC**, Beverly Hills,  
CA (US)

(72) Inventors: **Kfir Gavrieli**, Beverly Hills, CA (US);  
**Dikla Gavrieli**, Beverly Hills, CA (US)

(73) Assignee: **Gavrieli Brands LLC**, Beverly Hills,  
CA (US)

(\*) Notice: This patent is subject to a terminal dis-  
claimer.

(\*\*) Term: **15 Years**

(21) Appl. No.: **29/743,751**

(22) Filed: **Jul. 23, 2020**

13/16; A43B 13/18; A43B 13/181; A43B  
13/187; A43B 13/189; A43B 13/20; A43B  
13/22; A43B 13/223; A43B 13/24; A43B  
13/28; A43B 13/30; A43B 13/32; A43B  
13/34; A43B 13/36; A43B 23/00; A43B  
23/02; A43B 23/04; A43B 23/07; A43B  
23/024; A43B 23/0245; A43B 23/025;  
A43B 23/026; A43B 23/265; A43B  
23/14; A43B 23/16; A43B 23/24; A43B  
23/26; A43B 5/00; A43B 5/001; A43B  
5/002; A43B 5/003; A43B 5/008; A43B  
5/06; A43B 5/08; A43B 5/10; A43B 5/12;  
A43B 5/14; A43B 5/145; A43B 1/00;  
A43B 1/02; A43B 1/04; A43B 1/0045;  
A43B 3/12; A43B 7/00; A43B 9/00;  
A43B 9/08; A43B 9/14; A43B 9/16;  
A43B 11/00; A43B 21/00; A43B 21/02;  
A43B 21/04; A43B 21/06; A43C 1/00;  
A43C 1/003; A43C 1/06; A43C 3/00;  
A43C 5/00; A43C 7/00; A43C 11/00

See application file for complete search history.

**Related U.S. Application Data**

(63) Continuation of application No. 15/905,239, filed on  
Feb. 26, 2018, now abandoned, which is a  
continuation of application No. 15/204,763, filed on  
Jul. 7, 2016, now Pat. No. 9,930,925, which is a  
continuation of application No. 14/266,599, filed on  
Apr. 30, 2014, now Pat. No. 9,398,786, which is a  
continuation of application No. 13/207,397, filed on  
Aug. 10, 2011, now Pat. No. 8,745,893.

(51) **LOC (13) Cl.** ..... **02-04**

(52) **U.S. Cl.**  
USPC ..... **D2/939**

(58) **Field of Classification Search**  
USPC ..... D2/902, 896, 900, 904, 906–908,  
D2/916–962, 969, 970–979; 36/1, 1.5,  
36/3 B, 22 R, 24.5, 25 R, 28, 32 R, 34 R,  
36/59 C, 67 A, 101–107, 117.3, 117.4,  
36/124–136, 3 A, 83, 45, 99, 112–116  
CPC ..... A43B 13/00; A43B 13/02; A43B 13/023;  
A43B 13/026; A43B 13/04; A43B 13/08;  
A43B 13/10; A43B 13/12; A43B 13/14;  
A43B 13/141; A43B 13/143; A43B

(56)

**References Cited**

U.S. PATENT DOCUMENTS

249,086 A	11/1881	Pienovi
773,850 A	11/1904	Cooper et al.
830,941 A	9/1906	Walden
1,208,209 A	12/1916	Prince
1,214,666 A	2/1917	Ford
1,519,009 A	12/1924	Reina
1,525,848 A	2/1925	Bonaventure
1,587,377 A	6/1926	Grosjean
1,650,466 A	11/1927	Righter
2,224,590 A	12/1940	Boivin
2,268,777 A	1/1942	Scholl
D133,819 S	9/1942	Harris
D135,791 S	6/1943	Beebe
2,323,563 A	7/1943	Nugent
2,342,882 A	2/1944	Meltzer
D141,871 S	7/1945	Braun
2,383,585 A	8/1945	Bindner
D149,685 S	5/1948	Sandler
D150,729 S	8/1948	Sandler
D166,090 S	3/1952	Maling
2,772,488 A	12/1956	Meltzer
2,904,814 A	9/1959	Scholl
3,148,378 A	9/1964	Tibbitts

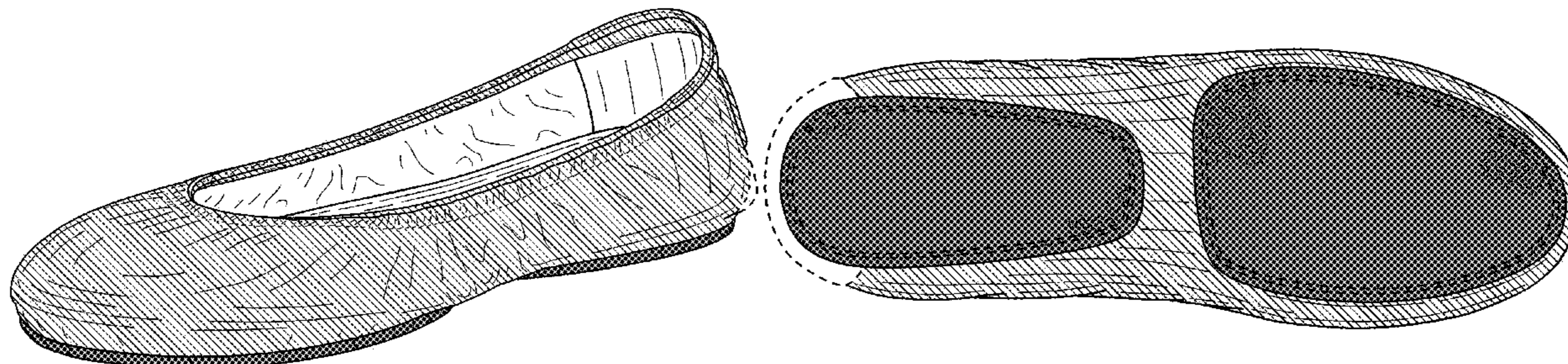



# US D945,751 S

D200,897 S	4/1965	Mitchell	8,240,067 B2	8/2012	Sussmann	
D220,464 S	4/1971	Hayoshi	8,245,420 B2	8/2012	Wilson	
D247,396 S	3/1978	Schlerth	D668,027 S	10/2012	Millieret	
4,412,393 A	11/1983	Terlizzi, Jr. et al.	D668,438 S	10/2012	Millieret	
D275,525 S	9/1984	Nakao	D668,847 S	10/2012	Gavrieli et al.	
4,674,206 A	6/1987	Lyden	D668,848 S	10/2012	Gavrieli et al.	
D295,692 S	5/1988	Zuidema et al.	D668,849 S	10/2012	Pozzi	
D300,085 S	3/1989	Ito et al.	D668,850 S	10/2012	Pozzi	
RE33,018 E	8/1989	Ostrander	D672,542 S	12/2012	Gray et al.	
4,899,412 A	2/1990	Ganon	D672,550 S	12/2012	Gavrieli	
D316,773 S	5/1991	Valle	D672,552 S	12/2012	Gavrieli	
5,012,541 A	5/1991	Ganon	D676,634 S	2/2013	Gavrieli et al.	
D339,669 S	9/1993	Miller	D680,007 S	4/2013	Gavrieli	
5,282,326 A	2/1994	Schroer, Jr. et al.	D681,927 S	5/2013	Gavrieli	
5,421,050 A	6/1995	Laganas	D681,928 S	5/2013	Gavrieli	
5,699,629 A	12/1997	Munschy	D681,929 S	5/2013	Gavrieli	
5,746,014 A	5/1998	Tanemoto	D683,936 S	6/2013	Gavrieli	
D420,785 S	2/2000	Perez	8,468,723 B2	6/2013	Malka-Harari	
6,055,745 A	5/2000	Endoh	D686,812 S	7/2013	Gavrieli et al.	
6,076,284 A	6/2000	Terlizzi	8,510,975 B2	8/2013	Krikelis	
6,189,239 B1	2/2001	Gasparovic et al.	D688,853 S	9/2013	Gavrieli	
6,338,207 B1	1/2002	Chang	D688,854 S	9/2013	Gavrieli	
D457,292 S	5/2002	Sessa	D688,855 S	9/2013	Gavrieli	
D461,947 S	8/2002	Merceron	D689,270 S	9/2013	Gavrieli	
6,588,124 B2	6/2003	Morrone	D689,271 S	9/2013	Gavrieli	
D476,798 S	7/2003	Reynolds et al.	D689,272 S	9/2013	Gavrieli	
D498,041 S	11/2004	McClaskie	D690,914 S	10/2013	Gavrieli	
D500,191 S	12/2004	Belley et al.	D690,915 S	10/2013	Gavrieli	
D501,706 S	2/2005	McClaskie	D696,500 S	12/2013	Hunt	
6,857,203 B2	2/2005	Minden	D699,424 S	2/2014	Hamm	
6,895,693 B2	5/2005	Baruck	8,661,714 B2	3/2014	Sussman	
6,978,557 B2	12/2005	Lee	D703,531 S	4/2014	Gavrieli et al.	
7,032,327 B1	4/2006	Tartaglia et al.	8,745,893 B2	6/2014	Gavrieli et al.	
7,036,244 B1	5/2006	Finch	8,973,287 B2	3/2015	Shibata	
D527,513 S	9/2006	Della Valle	D730,635 S *	6/2015	Lin .....	D2/939
D529,513 S	10/2006	Aketa	D747,595 S	1/2016	Gavrieli	
D531,790 S	11/2006	Wurzburg	D749,829 S	2/2016	Gavrieli	
D534,341 S	1/2007	Choi	D749,830 S	2/2016	Gavrieli	
D542,513 S	5/2007	Amado et al.	D750,360 S	3/2016	Gavrieli	
D556,990 S	12/2007	Cabados	D750,361 S	3/2016	Gavrieli	
7,337,558 B2	3/2008	Terlizzi et al.	D750,872 S	3/2016	Gavrieli	
D567,485 S	4/2008	James	D750,873 S *	3/2016	Gavrieli .....	D2/939
D570,488 S	6/2008	Kirksey et al.	D750,874 S *	3/2016	Gavrieli .....	D2/939
D571,084 S	6/2008	Comeau	D751,278 S *	3/2016	Gavrieli .....	D2/939
D571,548 S	6/2008	Seamans	D751,279 S *	3/2016	Gavrieli .....	D2/939
D571,989 S	7/2008	Siegal	D755,485 S	5/2016	Gavrieli	
D580,640 S	11/2008	Wurzburg	D755,486 S	5/2016	Gavrieli	
D582,638 S	12/2008	Ringholz	D755,487 S	5/2016	Gavrieli	
7,496,982 B2	3/2009	Clark et al.	D755,488 S	5/2016	Gavrieli	
7,506,459 B2	3/2009	Grisoni et al.	D756,081 S	5/2016	Gavrieli	
D591,031 S	4/2009	Cofinco	D756,082 S	5/2016	Gavrieli	
D593,295 S	6/2009	Belley et al.	D756,083 S	5/2016	Gavrieli	
D593,297 S	6/2009	Belley et al.	D756,084 S	5/2016	Gavrieli	
D593,307 S	6/2009	Belley et al.	D756,087 S	5/2016	Gavrieli	
D599,093 S	9/2009	Issler	D757,407 S	5/2016	Gavrieli	
D604,030 S	11/2009	Wilson	D758,052 S	6/2016	Gavrieli	
D607,194 S	1/2010	Zagula	D758,053 S	6/2016	Gavrieli	
D610,332 S	2/2010	Raichle	D761,529 S	7/2016	Gavrieli	
D610,785 S	3/2010	Smith	D761,530 S	7/2016	Gavrieli	
D612,140 S	3/2010	Moon	D761,531 S	7/2016	Gavrieli	
D612,141 S	3/2010	Moon	D761,532 S	7/2016	Gavrieli	
7,694,435 B1	4/2010	Kiser et al.	D761,533 S	7/2016	Gavrieli	
D615,737 S	5/2010	Feller	D761,534 S	7/2016	Gavrieli	
7,735,244 B1	6/2010	Ameche	D761,535 S	7/2016	Gavrieli	
7,743,530 B2	6/2010	Truelsen	D761,536 S	7/2016	Gavrieli	
D618,891 S	7/2010	McClaskie	D761,537 S	7/2016	Gavrieli	
7,757,408 B2	7/2010	McClaskie	D761,538 S	7/2016	Gavrieli	
D630,829 S	1/2011	Weisner	D761,539 S	7/2016	Gavrieli	
D632,881 S	2/2011	Rosenberg	D762,050 S	7/2016	Gavrieli	
7,926,203 B2	4/2011	Wilkenfeld	9,398,786 B2	7/2016	Gavrieli et al.	
7,966,747 B2	6/2011	Wilkenfeld et al.	D763,556 S	8/2016	Gavrieli	
D640,861 S	7/2011	Wilkenfeld	D763,557 S	8/2016	Gavrieli	
8,020,320 B2	9/2011	Gillespie	D764,154 S	8/2016	Gavrieli	
8,127,468 B2	3/2012	Morgan	D771,919 S	11/2016	Gavrieli	
D657,543 S	4/2012	Bove	D771,920 S	11/2016	Gavrieli	
D659,960 S	5/2012	Bizzo	D775,798 S	1/2017	Gavrieli	
8,230,619 B2	7/2012	Salvatelli	D779,798 S	2/2017	Gavrieli	
D664,755 S	8/2012	Gavrieli et al.	D779,799 S	2/2017	Gavrieli	
D665,157 S	8/2012	Wu	D779,800 S	2/2017	Gavrieli	



# US D945,751 S

D779,801 S	2/2017	Gavrieli		2003/0070319 A1	4/2003	Minden
D781,032 S	3/2017	Gavrieli		2003/0121176 A1	7/2003	Baruck
D781,033 S	3/2017	Gavrieli		2004/0025377 A1	2/2004	Brannon
D781,034 S	3/2017	Gavrieli		2005/0022421 A1	2/2005	Bruckner
D781,035 S	3/2017	Gavrieli		2005/0115115 A1	6/2005	Lacey
D782,167 S	3/2017	Gavrieli		2005/0217148 A1	10/2005	Connolly et al.
D790,336 S	6/2017	Gavrieli		2005/0262734 A1	12/2005	Cheng
D799,169 S *	10/2017	Abramowitz	..... D2/902	2006/0086005 A1	4/2006	Yerian
D805,277 S	12/2017	Gavrieli		2006/0156576 A1	7/2006	Sloan
D812,867 S	3/2018	Gavrieli		2007/0074424 A1	4/2007	Lin
D812,868 S	3/2018	Gavrieli		2007/0204482 A1	9/2007	Gibson-Collinson
D814,153 S	4/2018	Gavrieli		2007/0204483 A1	9/2007	Kirsch et al.
9,930,925 B2	4/2018	Gavrieli et al.		2008/0052964 A1	3/2008	Taylor
D818,684 S	5/2018	Gavrieli		2008/0086912 A1	4/2008	Wilkenfeld
D818,692 S	5/2018	Gavrieli		2008/0110059 A1	5/2008	Kuramoto et al.
D819,313 S	6/2018	Gavrieli		2009/0019732 A1	1/2009	Sussmann
D819,321 S	6/2018	Gavrieli		2009/0193685 A1	8/2009	Wilson
D819,940 S	6/2018	Gavrieli		2009/0205222 A1	8/2009	Mclinden
D824,148 S	7/2018	Gavrieli		2009/0272009 A1	11/2009	Weisner et al.
D824,149 S	7/2018	Gavrieli		2010/0011625 A1	1/2010	Percival
D824,150 S	7/2018	Gavrieli		2010/0018080 A1	1/2010	Smith
D824,655 S	8/2018	Gavrieli		2010/0050469 A1	3/2010	Chen
D824,656 S	8/2018	Gavrieli		2010/0095557 A1	4/2010	Jarvis
D825,155 S	8/2018	Gavrieli		2010/0115793 A1	5/2010	Kraisosky
D825,156 S	8/2018	Gavrieli		2010/0122475 A1	5/2010	Purrrington
D825,160 S	8/2018	Gavrieli		2010/0146822 A1	6/2010	MacGregor
D826,524 S	8/2018	Gavrieli		2010/0212186 A1	8/2010	Cheng
D831,312 S	10/2018	Gavrieli		2010/0275462 A1	11/2010	Pucci
D837,495 S	1/2019	Gavrieli		2010/0281713 A1	11/2010	Pantazes
D842,593 S	3/2019	Gavrieli		2013/0036630 A1 *	2/2013	Gavrieli ..... A43B 23/0245 36/102
D843,092 S	3/2019	Gavrieli				
D843,093 S	3/2019	Gavrieli		2013/0039605 A1 *	2/2013	Gavrieli ..... A45C 3/12 383/37
D843,094 S	3/2019	Gavrieli				
D844,305 S	4/2019	Gavrieli		2015/0089843 A1	4/2015	Gavrieli
D844,312 S	4/2019	Gavrieli				
D844,950 S	4/2019	Gavrieli				
D844,951 S	4/2019	Gavrieli				
D846,240 S	4/2019	Gavrieli				
D846,246 S	4/2019	Gavrieli				
D846,258 S	4/2019	Gavrieli				
D846,259 S	4/2019	Gavrieli				
D846,844 S	4/2019	Gavrieli				
D846,845 S	4/2019	Gavrieli				
D846,846 S	4/2019	Gavrieli				
D846,847 S	4/2019	Gavrieli				
D846,848 S	4/2019	Gavrieli				
D846,849 S	4/2019	Gavrieli				
D846,860 S	4/2019	Gavrieli				
D847,474 S	5/2019	Gavrieli				
D847,476 S	5/2019	Gavrieli				
D851,872 S *	6/2019	Gavrieli	..... D2/939			
D853,091 S *	7/2019	Gavrieli	..... D2/939			
D853,092 S *	7/2019	Gavrieli	..... D2/939			
D853,697 S *	7/2019	Gavrieli	..... D2/939			
D853,698 S *	7/2019	Gavrieli	..... D2/939			
D856,641 S *	8/2019	Tewani	..... D2/919			
D859,792 S *	9/2019	Subatella	..... D2/902			
D868,433 S *	12/2019	Glickfield	..... D2/909			
D884,323 S *	5/2020	Gavrieli	..... D2/951			
D885,018 S *	5/2020	Gavrieli	..... D2/939			
D885,717 S *	6/2020	Radabaugh	..... D2/939			
D886,421 S *	6/2020	Gavrieli	..... D2/939			
D889,081 S *	7/2020	Gavrieli	..... D2/939			
D889,785 S *	7/2020	Gavrieli	..... D2/939			
D890,483 S *	7/2020	Gavrieli	..... D2/939			
D891,047 S *	7/2020	Gavrieli	..... D2/939			
D901,148 S *	11/2020	Gavrieli	..... D2/950			
D901,858 S *	11/2020	Gavrieli	..... D2/950			
D901,860 S *	11/2020	Gavrieli	..... D2/950			
D901,861 S *	11/2020	Gavrieli	..... D2/950			
D901,862 S *	11/2020	Gavrieli	..... D2/950			
D901,863 S *	11/2020	Gavrieli	..... D2/950			
D901,871 S *	11/2020	Gavrieli	..... D2/971			
D903,988 S *	12/2020	Gavrieli	..... D2/939			
D903,989 S *	12/2020	Gavrieli	..... D2/939			
D924,550 S *	7/2021	Kerrigan	..... D2/969			
11,071,342 B2 *	7/2021	Rola	..... A41F 13/00			
2002/0078591 A1	6/2002	Morrone				
2002/0129519 A1	9/2002	Cahan				

## FOREIGN PATENT DOCUMENTS

DE	20 2006 000230 U1	5/2007
GB	2443937 A	5/2008
GB	2 446 205 A	8/2008
TW	D119165	10/2007

## OTHER PUBLICATIONS

U.S. Appl. No. 29/750,872, filed Mar. 15, 2016, Gavrieli, Kfir.

Letter from TMI and Associates with Office Action, 2 pgs, dated Sep. 19, 2012 <http://www.payless.com/store/?&TLC=Womens&SLC=WomensNewrivals&BLC=WomensNewrivalsNewArrivals&With+Regular&ItemCodec=60131&LotNumber=062642&Type=Adult&Popularity=637&Descriptvein>.

Taiwanese Office Action for TW 101300726, 10 pgs., dated Sep. 6, 2012.

“The Love List, Ticks by Gavrieli—Foldable Ballet Flats,” <http://thelovelist-carlyblogspot.com.au/2010/09/ticks-by-gavrieli-foldable-ballet.html>, 2 pgs., Sep. 12, 2010.

“Ticks by Gavrieli,” <http://ticks.com>, 1 pg., retrieved Mar. 13, 2013 from URL.

“Try It Mummy!, Ticks by Gavrieli,” <http://tryitmummy.blogspot.com.au/2010/12/ticks-by-gavrieli.html>, 3 pgs., Dec. 9, 2010.

“Wearability—Real People Style, What came first, the City Flat or the Ticks,” <http://wearability.posterous.com/what-came-first-the-city-flat-or-the-ticks>, 2 pgs., Aug. 29, 2010.

“The Ballet Flat . . . Reinvented; Ballet Flats . . . with a Bonus; Step Into Ticks; Going Places? Take Ticks,” <http://web.archive.org/web/2010052004346/http://www.ticks.com/>; 4 pgs., May 24, 2010.

“Ticks—Comfortable designer flats you can fit in your purse and wear all day, every day,” <http://web.archive.org/web/20110731151555/http://ticks.com/>; 6 pgs., Jul. 31, 2011.

“58th Annual Emmy Awards,” [http://spoonsforksandfashion.blogspot.com/2006\\_08\\_01\\_archive.html](http://spoonsforksandfashion.blogspot.com/2006_08_01_archive.html), depicting. Nine West flats, 2 pgs., Aug. 1, 2006.

Pictures of Nine West flats sold in 2006, 3 pgs.

“I Love a Good Ballet Flat!,” <http://dressupfiles.com/i-love-a-200d-ballet-flat>, depicting Sue London flats, 3 pgs., Sep. 3, 2010.

Pictures of Sue London flats sold in 2010, 2 pgs.



- “Miss Cathie Reviews: The Yosi Samra Foldable Ballet Flat . . .,” <http://www.misscathie.com/2010/01/miss-cathie-reviews-the-yosi-samra-foldable-ballet-flat/>, depicting Yosi Samra flats, 9 pgs., Jan. 2010.
- Pictures of Yosi Samra flats sold in 2010, 2 pgs.
- “Goodbye two thousand ten,” [http://emmajoyrussell.blogspot.com/2010\\_12\\_01\\_archive.html](http://emmajoyrussell.blogspot.com/2010_12_01_archive.html), depicting Gap flats, 39 pgs., Dec. 1, 2010.
- Pictures of Gap flats available for sale in 2010, 9 pgs.
- “Our newest design of folding flats-Pink,” <https://fitinclouds.wordpress.com/2010/05/16/our-newest-design-of-folding-flats-pink/>, depicting Fit in Clouds flats, 1 pg., May 16, 2010.
- “Fit in Clouds Satin Folding Shoes,” <http://www.goodhousekeeping.com/product-reviews/clothing/best-ballet-flats/fit-in-clouds-satin-foldable-ballet-flats>, depicting Fit in Clouds flats, 2 pg., Aug. 2013.
- Pictures of Fit in Clouds flats available for sale in 2011, 4 pgs.
- “Shoes for Standing,” <https://truthinshoes.wordpress.com/2008/07/>, depicting Sam & Libby flats, 2 pgs., Jul. 31, 2008.
- “Target Designer Collaboration: Announcing Sam & Libby Shoes for Target,” <http://www.therecessionista.com/2012/11/target-designer-collaboration-announcing-sam-libby-shoes-for-target.html>, depicting Sam & Libby flats, 1 pg., Nov. 26, 2012.
- Pictures of Sam & Libby flats available for purchase in 2011, 5 pgs.
- “Save your soles with Citisoles ballet flats,” <http://glamazondiaries.com/2009/07/save-your-soles-with-citisoles-ballet-flats>, depicting Citisoles flats, 3 pgs., Jul. 2009.
- Pictures of Citisoles flats available for purchase in 2009, 3 pgs.
- “#16 Corso Como Delicious Pumps Review and Giveaway!,” <http://www.mommatoldmeblog.com/2011/01/16-corso-como-delicious-pumps-review.html>, depicting Corso Como flats, 8 pgs., Jan. 16, 2011.
- Pictures of Corso Como flats available for sale in 2011, 3 pgs.
- “Jil-sander-navy-lead-ballet-flats-product . . .,” [www.ebay.com](http://www.ebay.com), depicting Jil Sander flats, 4 pgs., Nov. 2013.
- Pictures of Jil Sander flats available for sale in 2011, 3 pgs.
- “Spare Soles: Shoes That Roll-up & Fold-up,” <http://herpackinglist.com/2011/01/spare-soles-shoes/>, depicting Spare Soles flats, 2 pgs., Jan. 2011.
- Pictures of Spare Soles flats available for sale in 2011, 5 pgs.
- Pictures of Roll-Upz by Spare Soles flats available for sale in 2011, 6 pgs.
- “The Cutest Blog, Preppy 50 and Loving Lilly, Ballet Flat Delight,” <http://preppy50andlovinglilly.blogspot.com/2011/02/ballet-flat-delight.html>, depicting Henri Bendel flats, 1 pg., Feb. 19, 2011.
- Pictures of Henri Bendel flats available for sale in 2011, 4 pgs.
- “Mumsnet by parents for parents,” [http://www.momsnet.com/Talk/style\\_and\\_beauty/a1612000-Anyone-tried-Redfoot-Flatmates-foldable-ballet-pamps](http://www.momsnet.com/Talk/style_and_beauty/a1612000-Anyone-tried-Redfoot-Flatmates-foldable-ballet-pamps), depicting Redfoot Flatmates flats, 1 pg, Nov. 14, 2012.
- Pictures of Redfoot Flatmates flats available for sale in 2011, 6 pgs.
- “Amazon.com: Customer Reviews: Bloch London Women’s Lux Ballet Flat,” <http://www.amazon.com/Bloch-London-Womens-Ballet-Flat/product-reviews/B004LWPTYW>, depicting Bloch London flats, 4 pgs., Dec. 11, 2011.
- Pictures of Bloch London flats offered for sale in 2011, 11 pgs.
- “h&m foldable leopard print flat,” <https://8485shops.wordpress.com/2011/06/16/flats-for-7-bucks/shoe1/>, depicting h&m flats, 2 pgs., Jun. 16, 2011.
- Pictures of h&m foldable flats offered for sale in 2011, 4 pgs.
- “Seekyt—Juicy Couture Ballet Flats—Are They Worth The Money?,” <http://seekyt.com/juicy-couture-ballet-flats-are-they-worth-the-money/>, 2 pgs., Jun. 3, 2011.
- Pictures of Juicy Couture flats offered for sale in 2011, 3 pgs.
- “Purse Flats,” <http://purseflats.wordpress.com>, depicting Purse Flats by Erica Wilson, 3 pgs., Jul. 12, 2012.
- Pictures of Purse Flats by Erica Wilson offered for sale in 2011, 6 pgs.
- “Ticks by Gavrieli—Comfortable, designer flats you can fit in your purse and wear all day . . .,” <http://web.archive.org/web/20110202210649/http://www.tieks.com/>, 8 pgs., Feb. 2, 2011.
- “Carolina M. M. Gonzalez > Ticks by Gavrieli,” [1262332800\\_8\\_17&timeend=1293868799&timestart=1262332800&tm=AQDOvqhWQPN\\_Nbwm&refid=17](http://m2.facebook.com/Tieks?v=timeline&filter=2&timecutoff=1406427986&page=17&sectionLoadingID=m_timeline_loading_div_1293868799_1262332800_8_17&timeend=1293868799&timestart=1262332800&tm=AQDOvqhWQPN_Nbwm&refid=17), 1 pg. Jan. 26, 2010.
- “The Shoes Oprah Would Wear to Work (if She Had to Walk),” <http://www.inc.com/30under30/christina-desmarais/kfir-gavrieli-and-elram-gavrieli-founders-of-tieks.html>, 2 pgs., Jul. 2, 2012.
- “Ticks by Gavrieli,” [http://m2.facebook.com/Tieks?v=timeline&filter=2&timecutoff=1406427986&page=14&sectionLoadingID=m\\_timeline\\_loading\\_div\\_1293868799\\_1262332800\\_8\\_14&timeend=1293868799&timestart=1262332800&tm=AQDOvqhWQPN\\_Nbwm&refid=17](http://m2.facebook.com/Tieks?v=timeline&filter=2&timecutoff=1406427986&page=14&sectionLoadingID=m_timeline_loading_div_1293868799_1262332800_8_14&timeend=1293868799&timestart=1262332800&tm=AQDOvqhWQPN_Nbwm&refid=17), 4 pgs., Jan. 26, 2010.
- “Mighty Life List, Sensible Shoes,” <http://mightygirl.com/2010/08/24/sensible-shoes/>, 11 pgs., Aug. 24, 2010.
- “Find! Ticks: Fab & sexy flats for fall,” <http://thefabmom.com/2013/08/29/find-tieks-fab-sexy-flats-for-fall/>, 3 pgs. Aug. 29, 2013.
- “Step into Ticks,” <http://sliceofpink.typepad.com/blog/2010/09/tieks-1.html>, 5 pgs., Sep. 22, 2010.
- “In Need of Flat-Soled Shoes,” <http://www.kellywickham.com/mochamomma/2010/10/4/in-need-of-flat-soled-shoes.html>, 4 pgs., Oct. 3, 2010.
- “Say Hello to the Flat Shoes You Need for Fall . . . All 88 of Them!”, Picture of Adam Tucker Shoe/Slipper, <https://www.facebook.com/search/top?q=adam%20shoes%20slipper>, last accessed Oct. 28, 2016, dated Oct. 1, 2013, 1 page.
- Picture of Adam Tucker Rainbow Shoes, <https://www.facebook.com/search/top?q=adam%20shoes%20rainbow>, last accessed Oct. 28, 2016, dated Aug. 14, 2013, 1 page.
- Third Party Submission Under 37 CFR 1.290 regarding U.S. Appl. No. 15/905,239, filed Feb. 9, 2019, 94 pages.
- Order Granting TRO (D.I. 11), Gavrieli Brands LLC vs. Soto Massini, Civil Action No. 1:18-cv-00462, Mar. 28, 2018, 2 pages.
- Defendants’ Opposition To Motion For Temporary Restraining Order, Civil Action No. 1:18-cv-00462-GMS, Apr. 1, 2018, 12 pages.
- Declaration of Thomas Pichler In Opposition To Tro Request, C.A. No. 1:18-cv-00462-GMS, Apr. 1, 2018, 8 pages.
- Exhibit A to Pichler Declaration ISO TRO Opposition (D.I. 13-1), C.A. No. 1:18-cv-00462-GMS, Apr. 1, 2018, 29 pages.
- Order TRO (D.I. 18), C.A. No. 1:18, Apr. 4, 2018, 3 pages.
- Defendant Soto Massini (USA) Corporation’s Answer and Counterclaims To Verified Complaint for Patent Infringement, Trade Dress Infringement, and Unfair Competition, C.A. No. 1:18-cv-00462-GMS, May 1, 2018, 26 pages.
- Defendant Soto Massini (USA) Corporation’s Answer To Amended Complaint and Amended Counterclaims, C.A. No. 1:18-cv-00462-GMS, Jun. 5, 2018, 28 pages.
- Defendant Soto Massini (USA) Corporation’s Answer To Amended Complaint and First Amended Counterclaims, C.A. No. 1:18-cv-00462-GMS, Jul. 12, 2018, 31 pages.
- Exhibit A to SACC (45-1), Case 1:18-cv-00462-GMS, 3 pages.
- Exhibit B to SACC (45-2), Case 1:18-cv-00462-GMS, 5 pages.
- Exhibit C to SACC (45-3), Case 1:18-cv-00462-GMS, 5 pages.
- Exhibit D to SACC (45-4), Case 1:18-cv-00462-GMS, 4 pages.
- Defendant Soto-USA’s Invalidity Contentions, C.A. No. 1:18-cv-00462-MN, 16 pages.
- Redacted Verdict Form (D.I. 144), Case 1:18-cv-00462-GMS, 13 pages.
- Judgement (D.I. 149), C.A. No. 18-462-MN, May 13, 2019, 3 pages.
- Gavrieli Brands, LLC, v. Soto Massini (USA) Corp., et al.*, (full) Trial Transcript, C.A. No. 18-462(MN), vol. 1, 733 pages.
- Expert Report of Caroline de Baere (Fed. R. CIV. P. 26(a)(2)(B)), Case No. 18-cv-00462-MN, Mar. 1, 2019, 33 pages.
- Exhibit 23, Infringement Analysis in Light of the Alleged Prior Art, 41 pages.
- Expert Report of Lance Rake, (Fed. R. CIV. P. 26(a)(2)(B)), Mar. 1, 2019, 27 pages.
- U.S. Pat. No. 1,525,848, Feb. 10, 1925, B. S. Bonaventure, 3 pages.
- Design U.S. Pat. No. 247,396, Mar. 7, 1978, William A. Schlerth, 2 pages.
- Design U.S. Pat. No. D. 611,693 S, Mar. 16, 2010, Barbara Schwartz, 7 pages.
- Camper Book Excerpt—Nina Right, (pp. 334-335), The Walking Society, Lars Muller Publishers, 3 pages.



Camper History—The Shoes, Every Season We Strive To Reinvent Some Of Our Classic Concepts While Continuing To Challenge The Status Quo With New And Original Designs. We Often Find That There Is A Camper Style For Every Walk Of Life, 8 pages.

Tieks by Gavrieli—Comfortable, designer flats you can fit in your purse and wear all day, every day!, Copperhead Snake Print Tieks, <https://web.archive.org/web/20101230062534/http://www.tieks.com:80/>, Dec. 30, 2010, 1 page.

Tieks by Gavrieli—Comfortable, designer flats you can fit in your purse and wear all day, every day!, Merlot Lizard Print Tieks, <https://web.archive.org/web/20101230062534/http://www.tieks.com:80/>, Dec. 30, 2010, 1 page.

Tieks by Gavrieli—Comfortable, designer flats you can fit in your purse and wear all day, every day!, Slate Grey Tieks, <https://web.archive.org/web/20101230062534/http://www.tieks.com:80/>, Dec. 30, 2010, 1 page.

Tieks by Gavrieli—Comfortable, designer flats you can fit in your purse and wear all day, every day!, Camel, <https://web.archive.org/web/20101230062534/http://www.tieks.com:80/>, Dec. 30, 2010, 1 page.

Tieks by Gavrieli—Comfortable, designer flats you can fit in your purse and wear all day, every day!, Lilac, <https://web.archive.org/web/20101230062534/http://www.tieks.com:80/>, Dec. 30, 2010, 1 page.

Tieks by Gavrieli—Comfortable, designer flats you can fit in your purse and wear all day, every day!, Leopard Print, <https://web.archive.org/web/20101230062534/http://www.tieks.com:80/>, Dec. 30, 2010, 1 page.

Tieks by Gavrieli—Comfortable, designer flats you can fit in your purse and wear all day, every day!, The Tieks eGift card . . . Always the perfect fit, <https://web.archive.org/web/20101230062534/http://www.tieks.com:80/>, Dec. 30, 2010, 1 page.

Tieks by Gavrieli—Comfortable, designer flats you can fit in your purse and wear all day, every day!, Copperhead Snake Print, <https://web.archive.org/web/20110222174850/http://www.tieks.com:80/>, Feb. 22, 2011, 1 page.

Tieks by Gavrieli—Comfortable, designer flats you can fit in your purse and wear all day, every day!, Patent Tiek Blue, <https://web.archive.org/web/20110222174850/http://www.tieks.com:80/>, Feb. 22, 2011, 1 page.

Tieks by Gavrieli—Comfortable, designer flats you can fit in your purse and wear all day, every day!, Tangerine, <https://web.archive.org/web/20110222174850/http://www.tieks.com:80/>, Feb. 22, 2011, 1 page.

Tieks by Gavrieli—Fashionable Flats That Fit in Your Purse California Navy, <https://web.archive.org/web/20100516173039/http://www.tieks.com:80/california-navy.html>, May 16, 2010, 1 page.

Tieks by Gavrieli—Fashionable Flats That Fit in Your Purse Cardinal Red, <https://web.archive.org/web/20100516173045/http://www.tieks.com:80/cardinal-red.html>, May 16, 2010, 1 page.

Tieks by Gavrieli—Fashionable Flats That Fit in Your Purse Metallic Gold, <https://web.archive.org/web/20100516173106/tieks.com/metallic-gold.html>, May 16, 2010, 1 page.

Tieks by Gavrieli—Fashionable Flats That Fit in Your Purse Patent Tiek Blue, <https://web.archive.org/web/20100516173130/http://www.tieks.com:80/tiek-blue.html>, May 16, 2010, 1 page.

Tieks by Gavrieli—Fashionable Flats That Fit in Your Purse Splash Page, The Ballet Flat . . . Reinvented, <https://web.archive.org/web/20100513055818/https://tieks.com/>, May 13, 2010, 1 page.

Tieks by Gavrieli—Fashionable Flats That Fit in Your Purse Splash Page, Ballet Flats . . . with a Bonus, <https://web.archive.org/web/20100513055818/https://tieks.com/>, May 13, 2010, 1 page.

Tieks by Gavrieli—Fashionable Flats That Fit in Your Purse Splash Page, Going Places? Take Tieks. <https://web.archive.org/web/20100513055818/https://tieks.com/>, May 13, 2010, 1 page.

Tieks by Gavrieli—Fashionable Flats That Fit in Your Purse Splash Page, Step Into Tieks, <https://web.archive.org/web/20100513055818/https://tieks.com/>, May 13, 2010, 1 page.

Tieks by Gavrieli—Fashionable Flats That Fit in Your Purse True Blue, <https://web.archive.org/web/20100516173135/http://www.tieks.com:80/true-blue.html>, May 16, 2010, 1 page.

Tieks by Gavrieli—Fashionable Flats That Fit in Your Purse White Croc Print, <https://web.archive.org/web/20100516173145/http://www.tieks.com:80/white-croc-print.html>, May 16, 2010, 1 page.

Tieks by Gavrieli—Foldable Fashionable Ballet Flats, Wild Copper, Be a little wild . . . even when you're not., <https://web.archive.org/web/20100819165503/https://tieks.com/>, Aug. 19, 2010, 1 page.

Tieks by Gavrieli—Foldable Fashionable Ballet Flats, Paradise Blue, The perfect pair for day and night, <https://web.archive.org/web/20100819165503/https://tieks.com/>, Aug. 19, 2010, 1 page.

Tieks by Gavrieli—Foldable Fashionable Ballet Flats, Obsidian Black, When workdays spill over into party nights., <https://web.archive.org/web/20100819165503/https://tieks.com/>, Aug. 19, 2010, 1 page.

Tieks by Gavrieli—Foldable Fashionable Ballet Flats, Fuchsia, Sweet and sultry, <https://web.archive.org/web/20100819165503/https://tieks.com/>, Aug. 19, 2010, 1 page.

Tieks by Gavrieli—Foldable Fashionable Ballet Flats, Tan Croc print Tieks, A timeless texture., <https://web.archive.org/web/20100819165503/https://tieks.com/>, Aug. 19, 2010, 1 page.

Tieks by Gavrieli—Foldable Fashionable Ballet Flats, Be a little wild . . . even when you're not., <https://web.archive.org/web/20100902020755/https://tieks.com/>, Sep. 2, 2010, 1 page.

Tieks by Gavrieli—Foldable Fashionable Ballet Flats, Obsidian Black, When workdays spill over into party nights, <https://web.archive.org/web/20100902020755/https://tieks.com/>, Sep. 2, 2010, 1 page.

Tieks by Gavrieli—Foldable Fashionable Ballet Flats, Tan Croc Print, A timeless texture, <https://web.archive.org/web/20100902020755/https://tieks.com/>, Sep. 2, 2010, 1 page.

Tieks by Gavrieli—Foldable Fashionable Ballet Flats, Paradise Blue, The perfect pair for day and night, <https://web.archive.org/web/20100902020755/https://tieks.com/>, Sep. 2, 2010, 1 page.

Tieks by Gavrieli—Foldable Fashionable Ballet Flats, Fuchsia, Sweet and sultry, <https://web.archive.org/web/20100902020755/https://tieks.com/>, Sep. 2, 2010, 1 page.

Tieks by Gavrieli—Foldable Fashionable Ballet Flats, Tiek Blue Tieks, Let yourself shine, <https://web.archive.org/web/20100902020755/https://tieks.com/>, Sep. 2, 2010, 1 page.

\* cited by examiner

*Primary Examiner* — Jonathan J Han  
(74) *Attorney, Agent, or Firm* — Morgan, Lewis & Bockius LLP

## (57) CLAIM

The ornamental design for a dual-sole shoe with stripe, color outsole patches, and contrasting upper, as shown and described.

## DESCRIPTION

The file of this patent contains at least one drawing executed in color. Copies of this patent with color drawing(s) will be provided by the Office upon request and payment of the necessary fee.

FIG. 1 is a perspective view of an embodiment of our new design of a dual-sole shoe with stripe, color outsole patches, and contrasting upper, where the portions of the upper that contrast with the purple outsole patches are indicated using a slanted line hatching pattern;

FIG. 2 is a first side view of the design of FIG. 1;

FIG. 3 is a second side view of the design of FIG. 1;

FIG. 4 is a top view of the design of FIG. 1;

FIG. 5 is a bottom view of the design of FIG. 1;

FIG. 6 is a front view of the design of FIG. 1;

FIG. 7 is a back view of the design of FIG. 1;

FIG. 8 is a perspective view of another embodiment of our new design of a dual-sole shoe with stripe, color outsole



patches, and contrasting upper, where the color portions are indicated using the USPTO convention of dashed vertical lines for violet or purple, and where the portions of the upper that contrast with the outsole patches are indicated using a slanted line hatching pattern;

FIG. 9 is a first side view of the design of FIG. 8;  
FIG. 10 is a second side view of the design of FIG. 8;  
FIG. 11 is a top view of the design of FIG. 8;  
FIG. 12 is a bottom view of the design of FIG. 8;  
FIG. 13 is a front view of the design of FIG. 8;  
FIG. 14 is a back view of the design of FIG. 8;  
FIG. 15 is a perspective view of yet another embodiment of our new design of a dual-sole shoe with stripe, color outsole patches, and contrasting upper, where the portions of the upper that contrast with the green outsole patches are indicated using a slanted line hatching pattern;  
FIG. 16 is a first side view of the design of FIG. 15;  
FIG. 17 is a second side view of the design of FIG. 15;  
FIG. 18 is a top view of the design of FIG. 15;  
FIG. 19 is a bottom view of the design of FIG. 15;  
FIG. 20 is a front view of the design of FIG. 15;  
FIG. 21 is a back view of the design of FIG. 15;  
FIG. 22 is a perspective view of yet another embodiment of our new design of a dual-sole shoe with stripe, color outsole patches, and contrasting upper, where the color portions are indicated using the USPTO convention of solid diagonal lines extending from the upper left to the lower right for green, and where the portions of the upper that contrast with the outsole patches are indicated using a crosshatch pattern;  
FIG. 23 is a first side view of the design of FIG. 22;  
FIG. 24 is a second side view of the design of FIG. 22;  
FIG. 25 is a top view of the design of FIG. 22;  
FIG. 26 is a bottom view of the design of FIG. 22;  
FIG. 27 is a front view of the design of FIG. 22;  
FIG. 28 is a back view of the design of FIG. 22;  
FIG. 29 is a perspective view of yet another embodiment of our new design of a dual-sole shoe with stripe, color outsole patches, and contrasting upper, where the portions of the upper that contrast with the red outsole patches are indicated using a slanted line hatching pattern;  
FIG. 30 is a first side view of the design of FIG. 29;  
FIG. 31 is a second side view of the design of FIG. 29;  
FIG. 32 is a top view of the design of FIG. 29;  
FIG. 33 is a bottom view of the design of FIG. 29;  
FIG. 34 is a front view of the design of FIG. 29;  
FIG. 35 is a back view of the design of FIG. 29;  
FIG. 36 is a perspective view of yet another embodiment of our new design of a dual-sole shoe with stripe, color outsole patches, and contrasting upper, where the color portions are indicated using the USPTO convention of solid vertical lines for red or pink, and where the portions of the upper that contrast with the outsoles patches are indicated using a slanted line hatching pattern;  
FIG. 37 is a first side view of the design of FIG. 36;  
FIG. 38 is a second side view of the design of FIG. 36;  
FIG. 39 is a top view of the design of FIG. 36;  
FIG. 40 is a bottom view of the design of FIG. 36;  
FIG. 41 is a front view of the design of FIG. 36;  
FIG. 42 is a back view of the design of FIG. 36;  
FIG. 43 is a perspective view of yet another embodiment of our new design of a dual-sole shoe with stripe, color outsole patches, and contrasting upper, where the portions of the upper that contrast with the blue outsole patches are indicated using a slanted line hatching pattern;  
FIG. 44 is a first side view of the design of FIG. 43;

FIG. 45 is a second side view of the design of FIG. 43;  
FIG. 46 is a top view of the design of FIG. 43;  
FIG. 47 is a bottom view of the design of FIG. 43;  
FIG. 48 is a front view of the design of FIG. 43;  
FIG. 49 is a back view of the design of FIG. 43;  
FIG. 50 is a perspective view of yet another embodiment of our new design of a dual-sole shoe with stripe, color outsole patches, and contrasting upper, where the color portions are indicated using the USPTO convention of horizontal lines for blue, and where the portions of the upper that contrast with the outsole patches are indicated using a slanted line hatching pattern;  
FIG. 51 is a first side view of the design of FIG. 50;  
FIG. 52 is a second side view of the design of FIG. 50;  
FIG. 53 is a top view of the design of FIG. 50;  
FIG. 54 is a bottom view of the design of FIG. 50;  
FIG. 55 is a front view of the design of FIG. 50;  
FIG. 56 is a back view of the design of FIG. 50;  
FIG. 57 is a perspective view of yet another embodiment of our new design of a dual-sole shoe with stripe, color outsole patches, and contrasting upper, where the color portions are indicated using a cross-hatched pattern to indicate the blue color Pantone 7466C, and where the portions of the upper that contrast with the outsole patches are indicated using a slanted line hatching pattern;  
FIG. 58 is a first side view of the design of FIG. 57;  
FIG. 59 is a second side view of the design of FIG. 57;  
FIG. 60 is a top view of the design of FIG. 57;  
FIG. 61 is a bottom view of the design of FIG. 57;  
FIG. 62 is a front view of the design of FIG. 57;  
FIG. 63 is a back view of the design of FIG. 57;  
FIG. 64 is a perspective view of yet another embodiment of our new design of a dual-sole shoe with stripe, color outsole patches, and contrasting upper, where the portions of the upper that contrast with the orange outsoles patches are indicated using a slanted line hatching pattern;  
FIG. 65 is a first side view of the design of FIG. 64;  
FIG. 66 is a second side view of the design of FIG. 64;  
FIG. 67 is a top view of the design of FIG. 64;  
FIG. 68 is a bottom view of the design of FIG. 64;  
FIG. 69 is a front view of the design of FIG. 64;  
FIG. 70 is a back view of the design of FIG. 64;  
FIG. 71 is a perspective view of yet another embodiment of our new design of a dual-sole shoe with stripe, color outsole patches, and contrasting upper, where the color portions are indicated using the USPTO convention of diagonal cross-hatched lines for orange, and where the portions of the upper that contrast with the outsole patches are indicated using a slanted line hatching pattern;  
FIG. 72 is a first side view of the design of FIG. 71;  
FIG. 73 is a second side view of the design of FIG. 71;  
FIG. 74 is a top view of the design of FIG. 71;  
FIG. 75 is a bottom view of the design of FIG. 71;  
FIG. 76 is a front view of the design of FIG. 71;  
FIG. 77 is a back view of the design of FIG. 71;  
FIG. 78 is a perspective view of yet another embodiment of our new design of a dual-sole shoe with stripe, color outsole patches, and contrasting upper, where the portions of the upper that contrast with the yellow outsole patches are indicated using a slanted line hatching pattern;  
FIG. 79 is a first side view of the design of FIG. 78;  
FIG. 80 is a second side view of the design of FIG. 78;  
FIG. 81 is a top view of the design of FIG. 78;  
FIG. 82 is a bottom view of the design of FIG. 78;  
FIG. 83 is a front view of the design of FIG. 78;

FIG. 84 is a back view of the design of FIG. 78;  
FIG. 85 is a perspective view of yet another embodiment of our new design of a dual-sole shoe with stripe, color outsole patches, and contrasting upper, where the color portions are indicated using the USPTO convention of vertical and horizontal cross-hatched lines for yellow or gold, and where the portions of the upper that contrast with the outsole patches are indicated using a slanted line hatching pattern;  
FIG. 86 is a first side view of the design of FIG. 85;  
FIG. 87 is a second side view of the design of FIG. 85;  
FIG. 88 is a top view of the design of FIG. 85;  
FIG. 89 is a bottom view of the design of FIG. 85;  
FIG. 90 is a front view of the design of FIG. 85;  
FIG. 91 is a back view of the design of FIGS. 85; and  
FIG. 92 is a perspective view of yet another embodiment of our new design of a dual-sole shoe with stripe, color outsole patches, and contrasting upper, where the portions of the upper that contrast with the outsole patches are indicated using a slanted line hatching pattern;  
FIG. 93 is a first side view of the design of FIG. 92;  
FIG. 94 is a second side view of the design of FIG. 92;  
FIG. 95 is a top view of the design of FIG. 92;  
FIG. 96 is a bottom view of the design of FIG. 92;  
FIG. 97 is a front view of the design of FIG. 92; and,  
FIG. 98 is a back view of the design of FIG. 92.  
The broken lines illustrating the half moon patch and the groove in the above described Figures are understood to be unclaimed subject matter.

**1 Claim, 84 Drawing Sheets**  
**(30 of 84 Drawing Sheet(s) Filed in Color)**



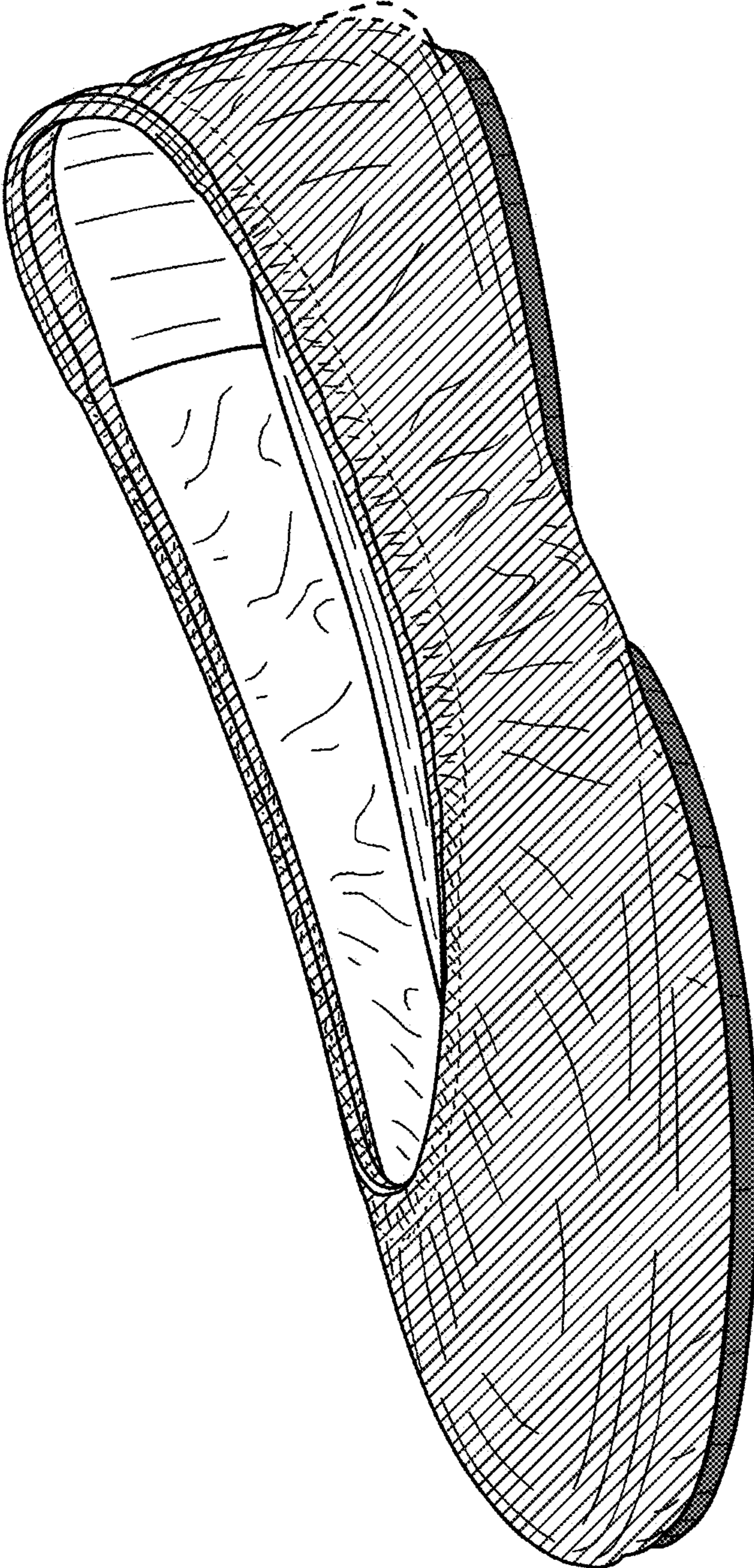

FIG. 1



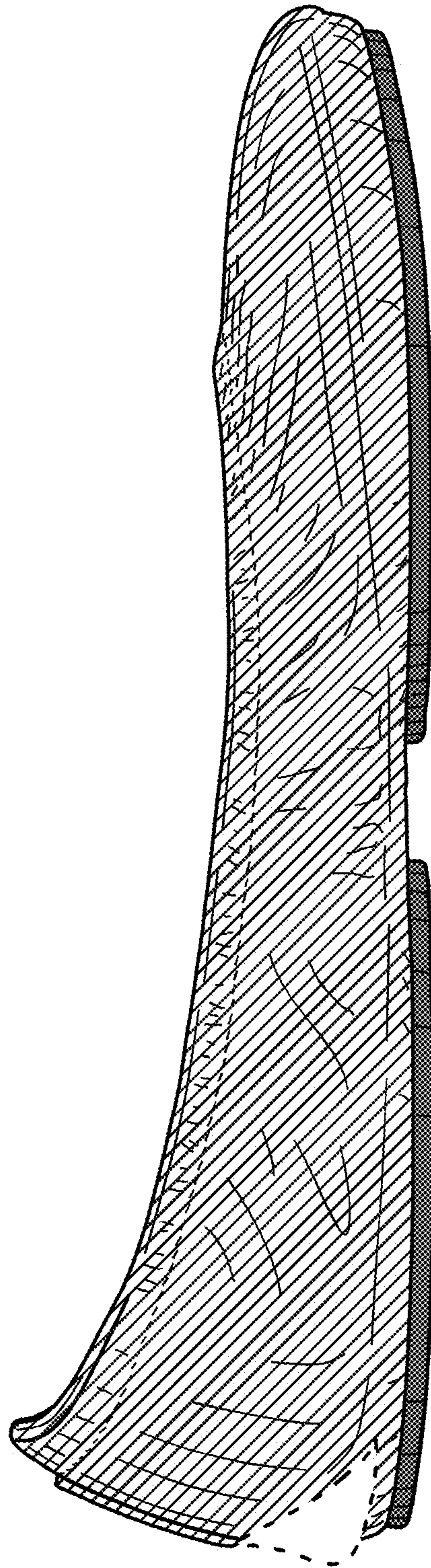

FIG. 2



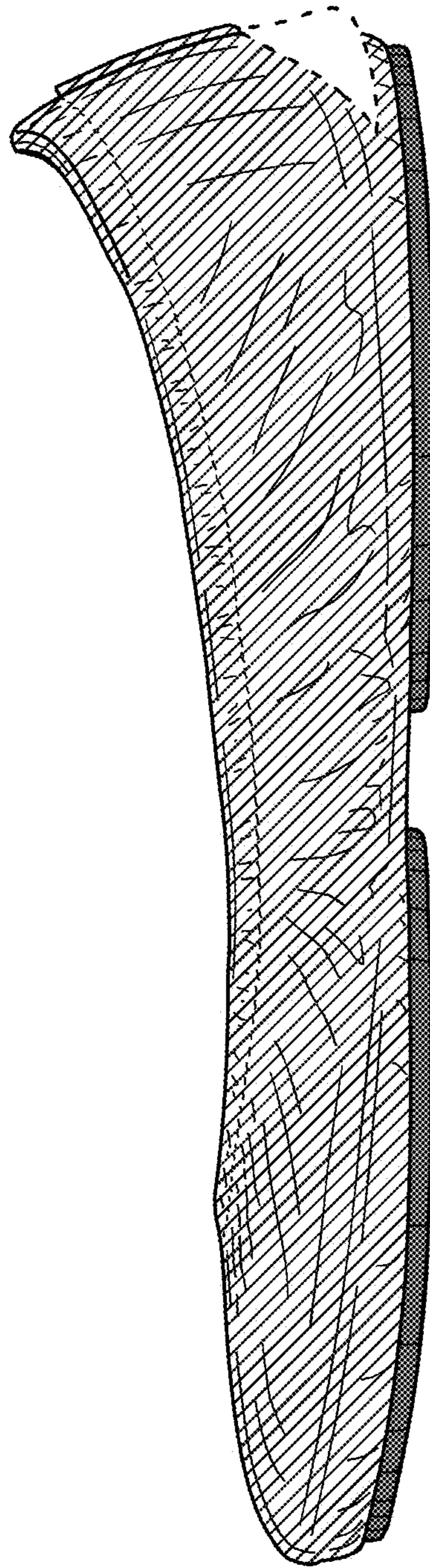

FIG. 3



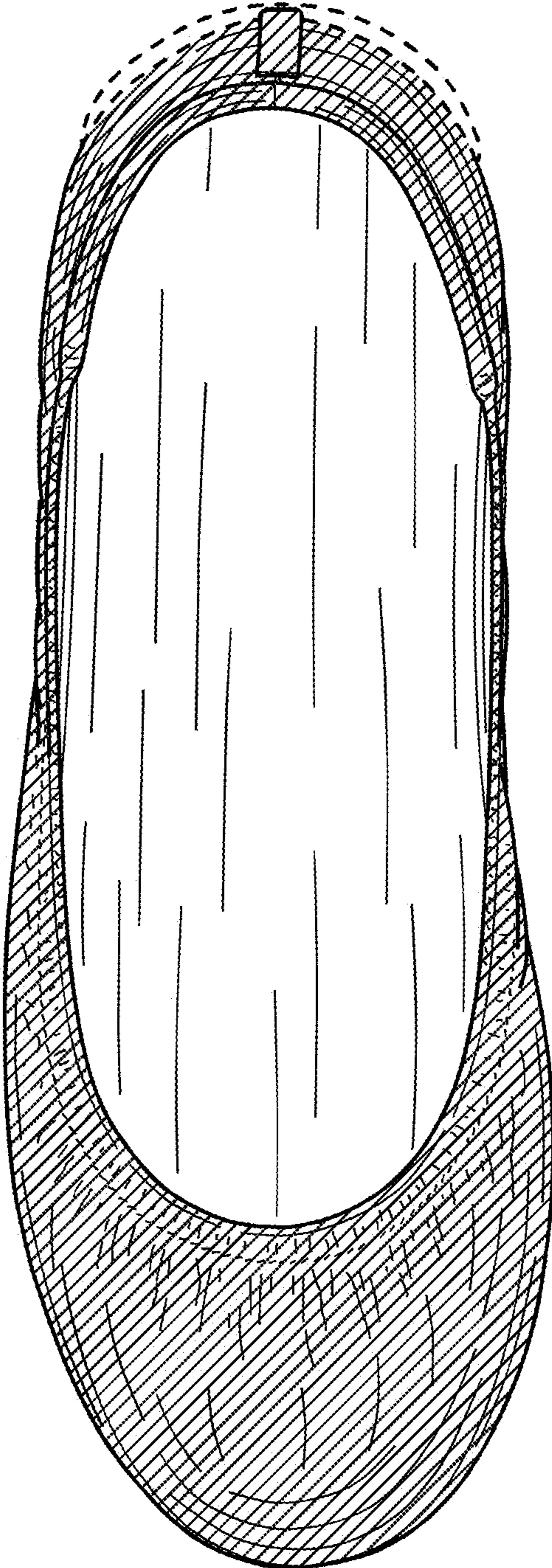

FIG. 4



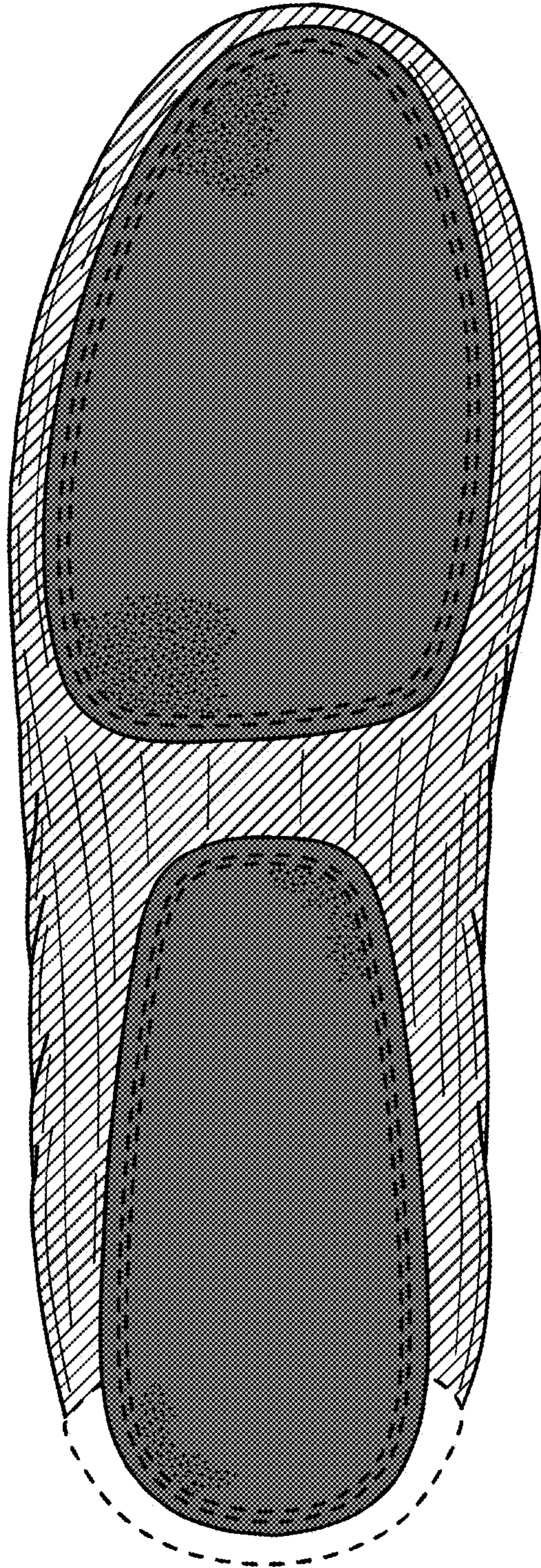

FIG. 5



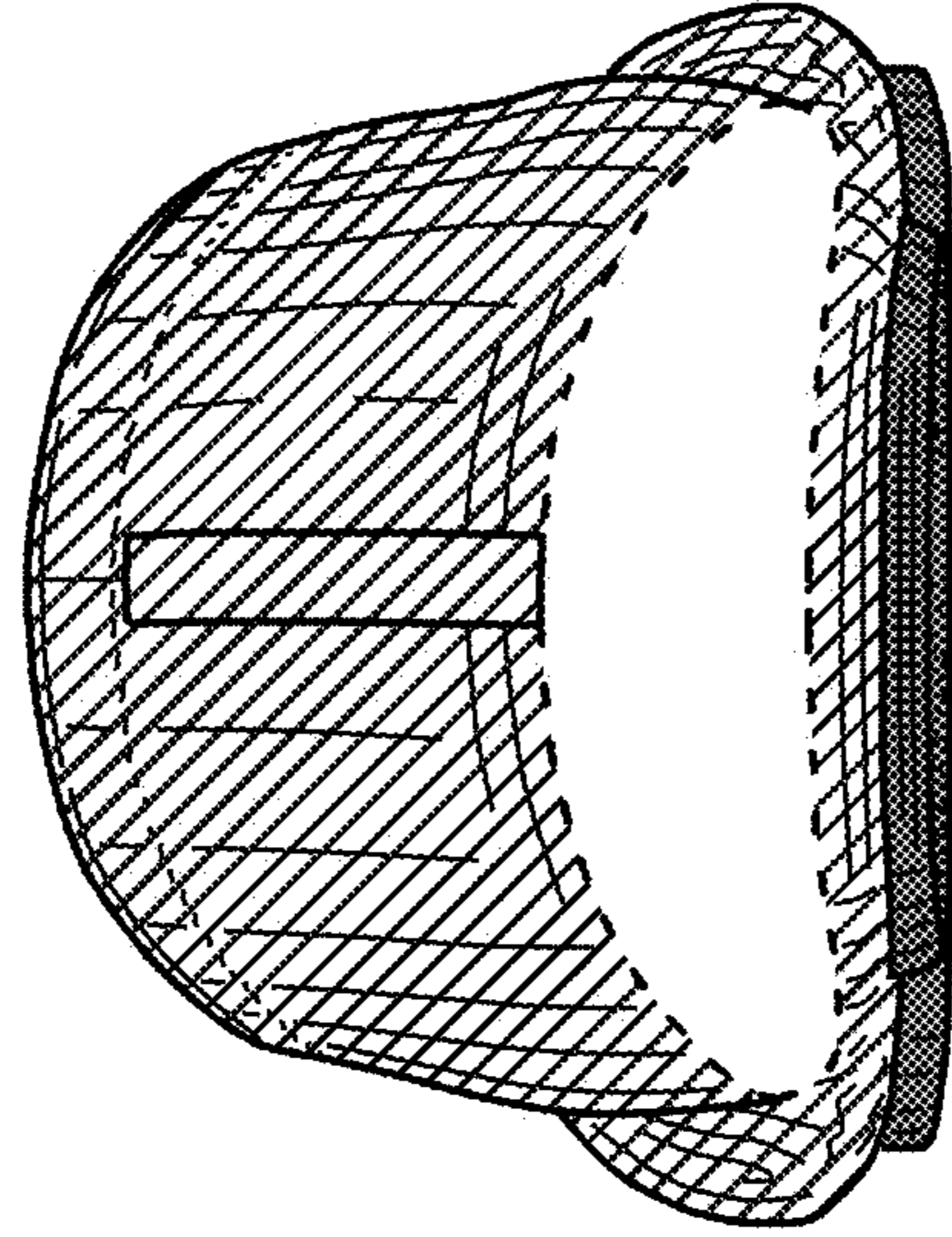

FIG. 7

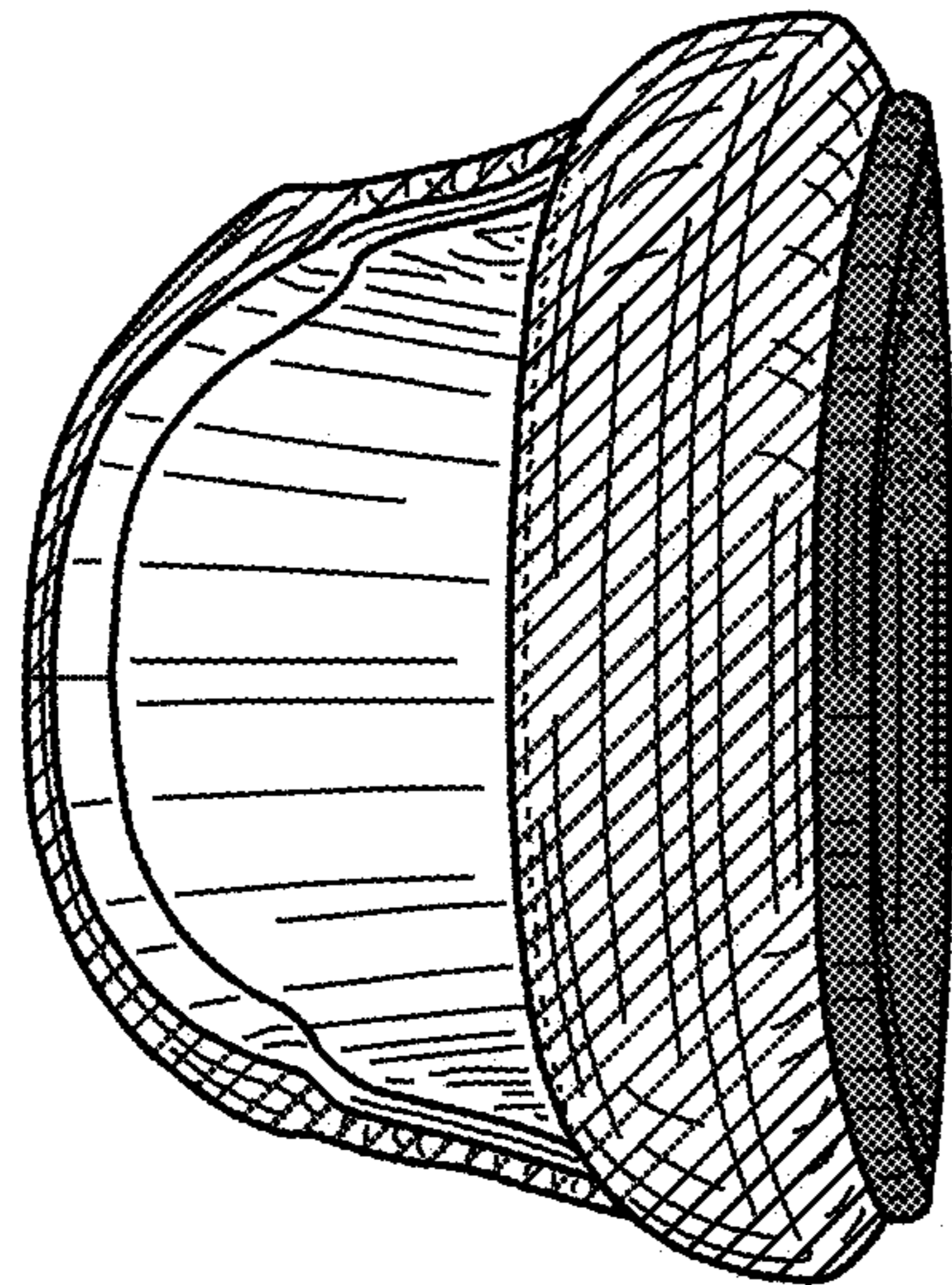

FIG. 6



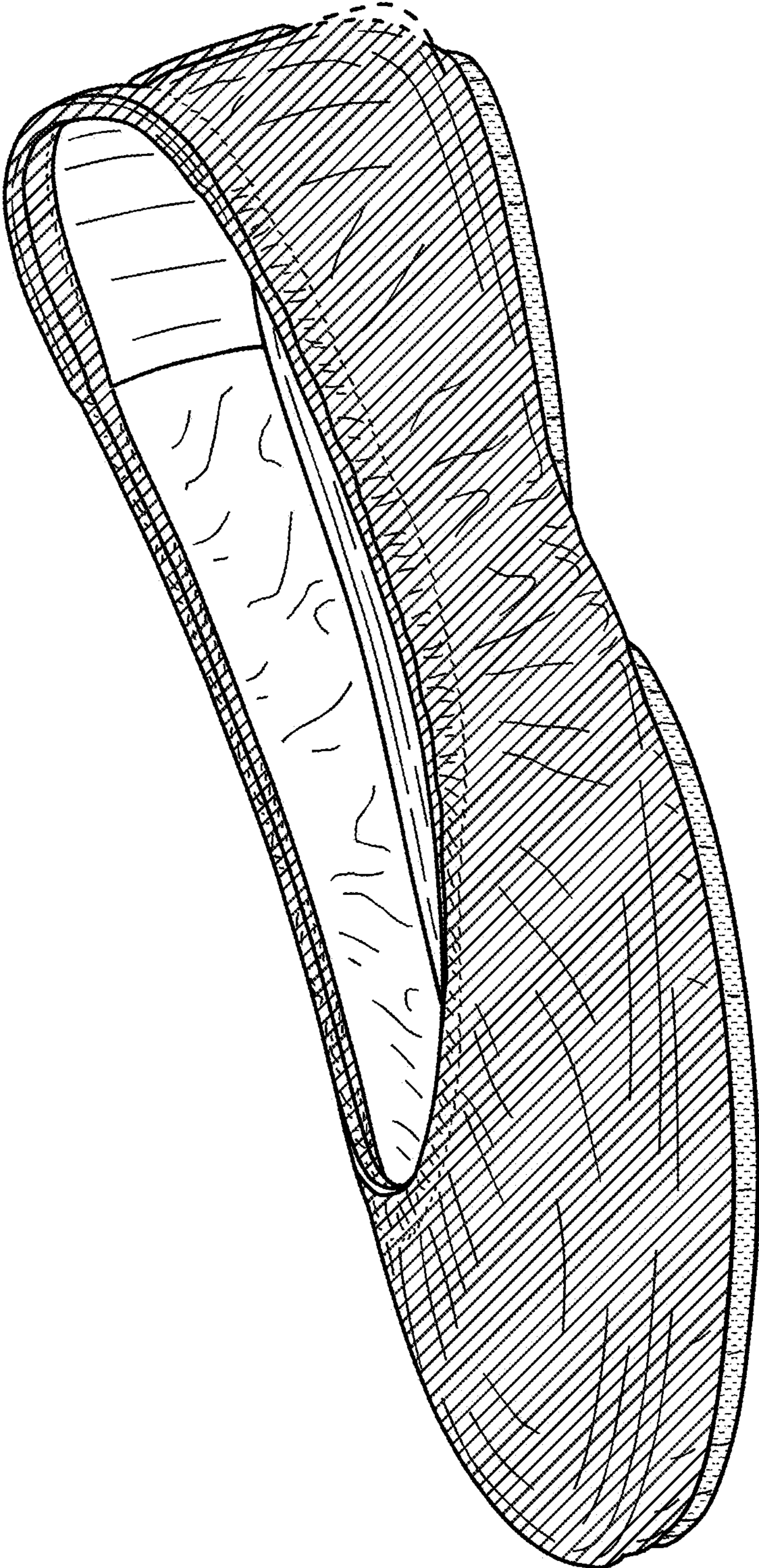

FIG. 8



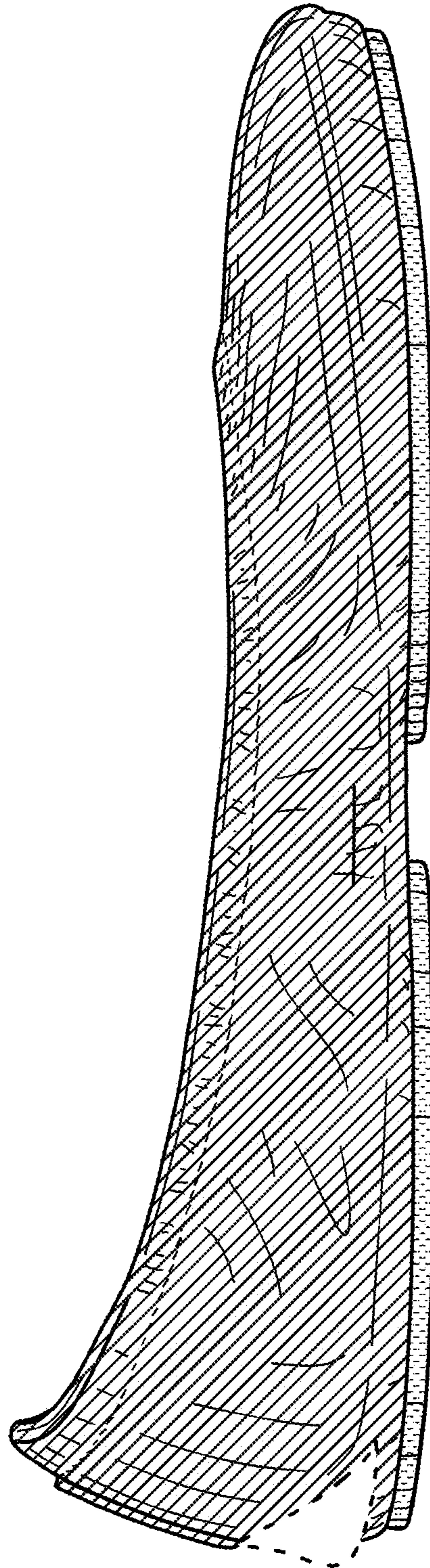

FIG. 9



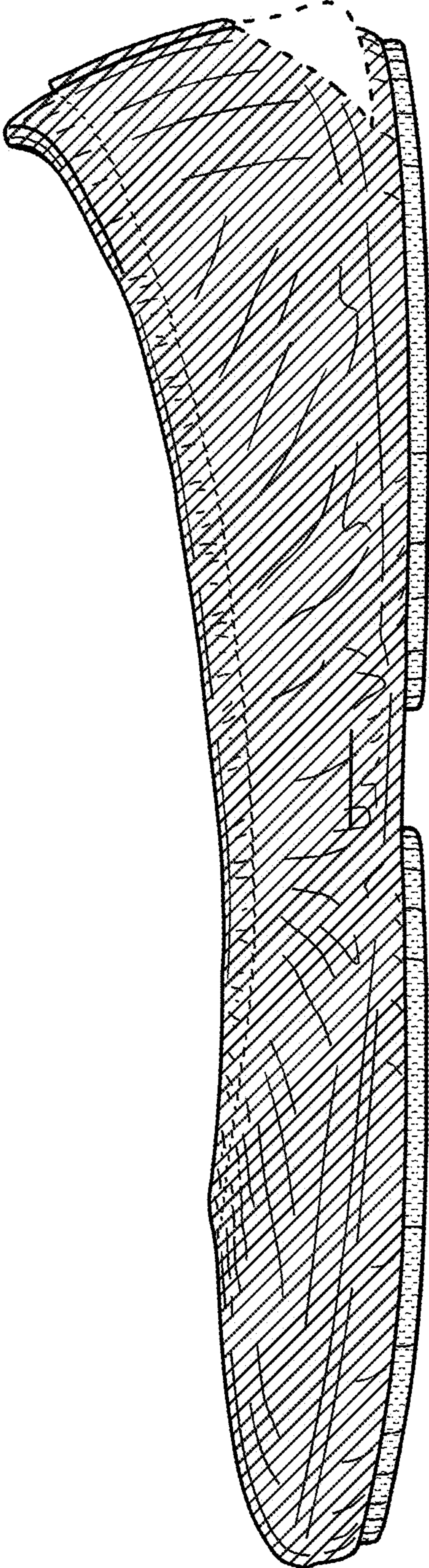

FIG. 10



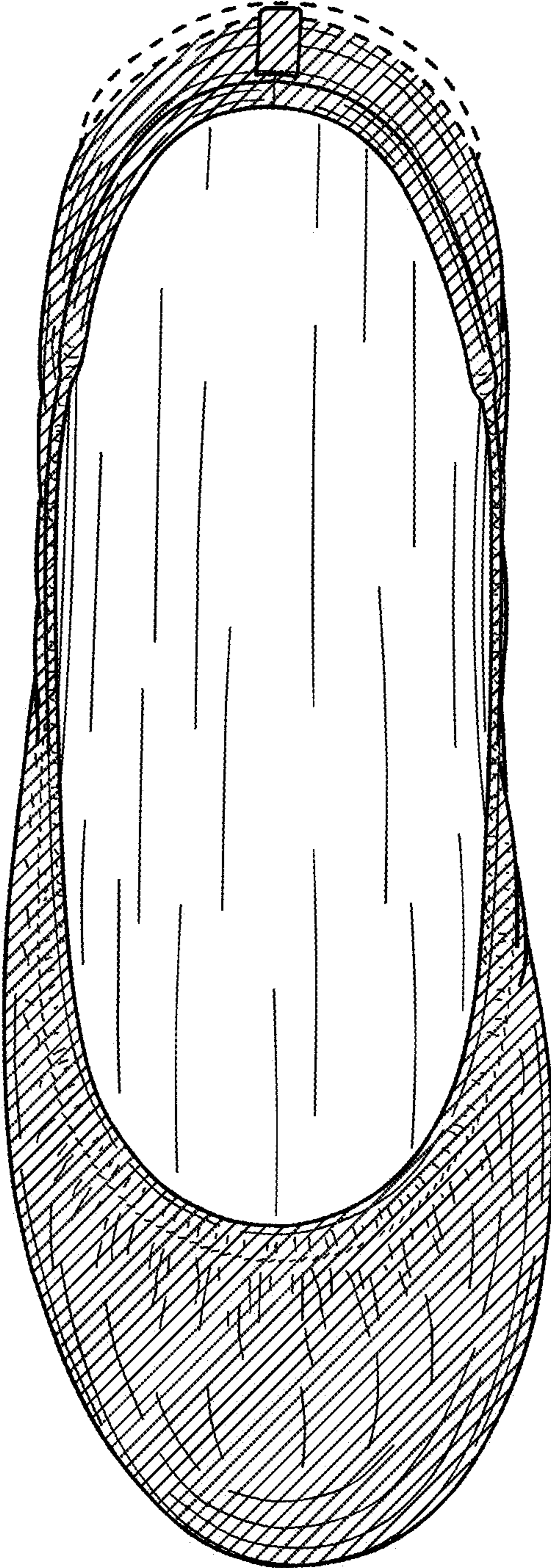

FIG. 11



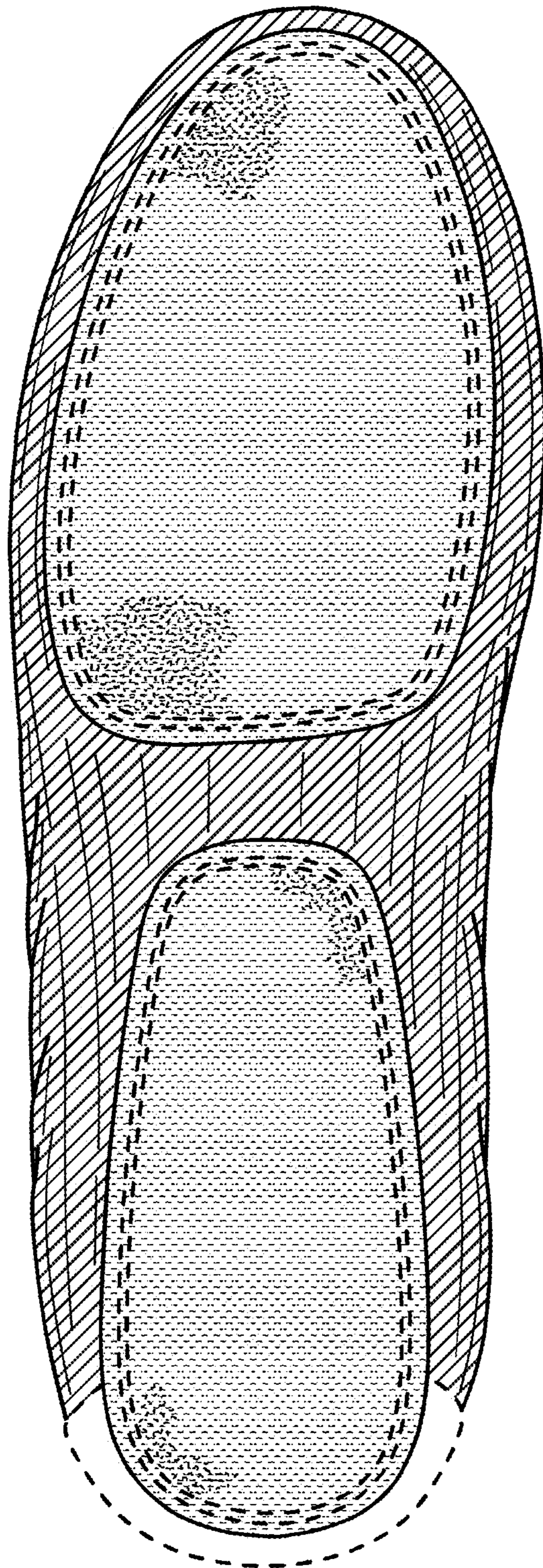

FIG. 12



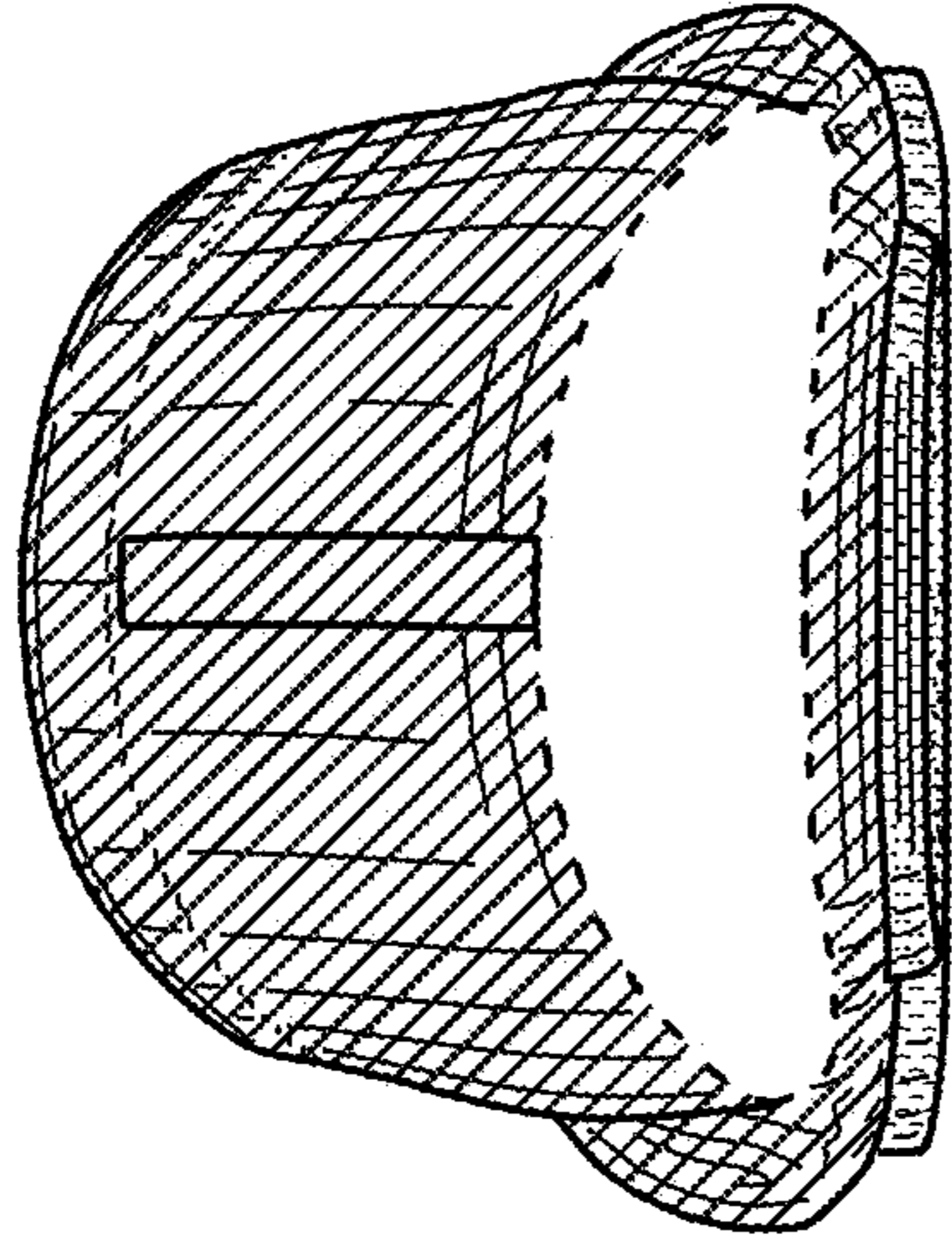

FIG. 14

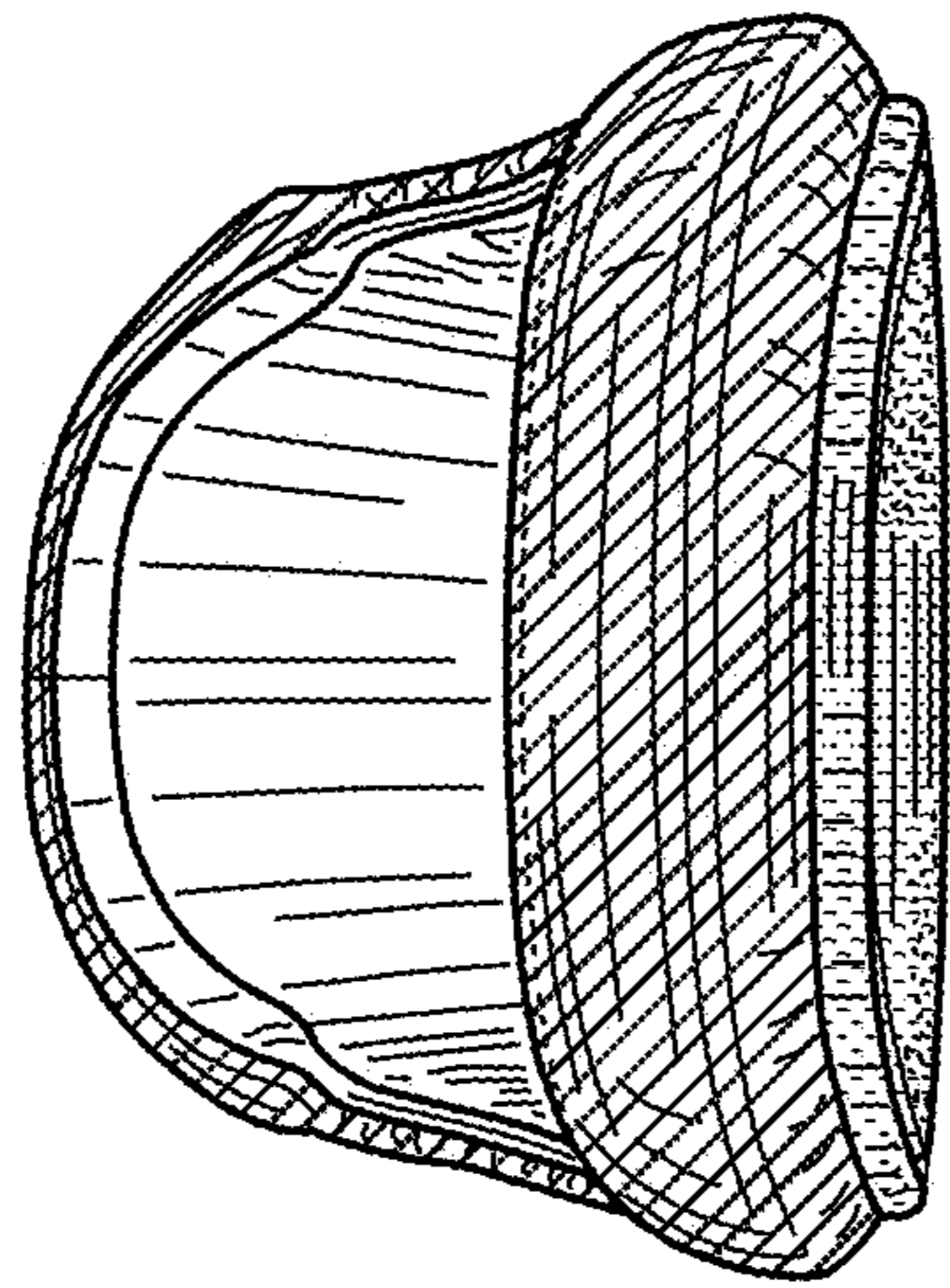

FIG. 13

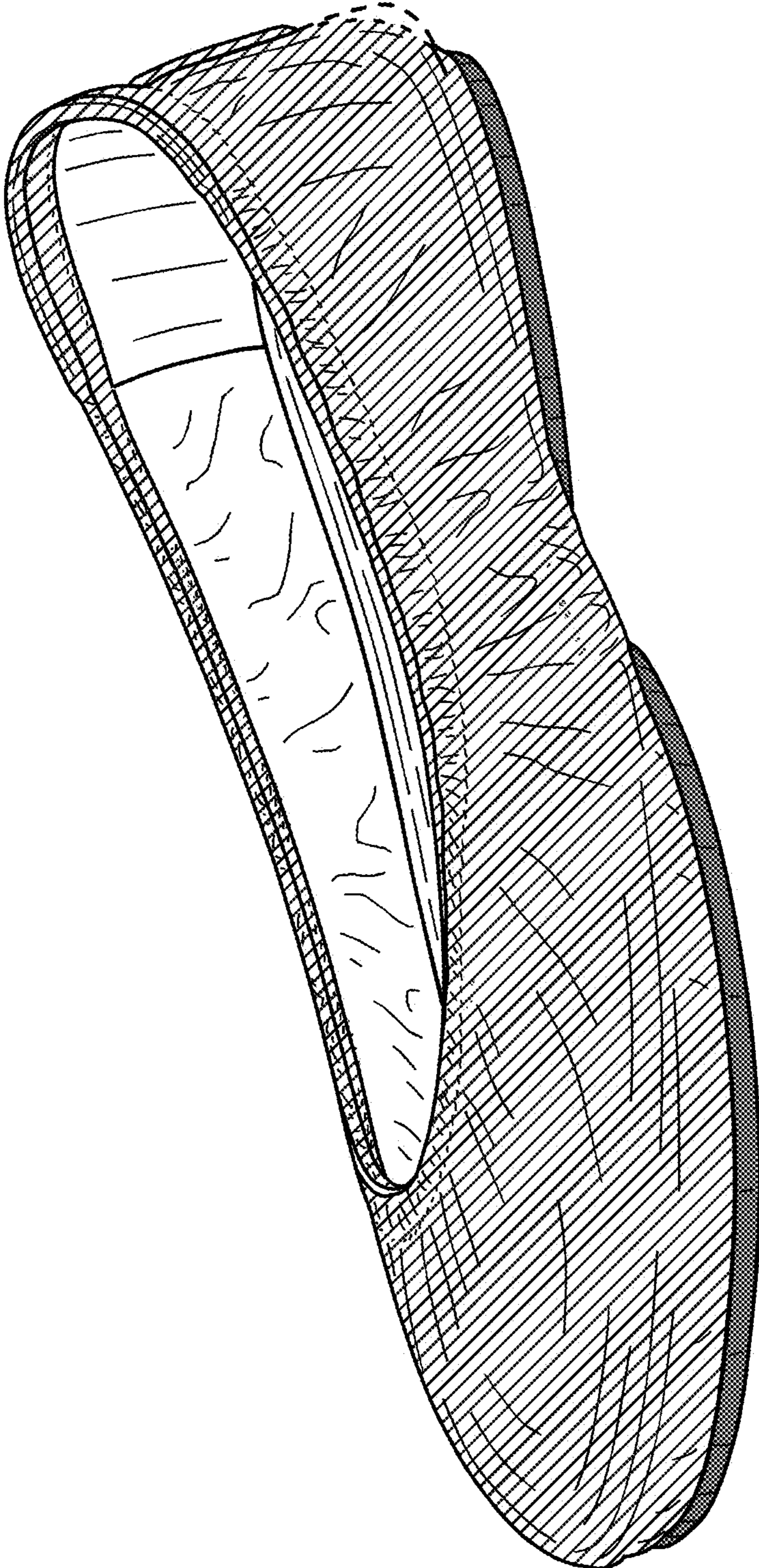

FIG. 15



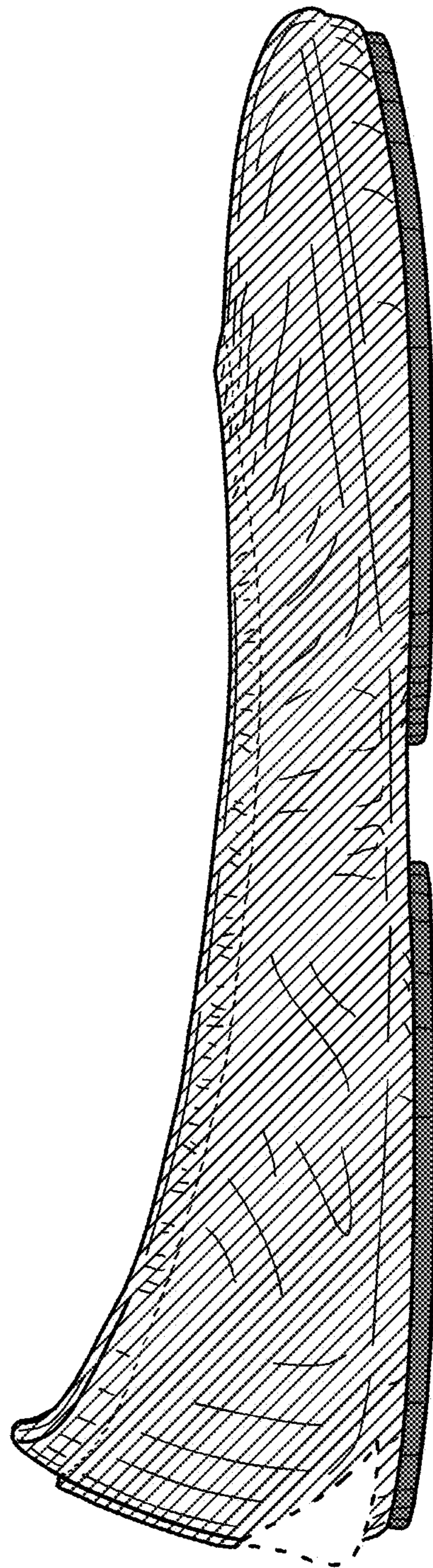

FIG. 16

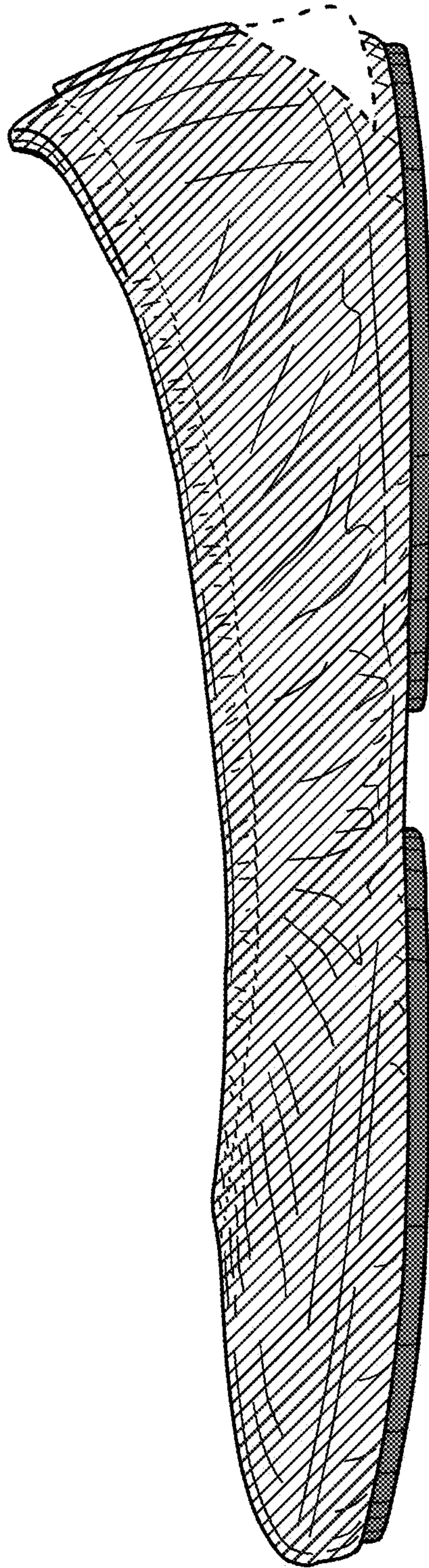

FIG. 17



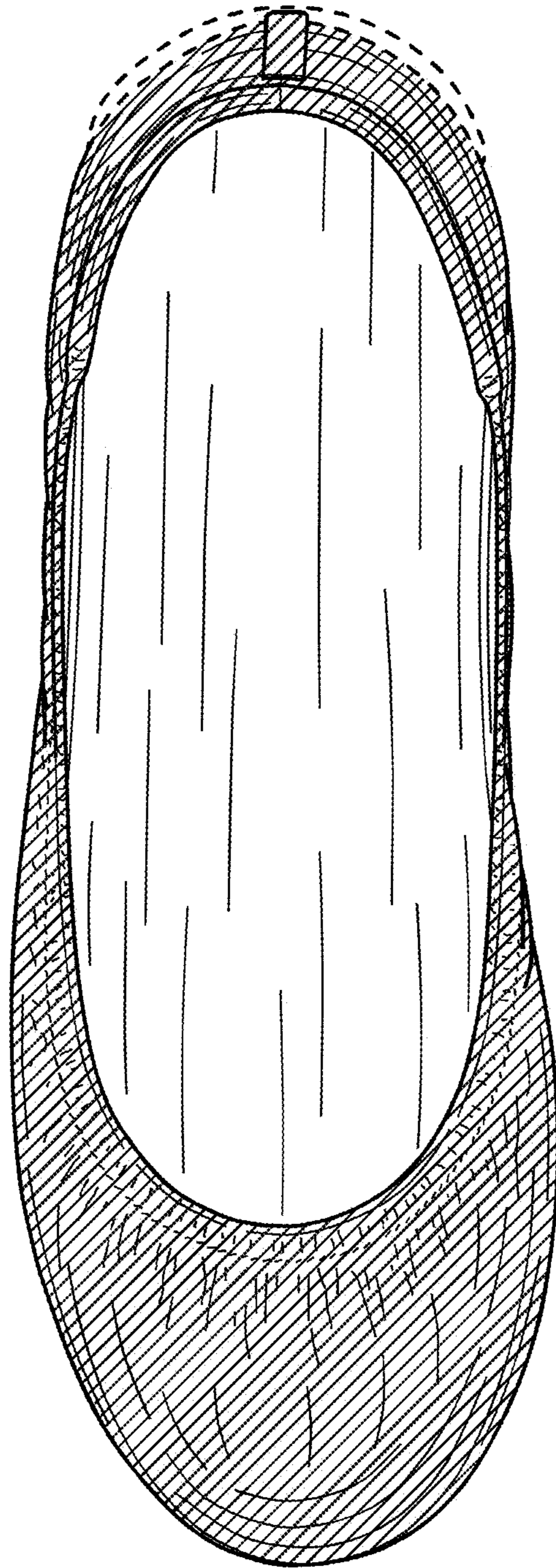

FIG. 18



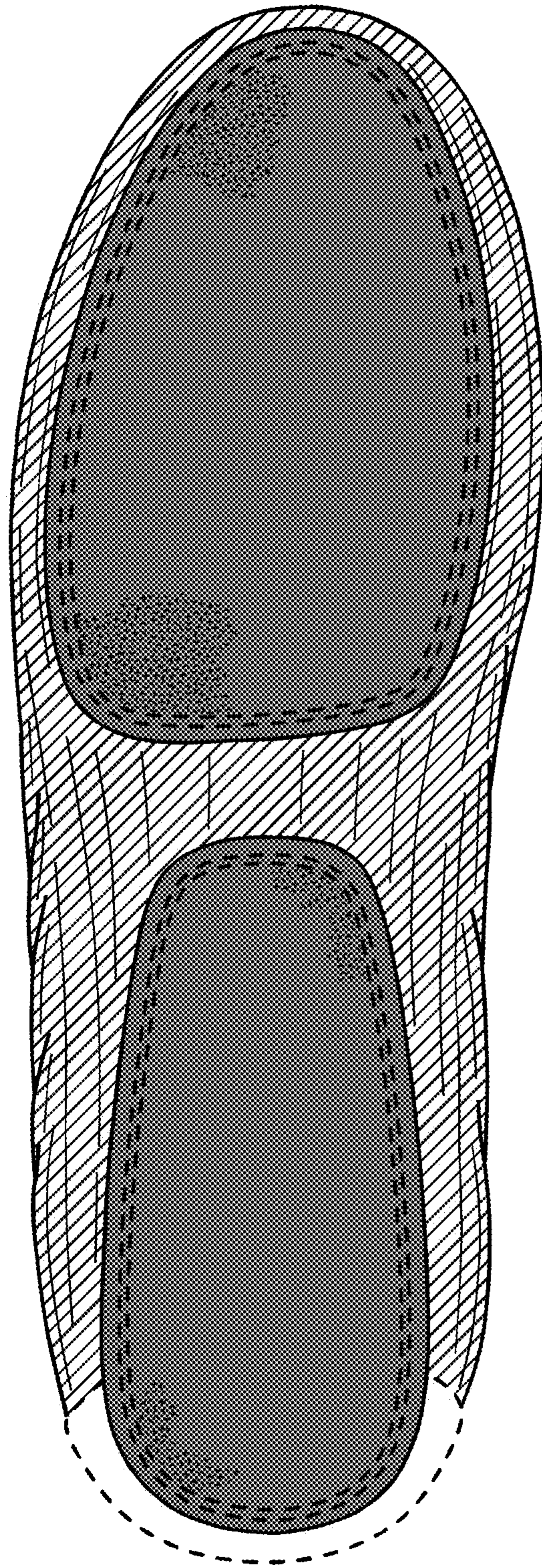

FIG. 19



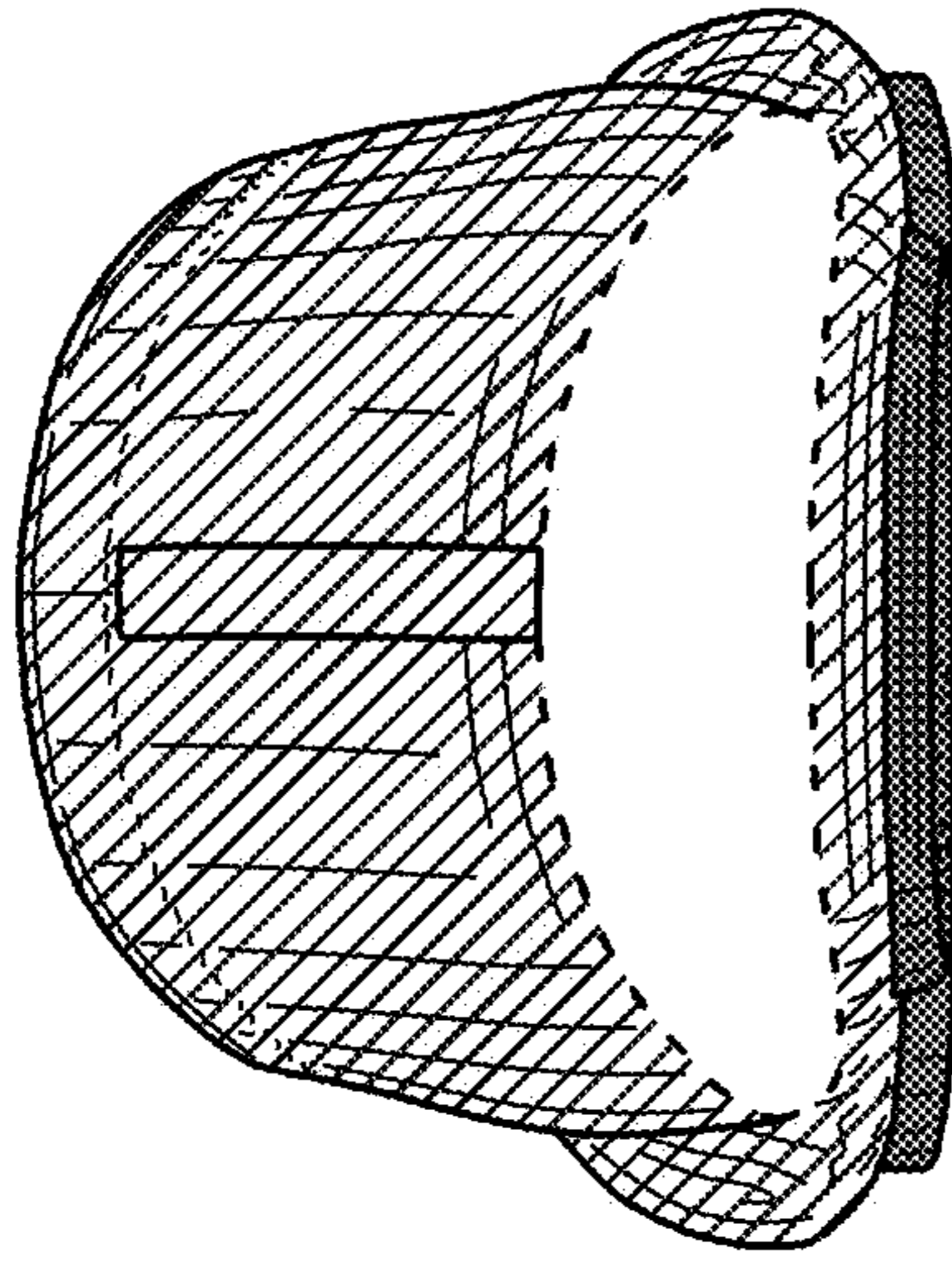

FIG. 21

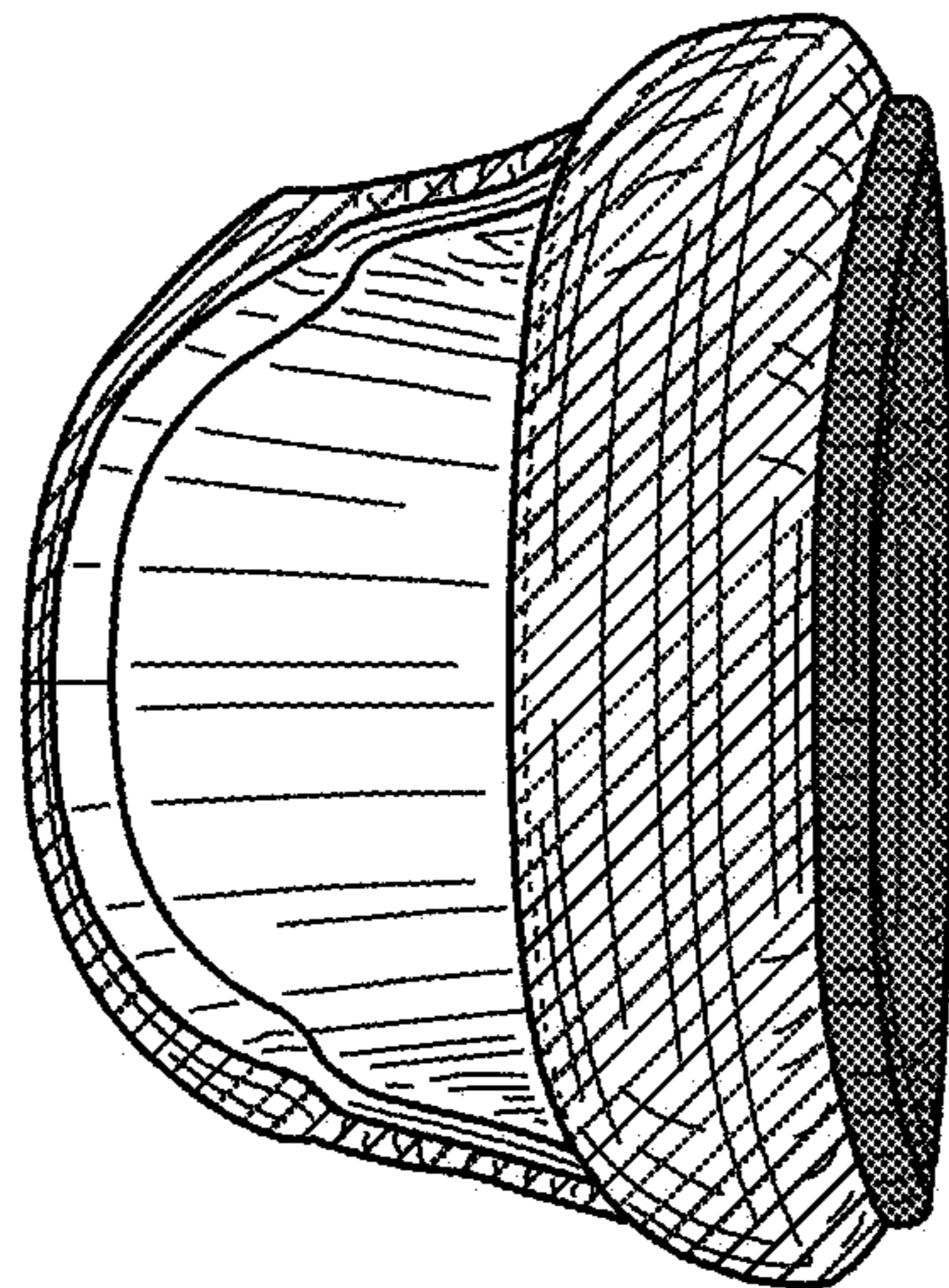

FIG. 20

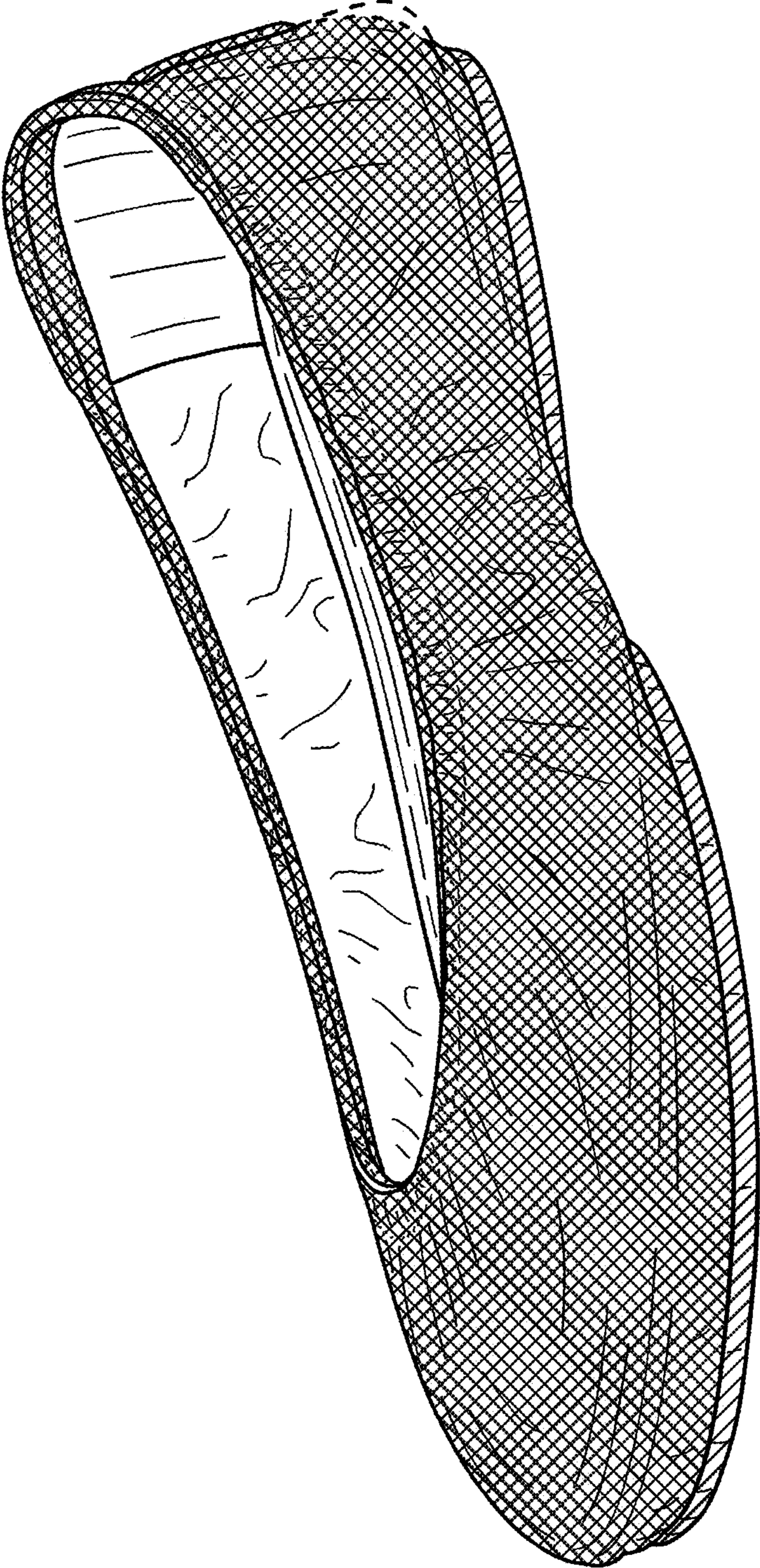

FIG. 22



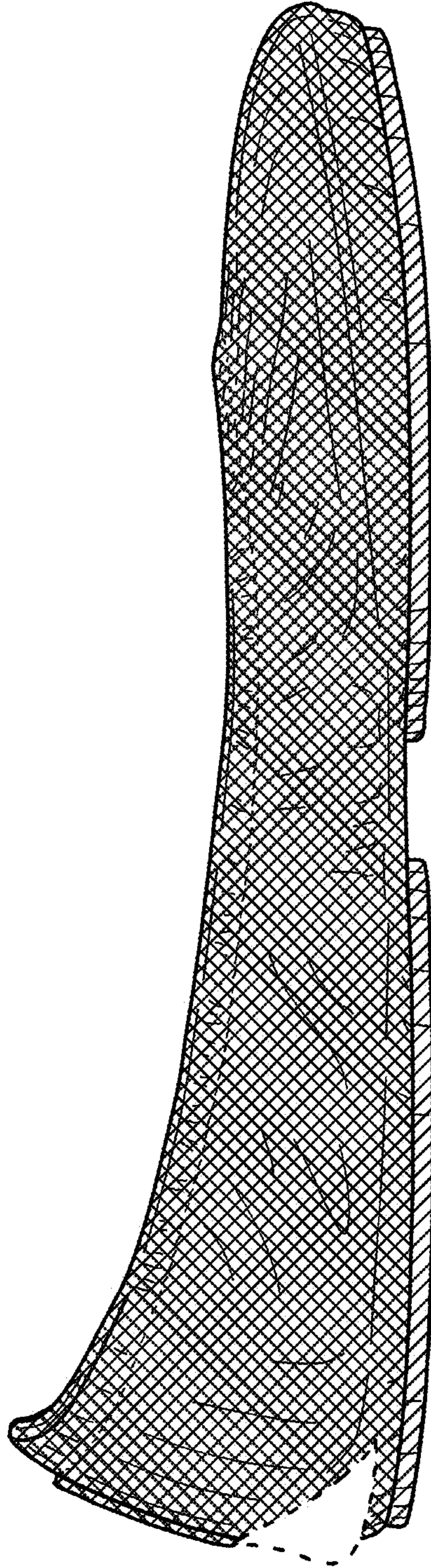

FIG. 23

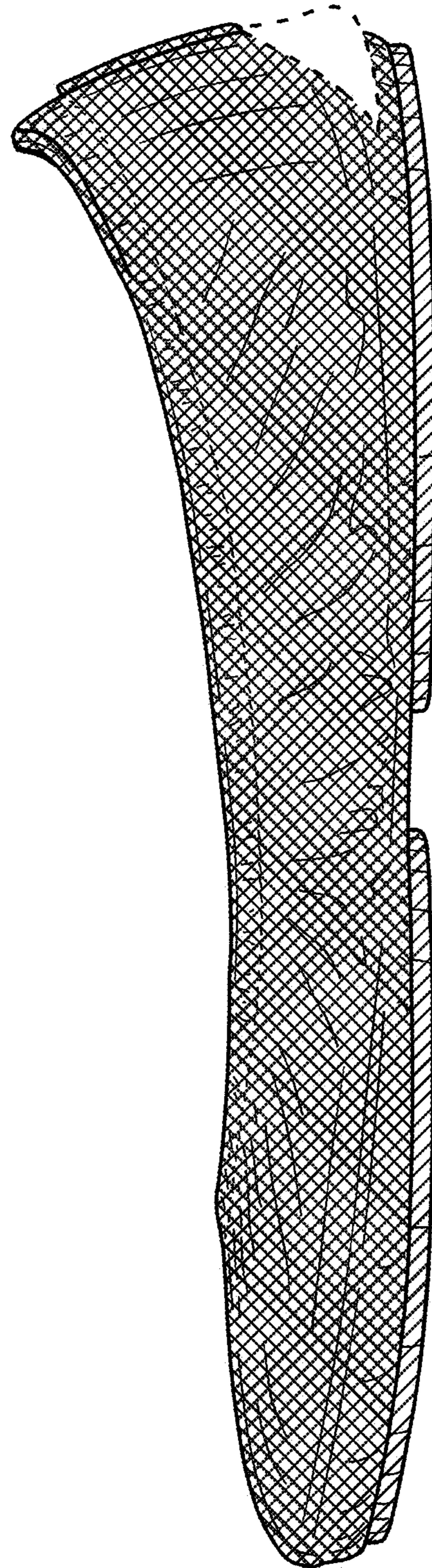

FIG. 24



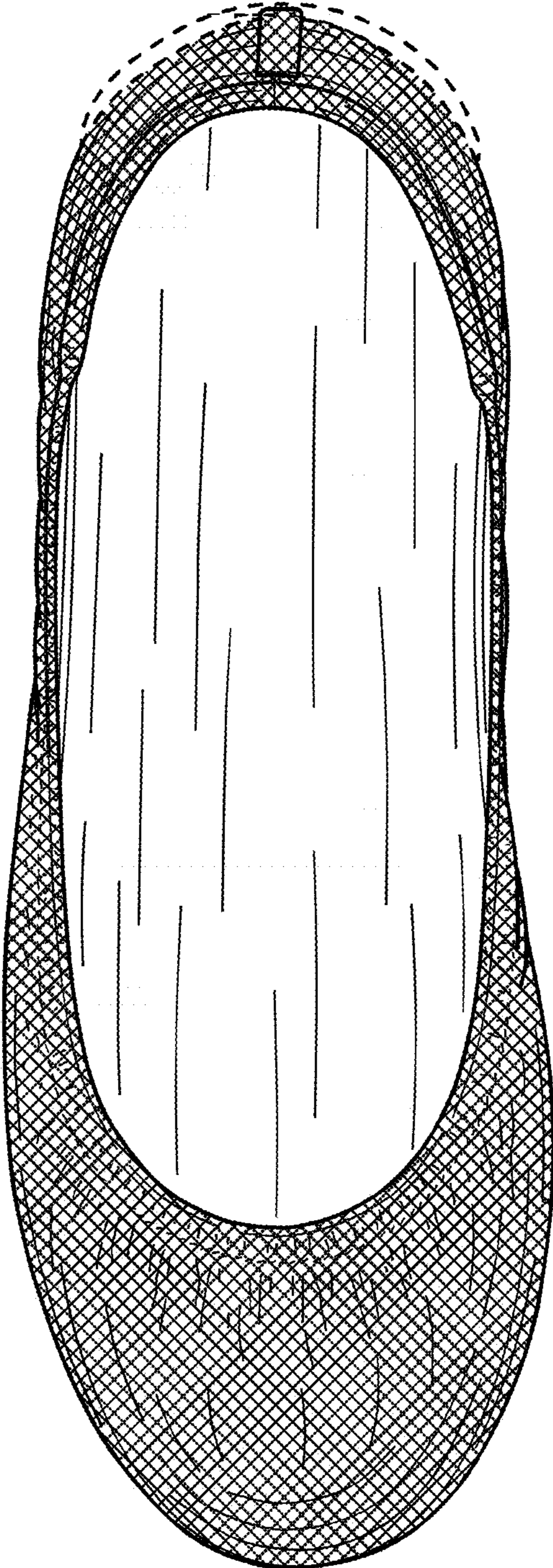

FIG. 25

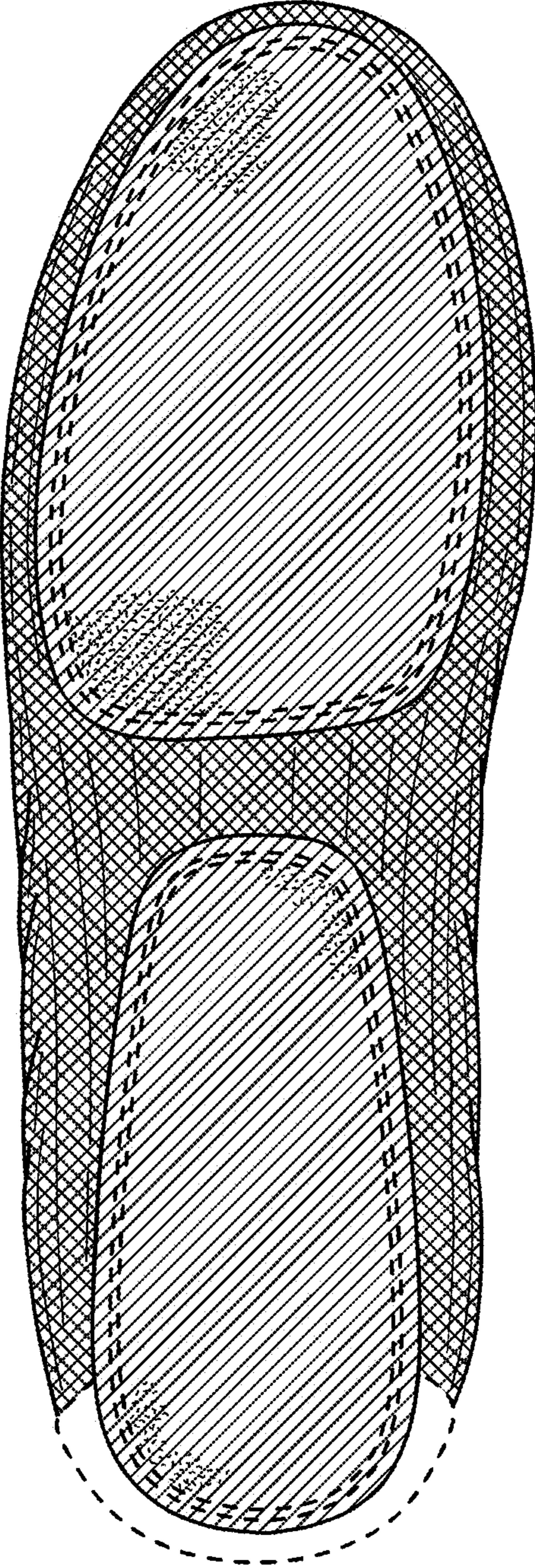

FIG. 26



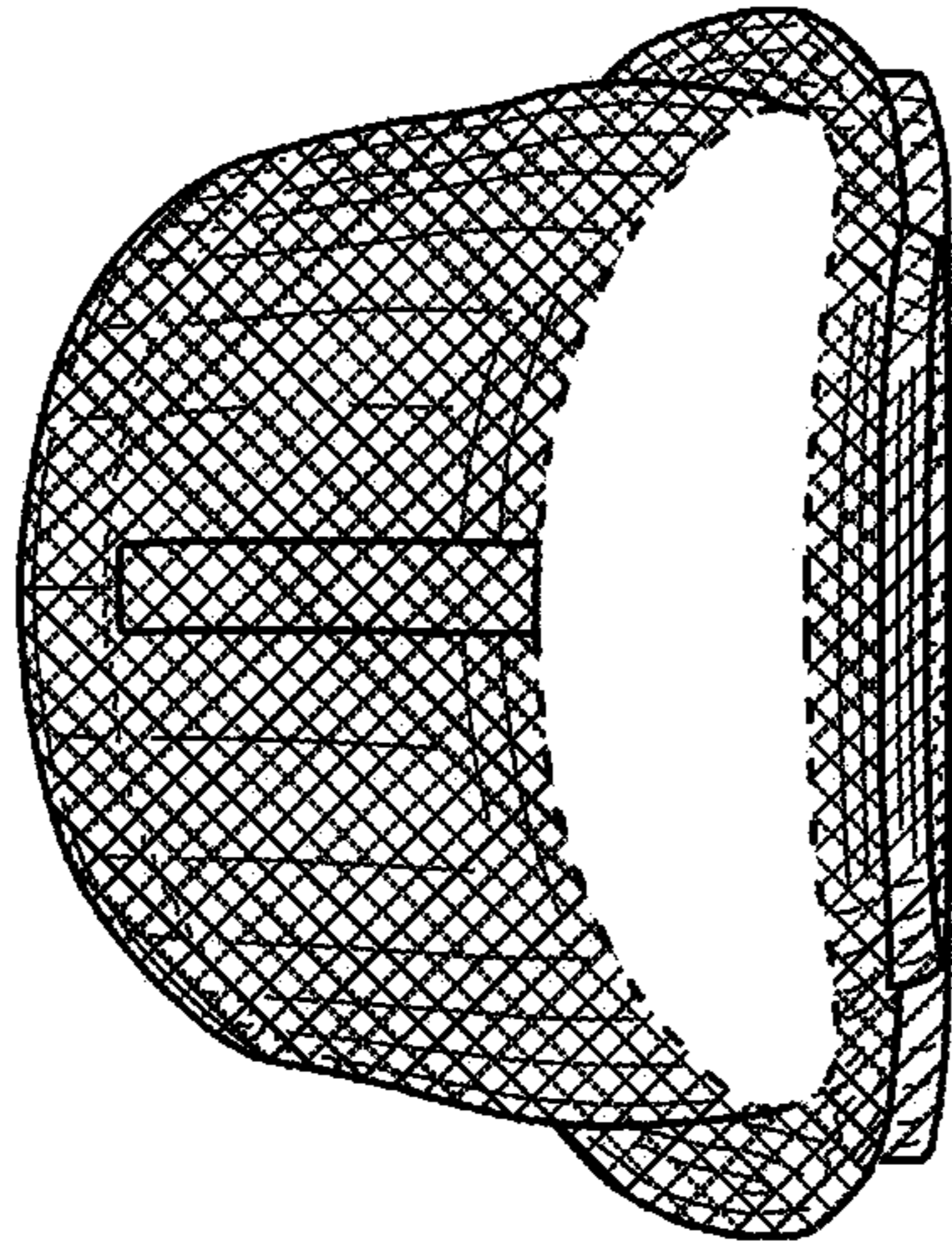

FIG. 27

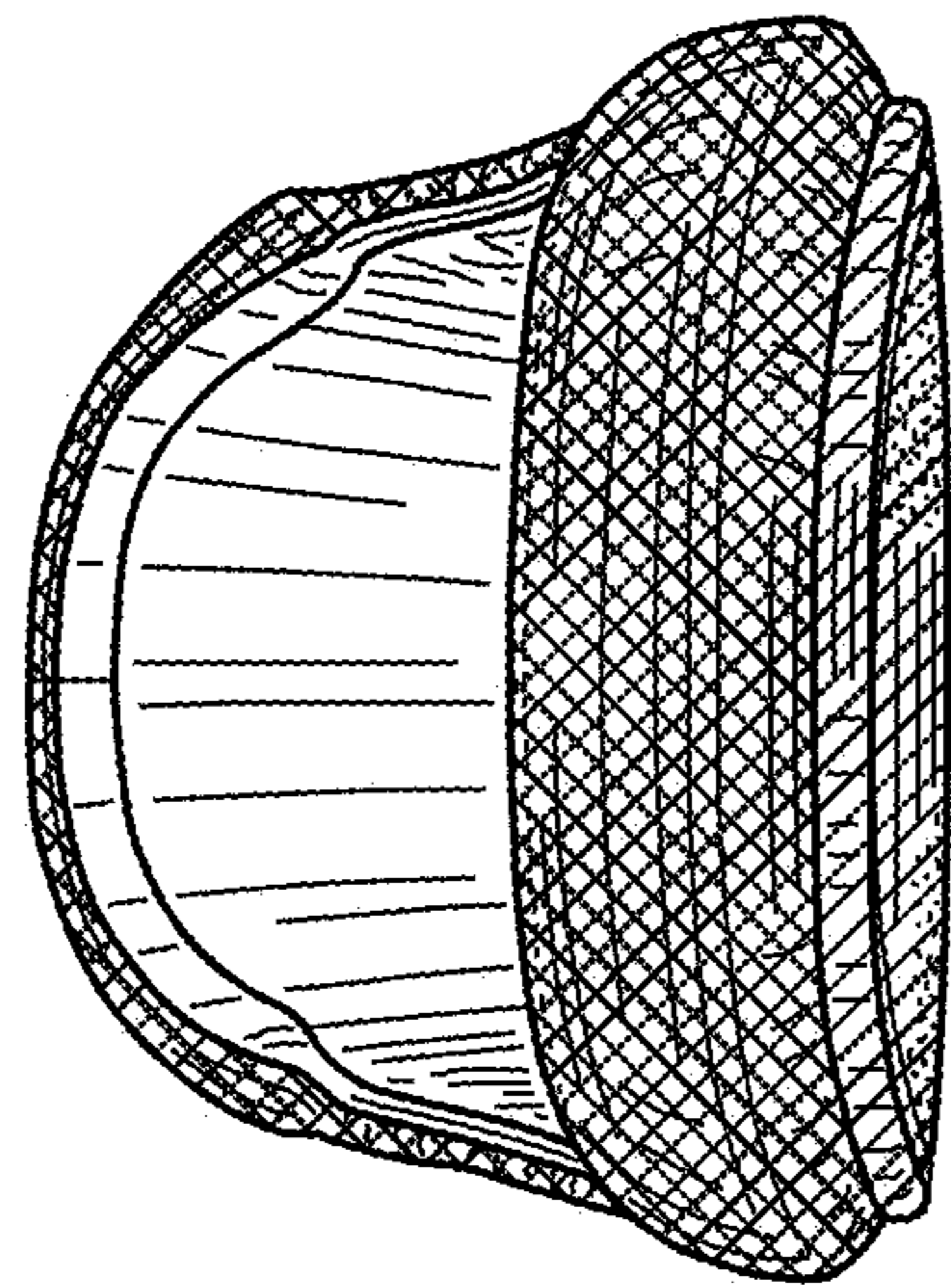

FIG. 28

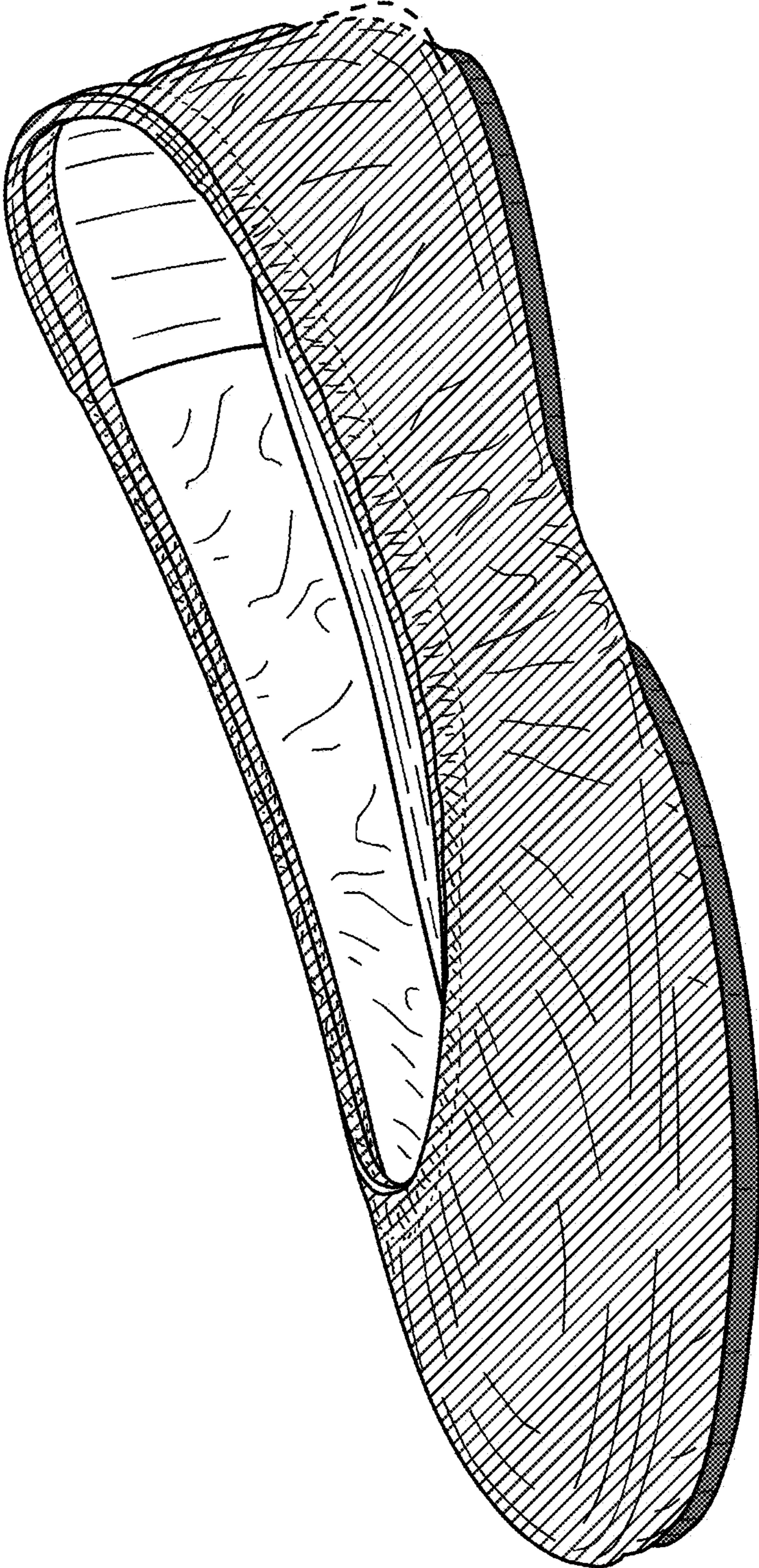

FIG. 29



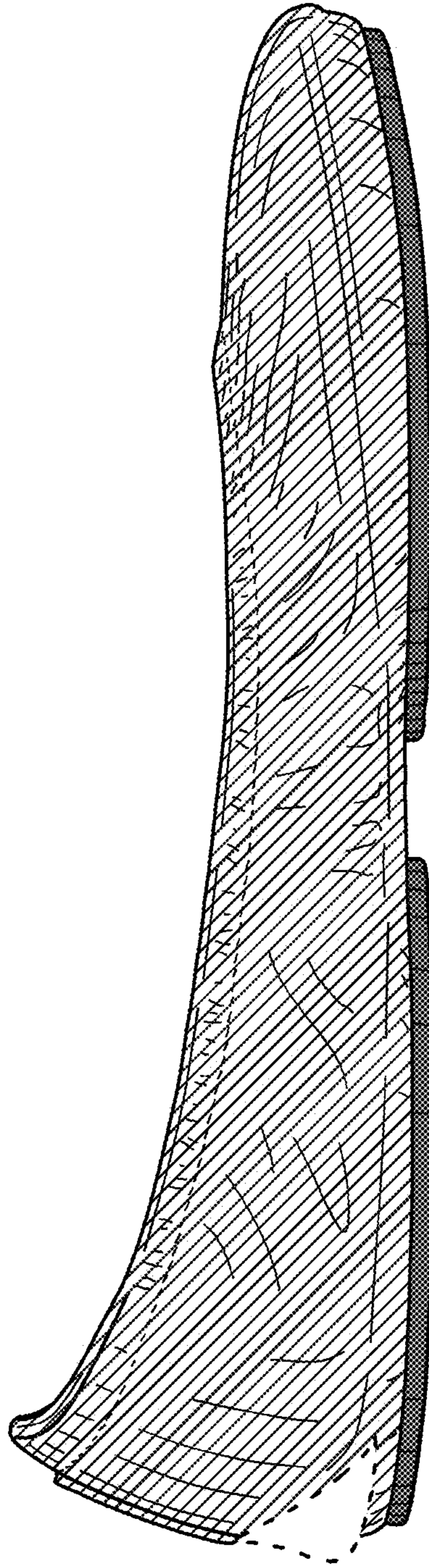

FIG. 30

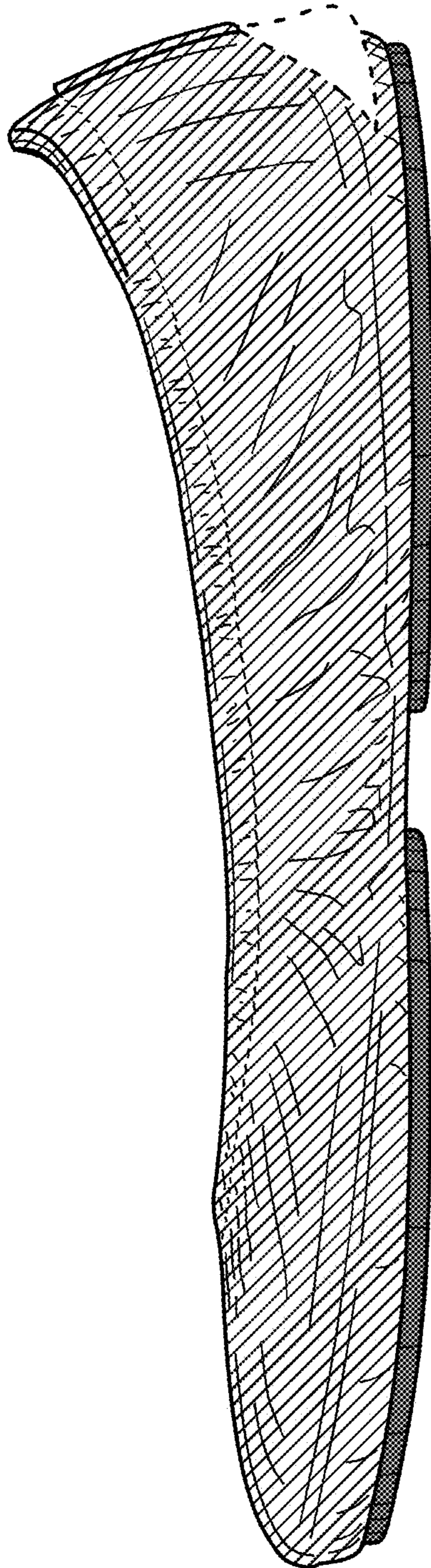

FIG. 31



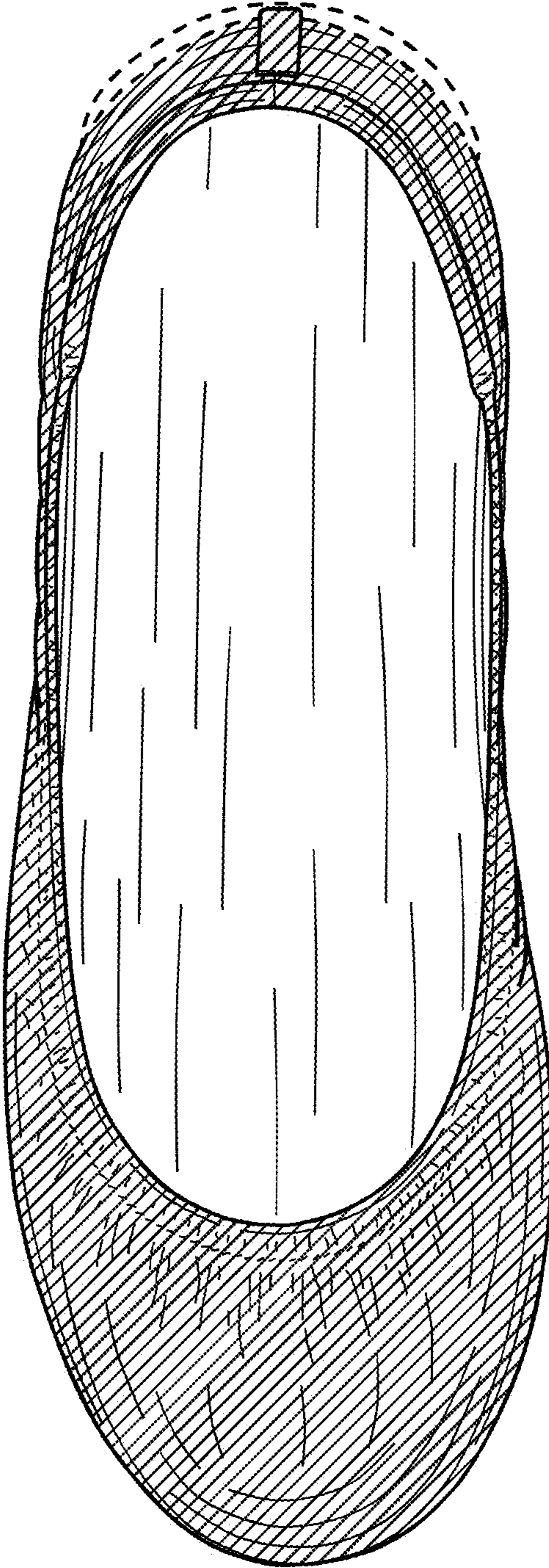

FIG. 32



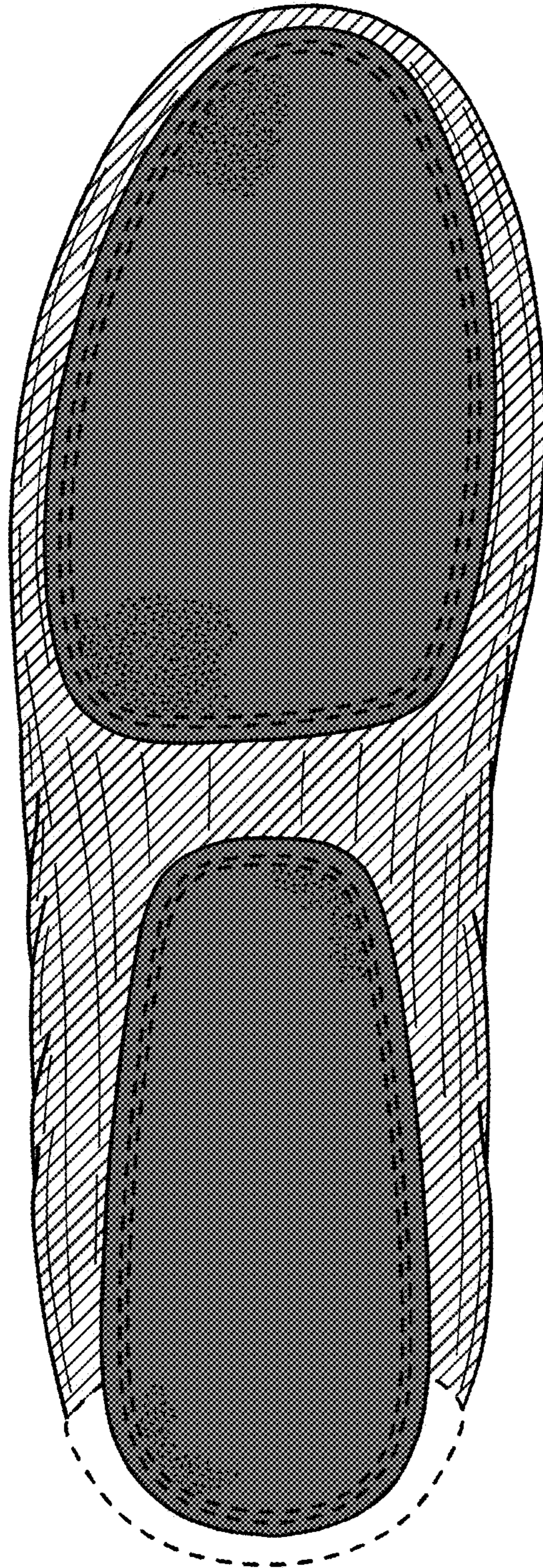

FIG. 33



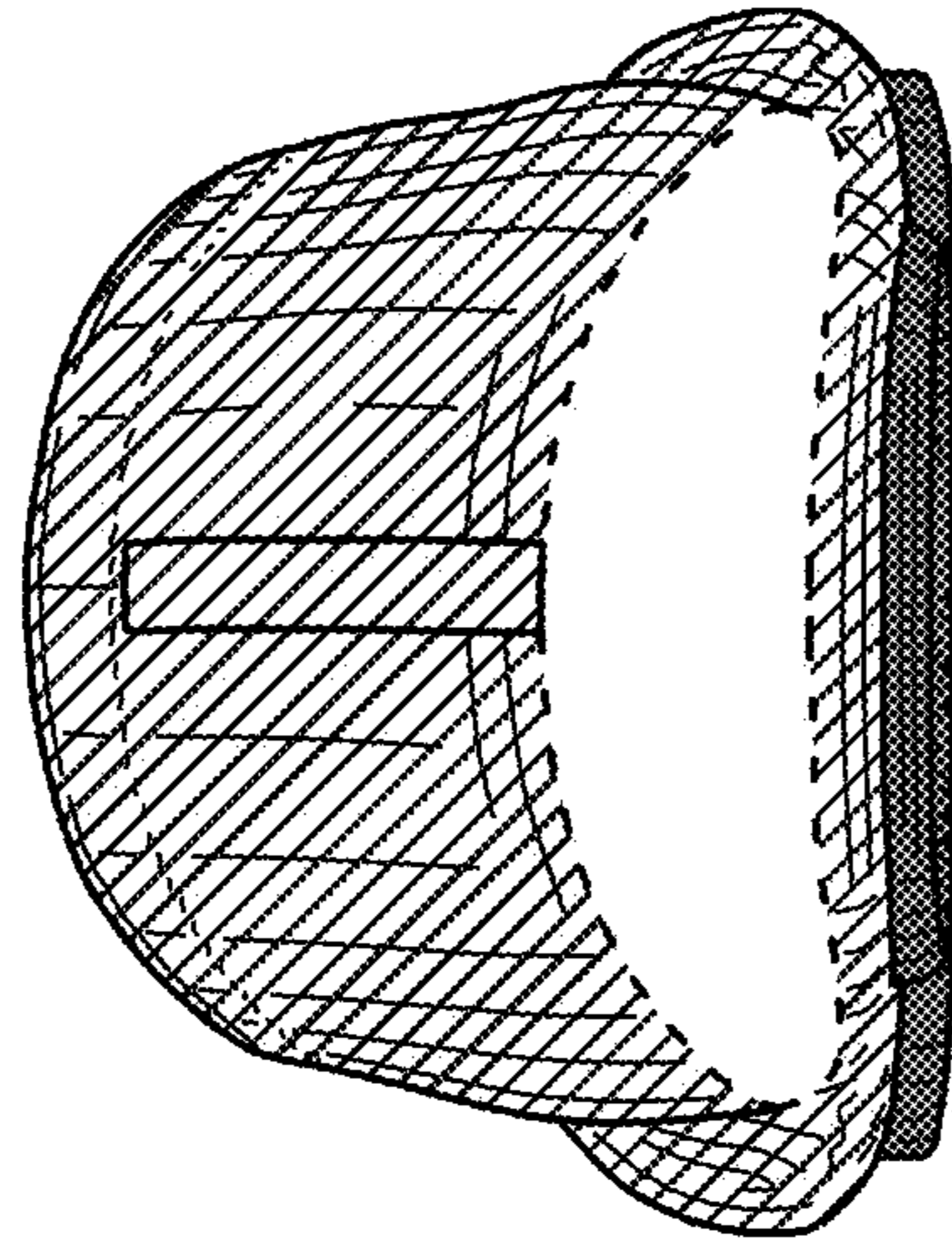

FIG. 34

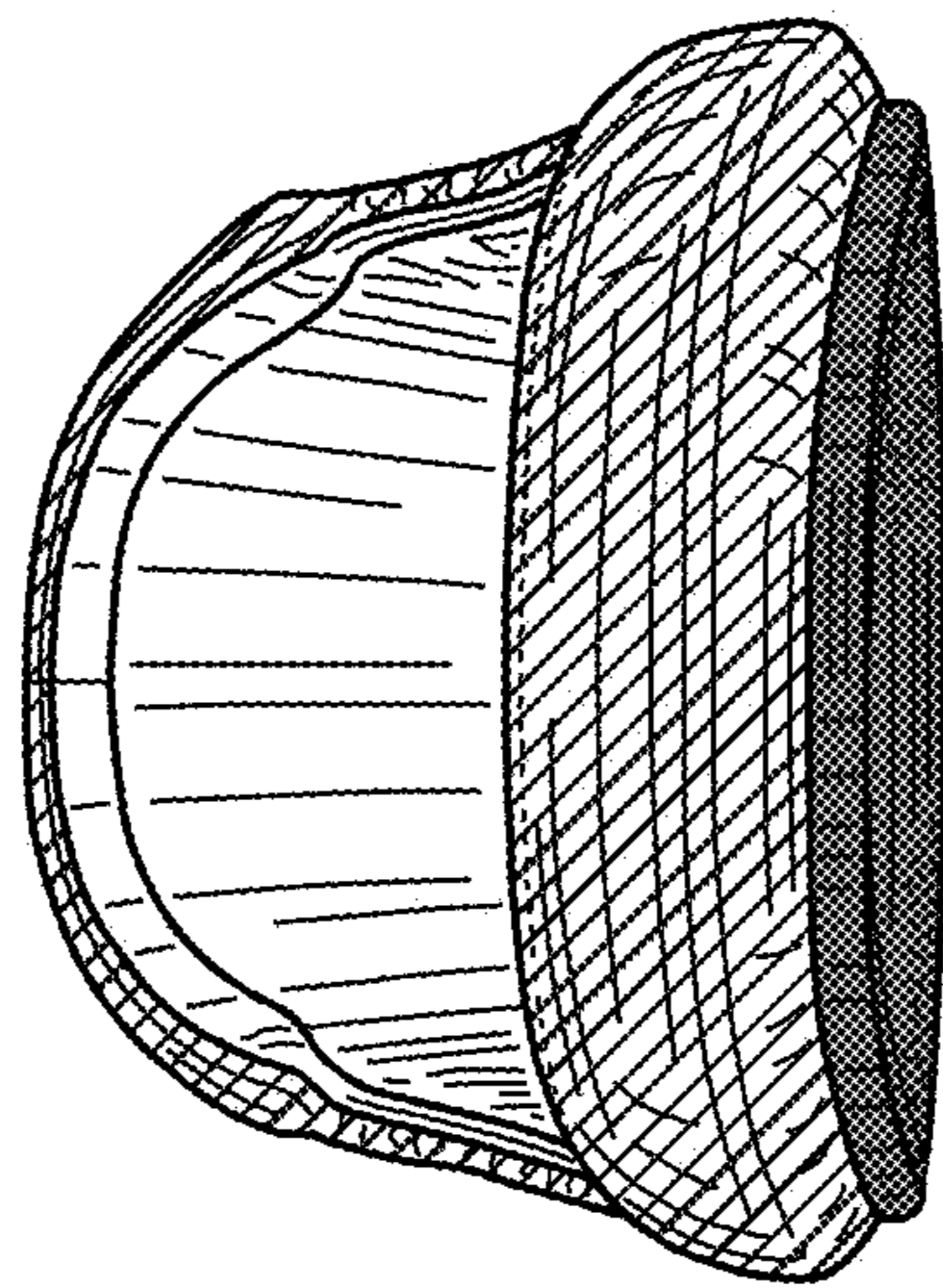

FIG. 35

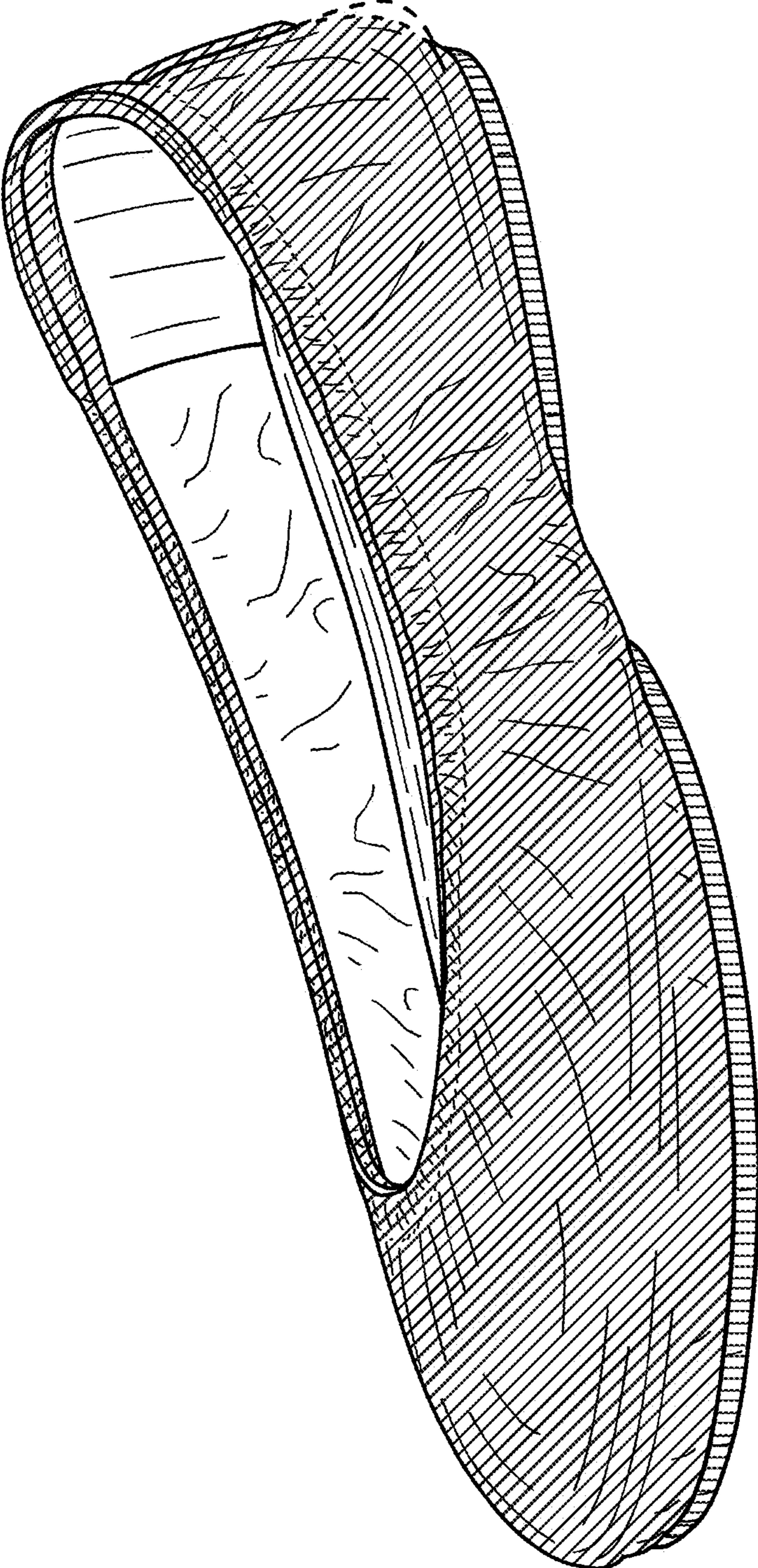

FIG. 36



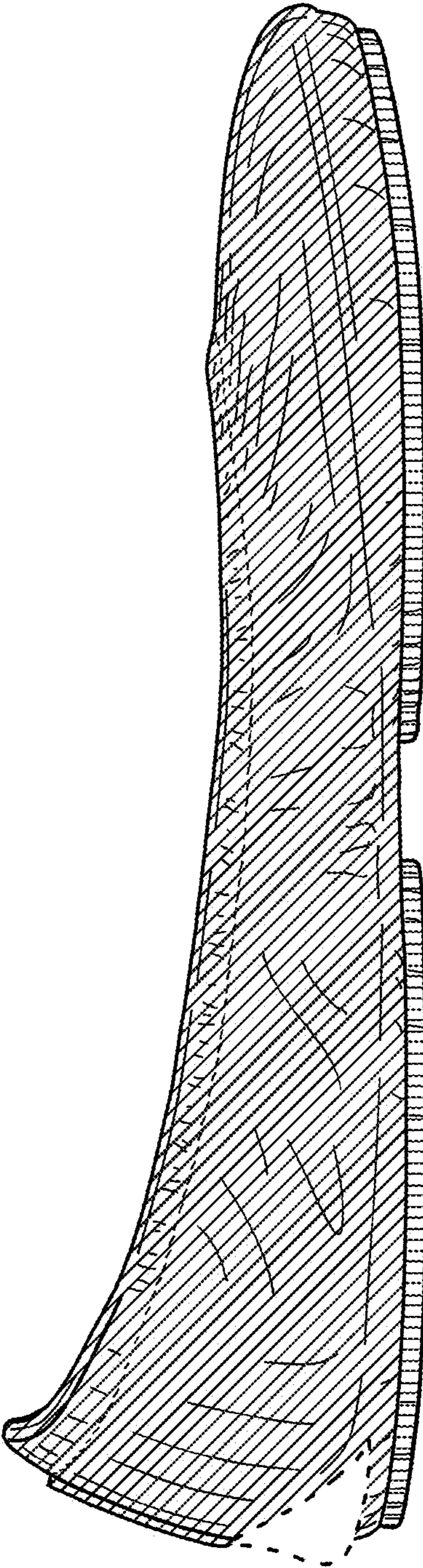

FIG. 37

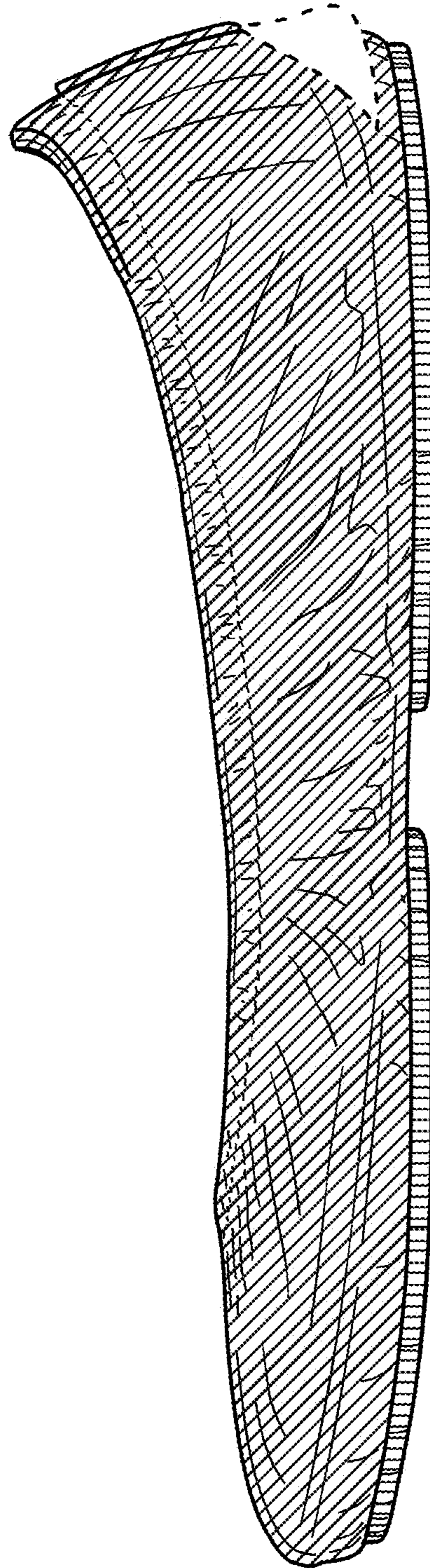

FIG. 38



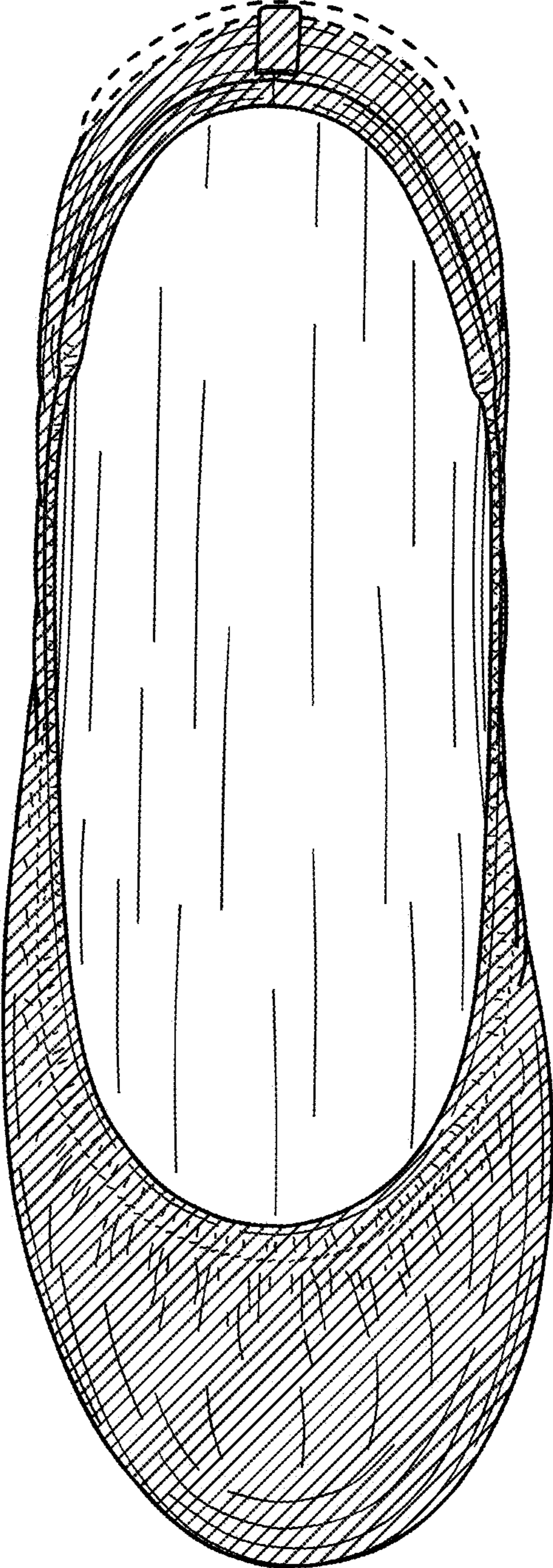

FIG. 39

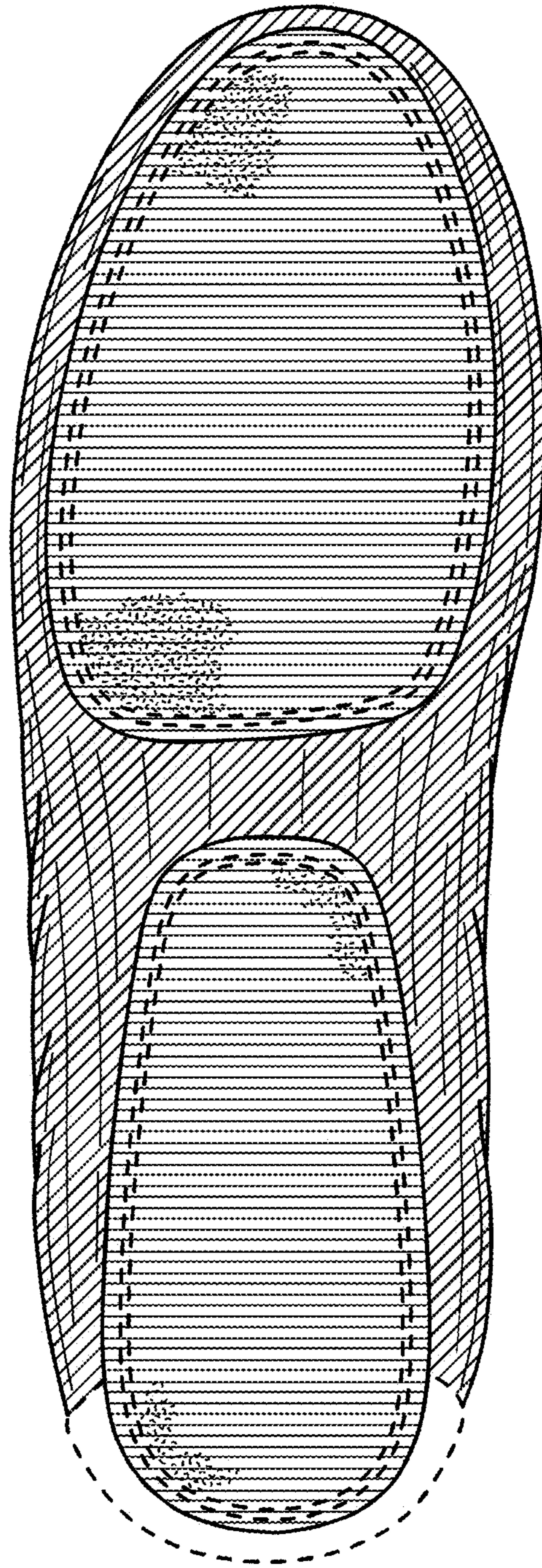

FIG. 40



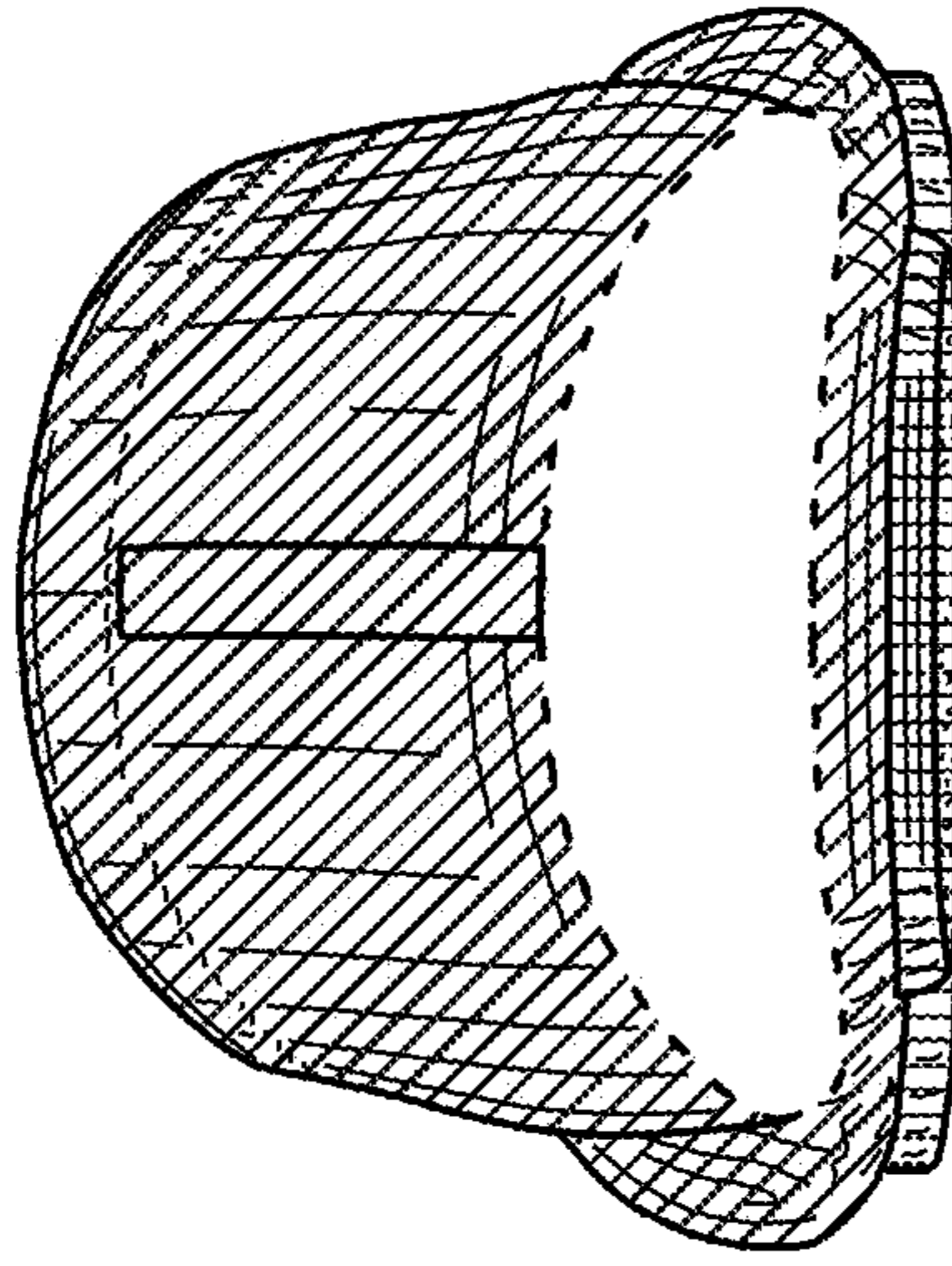

FIG. 41

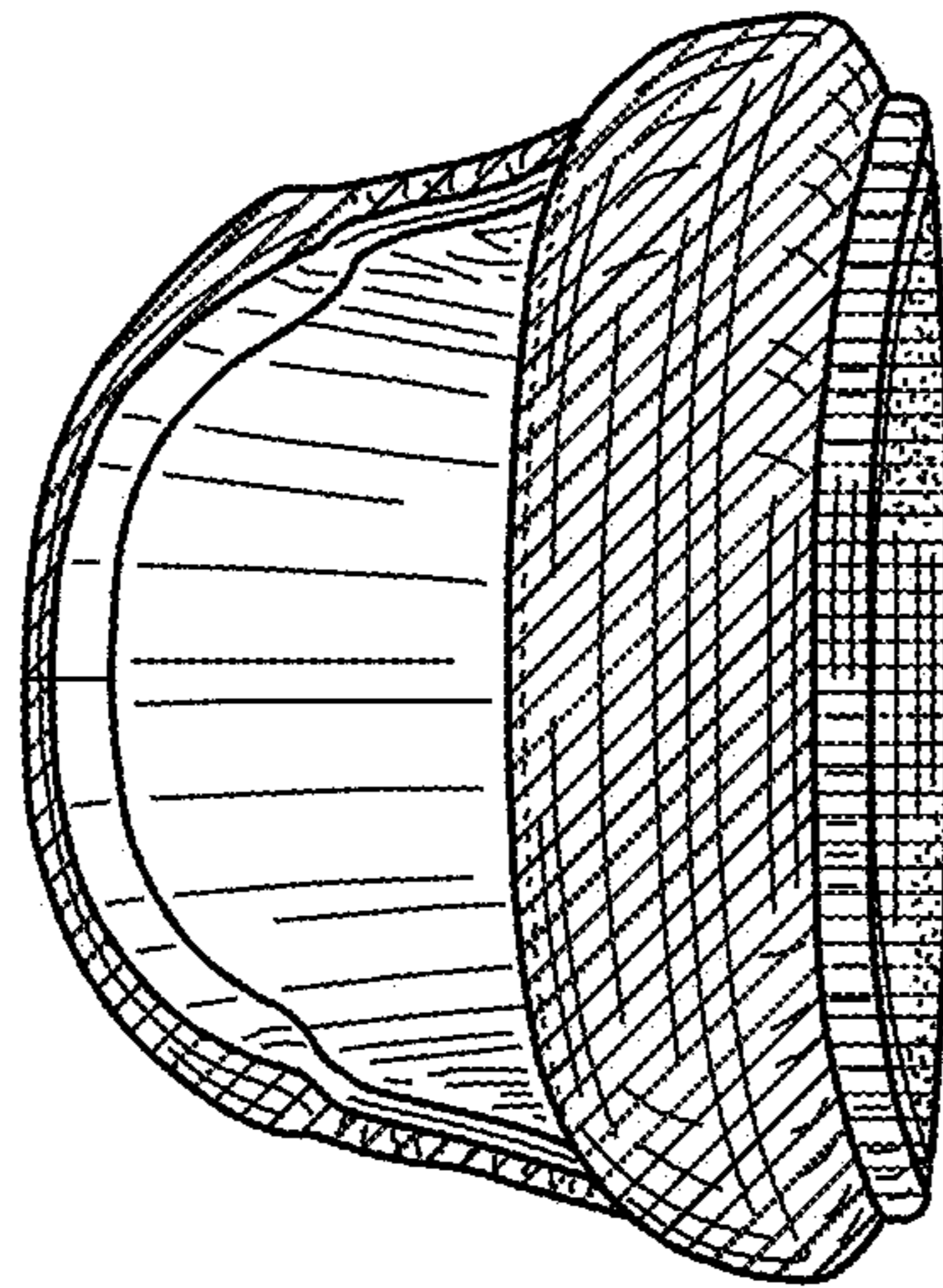

FIG. 42

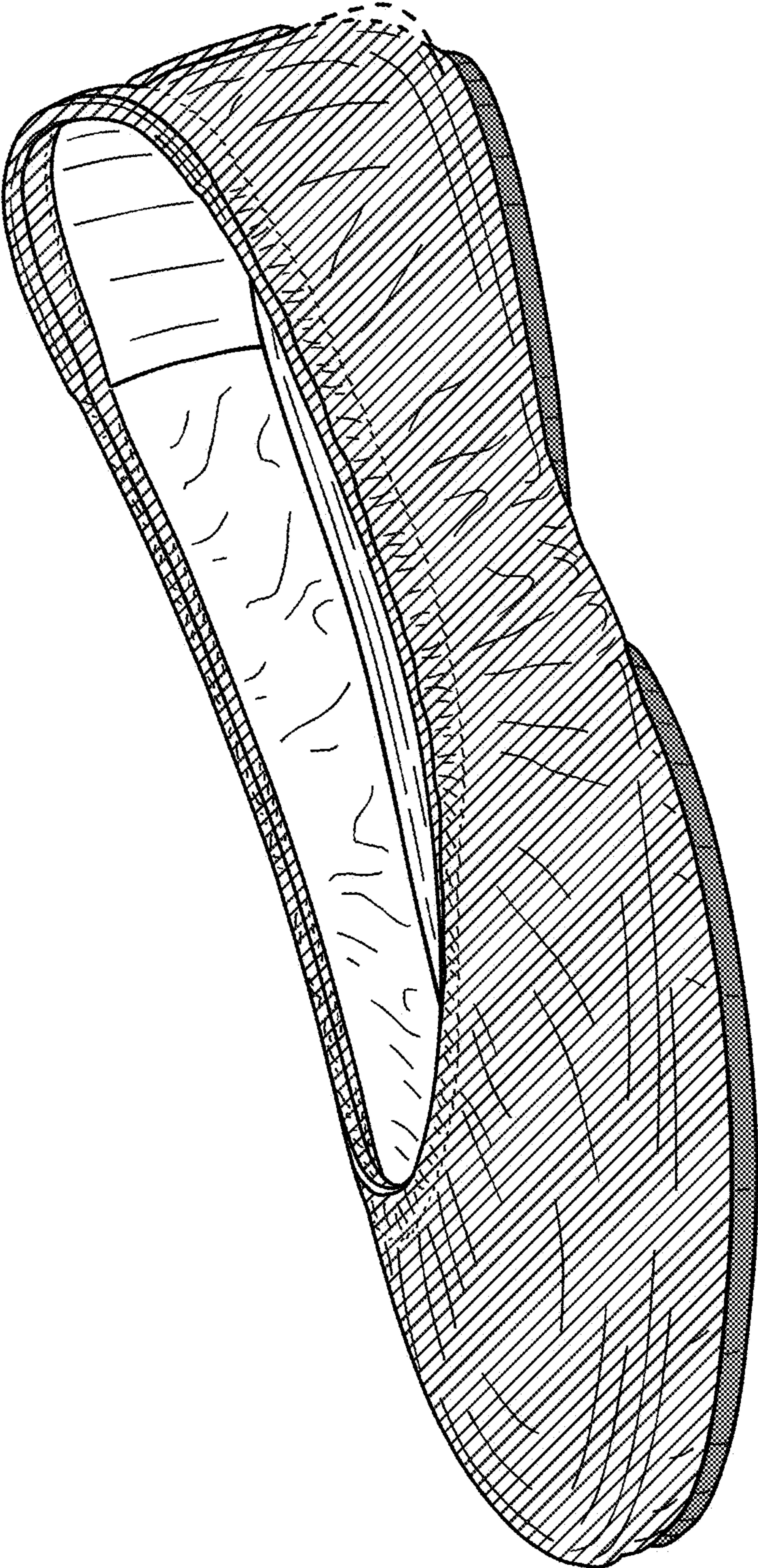

FIG. 43



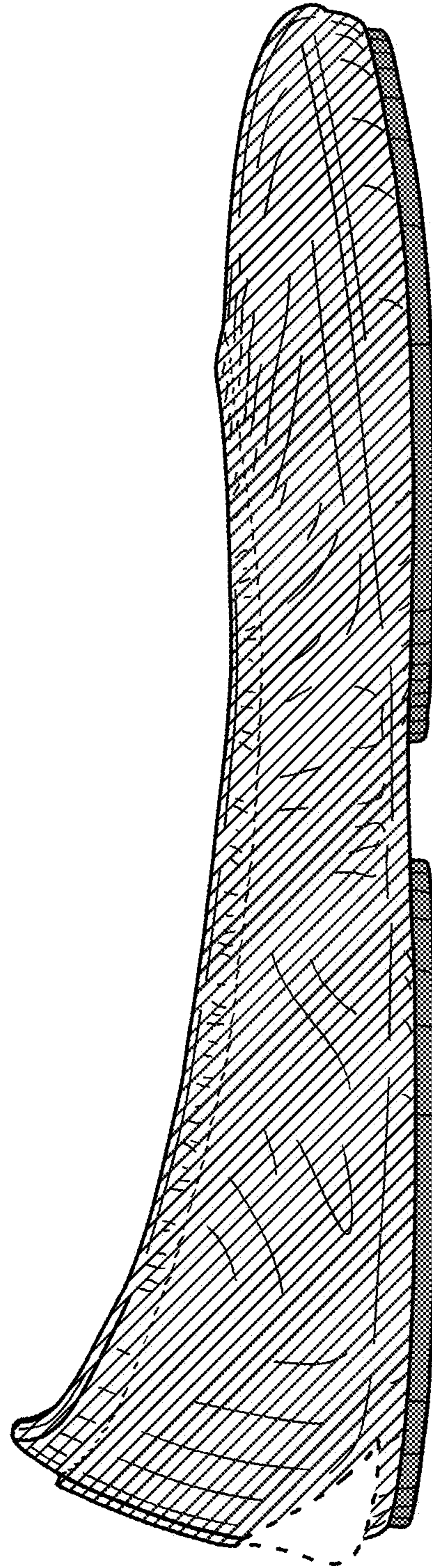

FIG. 44

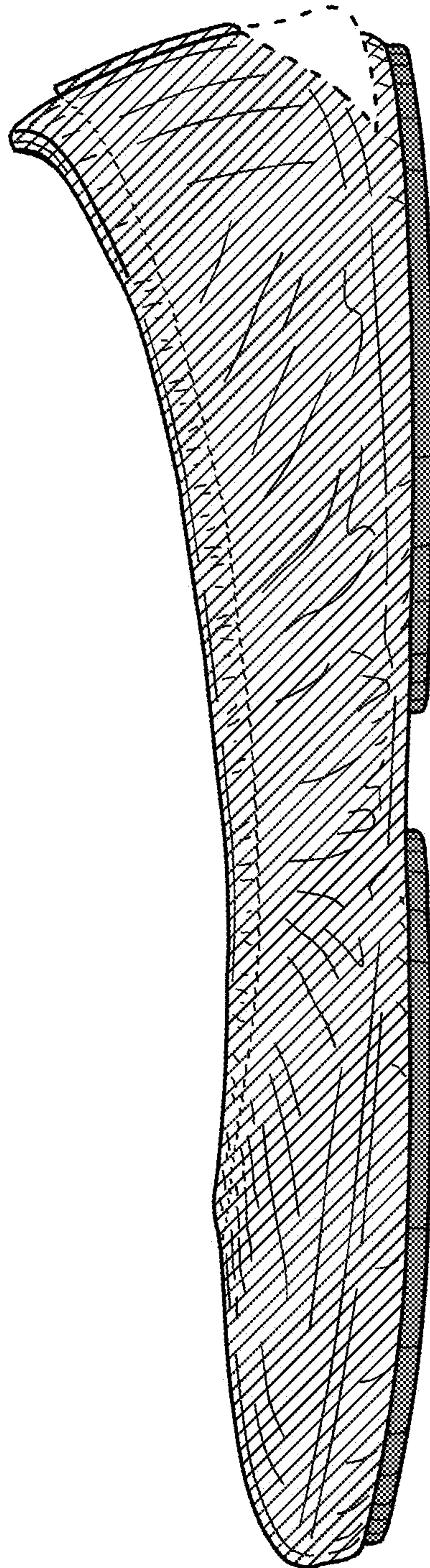

FIG. 45



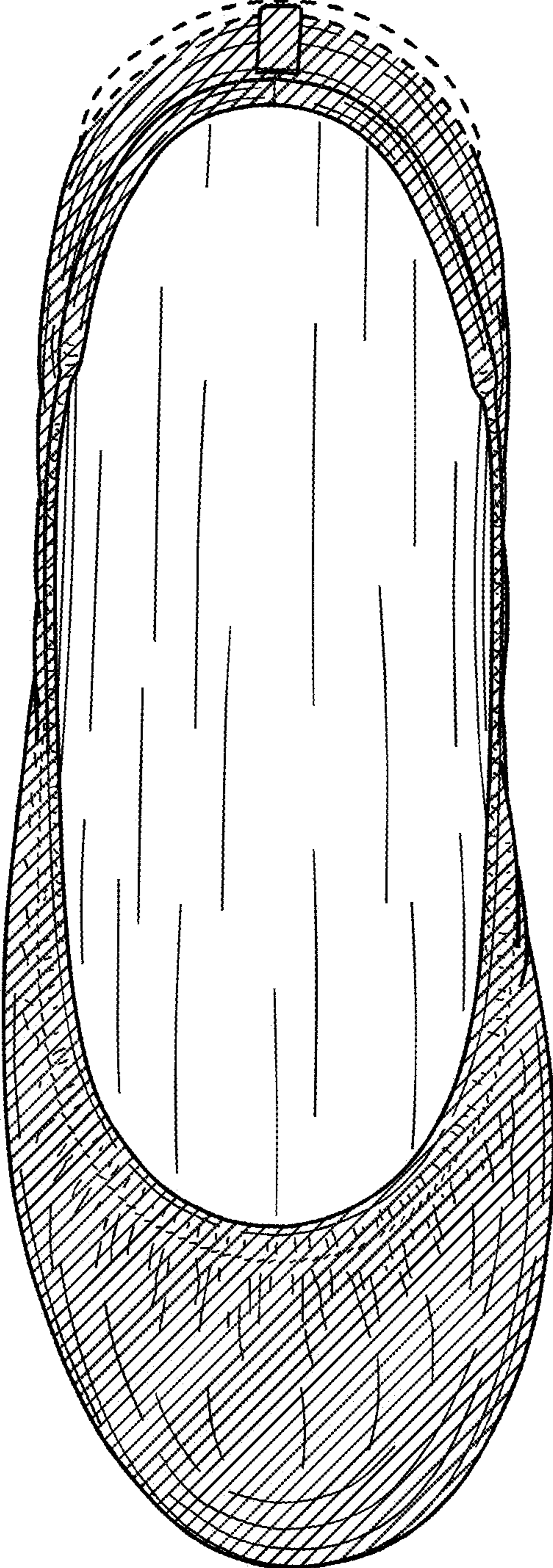

FIG. 46

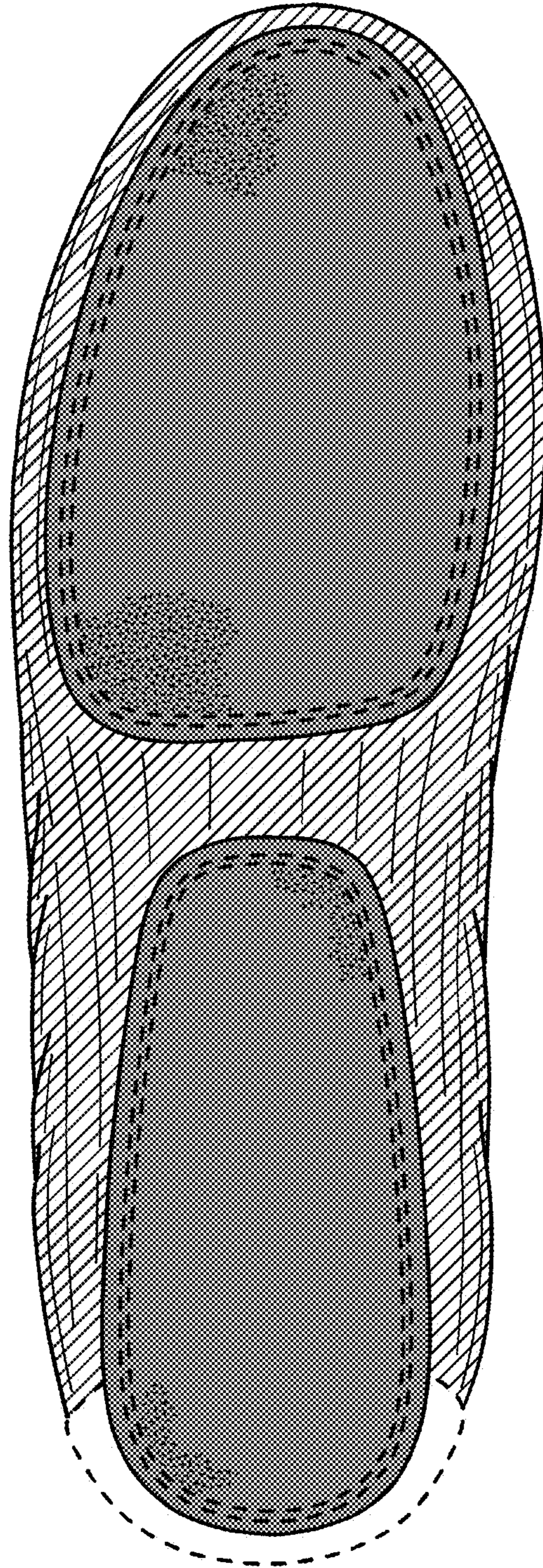

FIG. 47



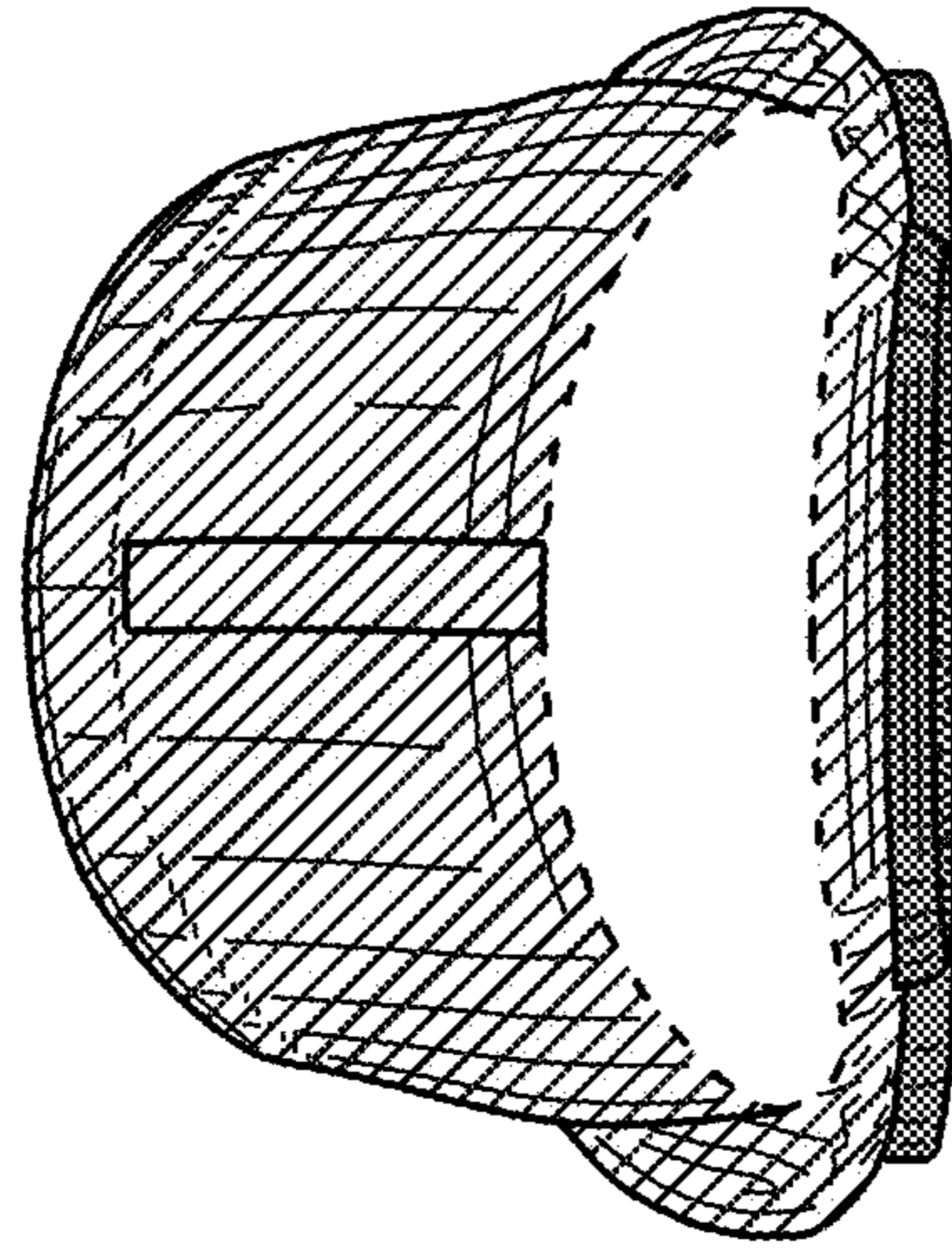

FIG. 49

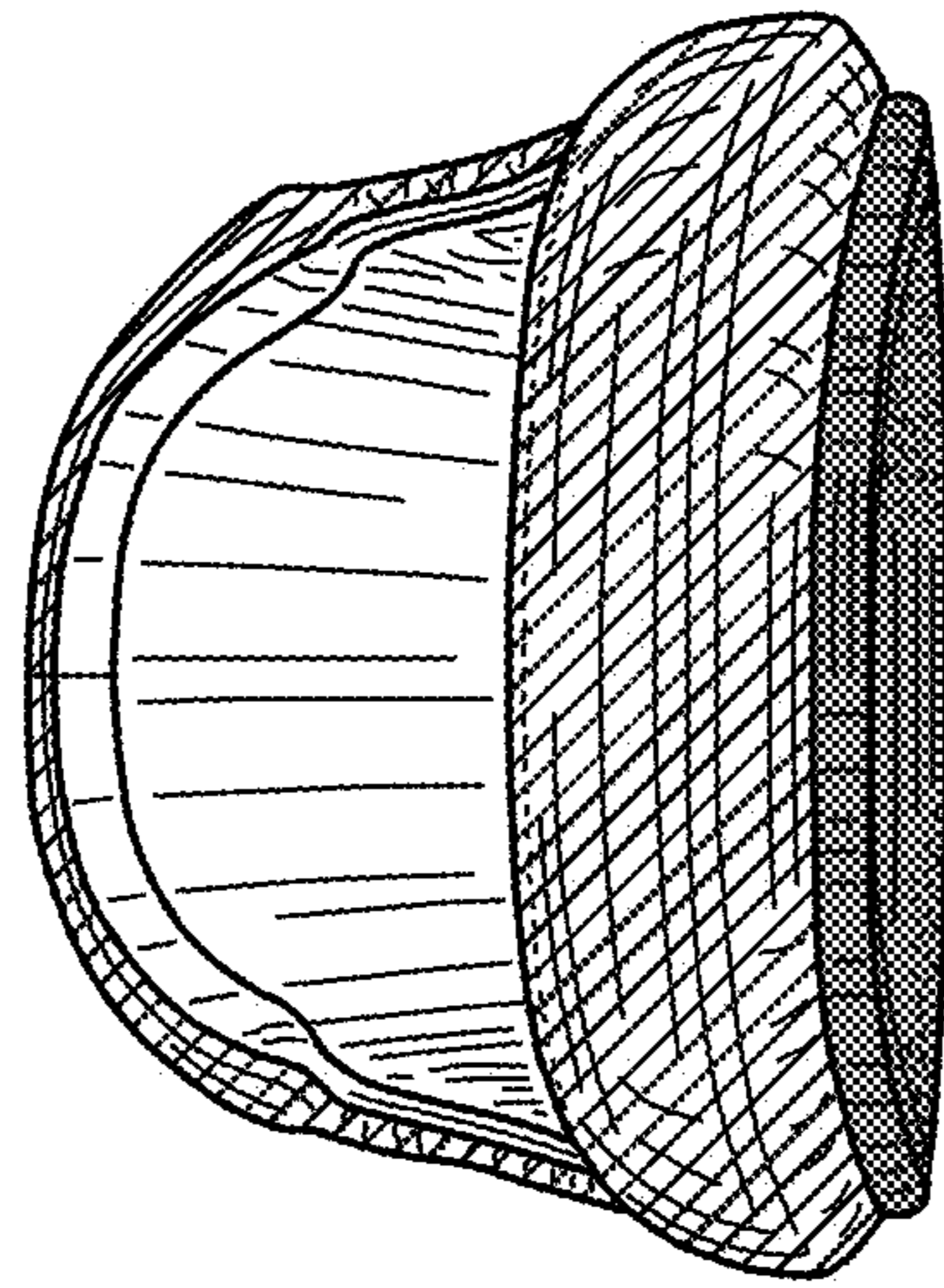

FIG. 48

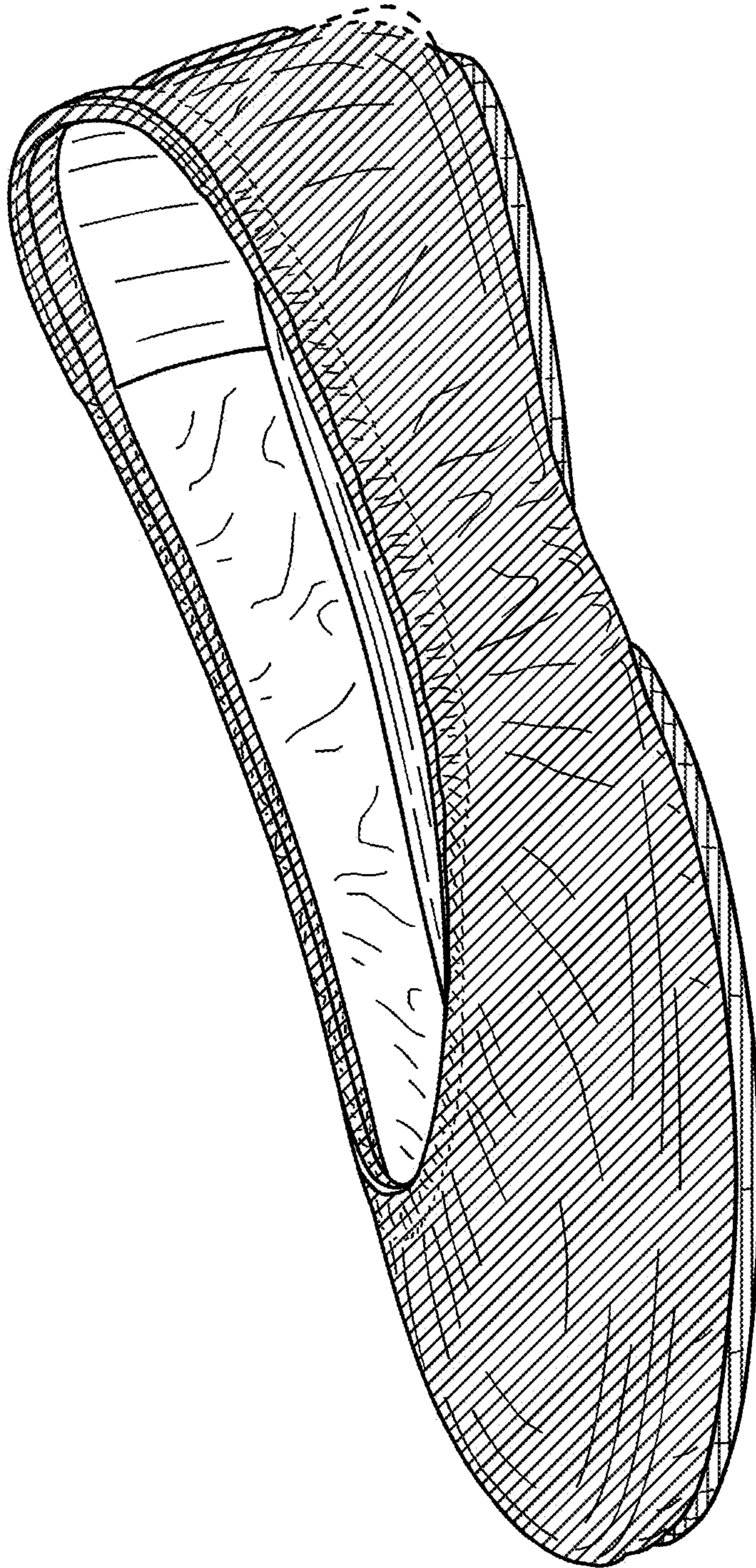

FIG. 50



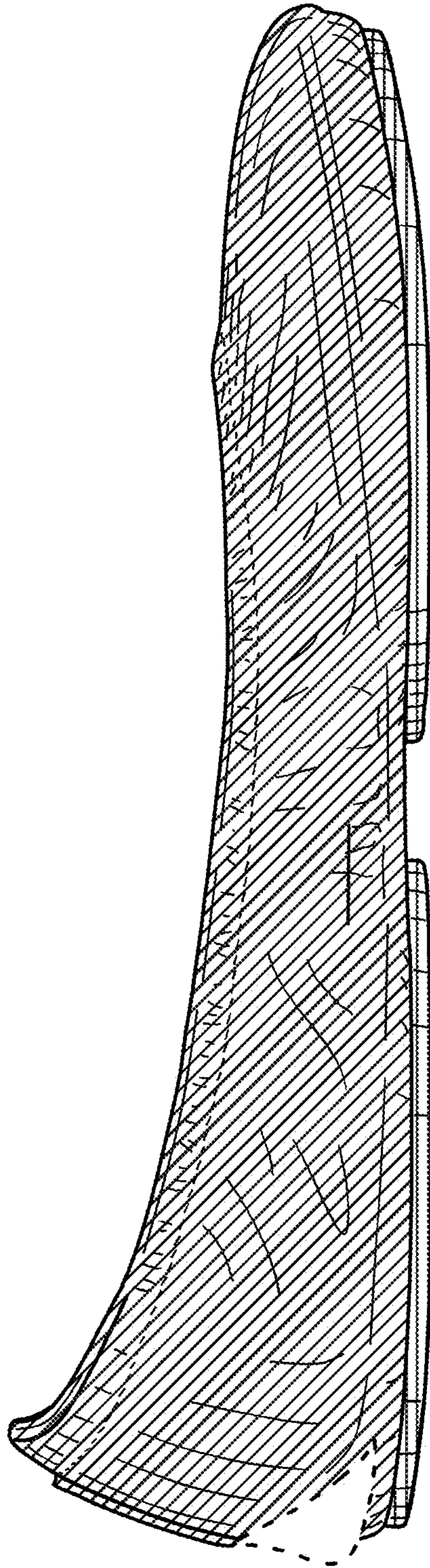

FIG. 51

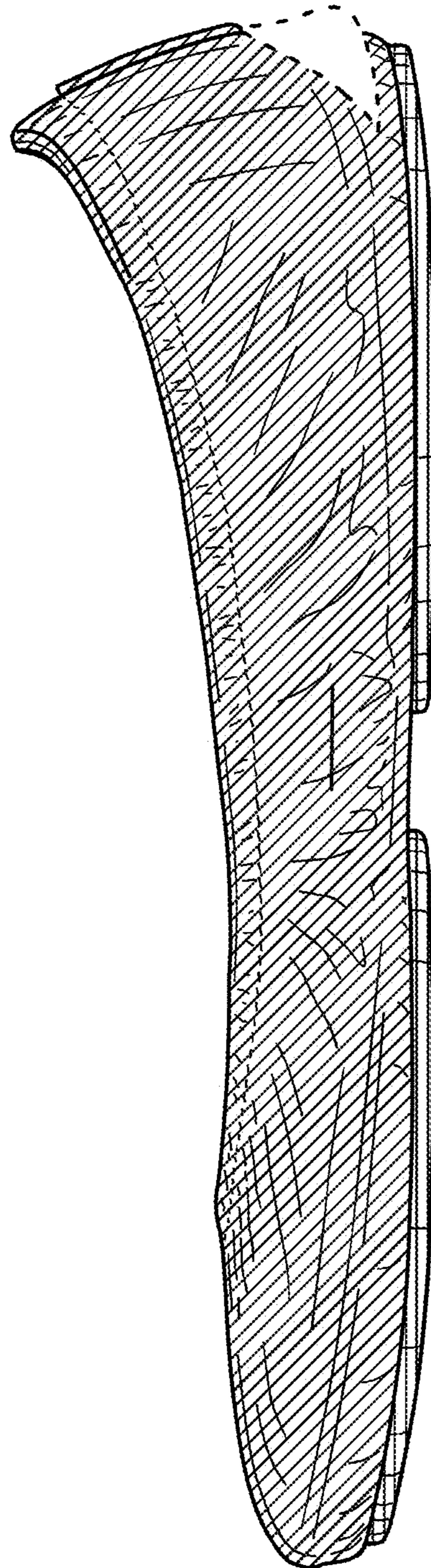

FIG. 52



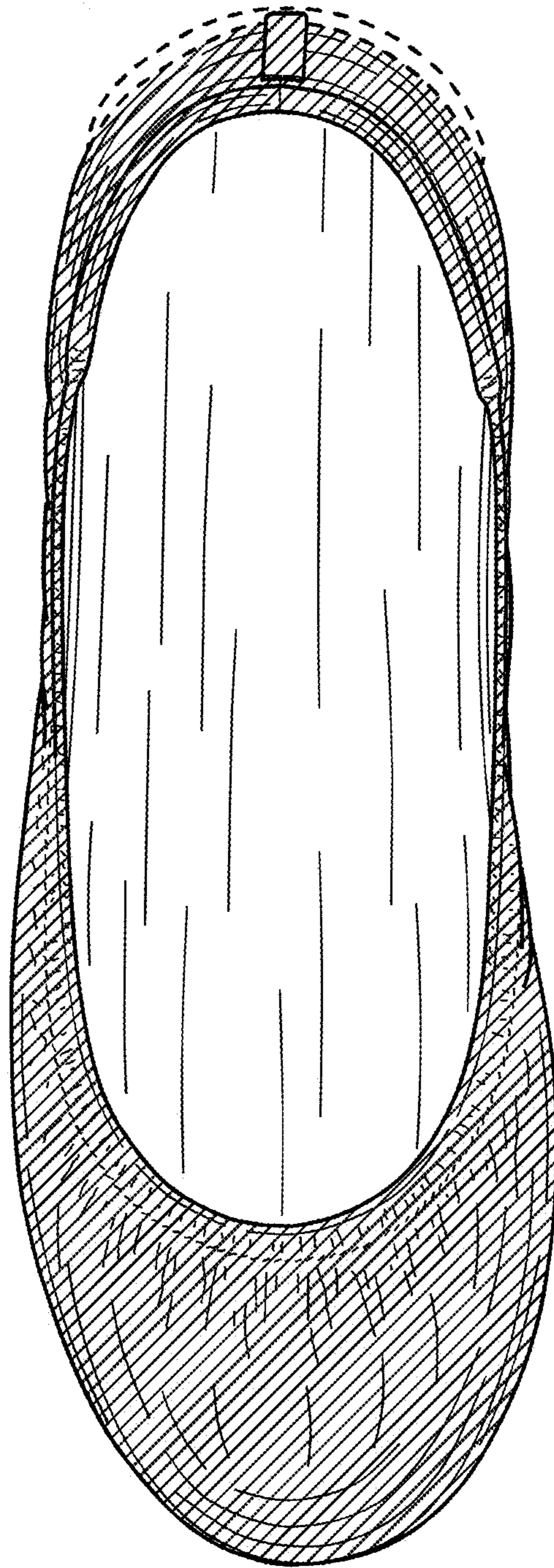

FIG. 53

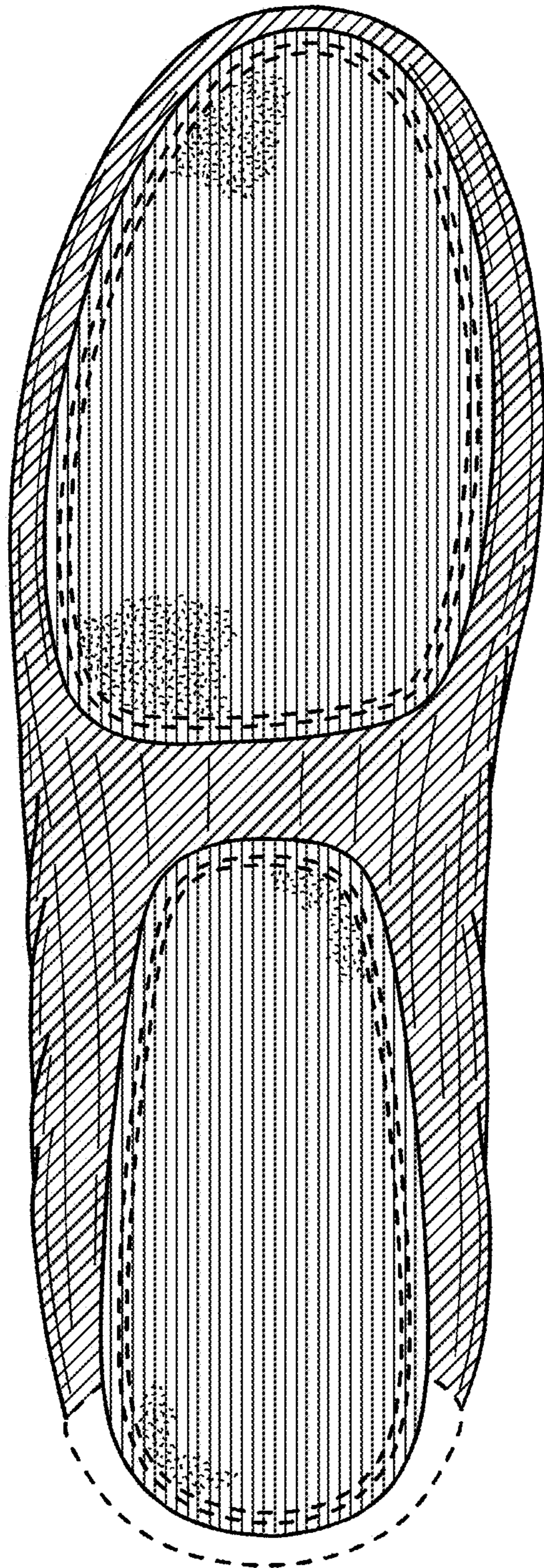

FIG. 54



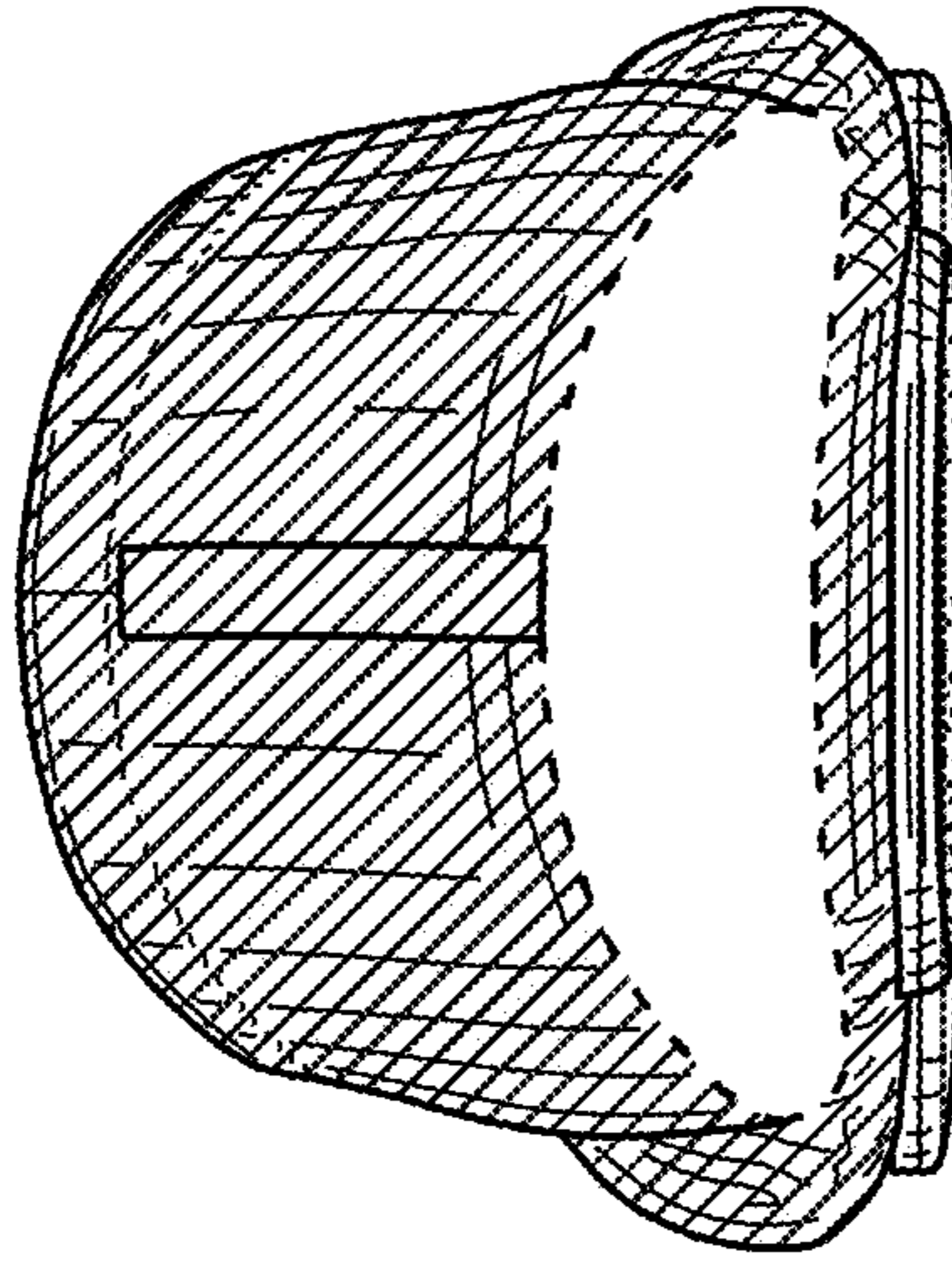

FIG. 56

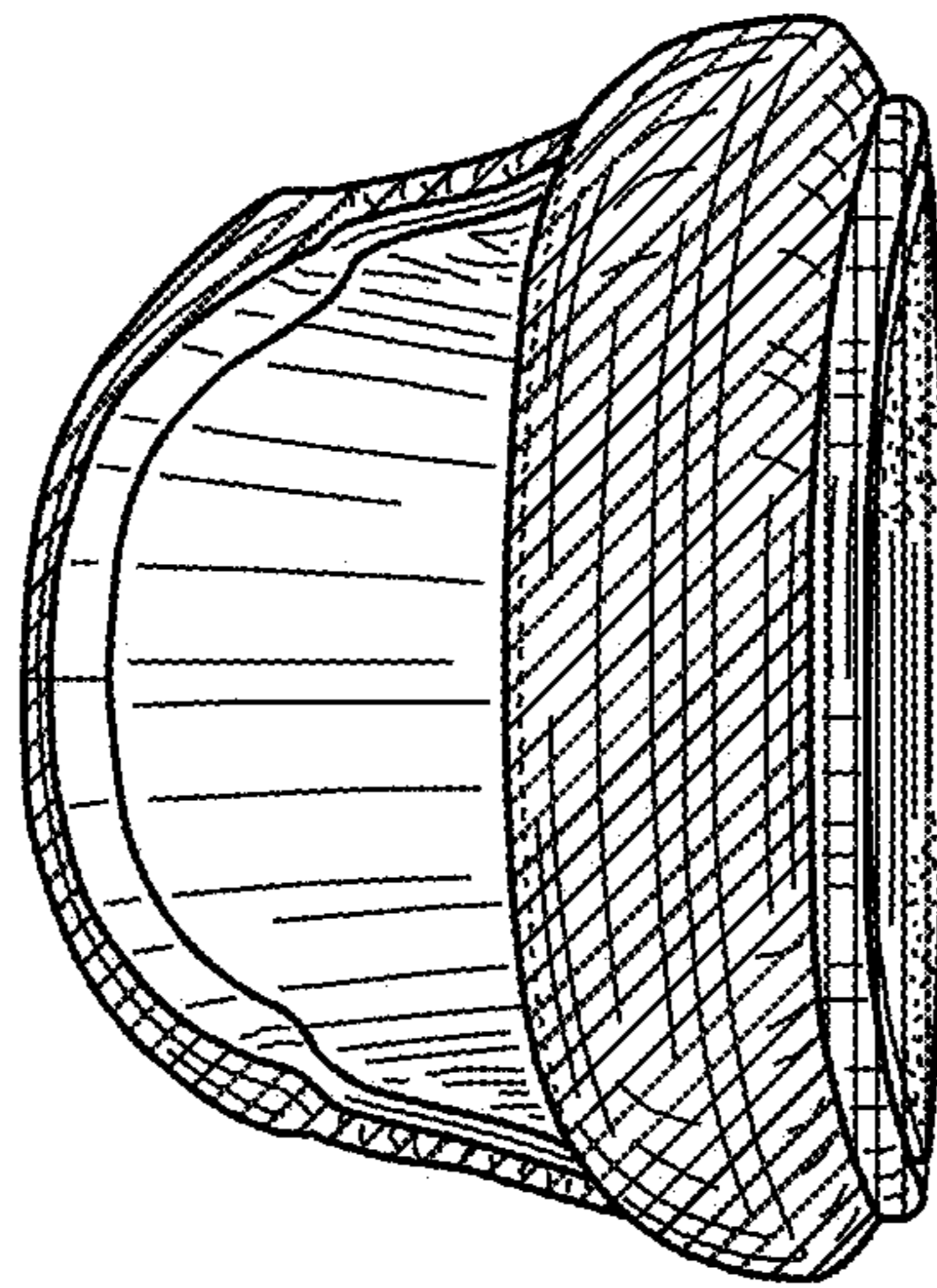

FIG. 55

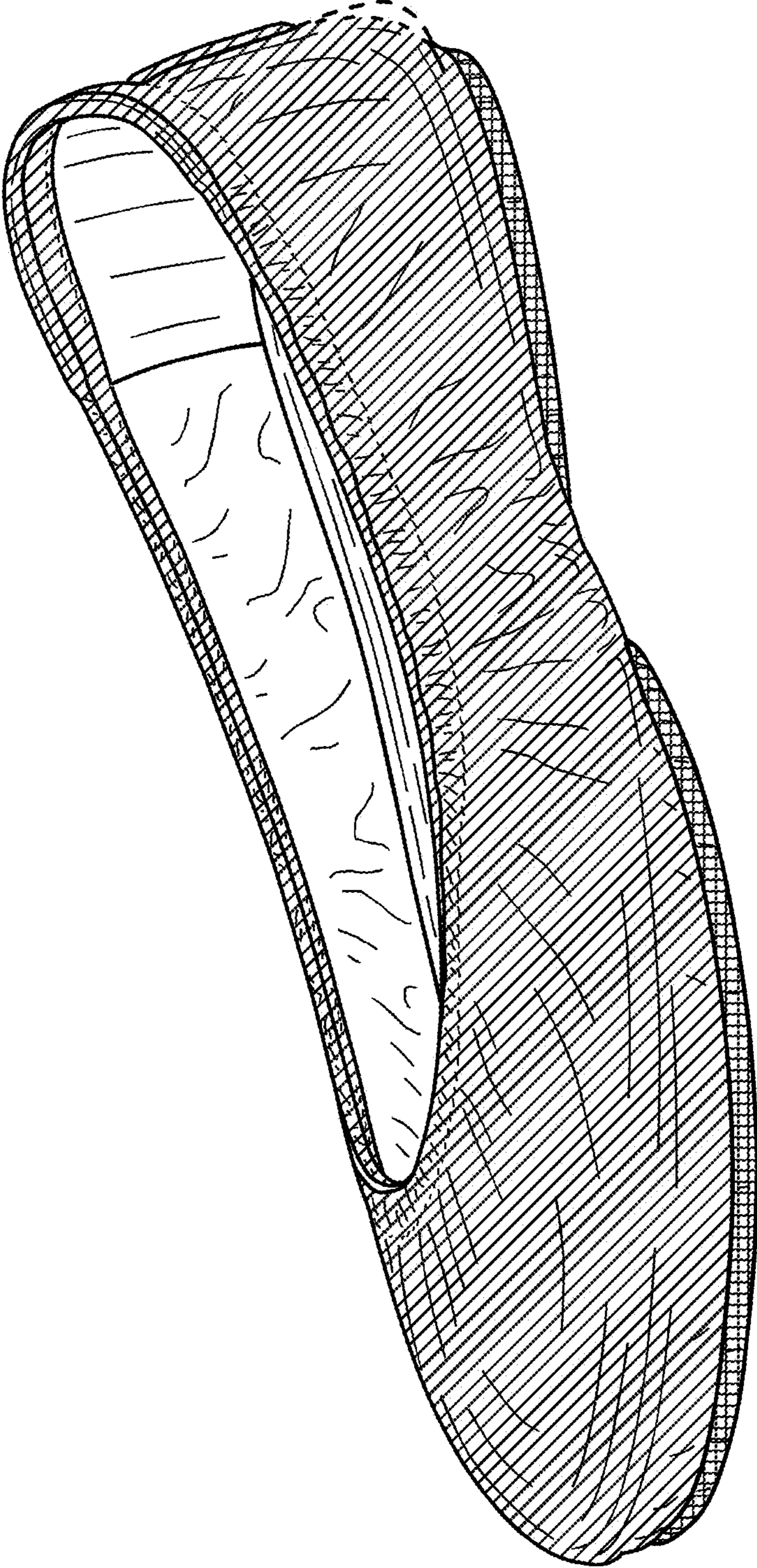

FIG. 57



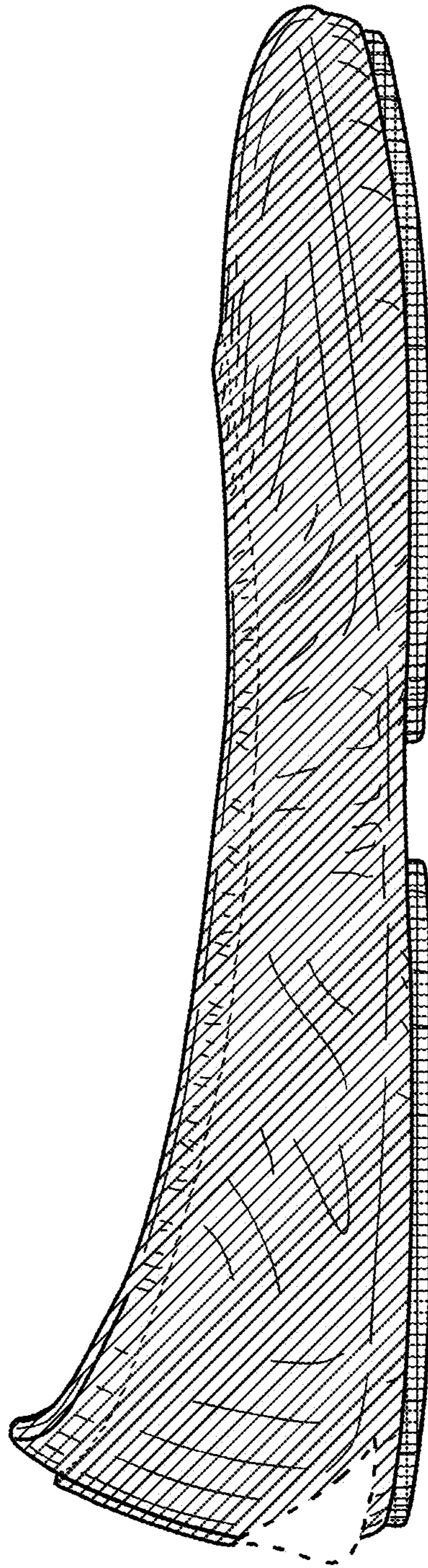

FIG. 58

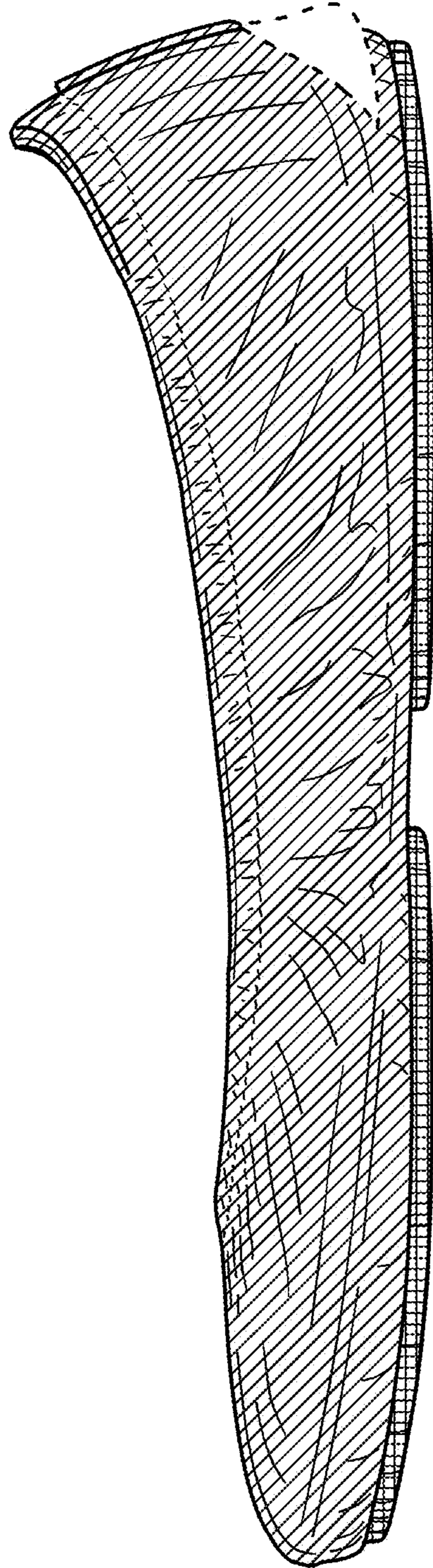

FIG. 59



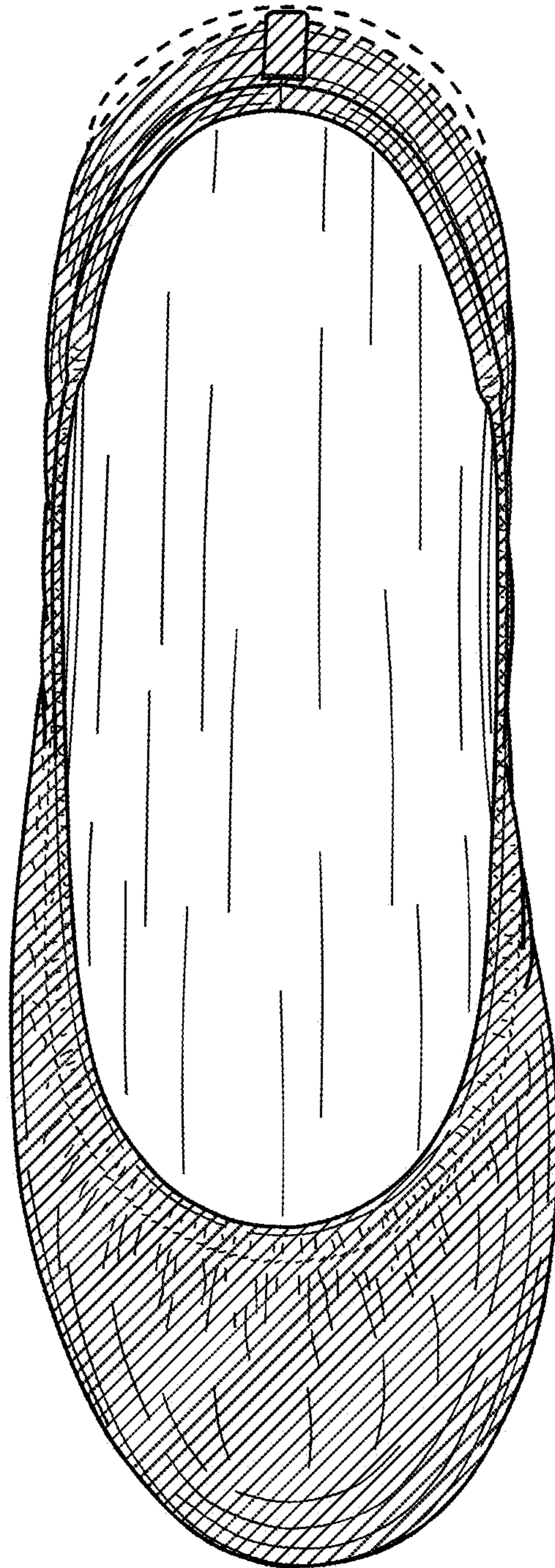

FIG. 60

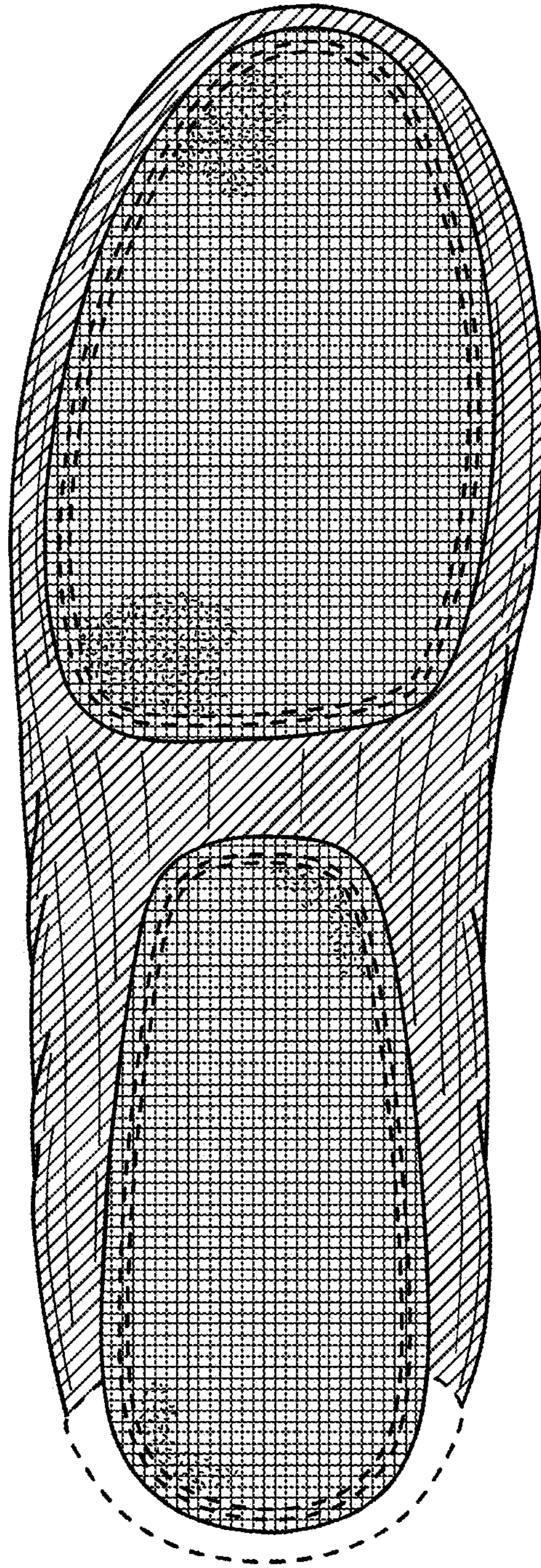

FIG. 61



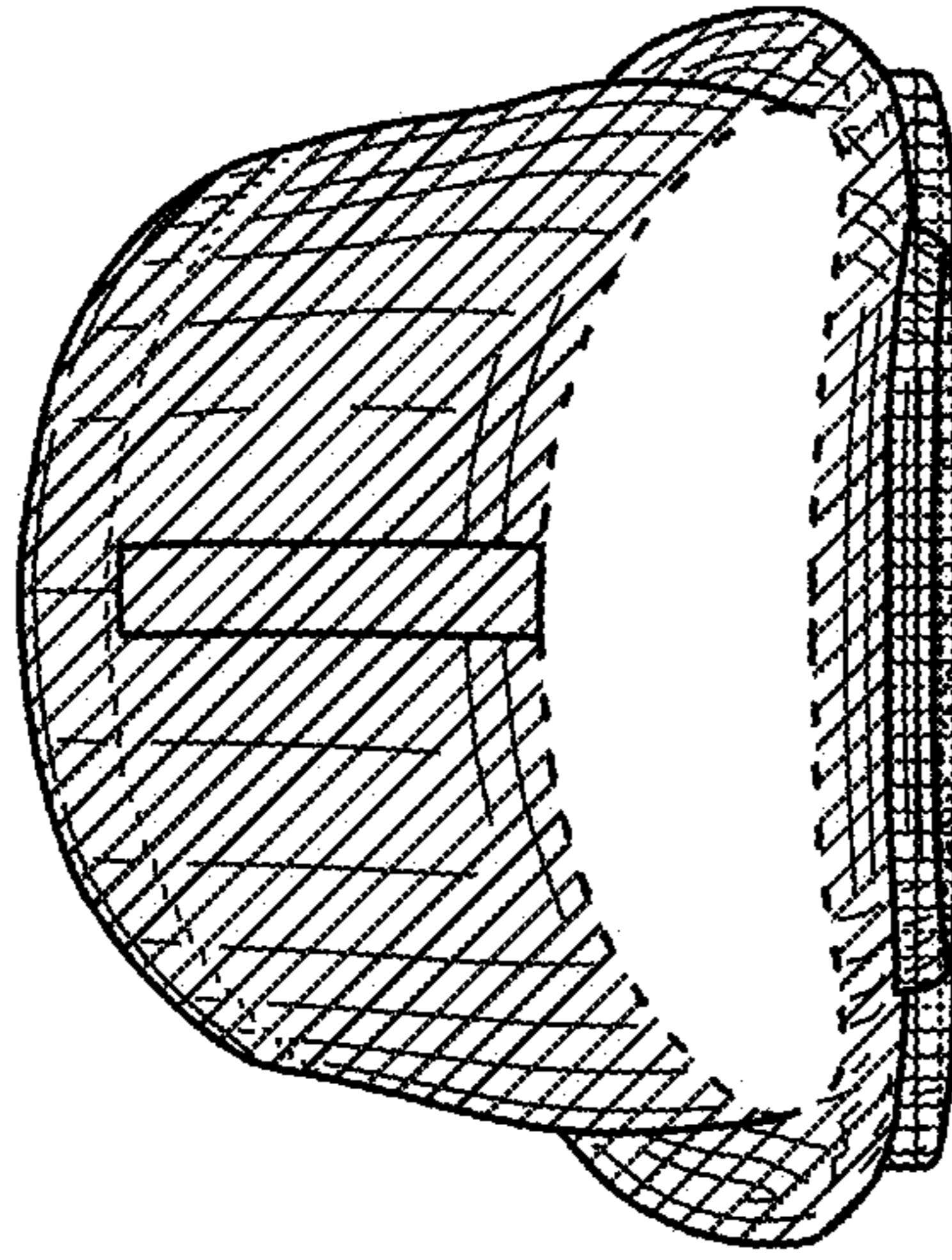

FIG. 62

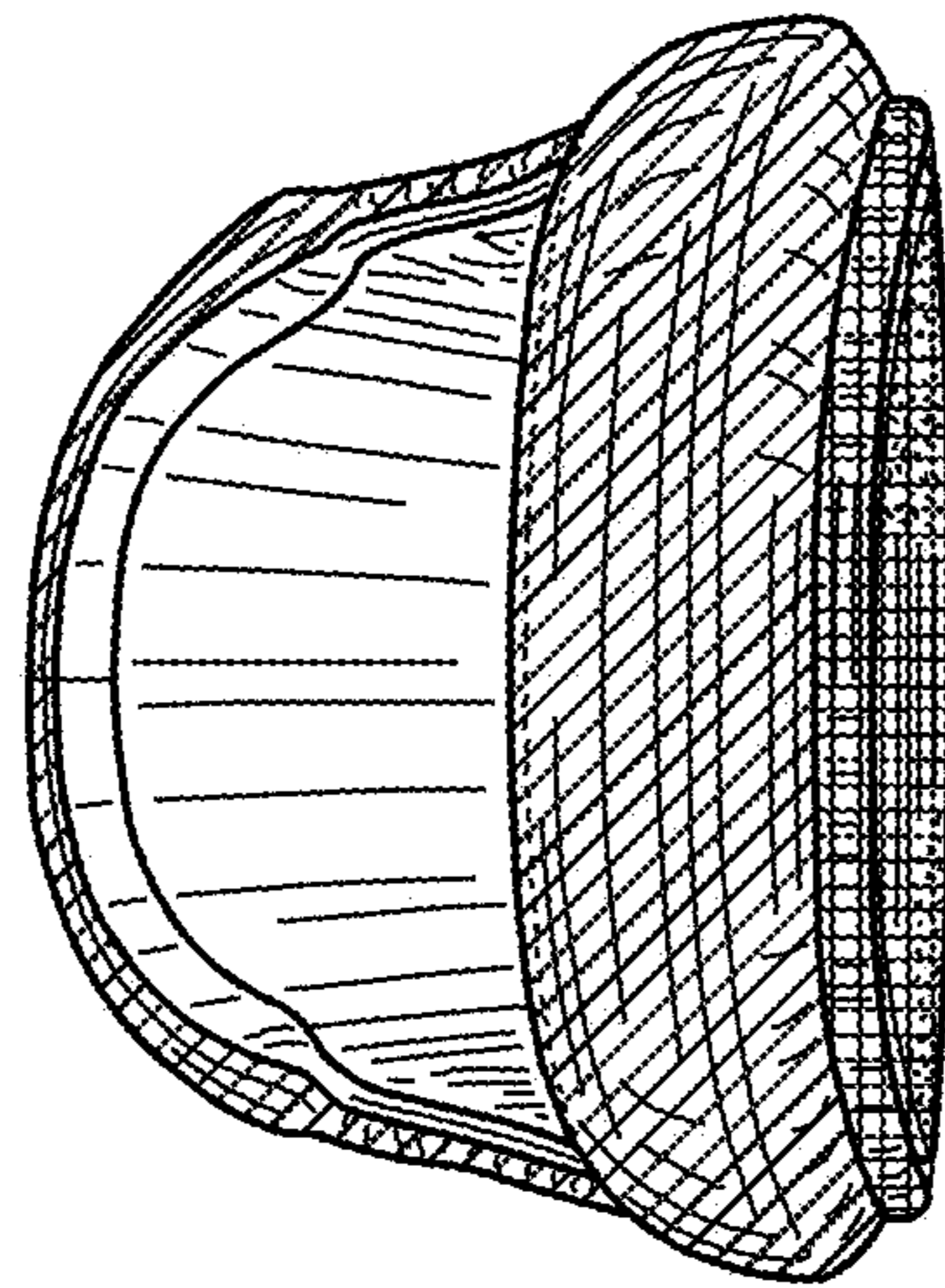

FIG. 63

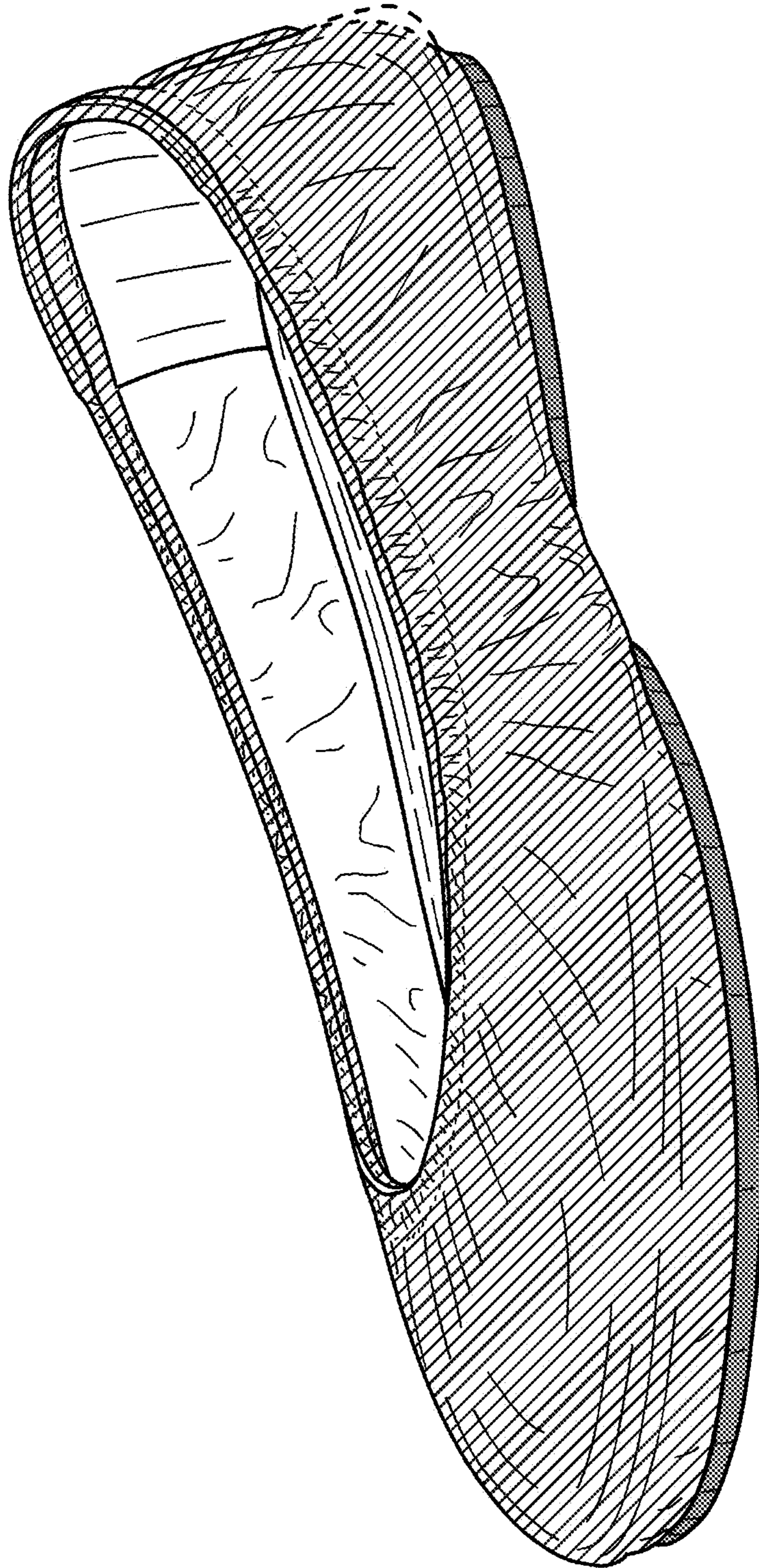

FIG. 64



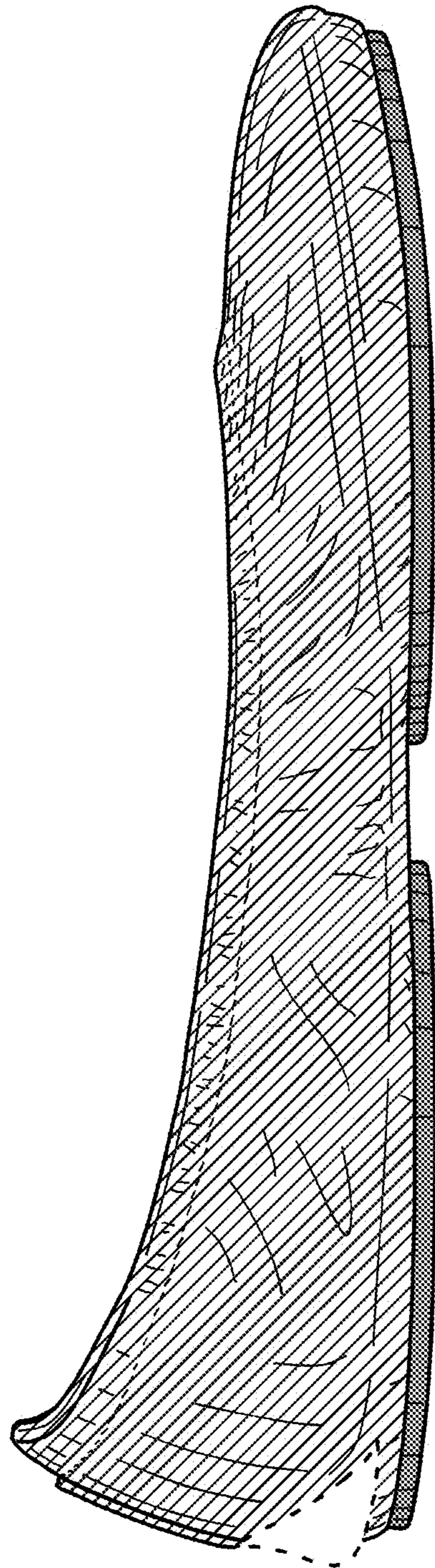

FIG. 65

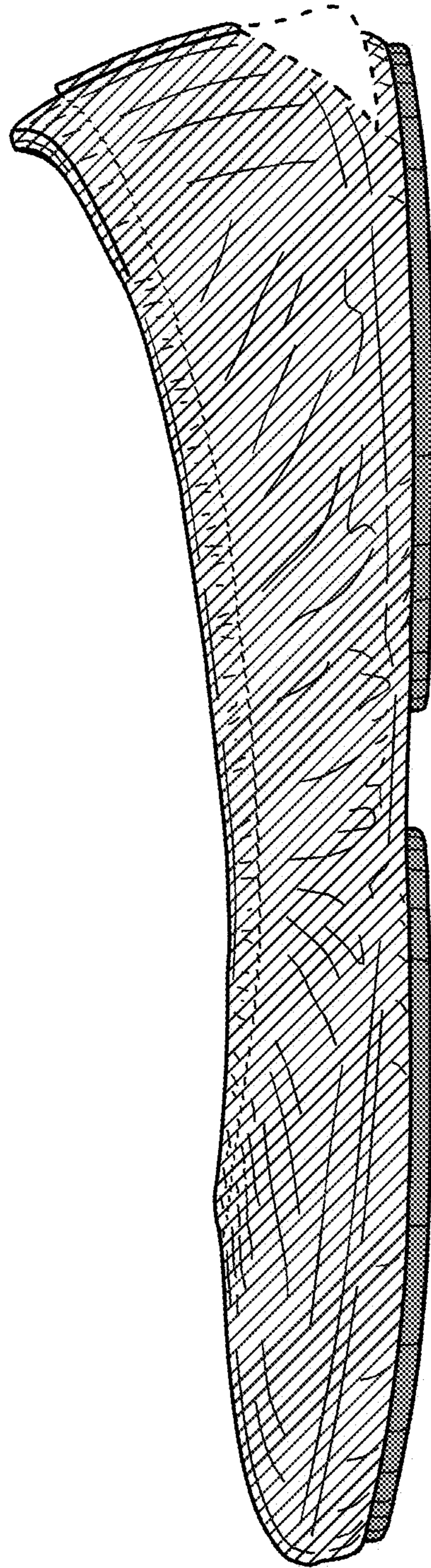

FIG. 66



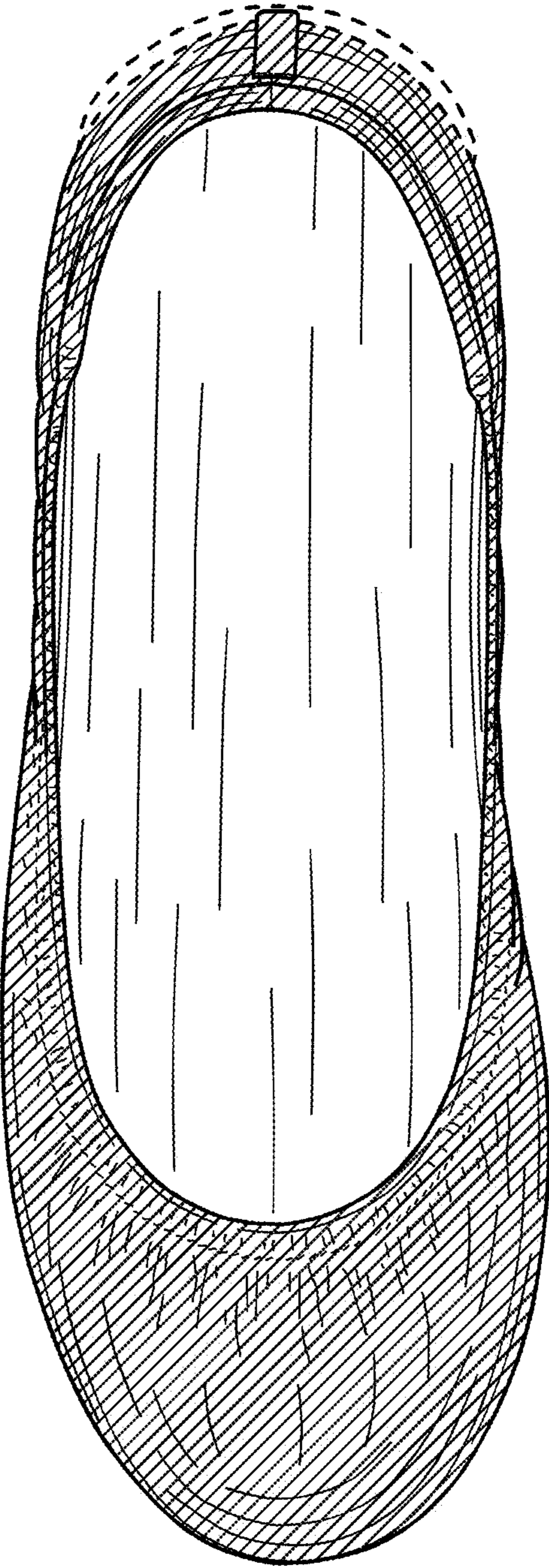

FIG. 67

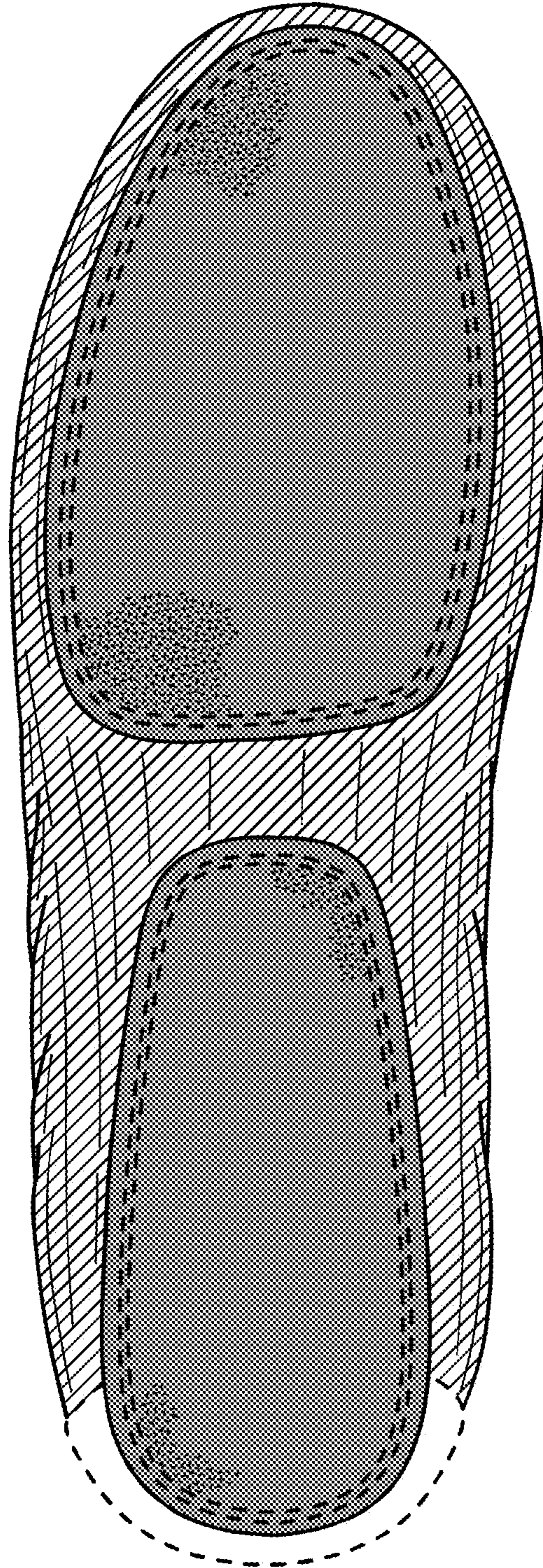

FIG. 68



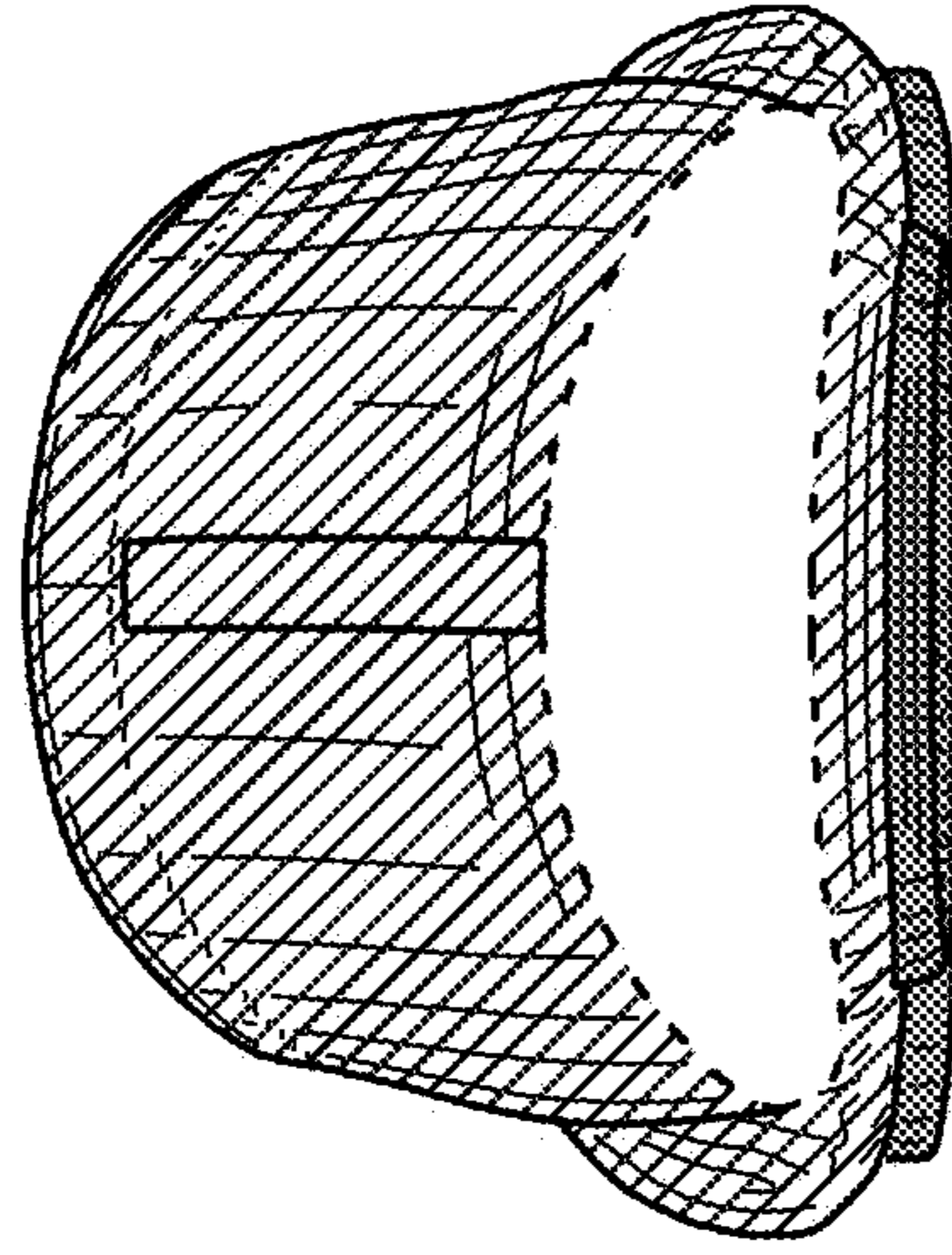

FIG. 70

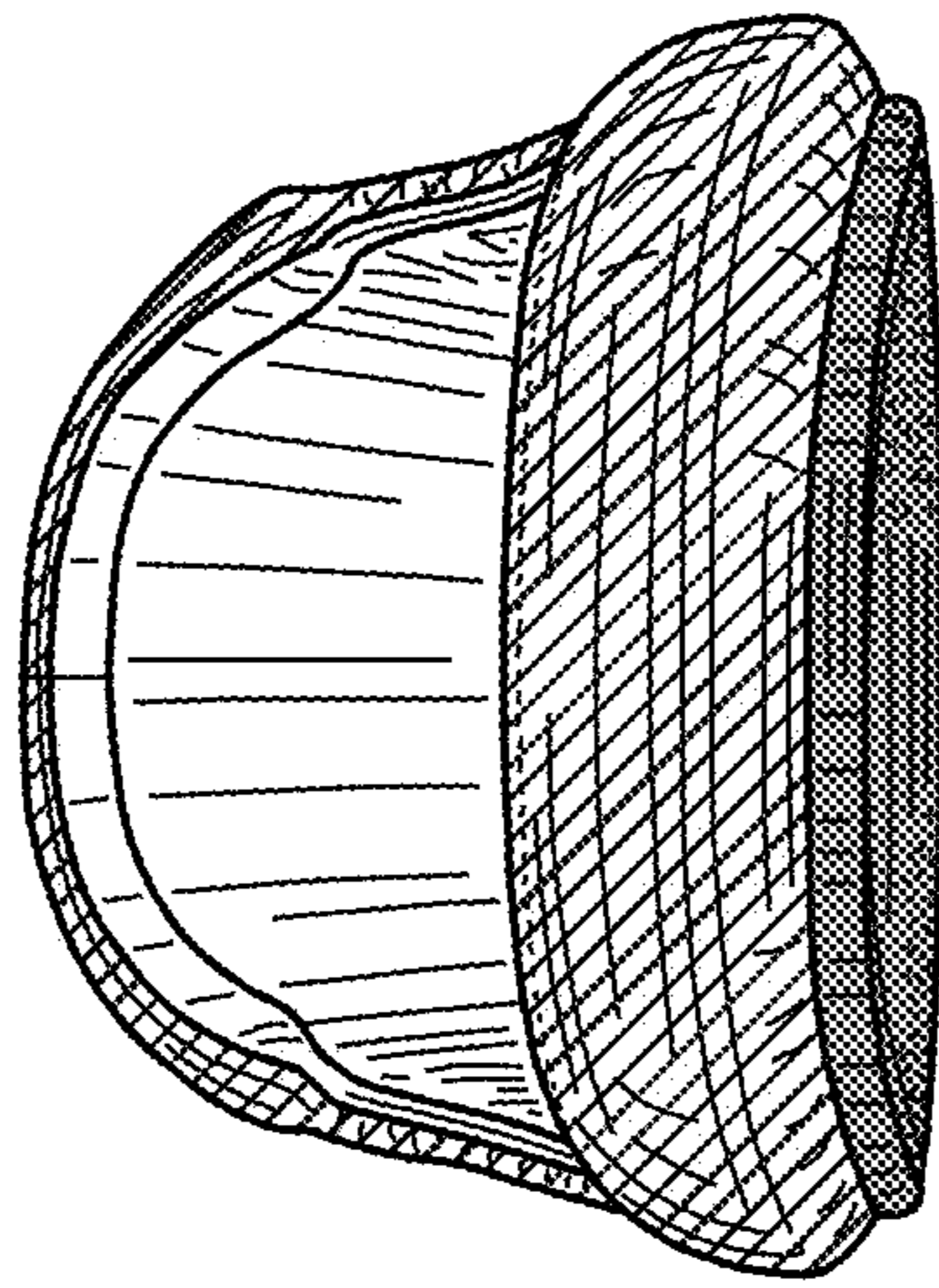

FIG. 69

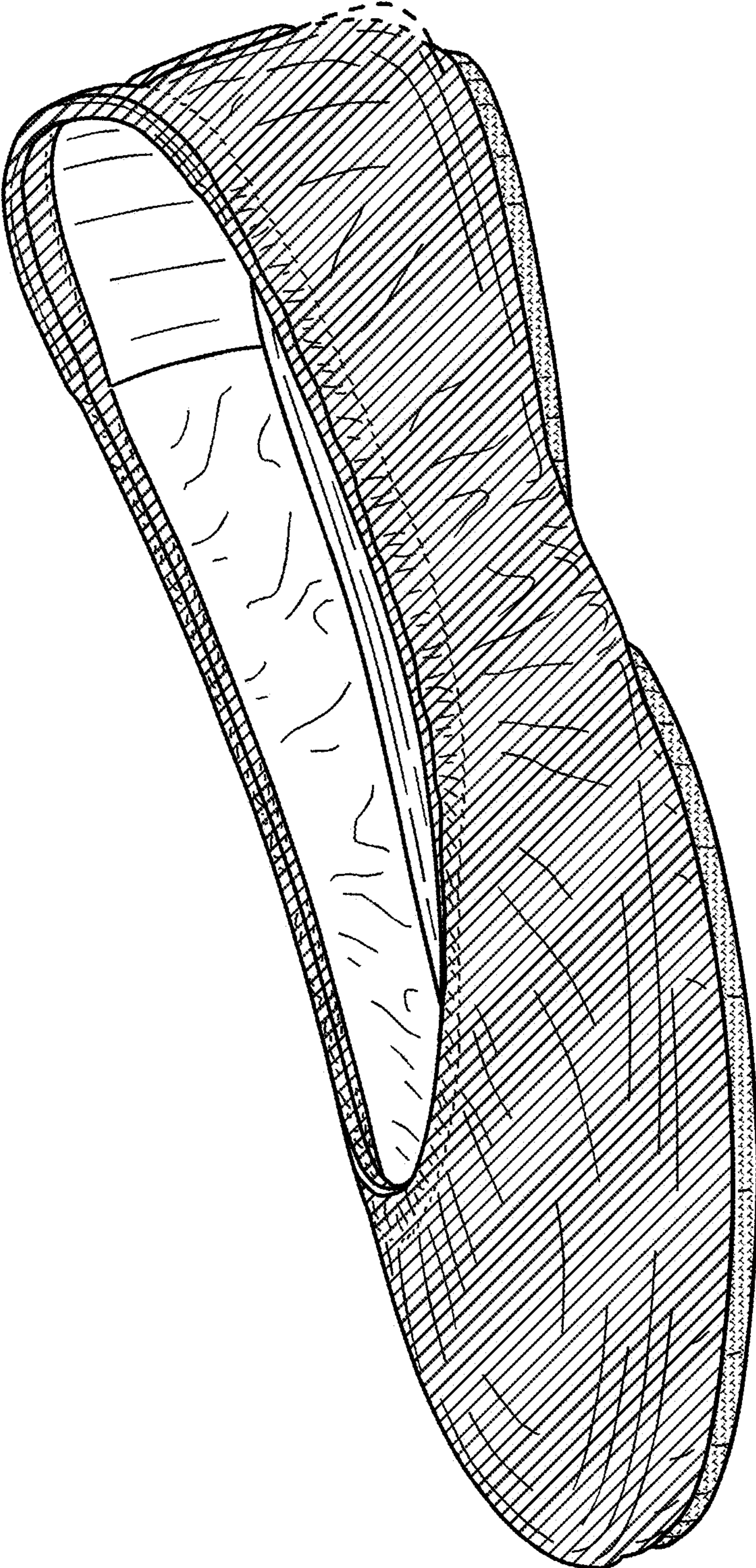

FIG. 71



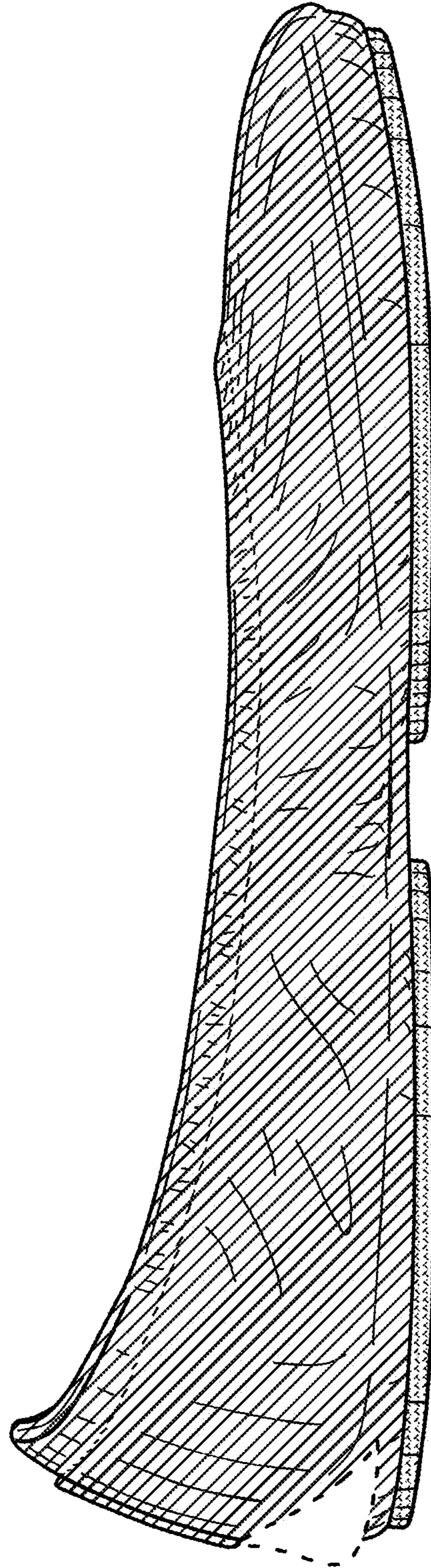

FIG. 72

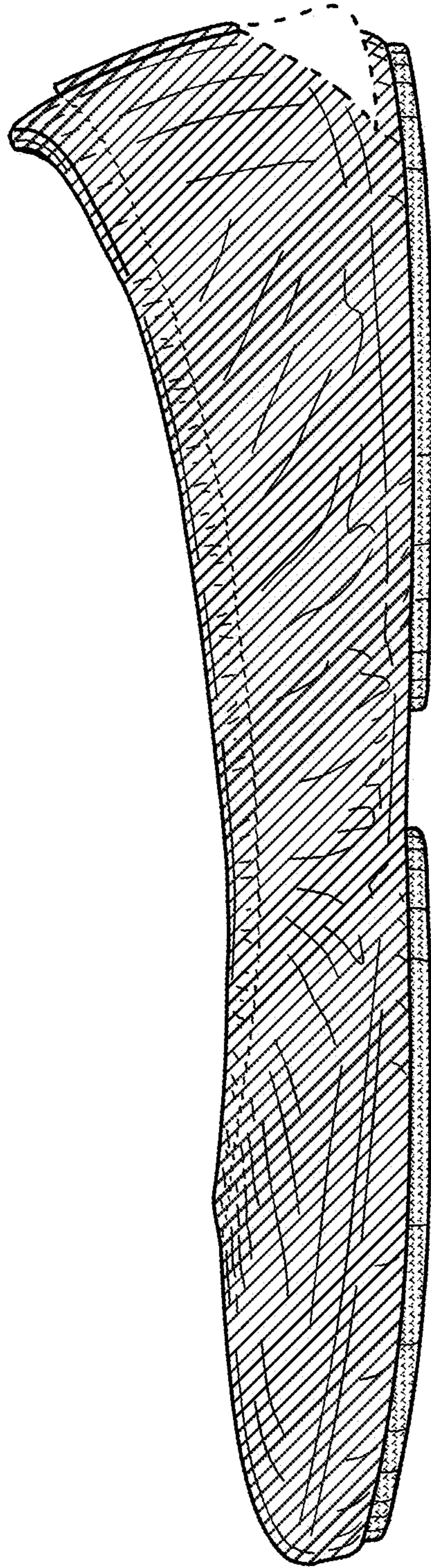

FIG. 73



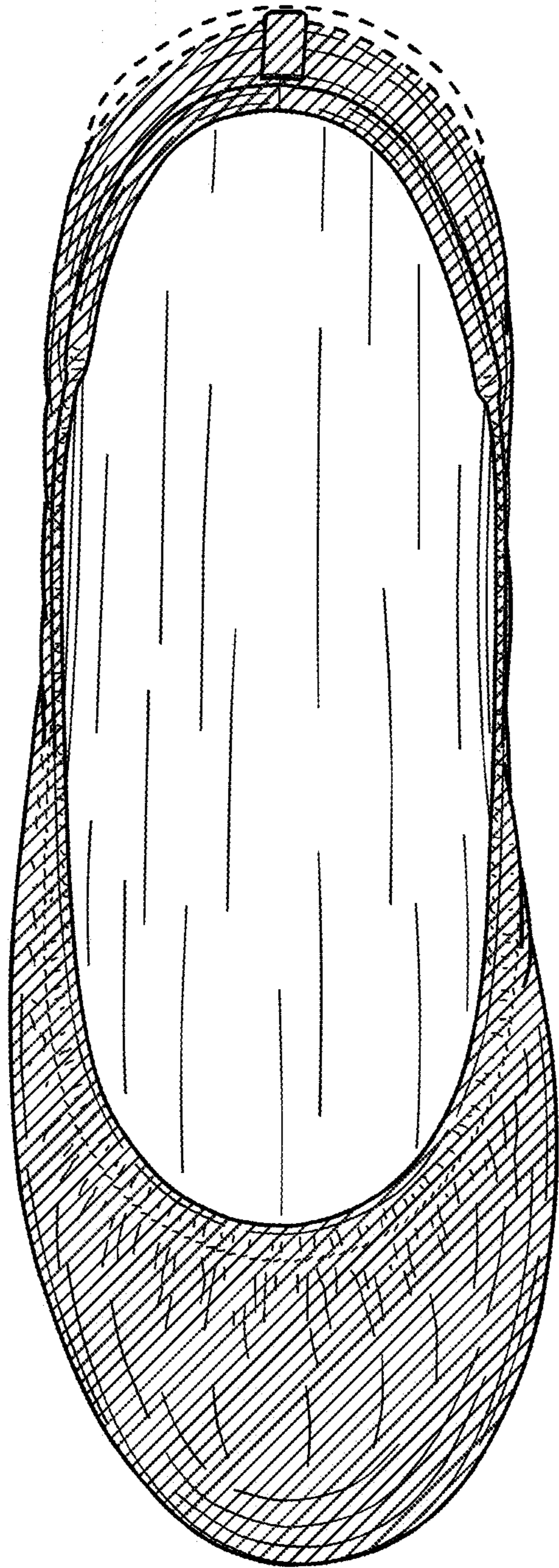

FIG. 74

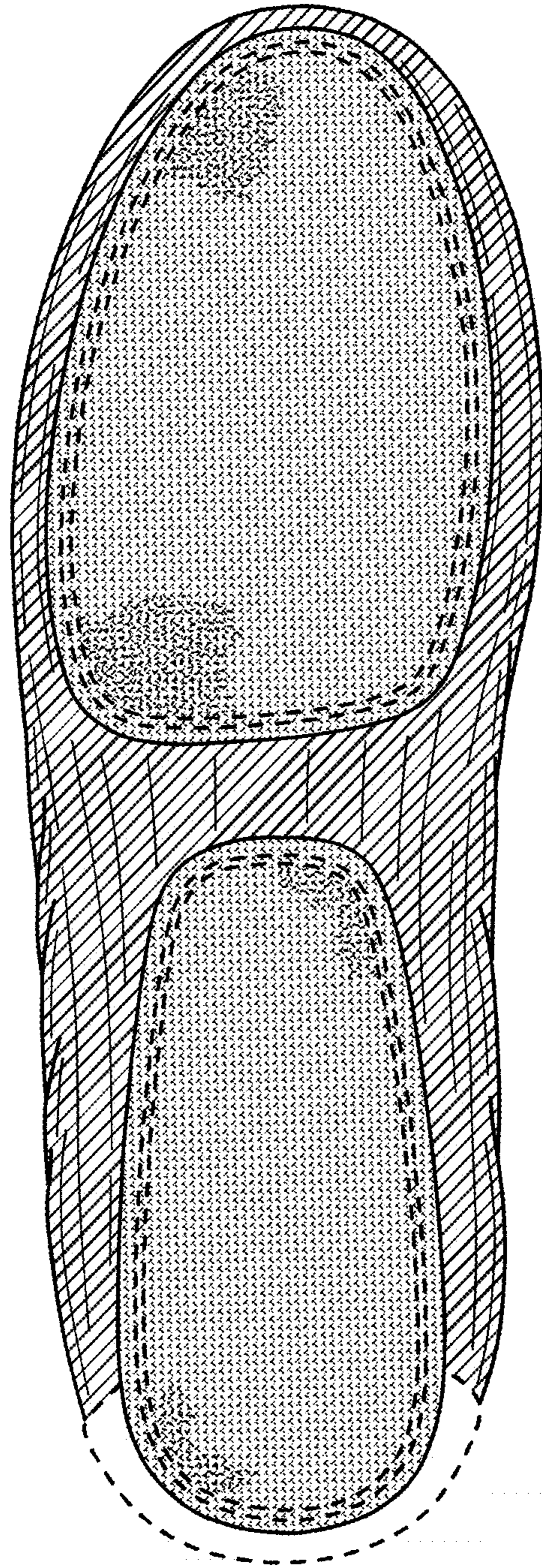

FIG. 75



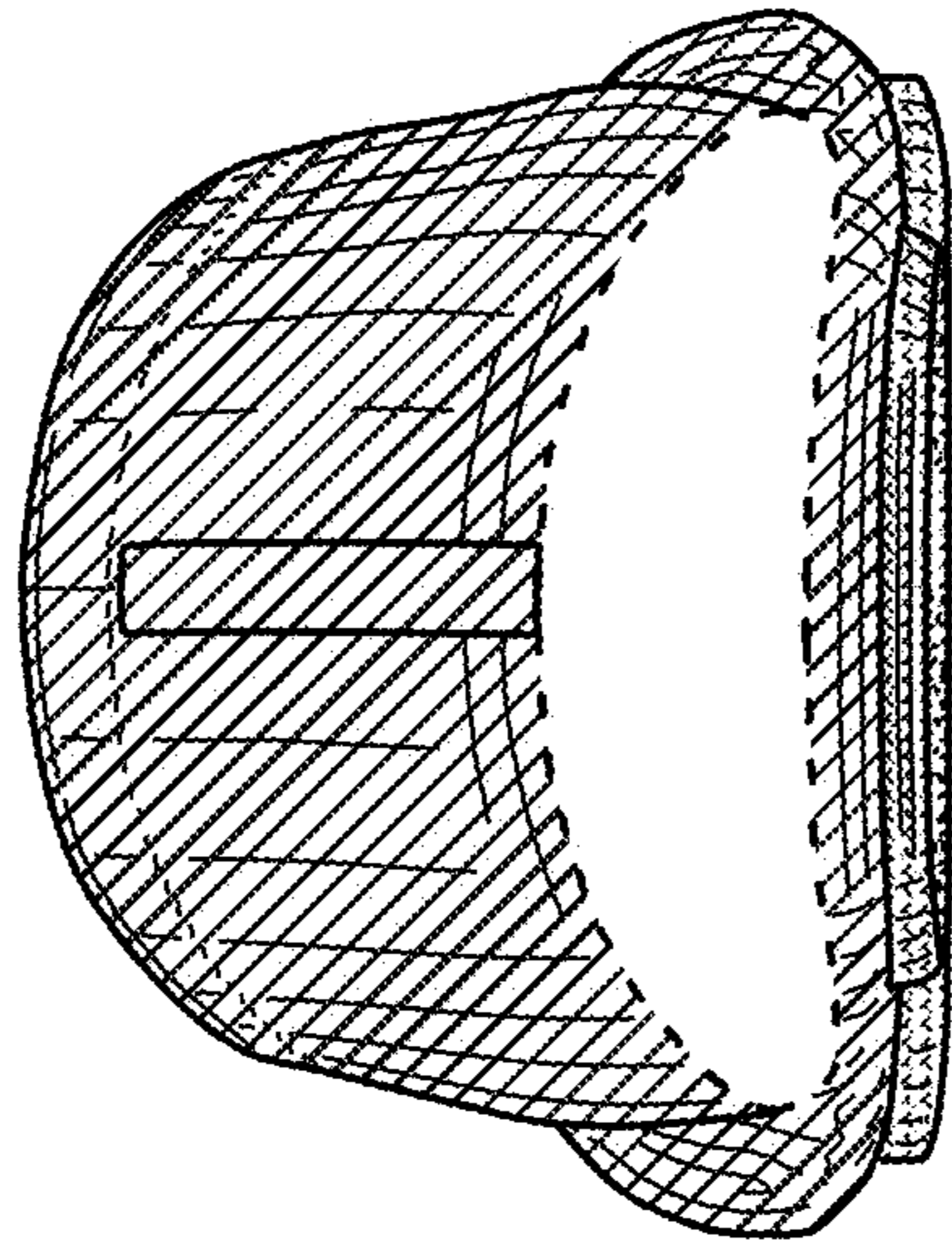

FIG. 77

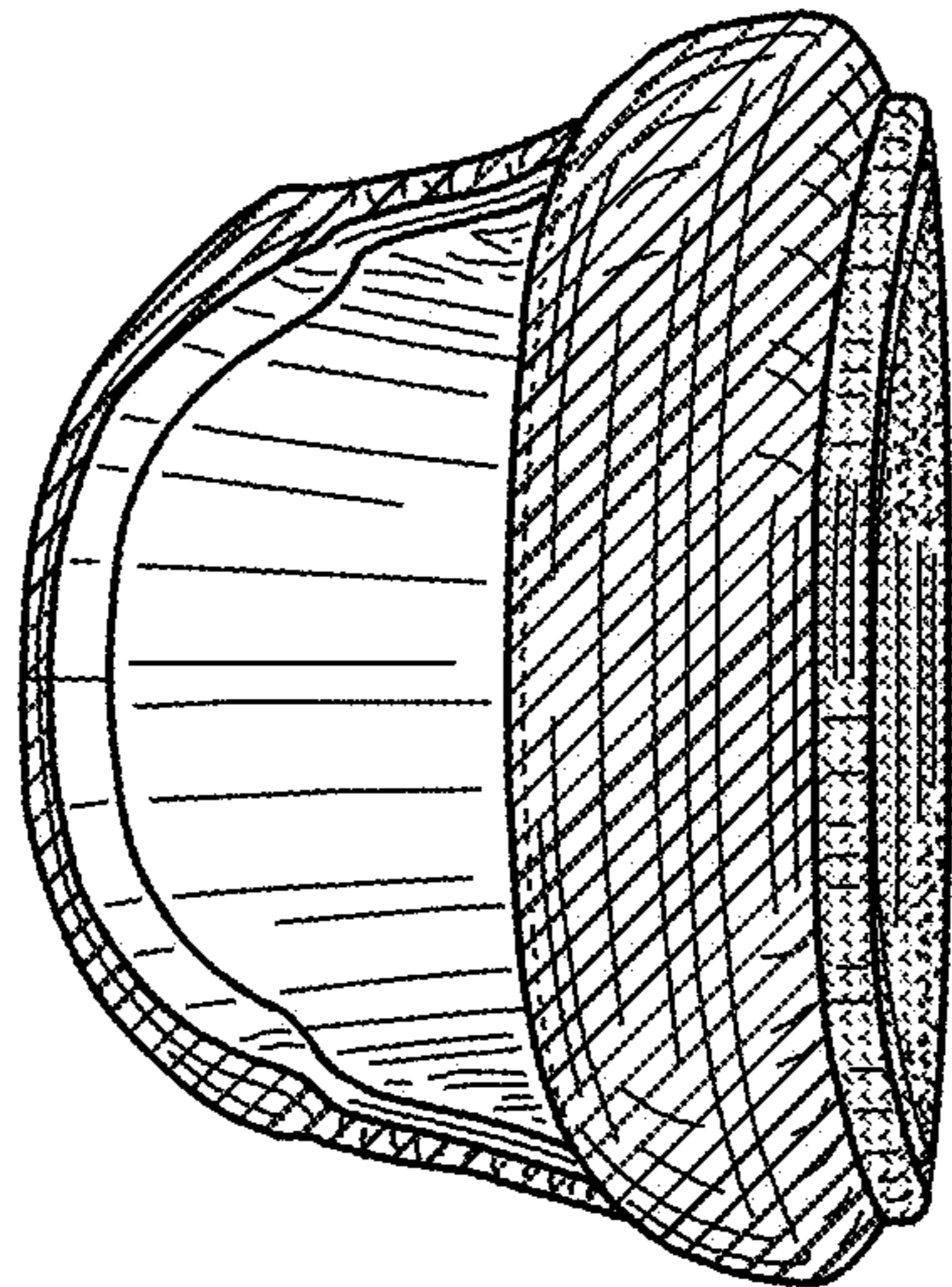

FIG. 76

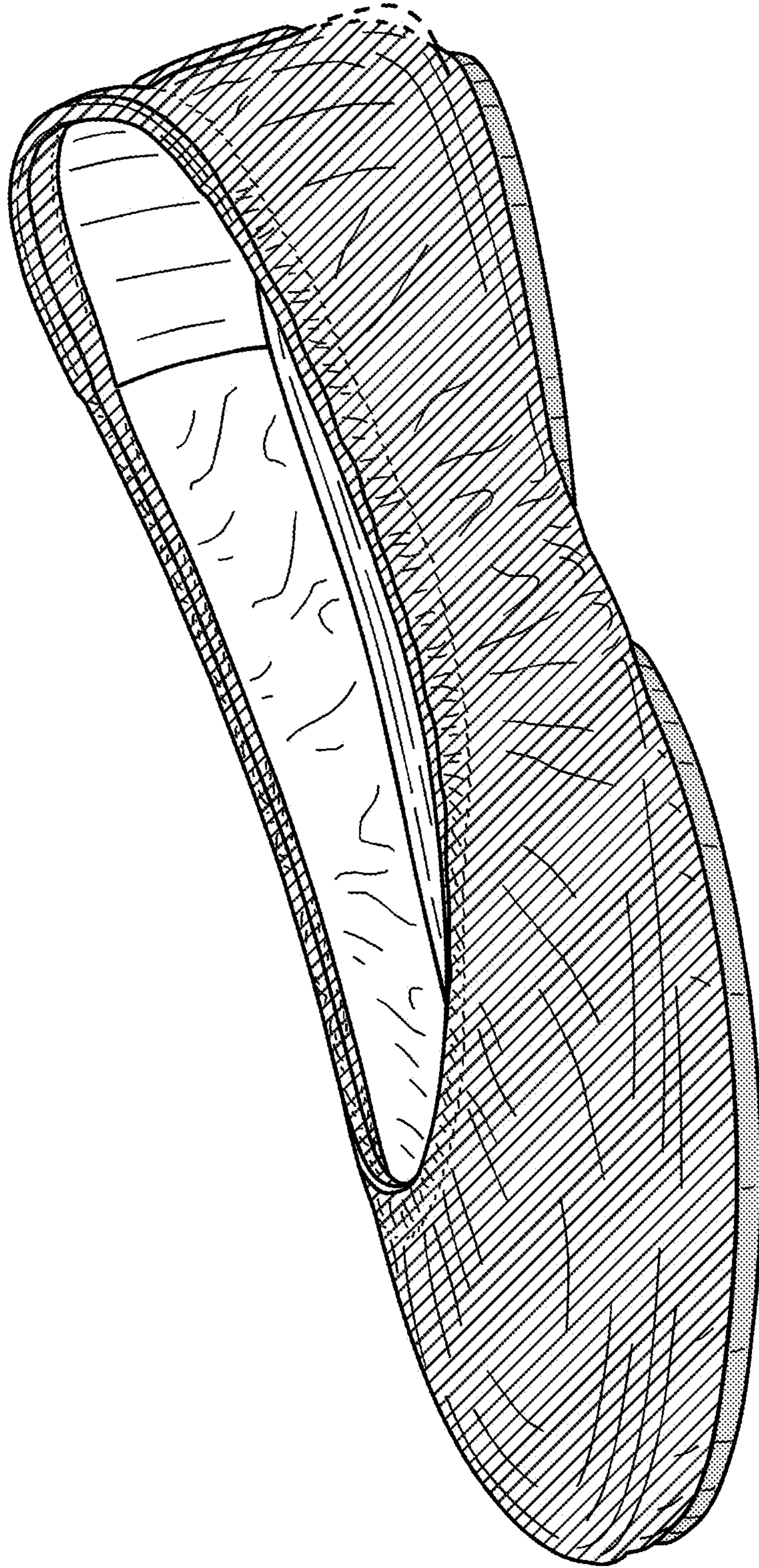

FIG. 78



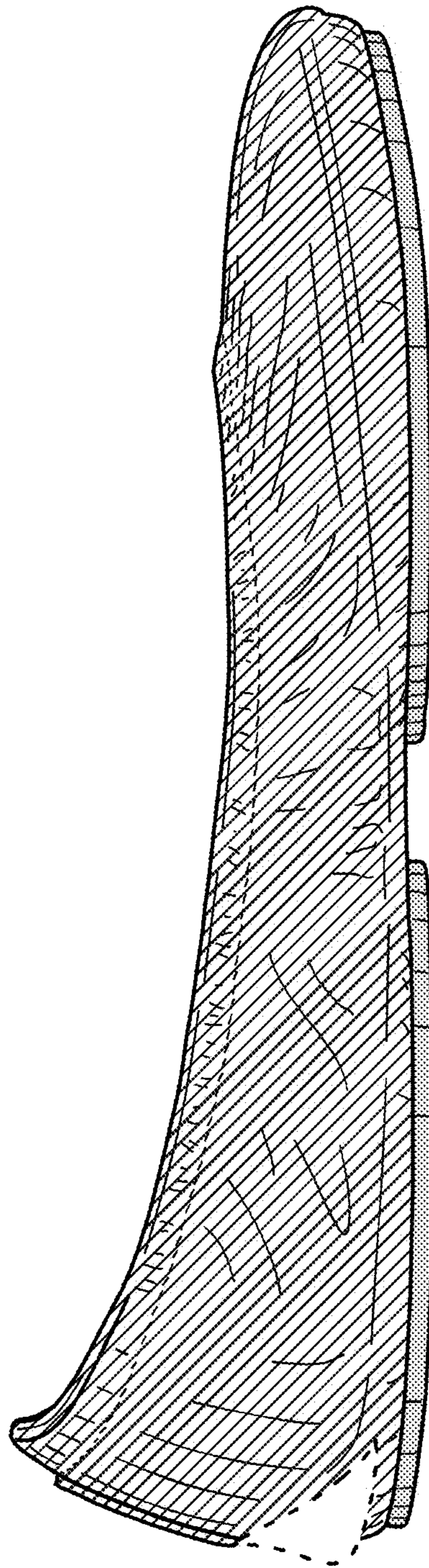

FIG. 79

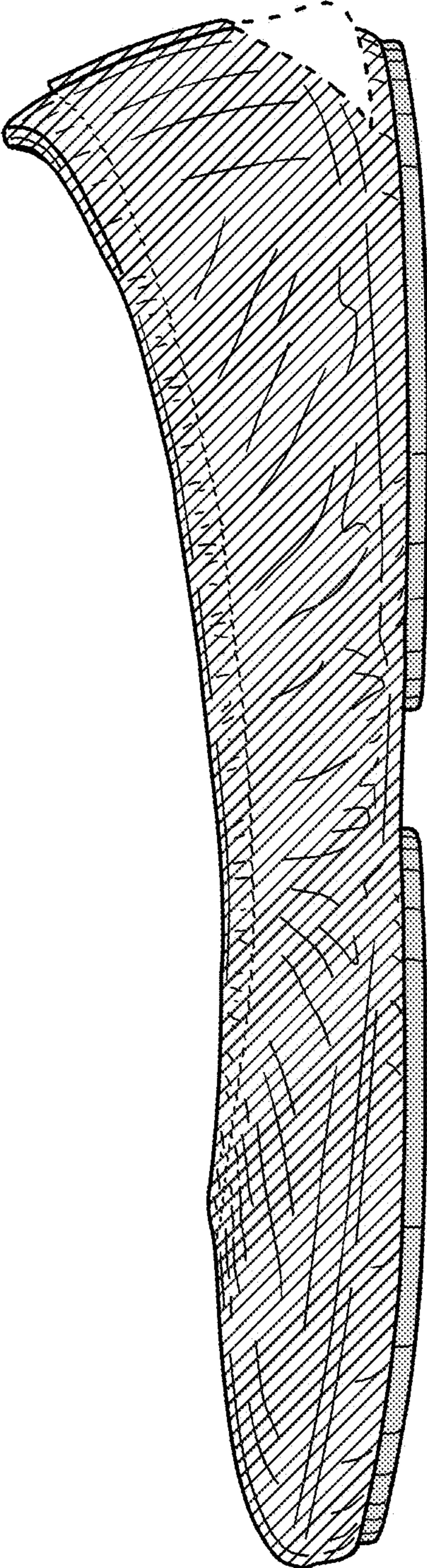

FIG. 80



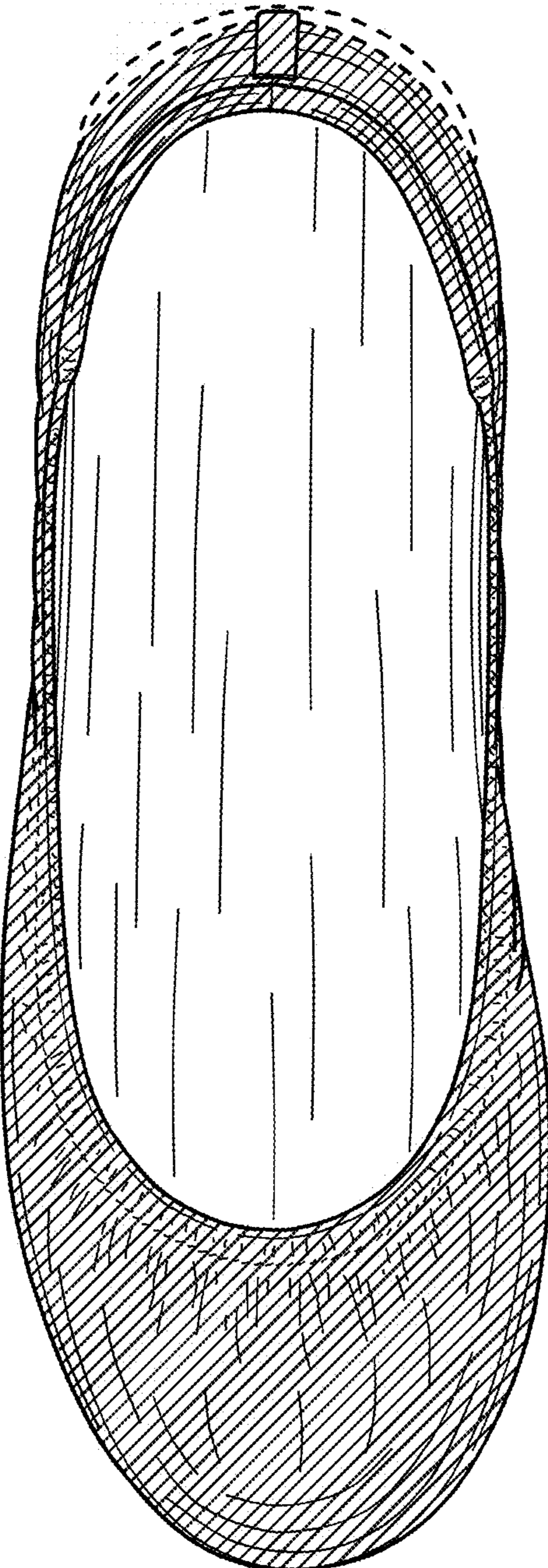

FIG. 81

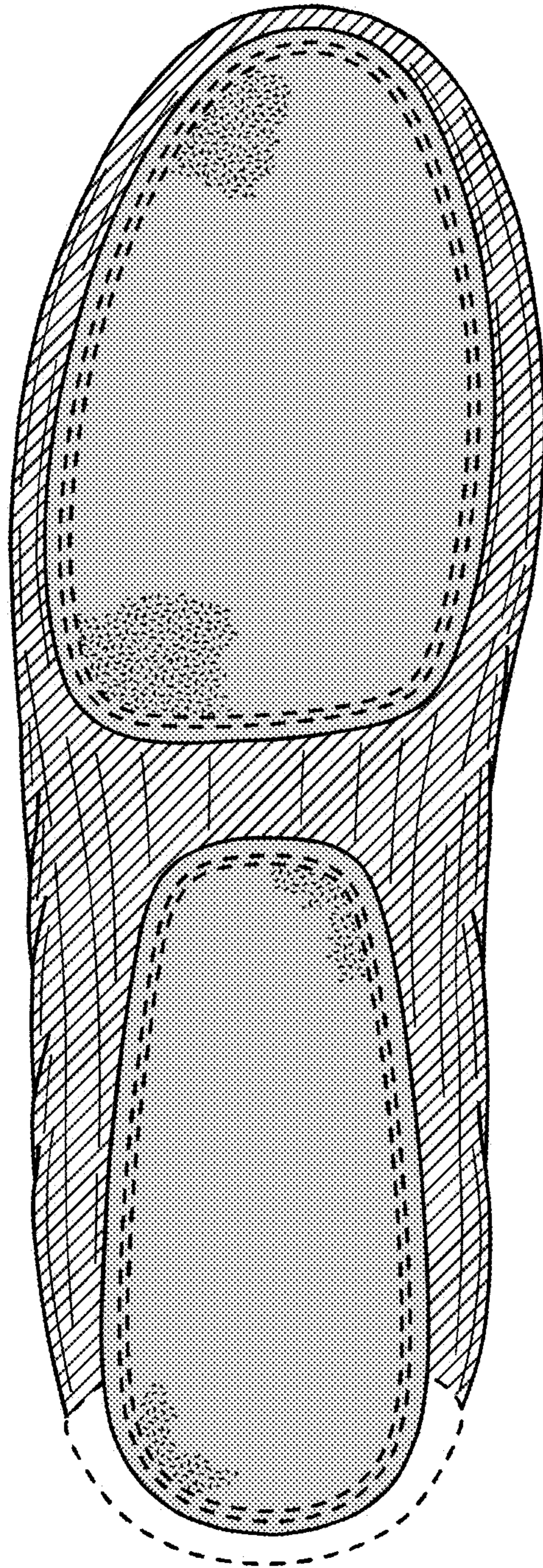

FIG. 82



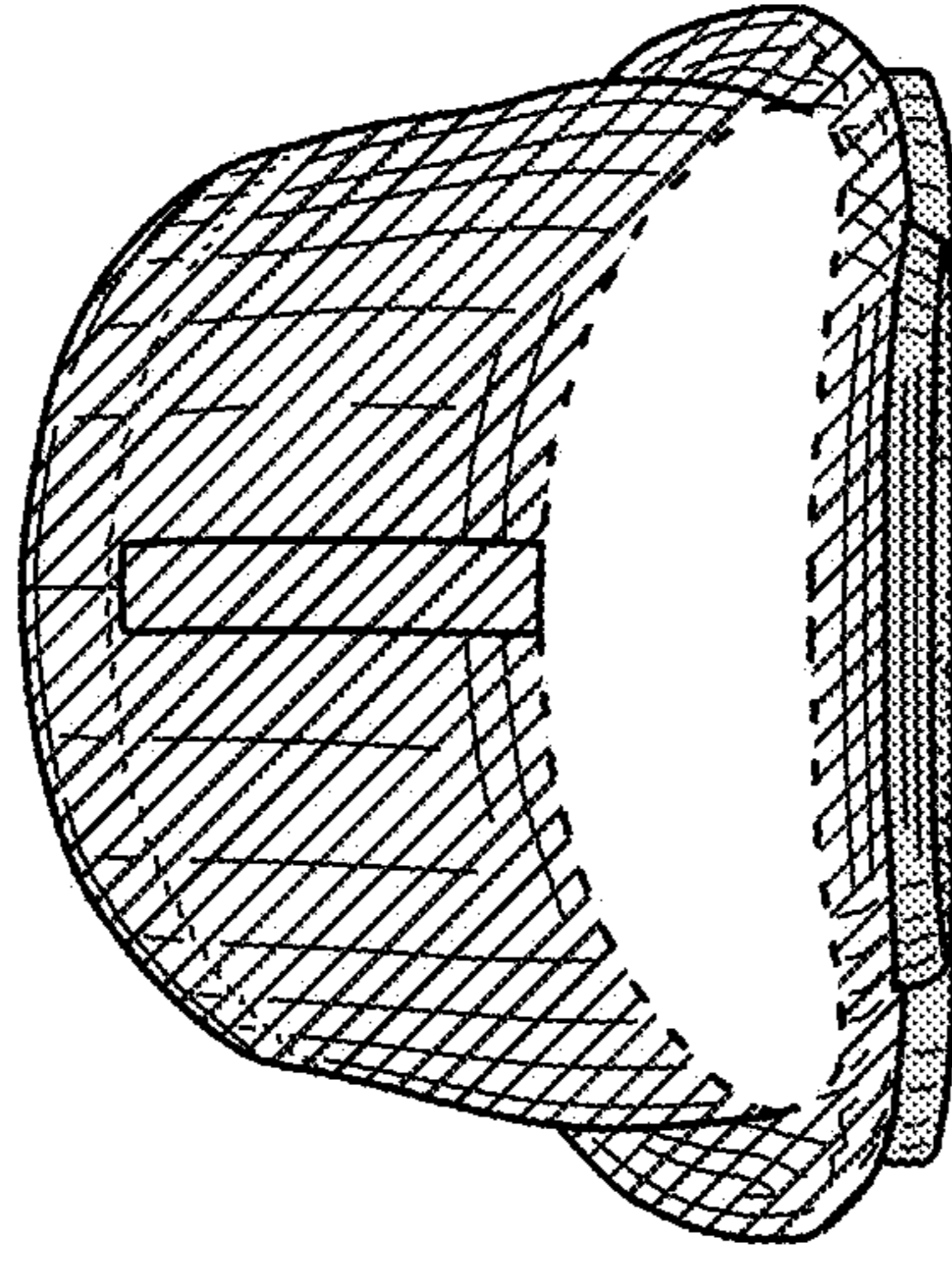

FIG. 84

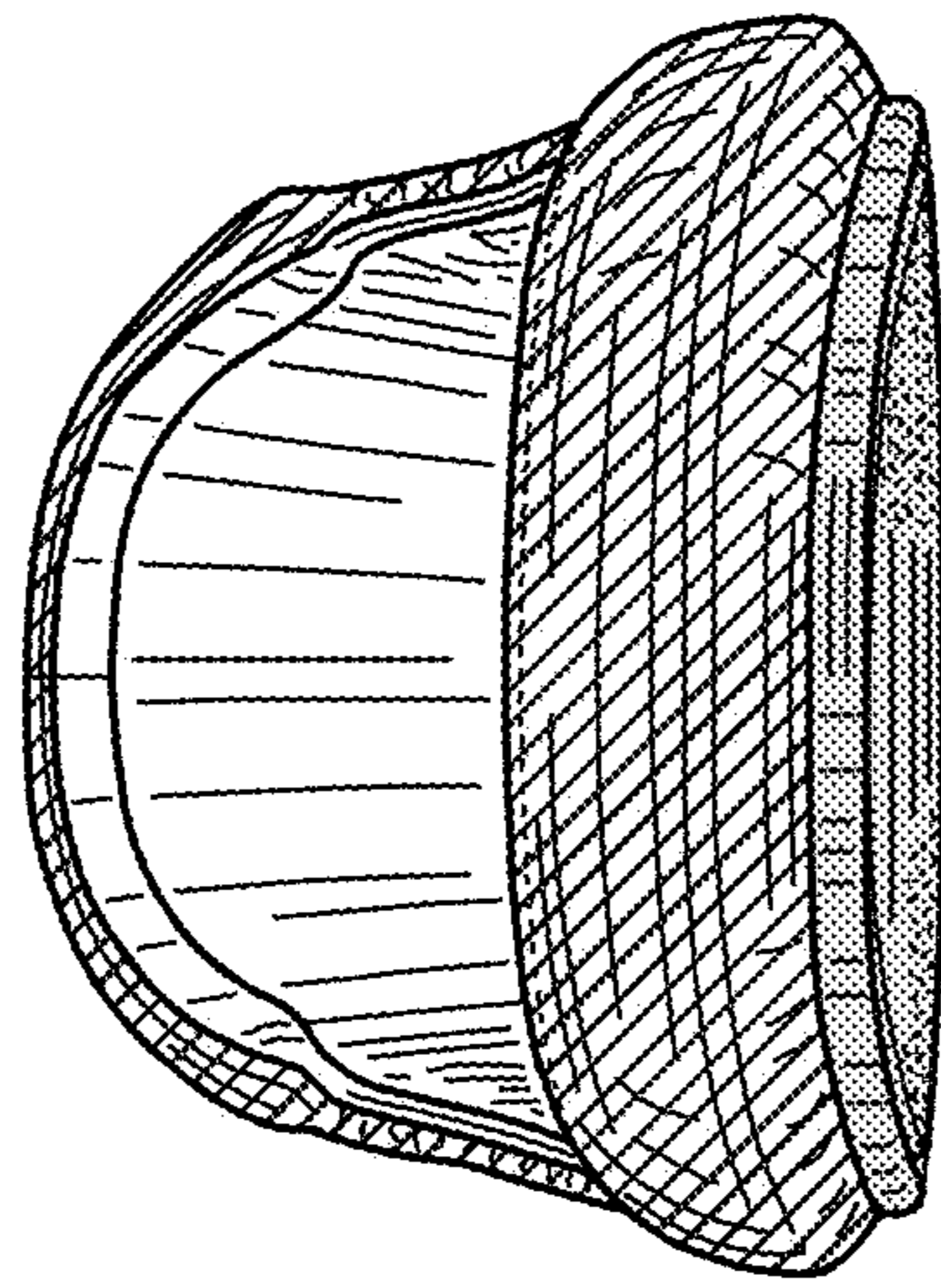

FIG. 83

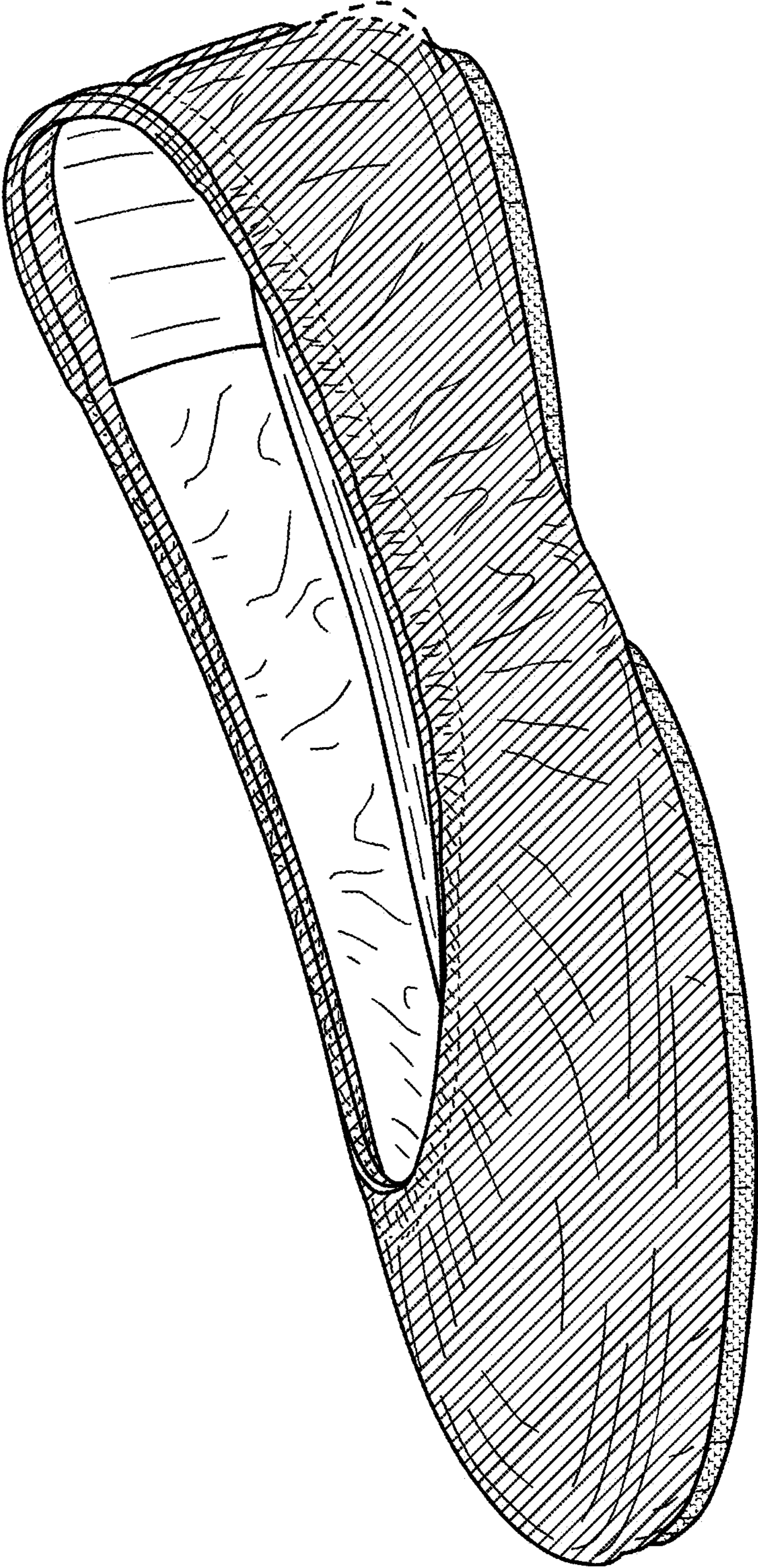

FIG. 85



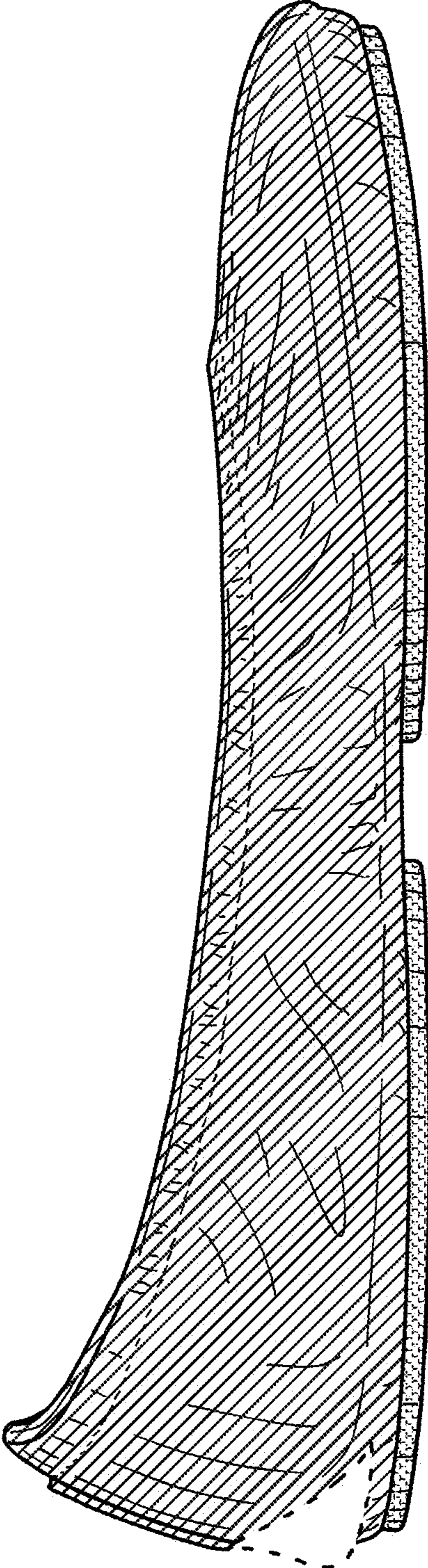

FIG. 86

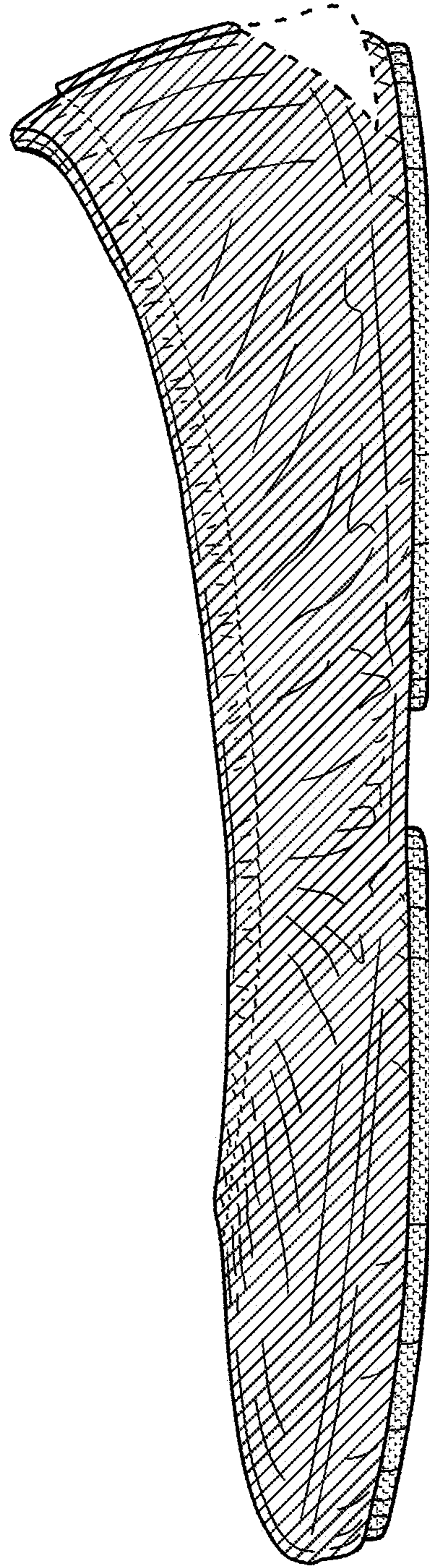

FIG. 87



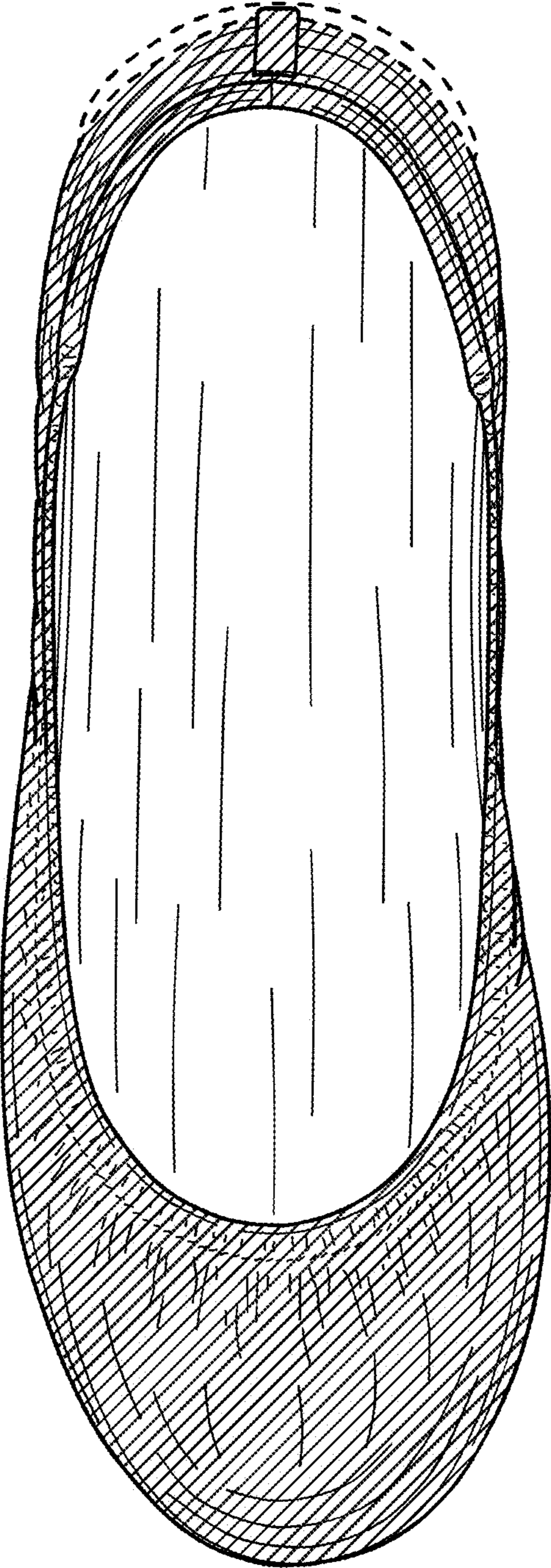

FIG. 88

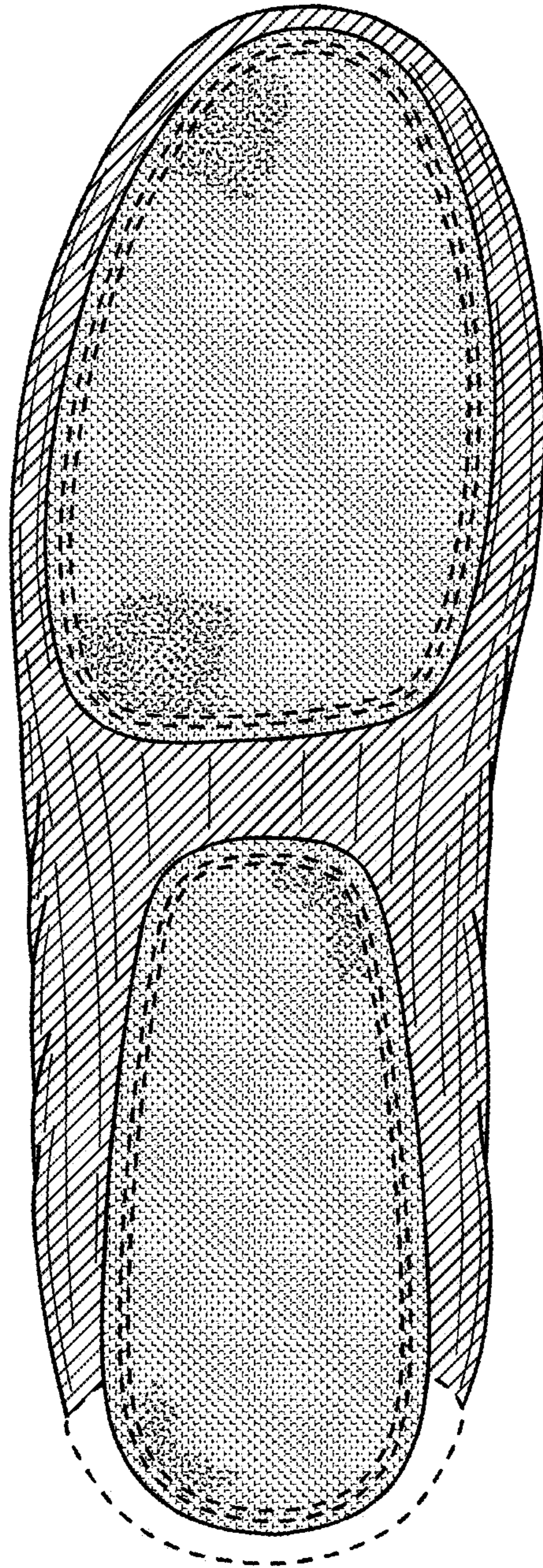

FIG. 89



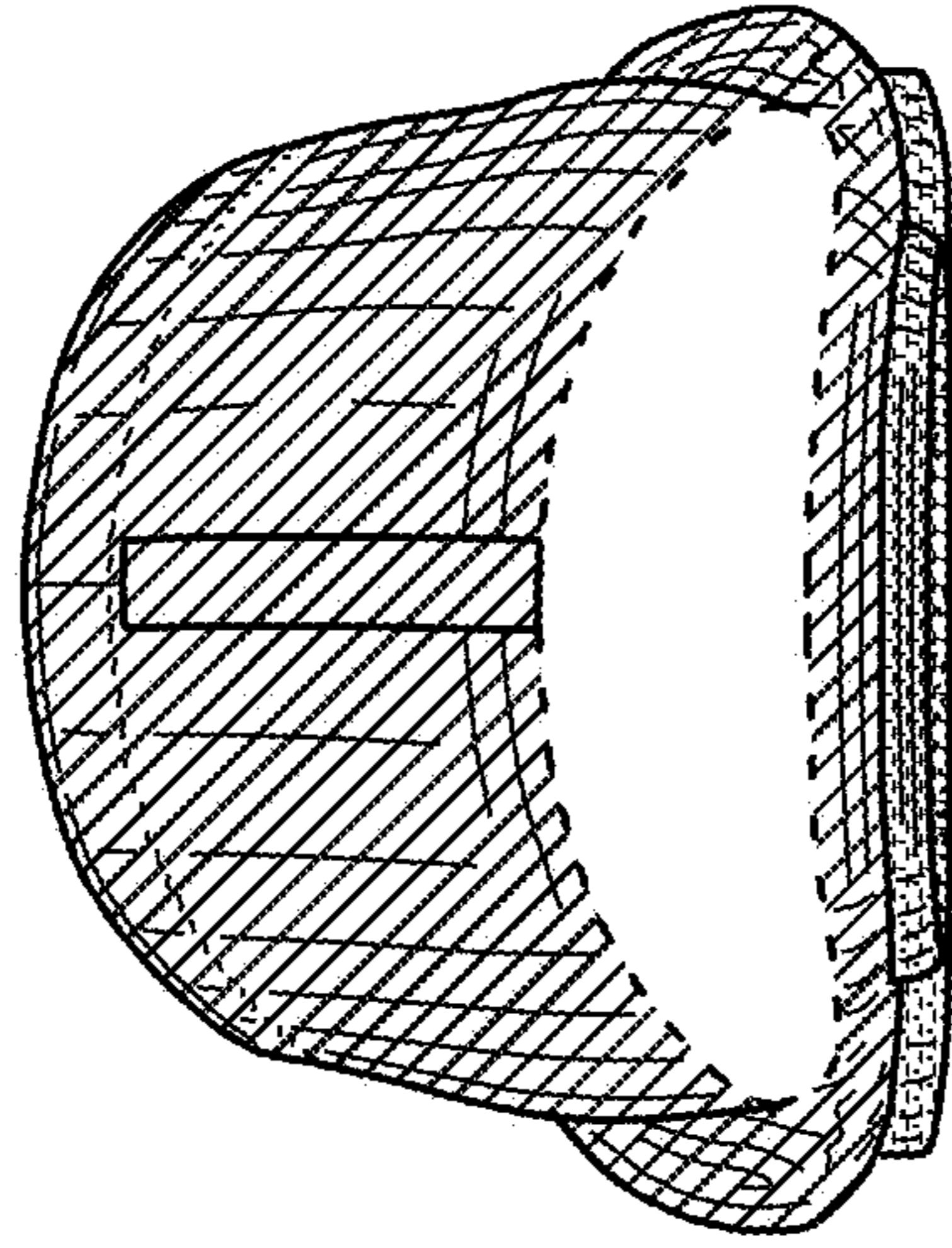

FIG. 91

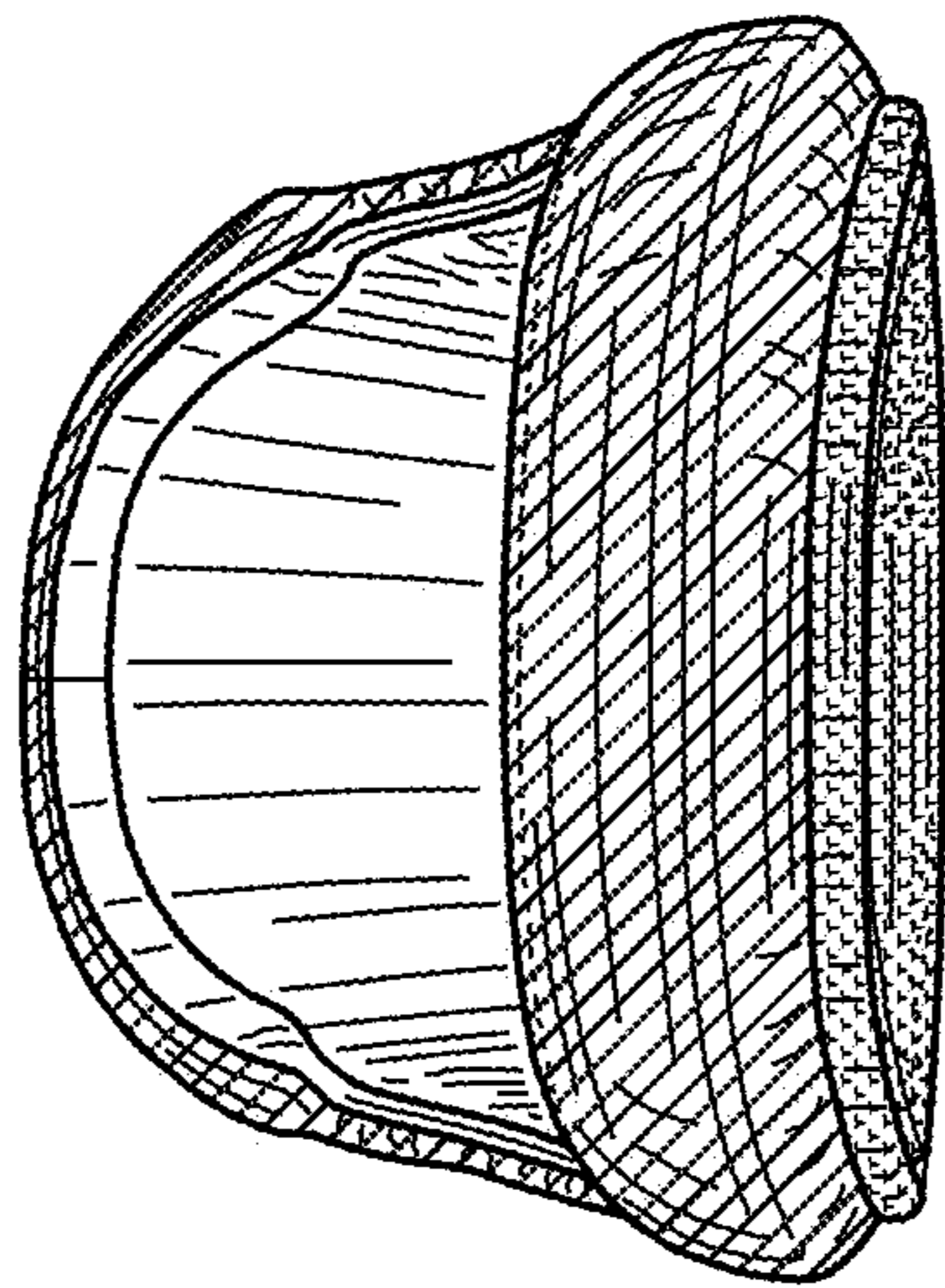

FIG. 90

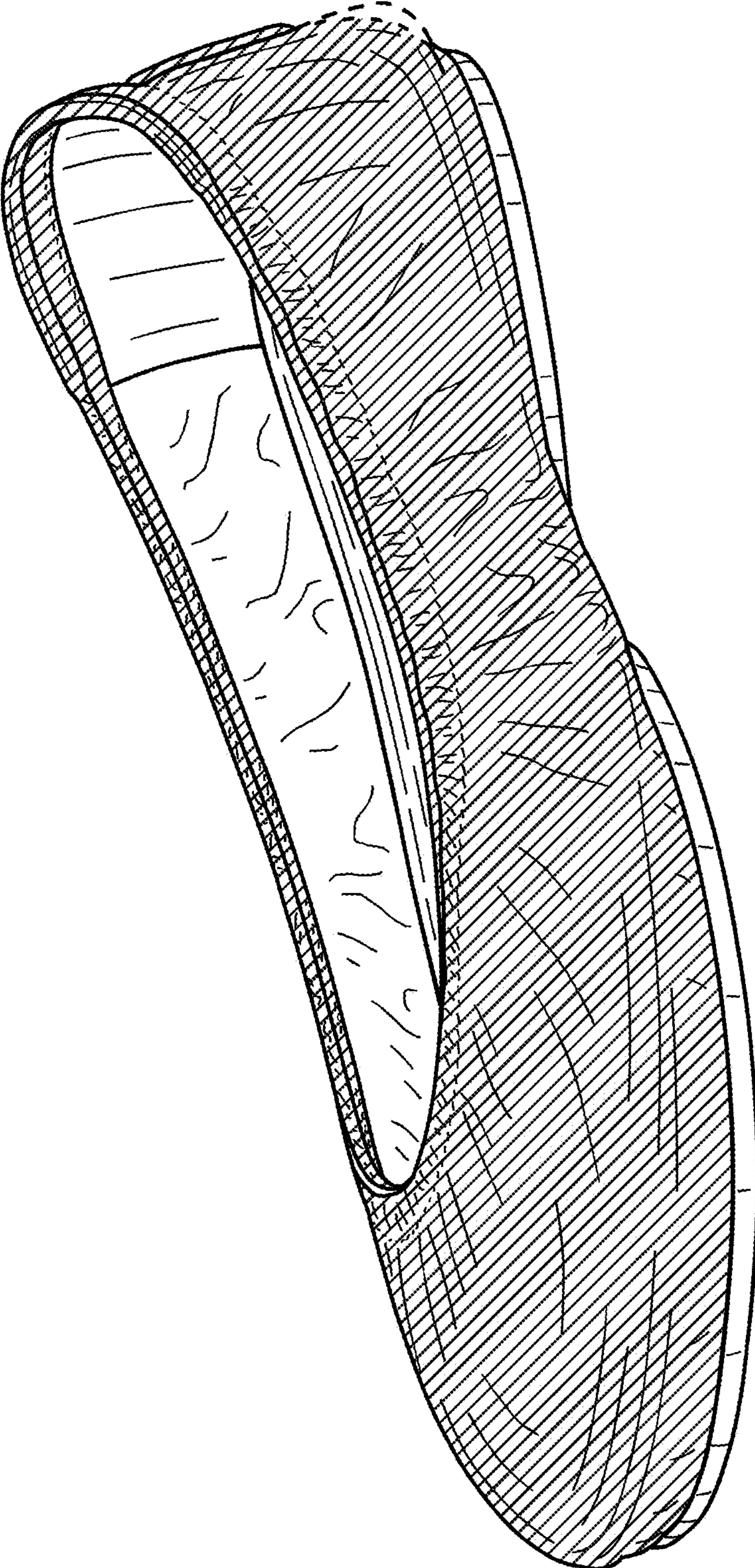

FIG. 92



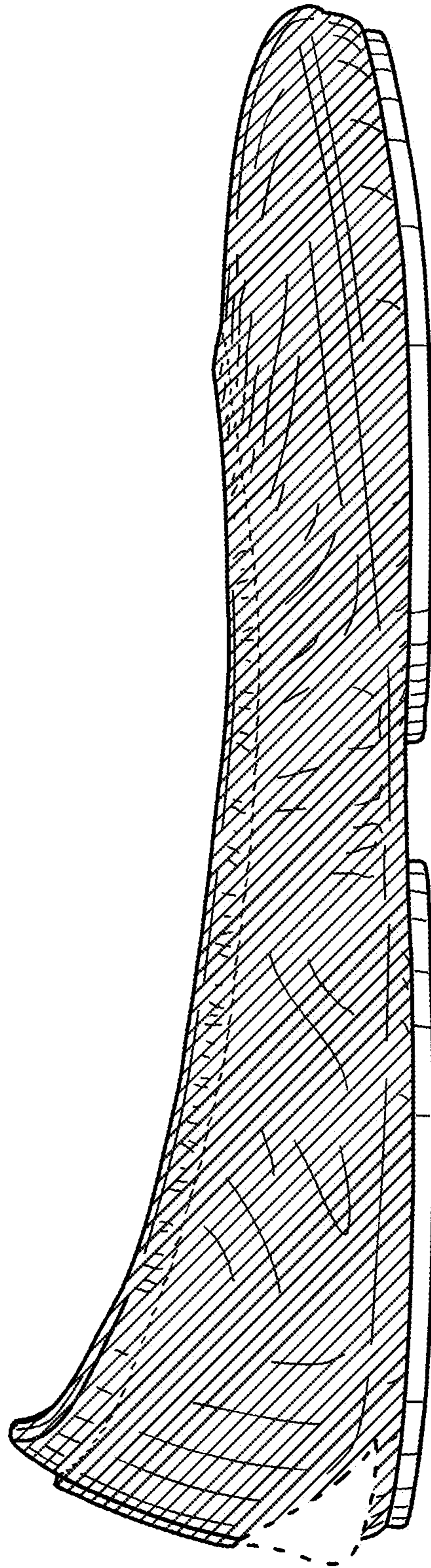

FIG. 93

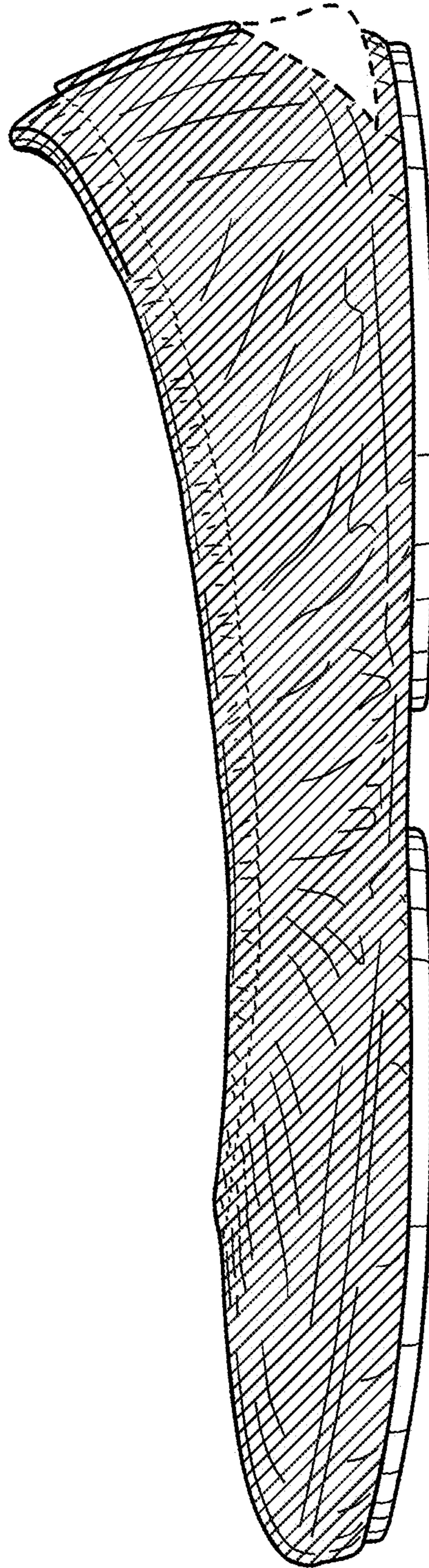

FIG. 94



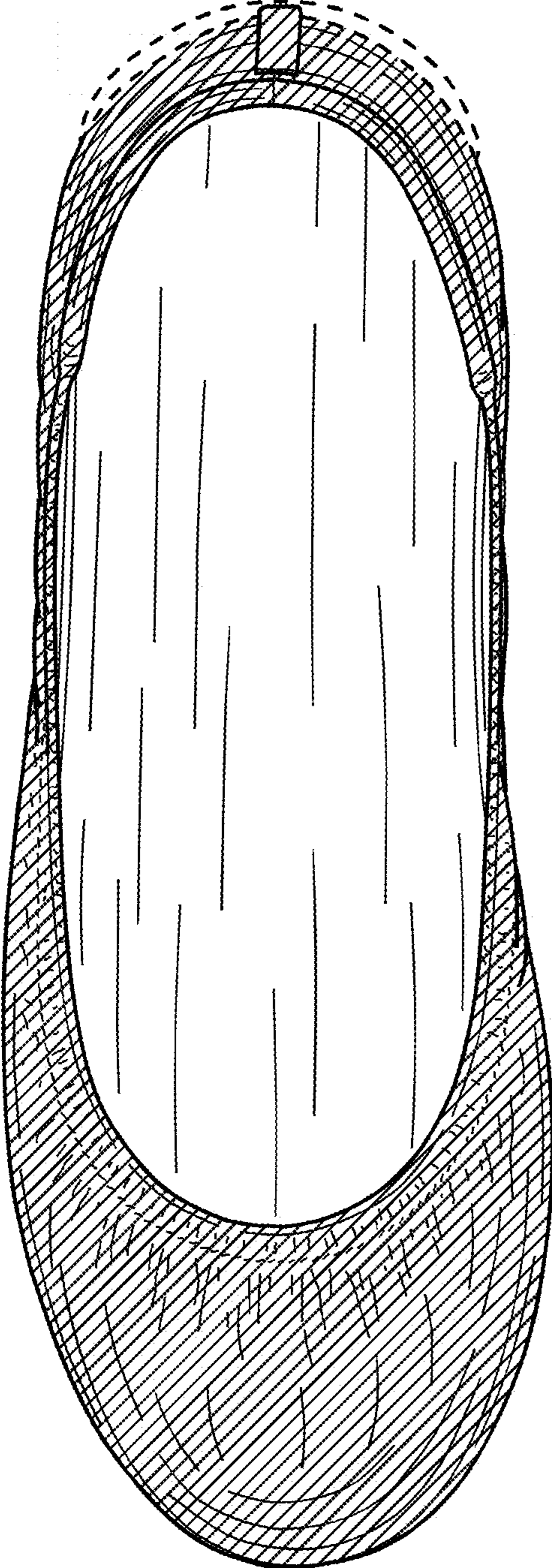

FIG. 95

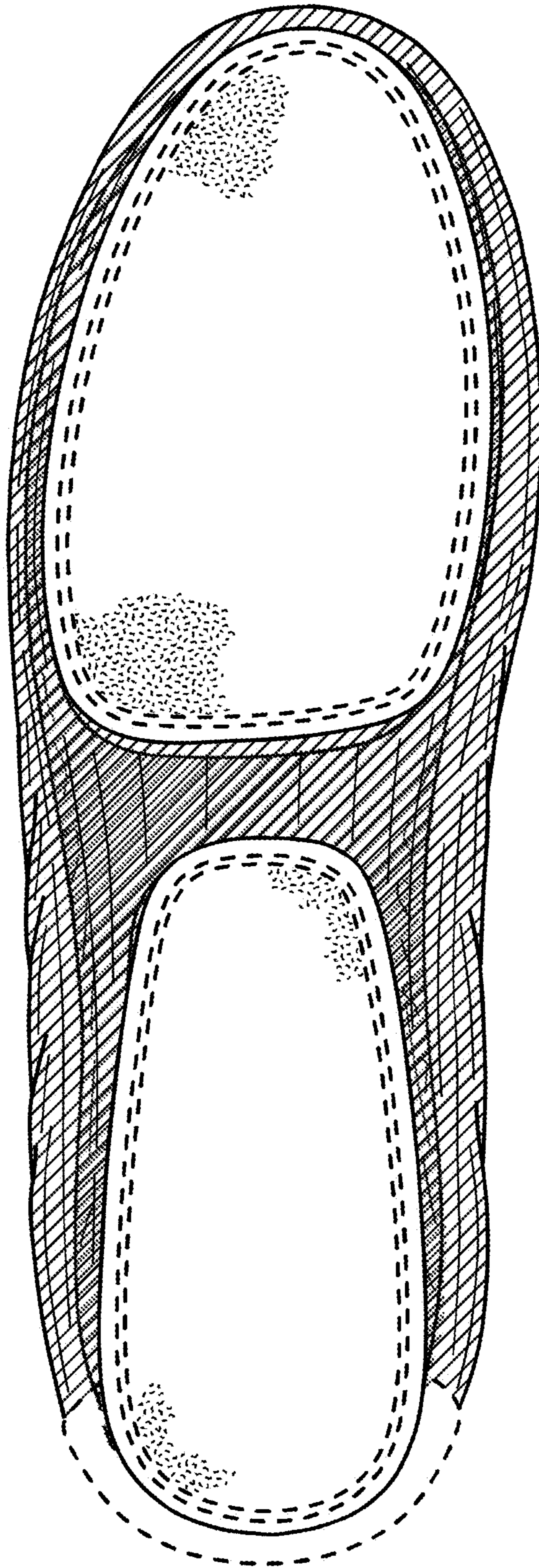

FIG. 96



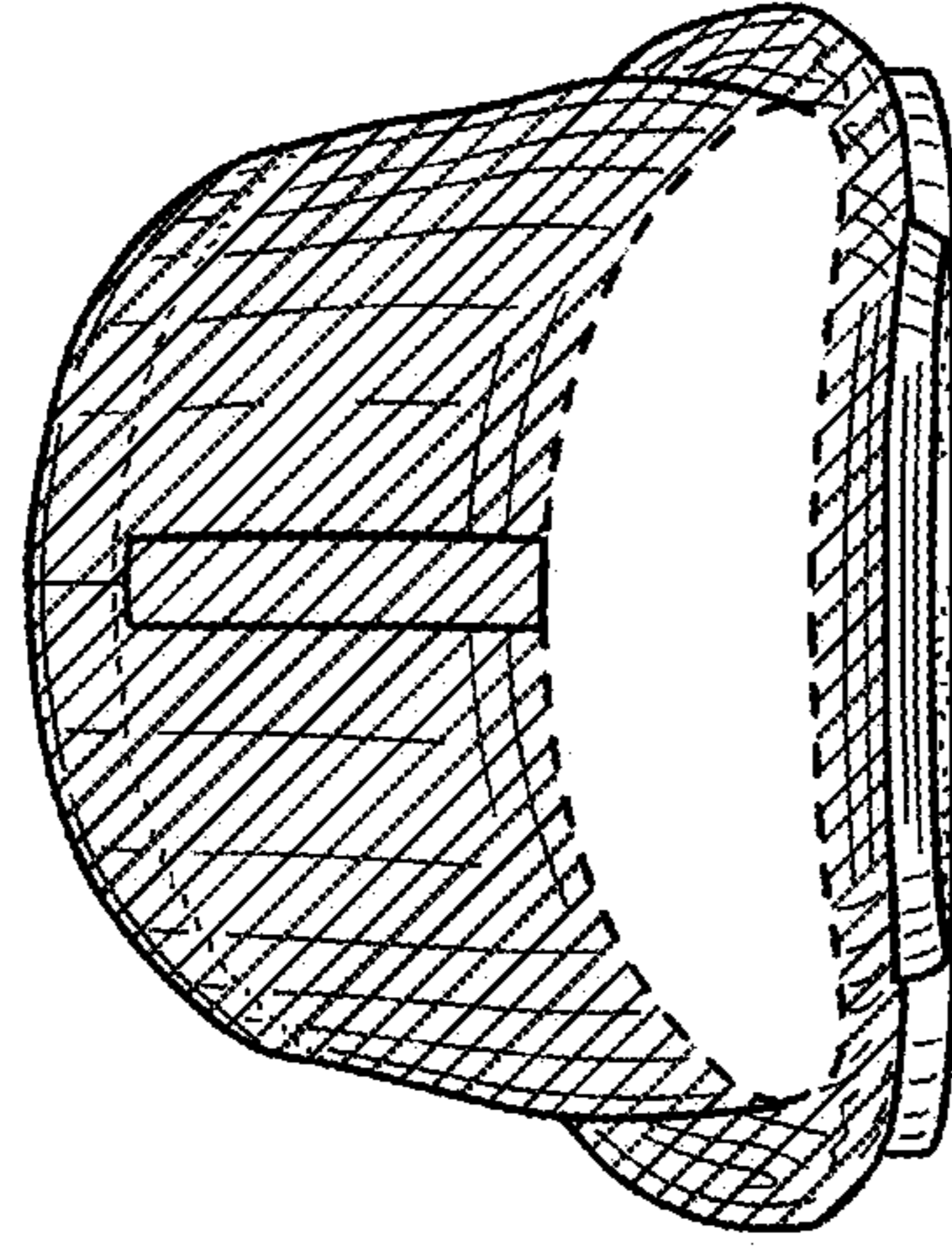

FIG. 98

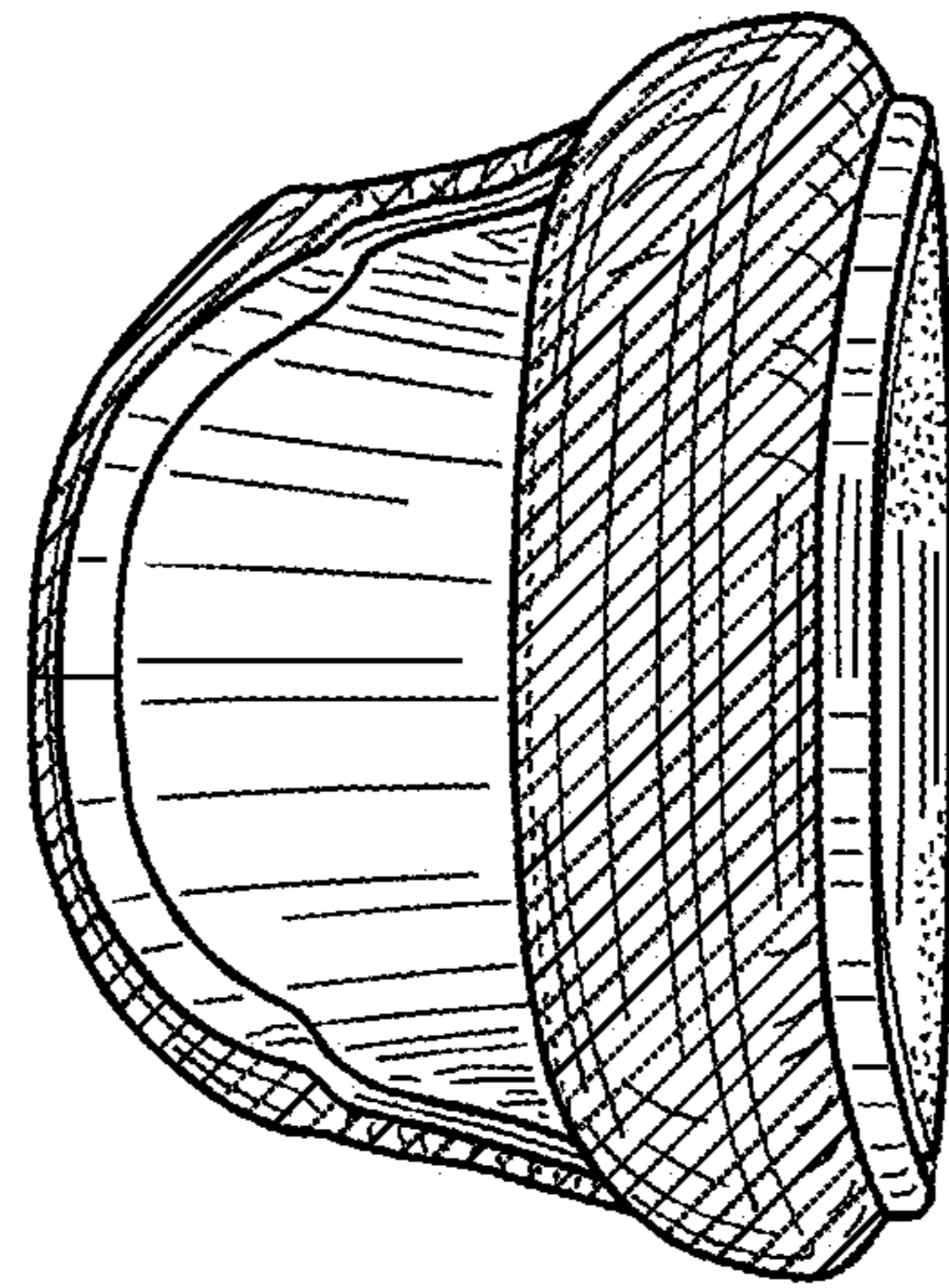

FIG. 97