



US00D945069S

(12) **United States Design Patent**
Shin

(10) **Patent No.:** **US D945,069 S**
(45) **Date of Patent:** **** Mar. 1, 2022**

(54) **RAZOR**
(71) Applicant: **DORCO CO., LTD.**, Seoul (KR)
(72) Inventor: **Seung Mi Shin**, Seoul (KR)
(73) Assignee: **DORCO CO., LTD.**, Seoul (KR)
(**) Term: **15 Years**
(21) Appl. No.: **29/728,465**
(22) Filed: **Mar. 18, 2020**

(30) **Foreign Application Priority Data**
Sep. 18, 2019 (KR) 30-2019-0044737
(51) **LOC (13) Cl.** **28-03**
(52) **U.S. Cl.**
USPC **D28/48**
(58) **Field of Classification Search**
USPC D28/46-48
CPC ... B26B 21/00; B26B 21/08; B26B 21/14-18;
B26B 21/185-227; B26B 21/40; B26B
21/4062-4075; B26B 21/44-48; B26B
21/30-32; B26B 21/50-528
See application file for complete search history.

(56) **References Cited**
U.S. PATENT DOCUMENTS
D616,607 S * 5/2010 Ramm D28/48
D745,215 S * 12/2015 Go D28/48

D768,929 S * 10/2016 Go D28/48
D789,609 S * 6/2017 Kong D28/48
D822,901 S * 7/2018 Shin D28/48
D824,102 S * 7/2018 Go D28/48
D827,201 S * 8/2018 Go D28/48
D878,678 S * 3/2020 Psimadas D28/48
D879,375 S * 3/2020 Go D28/48
D886,382 S * 6/2020 Dubin D28/48
D899,689 S * 10/2020 Kong D28/48
2010/0313425 A1 * 12/2010 Hawes A45D 26/00
30/44
2013/0291390 A1 * 11/2013 Gajria B26B 21/52
30/526
2018/0370052 A1 * 12/2018 Zarembo B26B 21/521

* cited by examiner

Primary Examiner — Jennifer Rivard
(74) *Attorney, Agent, or Firm* — NSIP Law

(57) **CLAIM**
The ornamental design for a razor, as shown and described.

DESCRIPTION
FIG. 1 is a perspective view of a razor showing the new design;
FIG. 2 is a front view thereof;
FIG. 3 is a rear view thereof;
FIG. 4 is a left-side view thereof; a right-side view is mirror image with the left side view thereof;
FIG. 5 is a top view thereof; and,
FIG. 6 is a bottom view thereof.
The broken lines illustrate portions of the razor that form no part of the claimed design.

1 Claim, 6 Drawing Sheets

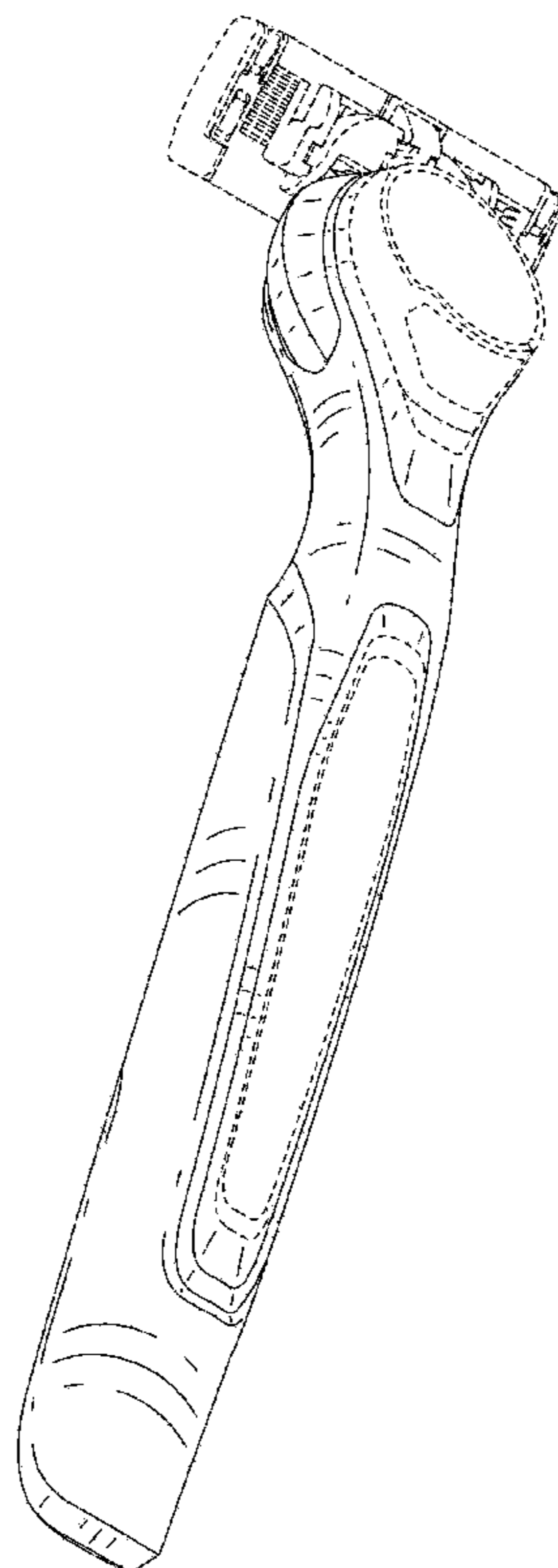

FIG. 1

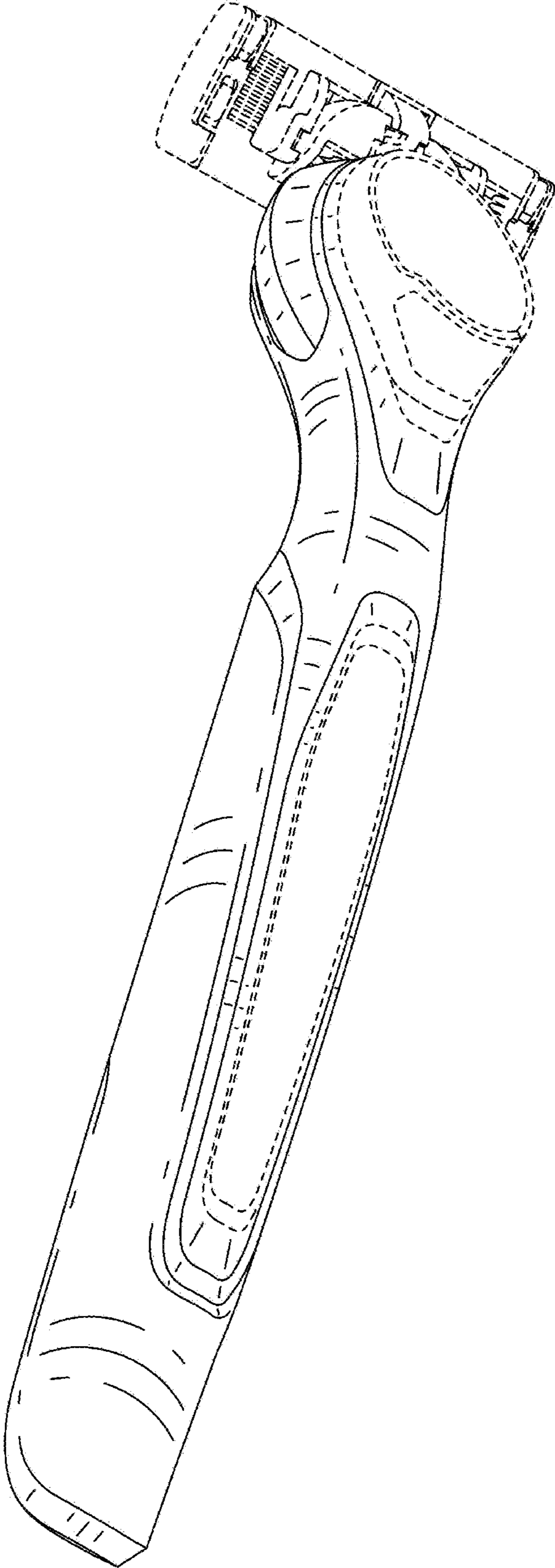

FIG. 2

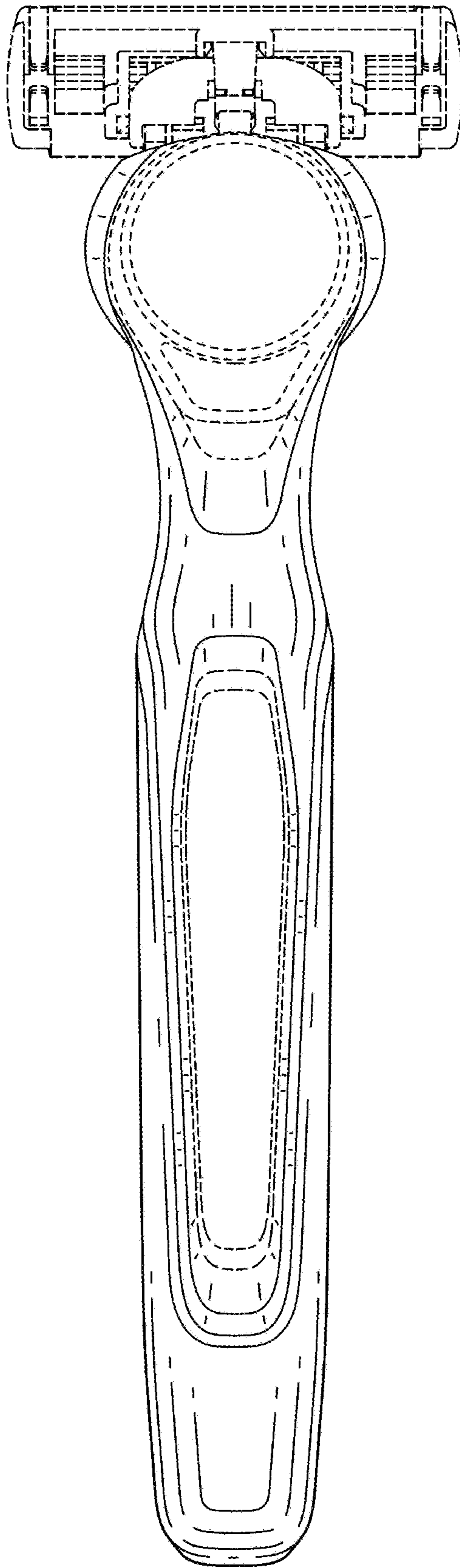

FIG. 3

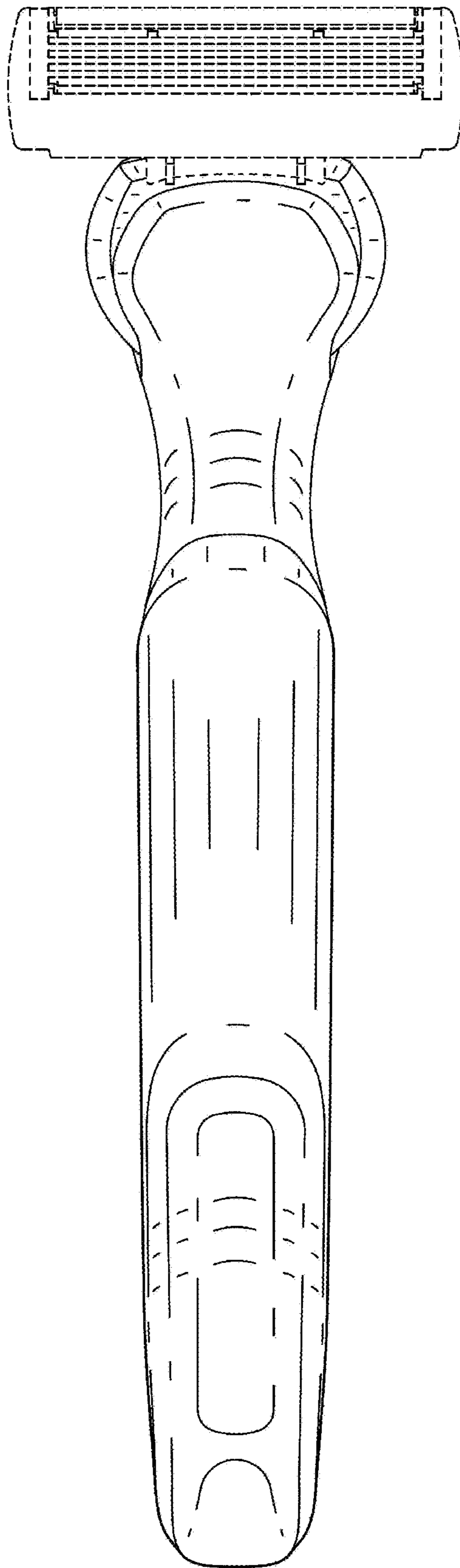

FIG. 4

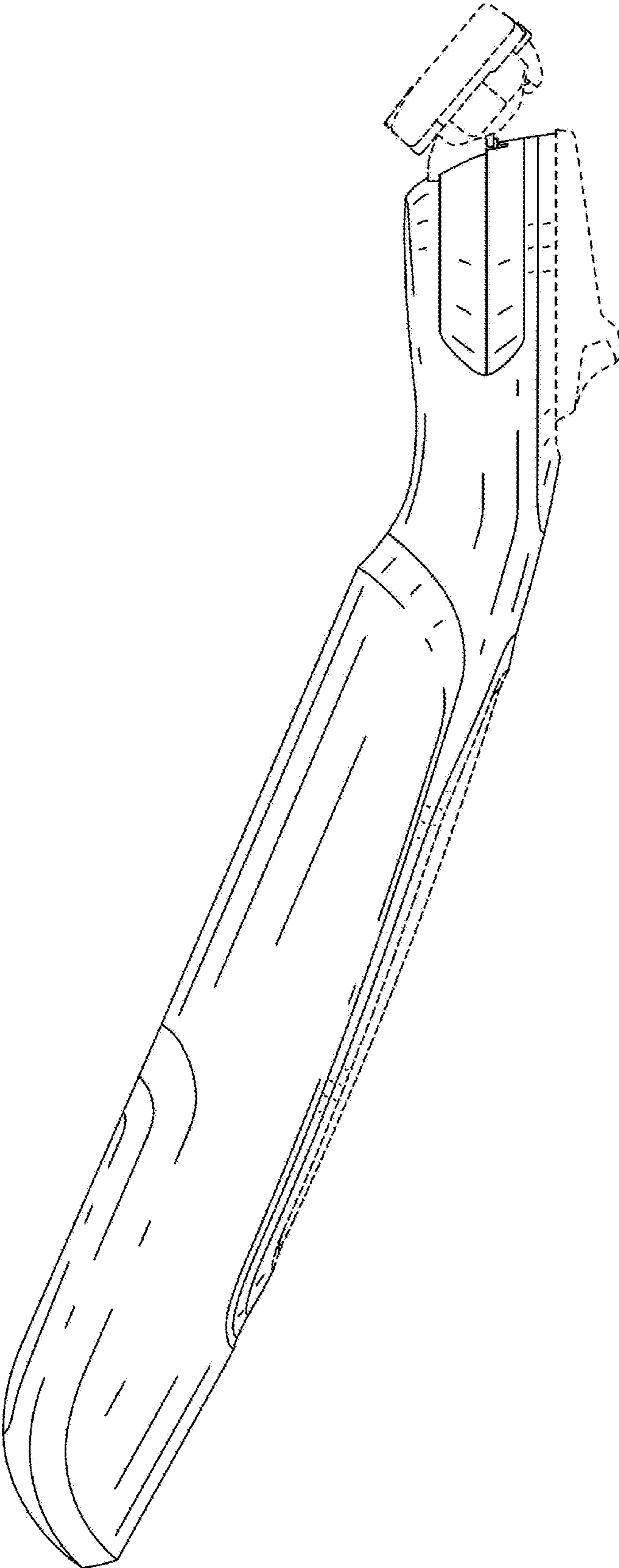

FIG. 5

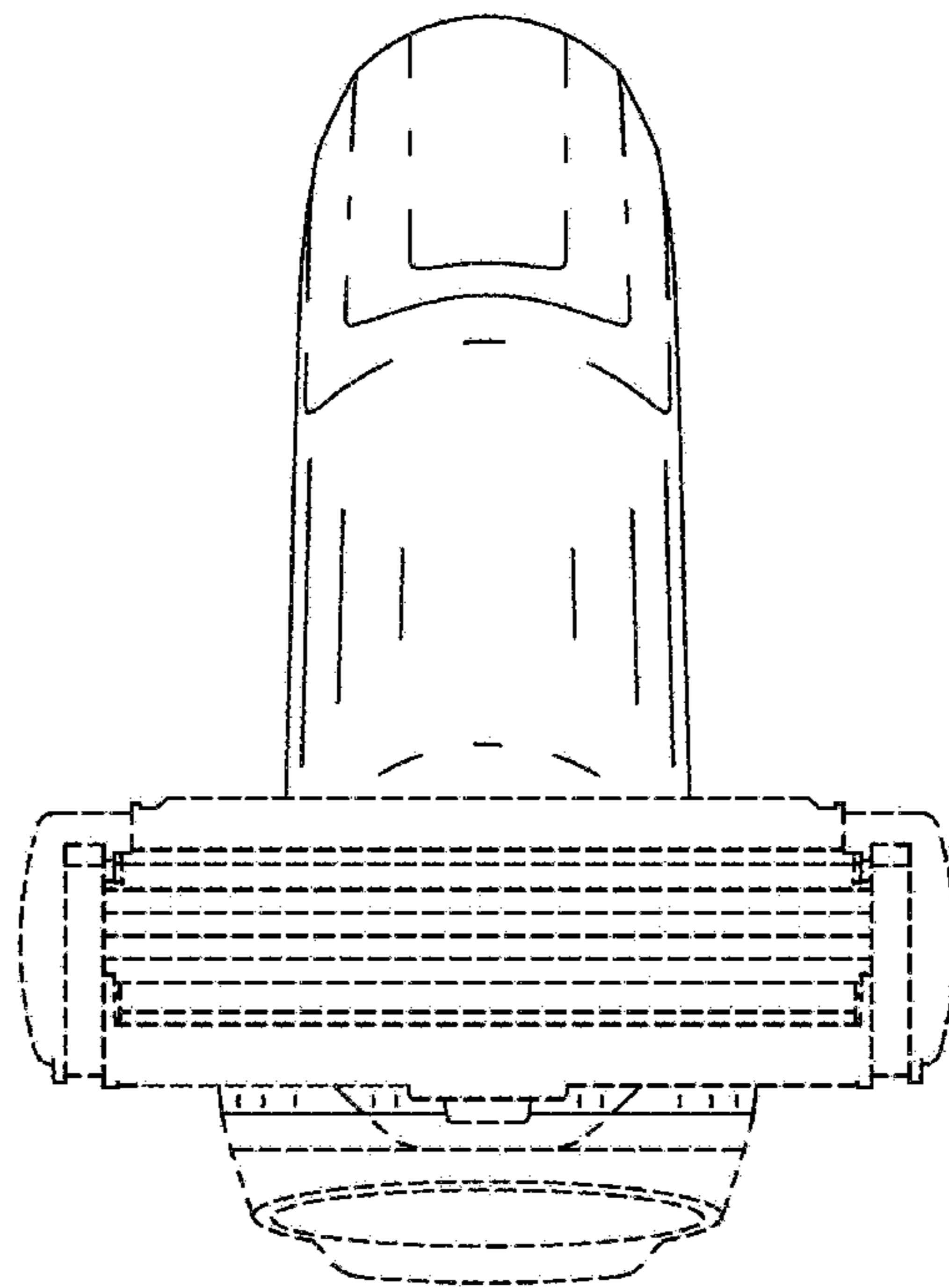

FIG. 6

