



US00D945020S

(12) **United States Design Patent**
Tucker

(10) **Patent No.:** **US D945,020 S**
(45) **Date of Patent:** **** Mar. 1, 2022**

- (54) **FAUX RAFTER TAIL**
- (71) Applicant: **Street Smart Buyer, LLC**, Holland, MI (US)
- (72) Inventor: **Phillip Tucker**, Holland, MI (US)
- (**) Term: **15 Years**
- (21) Appl. No.: **29/718,889**
- (22) Filed: **Dec. 30, 2019**
- (51) **LOC (13) Cl.** **25-02**
- (52) **U.S. Cl.**
USPC **D25/61**
- (58) **Field of Classification Search**
USPC D8/402; D25/55, 61, 102, 133
CPC E04D 13/158; E04B 9/005; E04F 19/02;
E04F 19/024
See application file for complete search history.

- 2009/0007516 A1* 1/2009 Swanson E04D 1/12
52/524
- 2010/0058691 A1* 3/2010 Mannion B32B 21/042
52/309.3
- 2013/0232889 A1* 9/2013 Rasmussen E04D 13/158
52/94
- 2017/0067259 A1* 3/2017 Guzman E04F 19/02
- 2020/0224426 A1* 7/2020 Tucker E04D 13/158

* cited by examiner

Primary Examiner — Leanne Was-Englehart
(74) *Attorney, Agent, or Firm* — Oppenhuizen Law PC;
David L. Oppenhuizen

(57) **CLAIM**

The ornamental design for a faux rafter tail, as shown and described.

DESCRIPTION

FIG. 1 is a top perspective view of a faux rafter tail showing the new design;
FIG. 2 is a bottom perspective view thereof;
FIG. 3 is a front view;
FIG. 4 is a right side view;
FIG. 5 is a rear view;
FIG. 6 is a left side view;
FIG. 7 is a top view; and,
FIG. 8 is a bottom view.

The faux rafter tail is shown with a symbolic break in its length at one end thereof. The appearance of any portion of the faux rafter tail between the break lines forms no part of the claimed design.

The broken lines depict portions of the faux rafter tail that form no part of the claimed design.

1 Claim, 3 Drawing Sheets

(56) **References Cited**

U.S. PATENT DOCUMENTS

- D309,708 S * 8/1990 Rosa D8/402
- D335,429 S * 5/1993 Scott, Jr D25/133
- D335,430 S * 5/1993 Scott, Jr D25/133
- D485,367 S * 1/2004 Skulsky D25/55
- 7,165,372 B1 * 1/2007 Skulsky B44C 5/00
256/19
- 8,146,307 B1 * 4/2012 Loper E04F 19/024
52/287.1
- D762,464 S * 8/2016 Peterson D8/402
- D783,394 S * 4/2017 Peterson D8/402
- 9,719,259 B2 * 8/2017 Guzman E04F 19/0436
- D856,128 S * 8/2019 Kazutaka D8/402
- 10,934,718 B2 * 3/2021 Tucker E04D 13/158

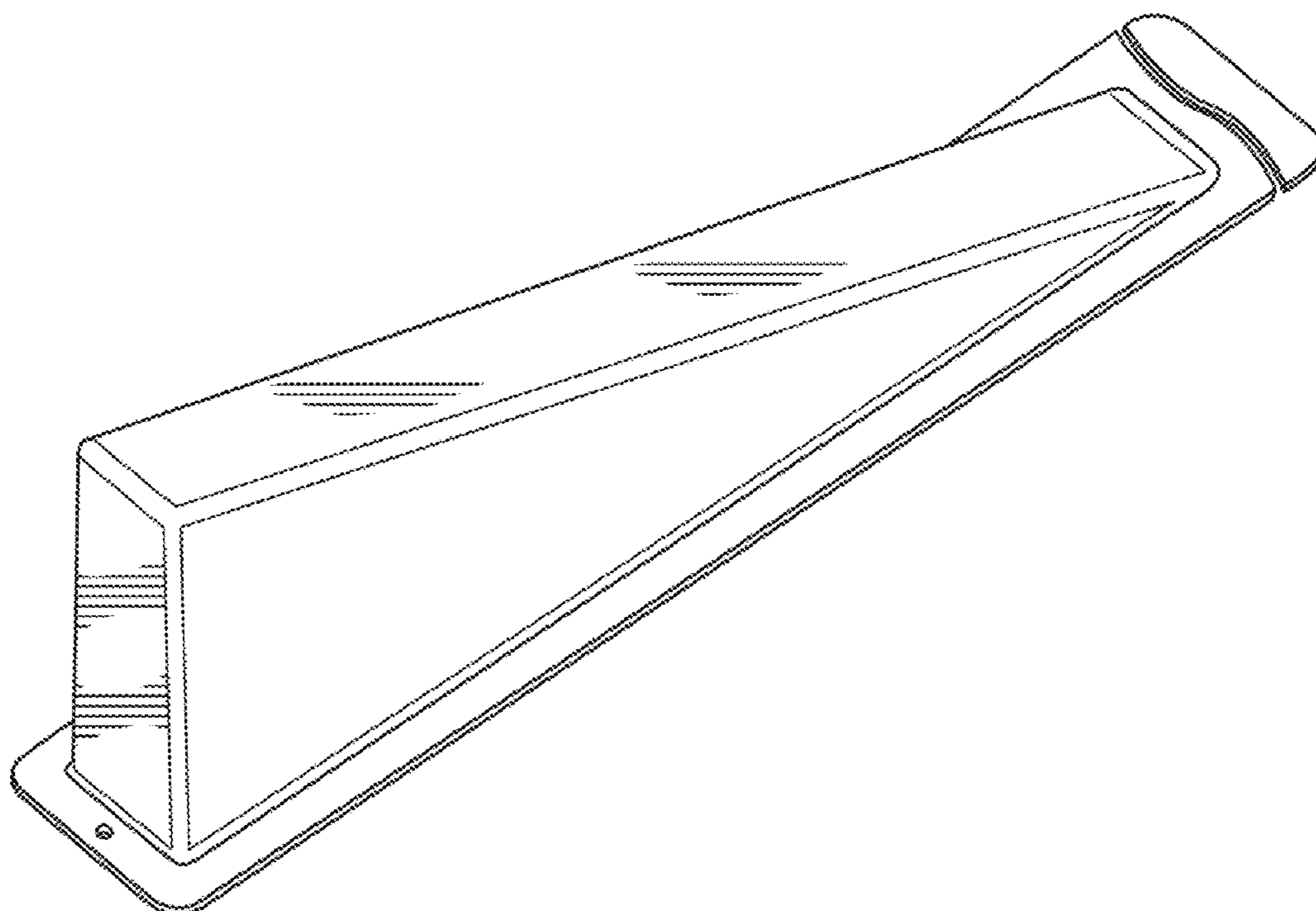

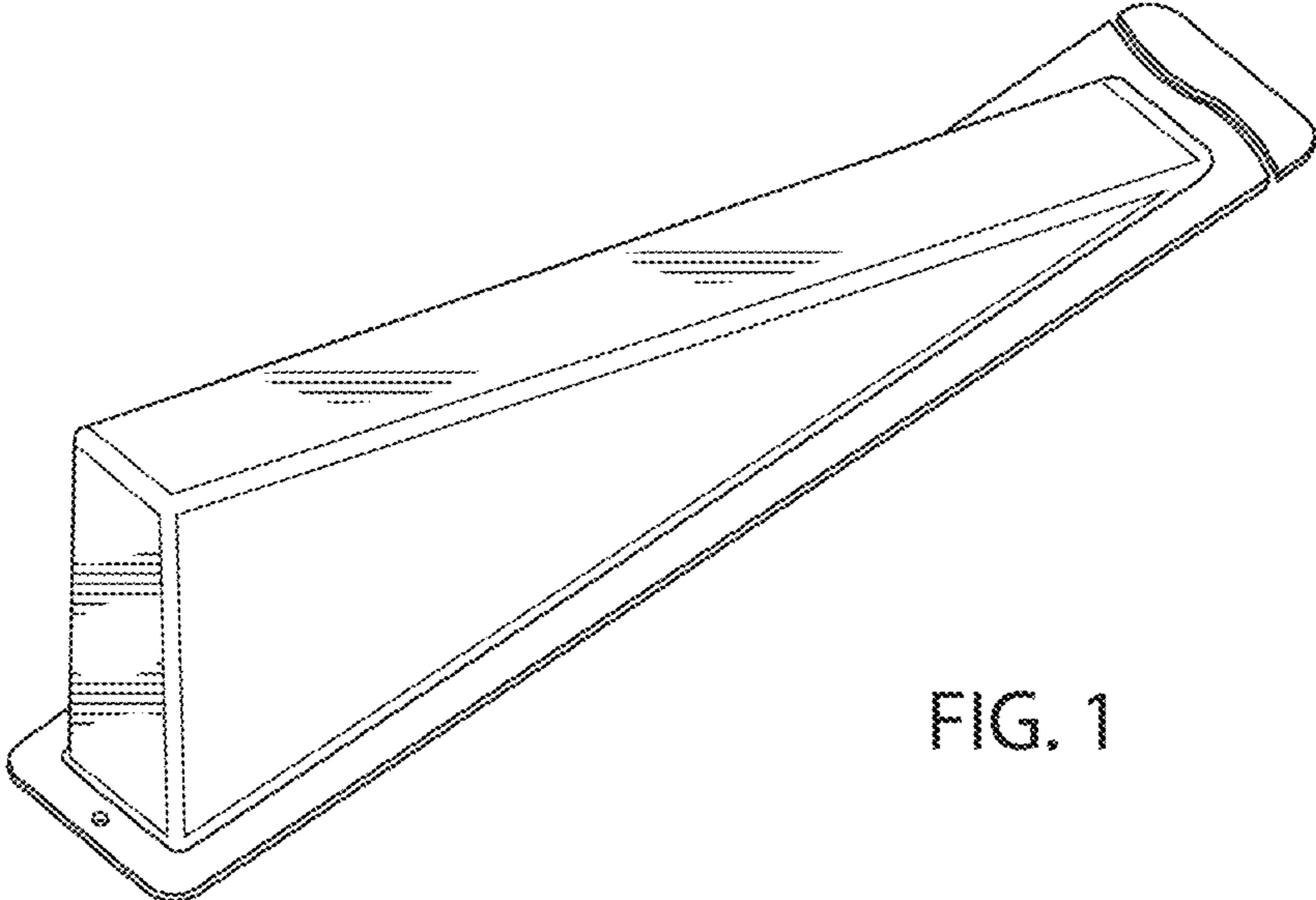

FIG. 1

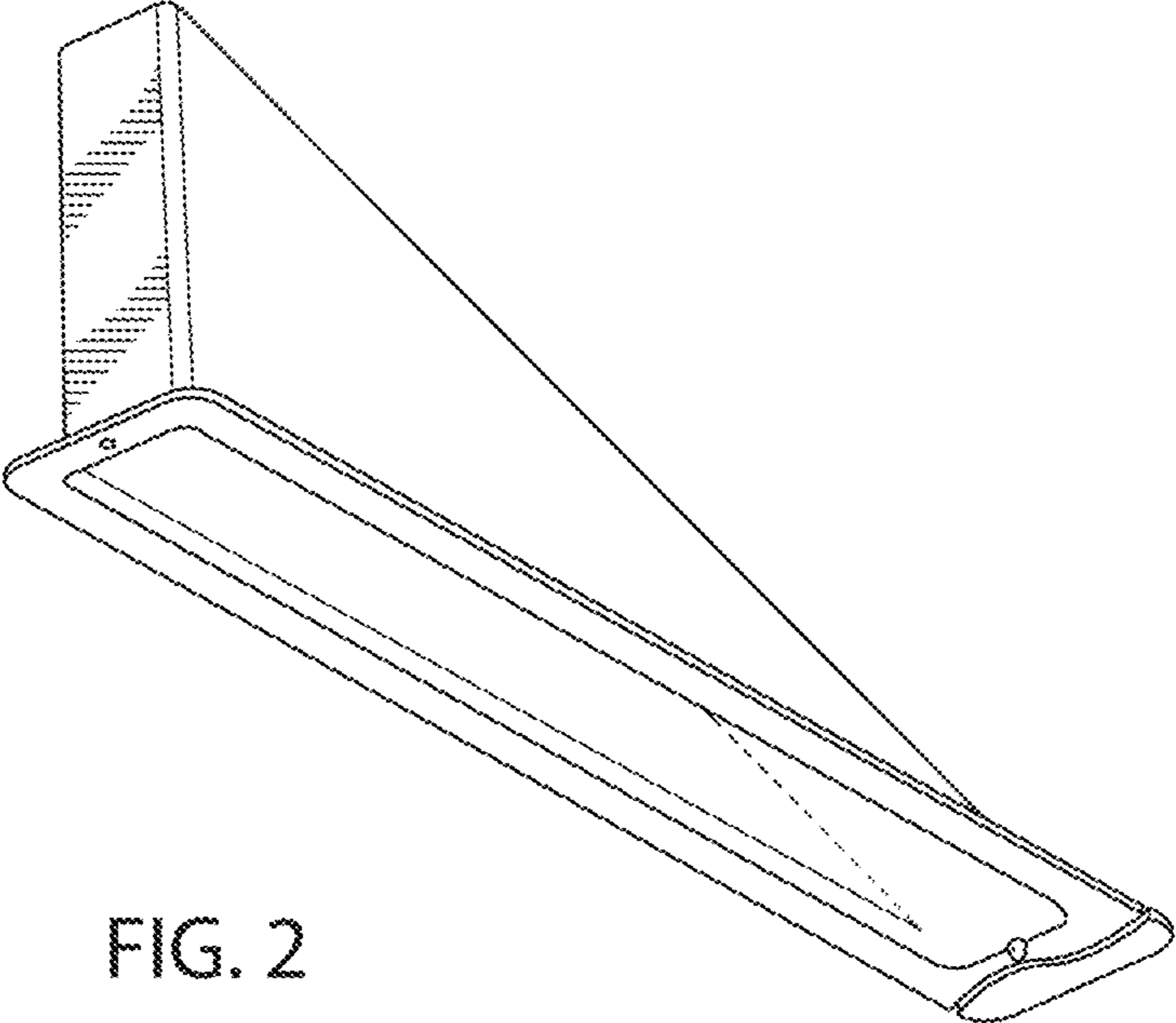

FIG. 2

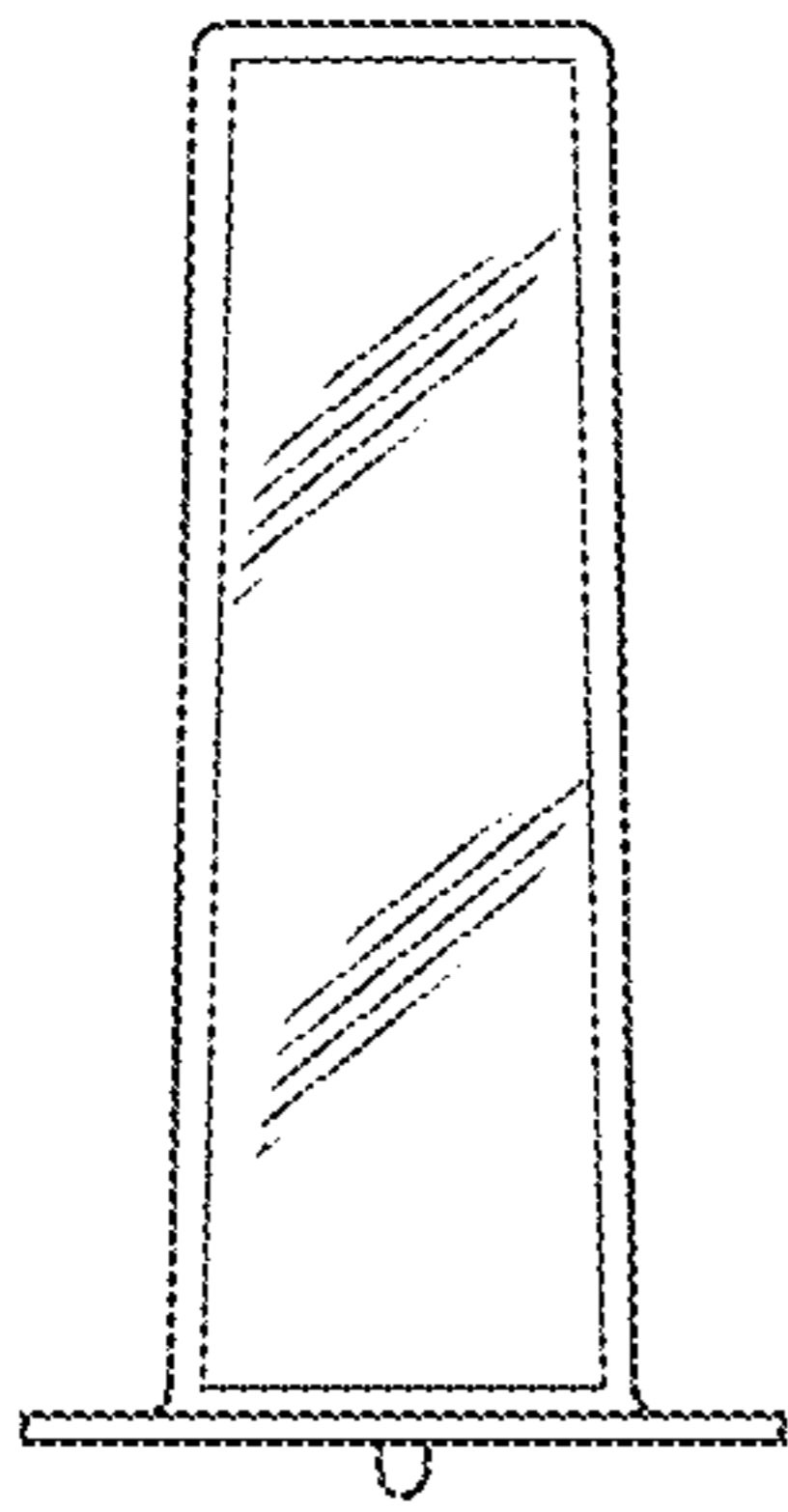

FIG. 3

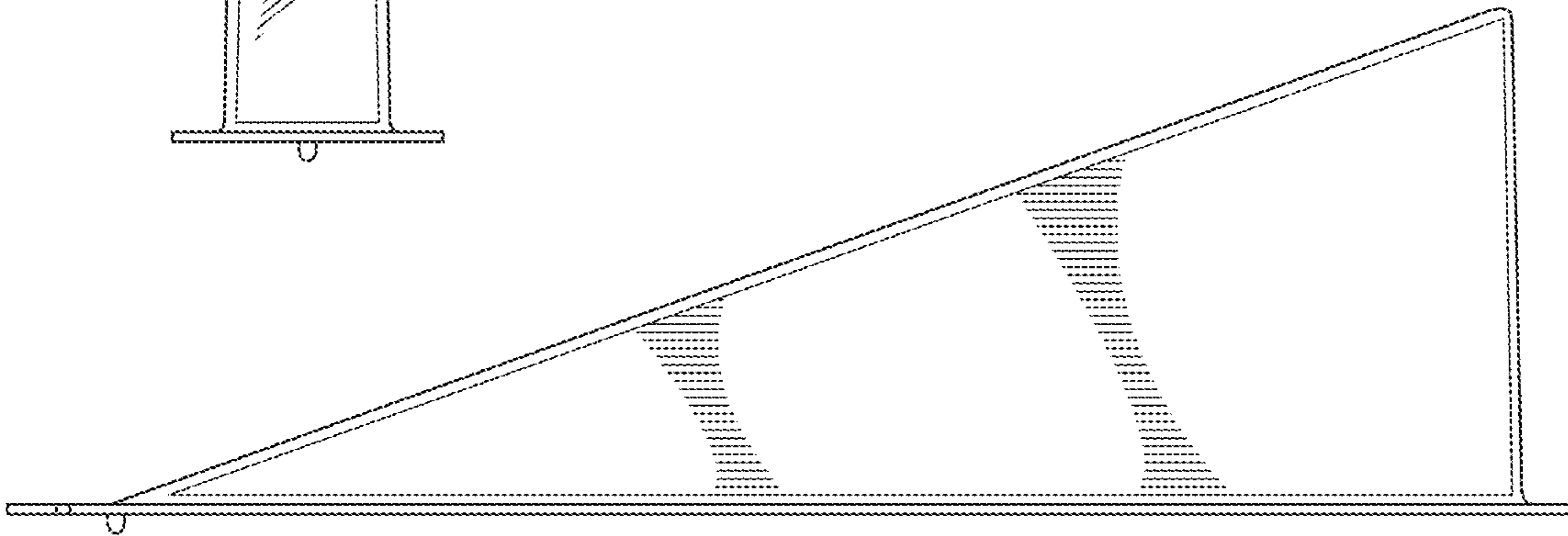

FIG. 4

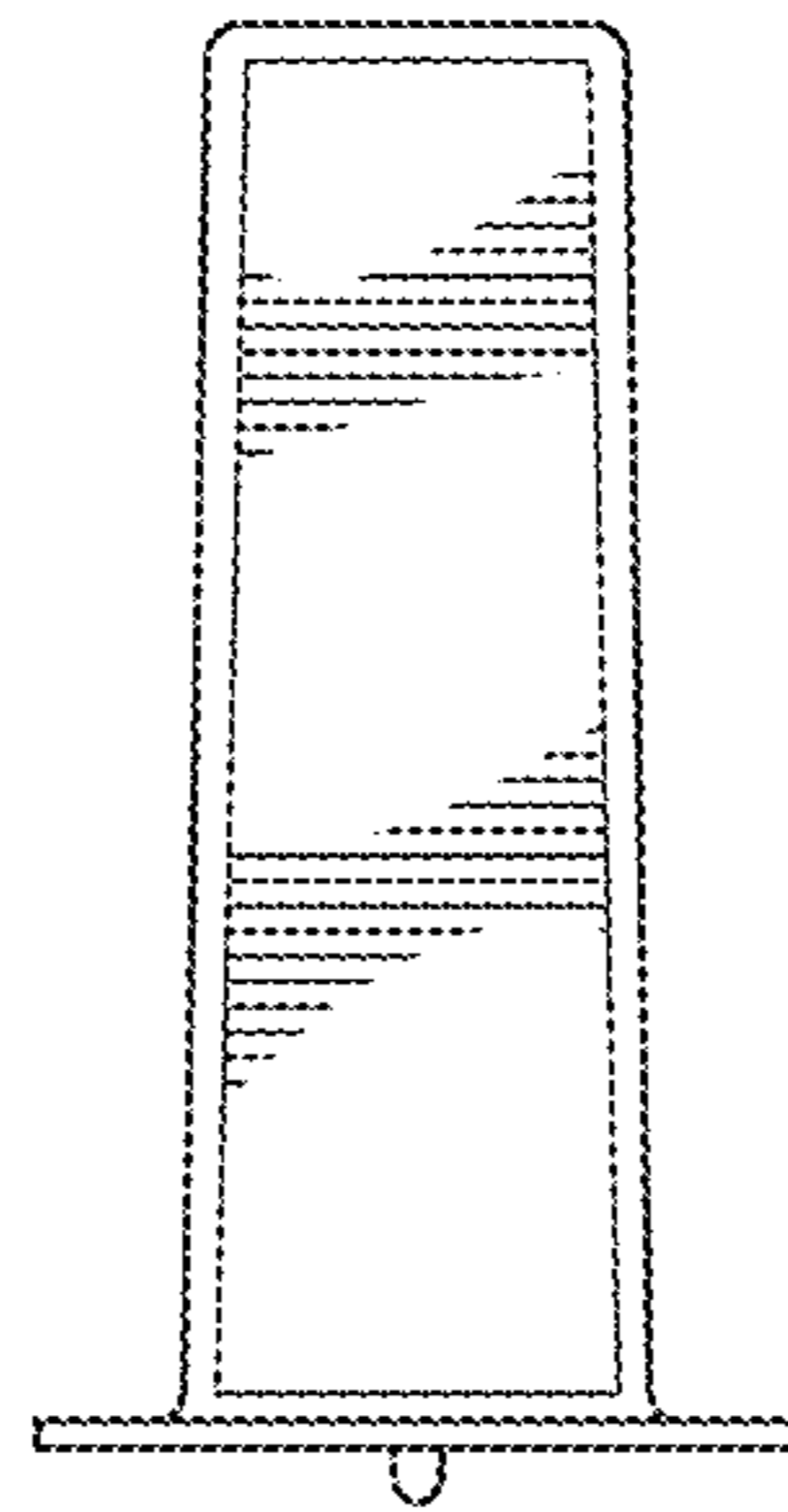

FIG. 5

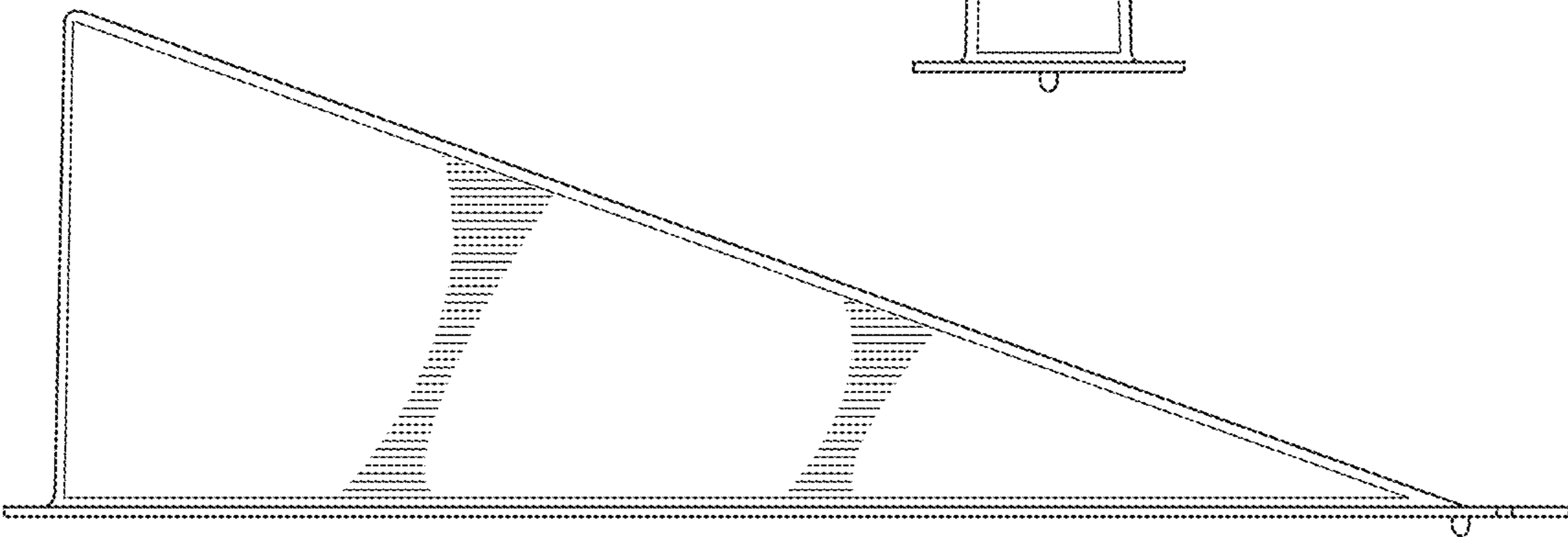

FIG. 6

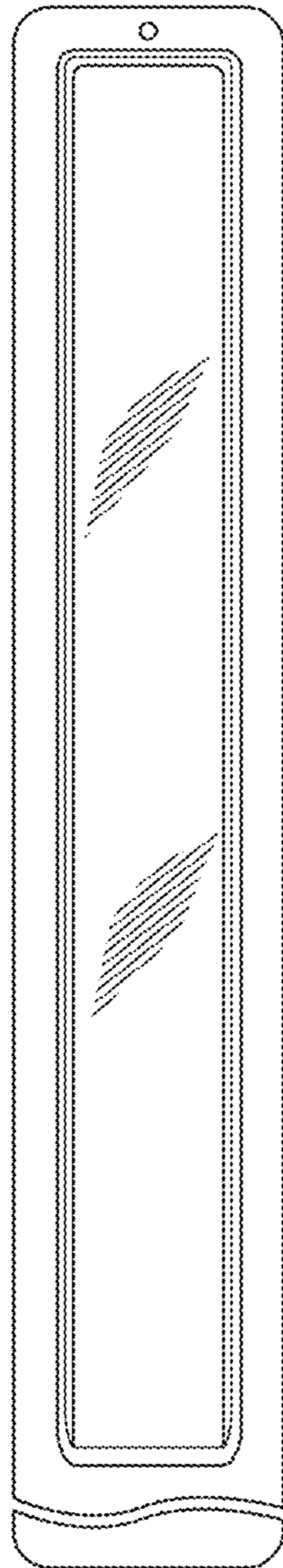

FIG. 7

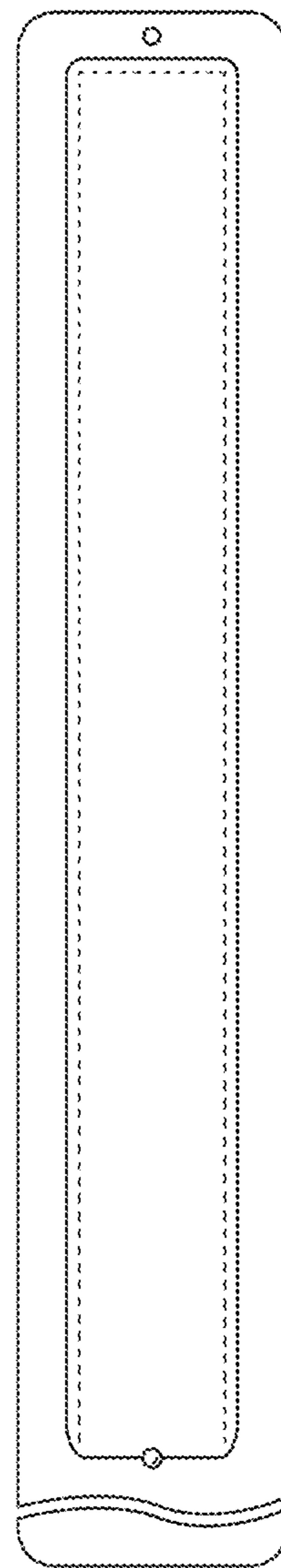

FIG. 8