



US00D944212S

(12) **United States Design Patent** (10) **Patent No.:** **US D944,212 S**
Peng et al. (45) **Date of Patent:** **** Feb. 22, 2022**

(54) **ELECTRICAL JUNCTION BOX**

(71) Applicant: **DMF, Inc.**, Carson, CA (US)
(72) Inventors: **Xinzhi Peng**, Downey, CA (US);
Michael D. Danesh, Carson, CA (US)
(73) Assignee: **DMF, Inc.**, Carson, CA (US)
(**) Term: **15 Years**

(21) Appl. No.: **29/694,475**

(22) Filed: **Jun. 11, 2019**

Related U.S. Application Data

(63) Continuation of application No. 29/541,565, filed on Oct. 5, 2015, now Pat. No. Des. 851,046.

(51) **LOC (13) Cl.** **13-03**

(52) **U.S. Cl.**
USPC **D13/152**

(58) **Field of Classification Search**

USPC D13/108, 110, 123, 133, 137.1–137.4,
D13/138.1–138.2, 139.1–139.8, 152–154,
D13/146, 147, 156, 158, 177, 184, 199;
D14/432, 433, 435.1; D8/350–353;
D25/102, 122, 124
CPC H01R 11/00; H01R 9/00; H01R 25/00;
H01R 25/006; H01R 13/6675; H01R
13/44; H01R 13/627; H01R 13/447;
H01R 13/73;

(Continued)

(56) **References Cited**

U.S. PATENT DOCUMENTS

1,133,535 A 3/1915 Cain et al.
1,471,340 A 10/1923 Knight
(Continued)

FOREIGN PATENT DOCUMENTS

CA 2243934 C 6/2002
CA 2502637 A1 9/2005
(Continued)

OTHER PUBLICATIONS

Civil Action No. 2:18-cv-07090. Complaint For Infringement And Unfair Competition. *DMF, Inc. v. AMP Plus, Inc. d/b/a ELCO Lighting*. 52 pages. dated Aug. 15, 2018.‡
(Continued)

Primary Examiner — Christy Nemeth
(74) *Attorney, Agent, or Firm* — Smith Baluch LLP

(57) **CLAIM**

The ornamental design for an electrical junction box, as shown and described.

DESCRIPTION

FIG. 1 is a top, side perspective view of an electrical junction box of our new design;
FIG. 2 is another top, side perspective view thereof;
FIG. 3 is a top plan view thereof;
FIG. 4 is a front elevation view thereof, the rear view being identical;
FIG. 5 is a right side view thereof, the left side view being identical;
FIG. 6 is a bottom plan view thereof;
FIG. 7 is a front, right, bottom perspective view thereof;
FIG. 8 is a top plan view of the electrical junction box of FIG. 1;
FIG. 9 is a front elevation view thereof
FIG. 10 is a right side view thereof, the left side view being identical;
FIG. 11 is a bottom plan view thereof; and,
FIG. 12 is a front, right, bottom perspective view thereof.
The dash-dash broken lines in the drawings are for the purpose of illustrating environmental subject matter and portions of the electrical junction box that form no part of the claimed design.

1 Claim, 12 Drawing Sheets

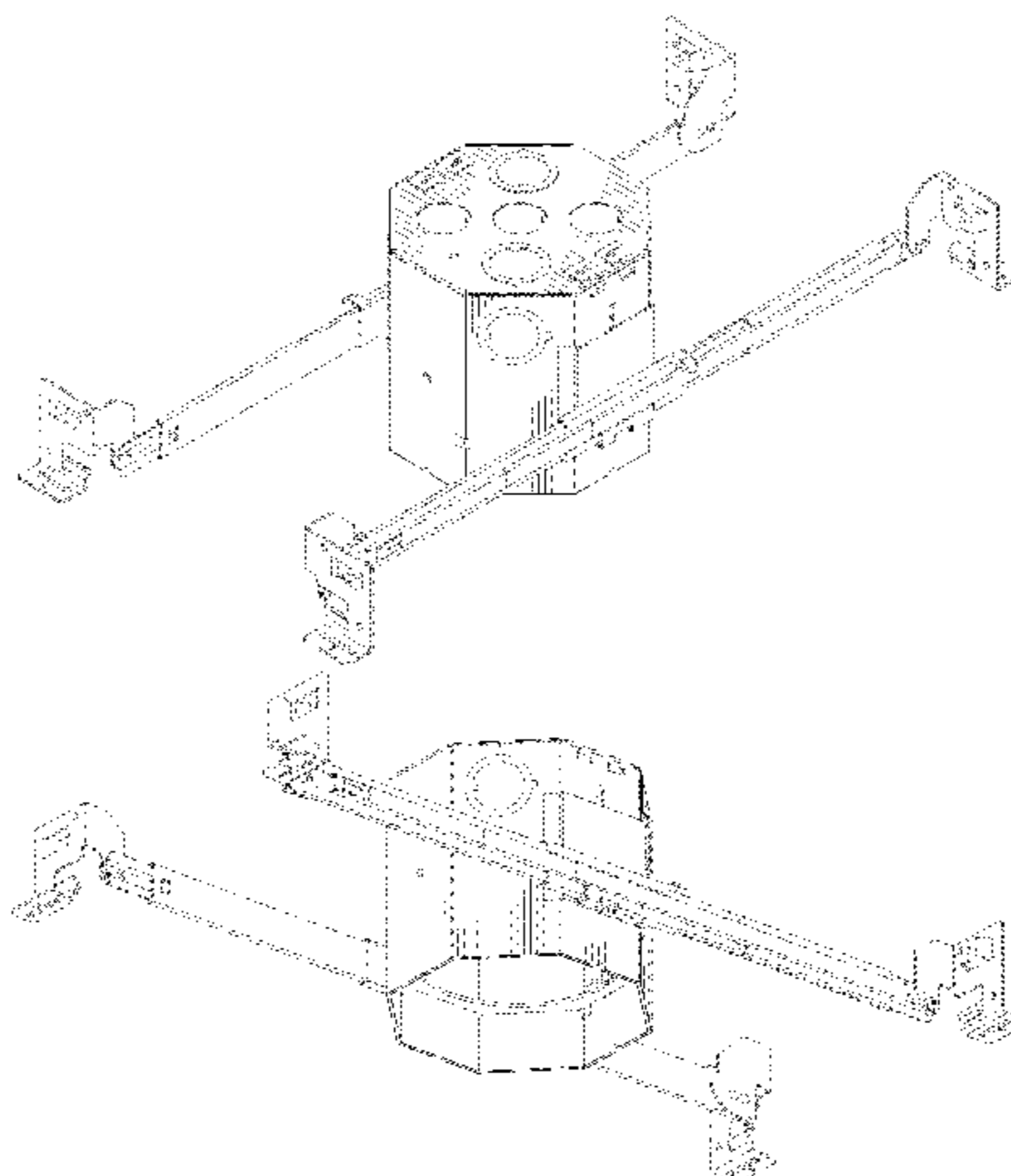

US D944,212 S

(58) **Field of Classification Search**
 CPC ... H01R 13/66; H01R 13/60; H01R 13/5845;
 H01R 13/72; H01R 13/46; H01R 31/065;
 H01R 31/06; H01R 24/28; H01R 27/00;
 H02J 2007/0062; H01L 37/2806; F21S
 8/02; F21V 23/00; F21V 23/01; F16J
 13/10; F16L 3/12; F16B 5/02; H01B
 7/2806
 See application file for complete search history.

4,910,651 A 3/1990 Montanez
 4,919,292 A 4/1990 Hsu
 4,929,187 A * 5/1990 Hudson F21V 21/03
 439/334
 4,930,054 A ‡ 5/1990 Krebs F21S 8/026
 362/14
 5,044,582 A 9/1991 Walters
 D326,537 S 5/1992 Gattari
 5,216,203 A * 6/1993 Gower H02G 3/088
 174/152 G

(56) **References Cited**

U.S. PATENT DOCUMENTS

1,856,356 A 5/1932 Owen
 2,038,784 A ‡ 4/1936 Ghadiali G03B 33/00
 362/26
 2,179,161 A 11/1939 Rambusch
 2,197,737 A 4/1940 Appleton
 2,352,913 A 7/1944 Morrill
 2,528,989 A 11/1950 Ammells
 2,597,595 A 5/1952 Ordas
 2,642,246 A 6/1953 Larry
 2,670,919 A 3/1954 Vincent
 2,697,535 A * 12/1954 Olson H02G 3/085
 220/3.2
 2,758,810 A 8/1956 Good
 D180,844 S 8/1957 Poliakoff
 2,802,933 A 8/1957 Harry
 2,998,512 A 8/1961 Duchene et al.
 3,023,920 A 3/1962 Cook et al.
 3,057,993 A 10/1962 Gellert
 3,104,087 A 9/1963 Joseph et al.
 3,214,126 A 10/1965 Roos
 3,422,261 A ‡ 1/1969 Mcginty F21S 8/02
 362/29
 3,460,299 A ‡ 8/1969 Wilson E04B 9/303
 52/144
 3,650,046 A ‡ 3/1972 Skinner G09B 3/04
 434/32
 3,675,807 A 7/1972 Lund et al.
 3,700,885 A 10/1972 Bobrick
 3,711,053 A 1/1973 Drake
 D227,989 S 7/1973 Geisel
 3,773,968 A 11/1973 Copp
 3,812,342 A ‡ 5/1974 McNamara, Jr. F21V 3/04
 362/37
 3,836,766 A 9/1974 Auerbach
 3,874,035 A 4/1975 Schuplin
 3,913,773 A 10/1975 Copp et al.
 D245,905 S 9/1977 Taylor
 4,088,827 A ‡ 5/1978 Kohaut H02G 3/185
 174/48
 4,176,758 A 12/1979 Glick
 4,280,169 A 7/1981 Allen
 4,399,497 A ‡ 8/1983 Druffel F21S 8/02
 362/36
 4,450,512 A 5/1984 Kristofek
 4,460,948 A 7/1984 Malola
 4,520,435 A ‡ 5/1985 Baldwin F21S 8/033
 362/31
 4,539,629 A 9/1985 Poppenheimer
 4,601,145 A ‡ 7/1986 Wilcox E04B 2/7444
 160/13
 4,667,840 A 5/1987 Lindsey
 4,723,747 A ‡ 2/1988 Karp F21V 21/04
 248/29
 4,729,080 A ‡ 3/1988 Fremont F21V 21/04
 362/14
 4,754,377 A ‡ 6/1988 Wenman F21S 8/02
 362/14
 4,757,908 A ‡ 7/1988 Medlin, Sr. H02G 3/126
 220/3.7
 4,770,311 A * 9/1988 Wang H02G 3/123
 220/3.2
 4,880,128 A 11/1989 Jorgensen

5,222,800 A 6/1993 Chan et al.
 5,239,132 A 8/1993 Bartow
 5,250,269 A ‡ 10/1993 Langer B01D 53/885
 422/17
 5,266,050 A 11/1993 O'Neil et al.
 5,303,894 A 4/1994 Deschamps et al.
 5,382,752 A ‡ 1/1995 Reyhan H02G 3/088
 174/38
 5,420,376 A 5/1995 Rajecki et al.
 5,465,199 A ‡ 11/1995 Bray F21S 8/02
 362/14
 5,505,419 A 4/1996 Gabrius
 5,544,870 A ‡ 8/1996 Kelley A47D 13/065
 256/25
 5,562,343 A ‡ 10/1996 Chan F21S 8/02
 362/14
 5,571,993 A ‡ 11/1996 Jones H02G 3/185
 174/57
 5,580,158 A ‡ 12/1996 Aubrey F21S 8/02
 362/26
 5,588,737 A ‡ 12/1996 Kusmer F21V 19/0005
 174/66
 5,603,424 A ‡ 2/1997 Bordwell H02G 3/123
 220/3
 5,609,408 A 3/1997 Targetti
 5,613,338 A 3/1997 Esposito
 D381,111 S ‡ 7/1997 Lecluze D26/11
 5,662,413 A ‡ 9/1997 Akiyama F21S 8/02
 362/14
 D386,277 S ‡ 11/1997 Lecluze D26/11
 5,690,423 A ‡ 11/1997 Hentz F21S 8/02
 248/302
 D387,466 S ‡ 12/1997 Lecluze D26/11
 5,738,436 A ‡ 4/1998 Cummings F21S 2/00
 362/29
 5,778,625 A 7/1998 Druffel et al.
 5,836,678 A ‡ 11/1998 Wright F21S 8/02
 362/36
 5,942,726 A ‡ 8/1999 Reiker E04B 9/006
 174/58
 5,944,412 A ‡ 8/1999 Janos F21V 21/04
 362/14
 5,957,573 A 9/1999 Wedekind et al.
 5,975,323 A ‡ 11/1999 Turan H02G 3/086
 220/3
 6,030,102 A 2/2000 Gromotka
 6,082,878 A ‡ 7/2000 Doubek F21S 8/026
 211/26
 6,095,669 A 8/2000 Cho
 6,098,945 A 8/2000 Korcz
 6,105,334 A ‡ 8/2000 Monson F21S 8/02
 52/232
 6,161,910 A ‡ 12/2000 Reisenauer H05B 45/46
 315/30
 6,170,685 B1 ‡ 1/2001 Currier H02G 3/121
 220/3
 6,174,076 B1 ‡ 1/2001 Petrakis F21V 17/00
 362/14
 6,176,599 B1 1/2001 Farzen
 6,267,491 B1 ‡ 7/2001 Parrigin F21S 43/51
 362/54
 6,332,597 B1 12/2001 Korcz et al.
 6,350,043 B1 ‡ 2/2002 Gloisten B64D 11/00
 362/28
 6,350,046 B1 2/2002 Lau
 6,364,511 B1 ‡ 4/2002 Cohen F21S 8/02
 362/14

(56)

References Cited

U.S. PATENT DOCUMENTS

6,375,338 B1	4/2002	Cummings et al.	D555,106 S	11/2007	Pape et al.
6,402,112 B1	6/2002	Thomas et al.	D556,144 S	11/2007	Dinh
D461,455 S ‡	8/2002	Forbes D13/15	7,297,870 B1 ‡	11/2007	Sartini H02G 3/125
6,461,016 B1	10/2002	Jamison et al.			174/50
6,474,846 B1 ‡	11/2002	Kelmelis F21V 17/164	7,312,474 B2 ‡	12/2007	Emerson H01L 21/02505
		248/23			257/96
6,491,413 B1 ‡	12/2002	Benesohn F21S 8/02	7,320,536 B2 ‡	1/2008	Petrakis F21S 8/02
		362/29			362/14
D468,697 S	1/2003	Straub, Jr.	D561,372 S ‡	2/2008	Yan D26/72
D470,970 S	2/2003	Huang	D561,373 S ‡	2/2008	Yan D26/72
6,515,313 B1 ‡	2/2003	Ibbetson H01L 33/32	7,335,920 B2 ‡	2/2008	Denbaars H01L 33/145
		257/10			257/79
6,521,833 B1	2/2003	DeFreitas	D563,896 S	3/2008	Greenslate
D471,657 S	3/2003	Huang	7,347,580 B2 ‡	3/2008	Blackman F21V 21/02
6,583,573 B2 ‡	6/2003	Bierman H05B 39/042			362/14
		250/21	D570,012 S ‡	5/2008	Huang D26/28
6,585,389 B2 ‡	7/2003	Bonazzi F21V 7/24	7,374,308 B2 ‡	5/2008	Sevack F21V 21/04
		362/14			362/14
6,600,175 B1 ‡	7/2003	Baretz H01L 33/50	D570,504 S ‡	6/2008	Maxik D26/2
		257/10	D570,505 S ‡	6/2008	Maxik D26/2
D478,872 S	8/2003	Heggem	7,399,104 B2 ‡	7/2008	Rappaport F21S 8/02
6,632,006 B1	10/2003	Rippel et al.			362/14
6,657,236 B1 ‡	12/2003	Thibeault H01L 33/20	7,429,025 B1 *	9/2008	Gretz H02G 3/20
		257/98			248/546
6,666,419 B1	12/2003	Vrame	D578,677 S ‡	10/2008	Huang D26/28
D488,583 S ‡	4/2004	Benghozi D26/11	7,431,482 B1 ‡	10/2008	Morgan F21S 2/005
6,719,438 B2 ‡	4/2004	Sevack F21S 8/02			362/36
		362/14	7,432,440 B2	10/2008	Hull et al.
6,758,578 B1 ‡	7/2004	Chou F21V 17/06	7,442,883 B2	10/2008	Jolly et al.
		362/39	7,446,345 B2 ‡	11/2008	Emerson H01L 33/24
6,777,615 B1 *	8/2004	Gretz F04D 25/088			257/95
		174/491	7,470,048 B2	12/2008	Wu
6,779,908 B1	8/2004	Ng	7,473,005 B2 ‡	1/2009	O'Brien F21S 8/02
6,827,229 B2	12/2004	Dinh et al.			362/14
6,838,618 B2	1/2005	Newbold et al.	7,488,097 B2 ‡	2/2009	Reisenauer F21K 9/68
6,906,352 B2 ‡	6/2005	Edmond B82Y 20/00			362/37
		257/10	7,494,258 B2	2/2009	McNaught
D509,314 S ‡	9/2005	Rashidi D26/12	7,503,145 B2 ‡	3/2009	Newbold F21V 25/12
6,948,829 B2 ‡	9/2005	Verdes F21V 3/00			52/28
		315/71	7,524,089 B2 ‡	4/2009	Park F21V 3/02
6,958,497 B2 ‡	10/2005	Emerson H01L 21/02505			362/29
		257/94	D591,894 S ‡	5/2009	Flank D26/74
6,964,501 B2 ‡	11/2005	Ryan F21V 29/004	7,534,989 B2 ‡	5/2009	Suehara G01N 21/8916
		362/29			250/22
6,967,284 B1 *	11/2005	Gretz H02G 3/125	D596,154 S	7/2009	Rivkin
		174/50	7,566,154 B2 ‡	7/2009	Gloisten F21V 29/70
D516,235 S ‡	2/2006	Rashidi D26/13			362/54
7,025,477 B2	4/2006	Blessing	D599,040 S ‡	8/2009	Alexander D26/1
7,064,269 B2 *	6/2006	Smith H01R 33/46	D600,836 S ‡	9/2009	Hanley D26/1
		174/481	7,588,359 B2 ‡	9/2009	Coushaine F21S 43/241
D528,673 S ‡	9/2006	Maxik D26/2			362/55
7,102,172 B2	9/2006	Lynch	7,592,583 B2 ‡	9/2009	Page G01J 1/02
D531,740 S ‡	11/2006	Maxik D26/2			250/20
D532,532 S ‡	11/2006	Maxik D26/2	7,625,105 B1 ‡	12/2009	Johnson F21S 8/02
7,148,420 B1	12/2006	Johnson et al.			362/14
7,148,632 B2	12/2006	Berman et al.	7,628,513 B2 ‡	12/2009	Chiu F21K 9/233
7,154,040 B1	12/2006	Tompkins			362/24
7,170,015 B1	1/2007	Roesch et al.	7,651,238 B2 ‡	1/2010	O'Brien F21S 8/02
D536,349 S	2/2007	Humber et al.			362/14
D537,039 S	2/2007	Pincek	7,654,705 B2 ‡	2/2010	Czech F21S 8/02
D539,229 S	3/2007	Murphey			362/14
7,186,008 B2 ‡	3/2007	Patti F21S 8/02	D611,650 S ‡	3/2010	Broekhoff D26/13
		362/14	7,670,021 B2 ‡	3/2010	Chou F21S 8/026
7,190,126 B1 ‡	3/2007	Paton H05B 47/19			362/14
		315/30	7,673,841 B2	3/2010	Wronski
7,211,833 B2 ‡	5/2007	Slater, Jr H01L 33/405	7,677,766 B2 ‡	3/2010	Boyer F21K 9/00
		257/75			362/24
7,213,940 B1 ‡	5/2007	Van De Ven H05B 45/20	7,692,182 B2 ‡	4/2010	Bergmann H01L 33/32
		362/23			257/22
7,234,674 B2	6/2007	Rippel et al.	7,704,763 B2 ‡	4/2010	Fujii H01L 33/007
D547,889 S ‡	7/2007	Huang D26/28			438/29
D552,969 S	10/2007	Bobrowski et al.	D616,118 S ‡	5/2010	Thomas D26/2
D553,267 S ‡	10/2007	Yuen D26/2	7,712,922 B2	5/2010	Hacker et al.
			7,722,208 B1 ‡	5/2010	Dupre F21V 7/00
					362/14
			7,722,227 B2 ‡	5/2010	Zhang F21S 8/026
					362/14

(56)

References Cited

U.S. PATENT DOCUMENTS

- 7,735,795 B2 6/2010 Wronski
7,735,798 B2 6/2010 Kojima
7,748,887 B2 † 7/2010 Zampini, II B63B 45/06
362/14
7,766,518 B2 † 8/2010 Piepgras F21K 9/00
362/37
7,769,192 B2 † 8/2010 Takagi H04R 9/06
356/13
7,771,082 B2 † 8/2010 Peng F21V 23/02
362/24
7,771,094 B2 † 8/2010 Goode H02G 3/20
362/145
7,784,754 B2 8/2010 Nevers et al.
D624,691 S 9/2010 Zhang et al.
D624,692 S † 9/2010 Mackin D26/14
D625,847 S † 10/2010 Maglica D26/1
D625,876 S † 10/2010 Chen D26/74
D627,507 S 11/2010 Lai et al.
D627,727 S † 11/2010 Alexander D13/13
7,828,465 B2 † 11/2010 Roberge F21V 29/74
362/29
D629,366 S 12/2010 Ericson et al.
7,845,393 B2 12/2010 Kao et al.
7,857,275 B2 12/2010 de la Borbolla
7,871,184 B2 † 1/2011 Peng F21K 9/233
361/70
7,874,539 B2 1/2011 Wright et al.
7,874,703 B2 1/2011 Shastry et al.
7,874,709 B1 1/2011 Beadle
D633,224 S † 2/2011 Lee D26/2
7,909,487 B1 3/2011 Venetucci et al.
D636,117 S 4/2011 Kim et al.
D636,118 S 4/2011 Kim et al.
D636,903 S † 4/2011 Torenbeek D26/2
D637,339 S † 5/2011 Hasan D26/72
D637,340 S † 5/2011 Hasan D26/72
7,950,832 B2 † 5/2011 Tanaka F21V 5/04
362/31
D639,499 S † 6/2011 Choi D26/13
7,956,546 B2 6/2011 Hasnain
7,959,332 B2 † 6/2011 Tickner F21S 8/02
362/37
7,967,480 B2 † 6/2011 Pickard F21V 21/048
362/36
D642,317 S † 7/2011 Rashidi D26/74
7,972,035 B2 † 7/2011 Boyer F16B 5/0258
362/24
7,972,043 B2 † 7/2011 Schutte F21V 21/04
362/36
D642,536 S 8/2011 Robinson
D643,970 S † 8/2011 Kim D26/12
7,993,037 B1 8/2011 Buse
8,002,425 B2 8/2011 Russo et al.
D646,011 S † 9/2011 Rashidi D26/74
8,013,243 B2 9/2011 Korcz et al.
8,038,113 B2 † 10/2011 Fryzek F21S 8/026
248/34
D648,476 S † 11/2011 Choi D26/11
D648,477 S † 11/2011 Kim D26/11
D650,115 S † 12/2011 Kim D26/11
8,070,328 B1 † 12/2011 Knoble F21V 3/00
362/31
8,096,670 B2 † 1/2012 Trott F21S 8/02
362/14
D654,205 S † 2/2012 Rashidi D26/74
D656,262 S † 3/2012 Yoshinobu D26/74
D656,263 S † 3/2012 Ogawa D26/74
8,142,057 B2 † 3/2012 Roos F21S 8/026
362/36
8,152,334 B2 † 4/2012 Krogman F21V 5/04
362/24
D658,788 S † 5/2012 Dudik D26/2
D658,802 S † 5/2012 Chen D26/74
D659,862 S † 5/2012 Tsai D26/2
D659,879 S † 5/2012 Rashidi D26/74
D660,814 S † 5/2012 Wilson D13/18
8,182,116 B2 † 5/2012 Zhang F21S 8/026
362/29
8,201,968 B2 † 6/2012 Maxik F21S 8/026
362/23
D663,058 S † 7/2012 Pan D26/2
D663,466 S † 7/2012 Rashidi D26/74
D664,274 S † 7/2012 De Visser D26/2
D664,705 S † 7/2012 Kong D26/11
8,215,805 B2 † 7/2012 Cogliano F21S 8/02
362/36
8,220,970 B1 † 7/2012 Khazi F21V 29/004
362/29
8,226,270 B2 † 7/2012 Yamamoto F21V 17/14
362/29
8,235,549 B2 8/2012 Gingrich, III et al.
8,240,630 B2 8/2012 Wronski
D667,155 S † 9/2012 Rashidi D26/74
8,262,255 B1 † 9/2012 Rashidi F21V 29/505
362/24
D668,809 S † 10/2012 Rashidi D26/74
D669,198 S † 10/2012 Qiu D26/2
D669,199 S † 10/2012 Chuang D26/2
D669,620 S † 10/2012 Rashidi D26/74
8,277,090 B2 † 10/2012 Fryzek F21V 21/048
248/90
D671,668 S 11/2012 Rowlette, Jr. et al.
8,308,322 B2 † 11/2012 Santiago F21V 21/048
220/47
D672,899 S 12/2012 Van De Ven et al.
D673,869 S † 1/2013 Yu D10/11
D676,263 S † 2/2013 Birke D6/695
D676,814 S 2/2013 Paul
8,376,593 B2 † 2/2013 Bazydola F21S 8/02
362/37
D677,417 S † 3/2013 Rashidi F21S 8/026
D26/74
D677,634 S † 3/2013 Korcz D13/152
D679,044 S 3/2013 Jeswani et al.
D679,047 S † 3/2013 Tickner D26/12
8,403,533 B1 † 3/2013 Paulsel F21S 8/026
362/24
8,403,541 B1 † 3/2013 Rashidi F21S 8/026
257/71
8,405,947 B1 3/2013 Green et al.
D681,259 S † 4/2013 Kong D26/11
8,408,759 B1 † 4/2013 Rashidi F21S 8/026
362/37
D683,063 S † 5/2013 Lopez D26/11
D683,890 S † 6/2013 Lopez D26/11
D684,269 S † 6/2013 Wang D24/20
D684,287 S 6/2013 Rashidi
D684,719 S † 6/2013 Rashidi D26/74
D685,118 S † 6/2013 Rashidi D26/74
D685,120 S † 6/2013 Rashidi D26/74
8,454,204 B1 † 6/2013 Chang F21V 17/002
362/29
D685,507 S † 7/2013 Sun D26/2
D687,586 S † 8/2013 Rashidi D26/74
D687,587 S † 8/2013 Rashidi D26/74
D687,588 S † 8/2013 Rashidi D26/74
D687,980 S * 8/2013 Gravely D26/2
D688,405 S † 8/2013 Kim D26/72
8,506,127 B2 8/2013 Russello et al.
8,506,134 B2 8/2013 Wilson et al.
D690,049 S † 9/2013 Rashidi D26/74
D690,864 S † 10/2013 Rashidi D26/74
D690,865 S † 10/2013 Rashidi D26/74
D690,866 S † 10/2013 Rashidi D26/74
D691,314 S † 10/2013 Rashidi D26/74
D691,315 S † 10/2013 Samson D26/74
D691,763 S † 10/2013 Hand D26/89
8,550,669 B2 † 10/2013 Macwan F21S 8/026
362/36
D693,043 S † 11/2013 Schmalfluss D26/63
D693,517 S † 11/2013 Davis D26/13

(56)

References Cited

U.S. PATENT DOCUMENTS

- D694,456 S † 11/2013 Rowlette, Jr D26/74
D695,441 S † 12/2013 Lui D26/74
D695,941 S † 12/2013 Rashidi
D696,446 S † 12/2013 Huh D26/74
D696,447 S † 12/2013 Huh D26/74
D696,448 S † 12/2013 Huh D26/74
8,602,601 B2 † 12/2013 Khazi F21V 17/16
362/29
D698,067 S † 1/2014 Rashidi D26/74
D698,068 S † 1/2014 Rashidi D26/74
8,622,361 B2 1/2014 Wronski
8,632,040 B2 1/2014 Mass et al.
D698,985 S † 2/2014 Lopez D26/11
D699,384 S † 2/2014 Rashidi D26/74
D699,687 S † 2/2014 Baldwin et al.
D700,387 S † 2/2014 Snell D26/74
8,641,243 B1 † 2/2014 Rashidi F21S 8/02
257/71
8,659,034 B2 † 2/2014 Baretz G09F 13/04
257/79
D700,991 S 3/2014 Johnson et al.
D701,175 S 3/2014 Baldwin et al.
D701,466 S † 3/2014 Clifford D10/11
8,672,518 B2 † 3/2014 Boomgaarden F21S 8/026
362/29
D702,867 S † 4/2014 Kim D26/72
D703,843 S † 4/2014 Cheng D26/2
8,684,569 B2 † 4/2014 Pickard F21V 13/14
362/38
8,696,158 B2 4/2014 Santiago et al.
D705,472 S † 5/2014 Huh D26/74
D705,481 S 5/2014 Zhang et al.
8,727,582 B2 † 5/2014 Brown F21V 21/04
220/3
8,777,449 B2 7/2014 Ven et al.
D710,529 S † 8/2014 Lopez D26/11
8,801,217 B2 † 8/2014 Oehle F21S 8/026
362/23
8,820,985 B1 9/2014 Tam et al.
8,833,013 B2 9/2014 Harman
8,845,144 B1 9/2014 Davies et al.
D714,989 S † 10/2014 Rowlette, Jr D26/74
8,870,426 B2 † 10/2014 Biebl F21S 41/192
362/54
8,890,414 B2 † 11/2014 Rowlette, Jr F21V 23/02
315/11
D721,845 S † 1/2015 Lui D26/74
8,926,133 B2 1/2015 Booth
8,939,418 B2 1/2015 Green et al.
D722,296 S † 2/2015 Taylor D13/15
D722,977 S † 2/2015 Hagarty
D722,978 S † 2/2015 Hagarty D13/15
8,950,898 B2 † 2/2015 Catalano F21K 9/23
362/24
D723,781 S 3/2015 Miner
D723,783 S 3/2015 Miner
D725,359 S 3/2015 Miner
8,967,575 B1 3/2015 Gretz
D726,363 S † 4/2015 Danesh D26/13
D728,129 S 4/2015 Kreuzbichler
9,004,435 B2 4/2015 Wronski
9,039,254 B2 † 5/2015 Danesh F21V 21/30
362/36
D731,689 S † 6/2015 Bernard D26/74
9,062,866 B1 † 6/2015 Christ F21V 21/04
9,065,264 B2 * 6/2015 Cooper H02G 3/20
9,068,719 B2 † 6/2015 Van De Ven F21V 29/773
9,068,722 B2 * 6/2015 Wronski F21V 17/02
D735,012 S † 7/2015 Cowie D8/107
D735,142 S † 7/2015 Hagarty D13/15
9,078,299 B2 † 7/2015 Ashdown H05B 47/00
9,109,783 B1 8/2015 Davis et al.
D739,355 S * 9/2015 D'Aubeterre D13/139.8
D739,590 S † 9/2015 Redfern D26/74
9,140,441 B2 † 9/2015 Goelz F21V 29/763
D741,538 S 10/2015 Ghasabi
9,151,457 B2 † 10/2015 Pickard F21S 8/026
9,151,477 B2 † 10/2015 Pickard F21S 8/026
D742,325 S † 11/2015 Leung D13/152
D743,079 S 11/2015 Adair
D744,723 S 12/2015 Yoo
9,217,560 B2 † 12/2015 Harbers F21V 29/00
9,222,661 B2 † 12/2015 Kim F21V 23/006
9,239,131 B1 1/2016 Wronski et al.
D750,317 S 2/2016 Lui et al.
9,281,671 B2 † 3/2016 Sathyanarayana H02G 3/08
9,285,103 B2 † 3/2016 Van De Ven F21V 15/01
9,291,319 B2 † 3/2016 Kathawate F21S 8/026
9,301,362 B2 † 3/2016 Dohn H05B 45/00
D754,078 S 4/2016 Baldwin et al.
D754,079 S 4/2016 Baldwin et al.
D754,605 S 4/2016 McMillan
9,303,812 B2 4/2016 Green et al.
9,310,038 B2 † 4/2016 Athalye F21V 3/04
9,322,543 B2 † 4/2016 Hussell H01K 1/00
9,347,655 B2 † 5/2016 Boomgaarden F21V 21/30
9,366,418 B2 6/2016 Gifford
9,371,966 B2 † 6/2016 Rowlette, Jr F21K 9/00
D762,181 S † 7/2016 Lin F21V 29/83
D13/17
9,395,051 B2 † 7/2016 Hussell F21V 13/14
D762,906 S † 8/2016 Jeswani D26/74
D764,079 S † 8/2016 Wu D26/24
9,404,639 B2 8/2016 Bailey et al.
9,417,506 B1 † 8/2016 Tirosh G03B 15/06
9,423,110 B1 8/2016 Newton et al.
D766,185 S † 9/2016 Hagarty D13/15
D767,199 S 9/2016 Wronski et al.
9,447,917 B1 9/2016 Wronski et al.
9,447,953 B2 9/2016 Lawlor
D768,325 S † 10/2016 Xu D26/74
D768,326 S † 10/2016 Guzzini D26/74
D769,501 S † 10/2016 Jeswani D26/74
D770,065 S † 10/2016 Tittle D26/24
D770,076 S 10/2016 Li et al.
9,476,552 B2 † 10/2016 Myers F21S 8/026
D774,676 S 12/2016 Ng
D776,324 S † 1/2017 Gierl D26/74
9,534,751 B2 † 1/2017 Maglica F21V 19/005
D778,241 S † 2/2017 Holbrook D13/15
D778,484 S † 2/2017 Guzzini D26/74
9,581,302 B2 † 2/2017 Danesh F21V 21/04
9,599,315 B1 † 3/2017 Harpenau F21V 21/04
9,605,842 B1 3/2017 Davis
9,605,910 B2 † 3/2017 Swedberg F21V 23/026
D785,228 S † 4/2017 Guzzini D26/74
D786,472 S † 5/2017 Redfern D26/74
D786,473 S 5/2017 Dean
D786,474 S † 5/2017 Fujisawa D26/74
D788,330 S † 5/2017 Johnson D26/2
D790,102 S † 6/2017 Guzzini D26/74
9,673,597 B2 † 6/2017 Lee H02G 3/121
9,689,541 B2 6/2017 Wronski
D791,709 S 7/2017 Holton
D791,711 S † 7/2017 Holton D13/152
D791,712 S 7/2017 Holton
D791,996 S † 7/2017 Holscher D26/74
9,696,021 B2 7/2017 Wronski
9,702,516 B1 † 7/2017 Vasquez F21V 21/04
D795,820 S 8/2017 Wengreen
9,732,904 B1 8/2017 Wronski
9,732,947 B1 8/2017 Christ et al.
9,739,464 B2 8/2017 Wronski
D799,105 S 10/2017 Eder et al.
D800,957 S 10/2017 Eder et al.
9,791,111 B1 † 10/2017 Huang F21K 9/20
9,797,562 B2 10/2017 Dabiet et al.
9,803,839 B2 † 10/2017 Visser F21V 29/507
D805,660 S † 12/2017 Creasman D26/2
9,854,642 B2 12/2017 Kashani
D809,176 S † 1/2018 Partington D26/74
9,860,961 B2 1/2018 Chemel et al.
9,863,619 B2 † 1/2018 Mak F21V 23/002

(56)

References Cited

U.S. PATENT DOCUMENTS

D809,465 S 2/2018 Keirstead
 9,903,569 B2 2/2018 O'Brien et al.
 9,945,548 B2 4/2018 Williams et al.
 9,964,266 B2 ‡ 5/2018 Danesh F21V 7/041
 D820,494 S ‡ 6/2018 Cohen D26/74
 D821,615 S 6/2018 Trice
 D821,627 S 6/2018 Ko
 9,995,441 B2 ‡ 6/2018 Power F21V 7/043
 D822,505 S 7/2018 Gibson et al.
 D824,494 S 7/2018 Martins et al.
 D825,829 S 8/2018 Guo
 10,041,638 B2 8/2018 Vasquez et al.
 10,054,274 B2 8/2018 Athalye et al.
 D827,903 S 9/2018 Wu
 10,072,805 B2 9/2018 Bailey
 D832,218 S * 10/2018 Wronski D13/152
 D833,977 S * 11/2018 Danesh D13/152
 10,125,959 B2 11/2018 Cohen
 10,139,059 B2 * 11/2018 Danesh F21V 21/048
 D836,976 S 1/2019 Reese et al.
 10,244,607 B1 3/2019 Kashani
 D847,414 S 4/2019 Danesh et al.
 D847,415 S 4/2019 Danesh et al.
 10,247,390 B1 4/2019 Kopitzke et al.
 D848,375 S * 5/2019 Danesh D13/152
 10,281,131 B2 5/2019 Cohen
 10,295,163 B1 * 5/2019 Cohen H02G 3/20
 D850,695 S 6/2019 Dabiet et al.
 D851,046 S * 6/2019 Peng D13/152
 10,408,395 B2 9/2019 Danesh
 10,408,396 B2 * 9/2019 Wronski F21V 21/048
 10,408,436 B2 9/2019 Wronski et al.
 D863,661 S 10/2019 Tian et al.
 D864,877 S 10/2019 Danesh et al.
 D867,653 S 11/2019 Gorman
 10,488,000 B2 11/2019 Danesh et al.
 10,551,044 B2 * 2/2020 Peng F21V 17/18
 10,563,850 B2 2/2020 Danesh
 D877,957 S 3/2020 Kopitzke, IV
 10,591,120 B2 3/2020 Bailey et al.
 10,609,785 B1 3/2020 Fardadi et al.
 D880,733 S 4/2020 Lo et al.
 D883,562 S 5/2020 Hu
 D885,648 S 5/2020 Zeng
 D885,649 S 5/2020 McLaughlin, III et al.
 10,663,127 B2 5/2020 Danesh et al.
 10,663,153 B2 5/2020 Nikooyan et al.
 D888,313 S 6/2020 Xie et al.
 10,683,994 B2 * 6/2020 Wronski F21V 23/00
 10,684,003 B2 * 6/2020 Wronski F21V 15/01
 D890,410 S 7/2020 Stanford et al.
 10,704,745 B2 7/2020 Sherry et al.
 10,753,558 B2 * 8/2020 Danesh F21V 15/01
 10,808,917 B2 10/2020 Harris et al.
 10,816,148 B2 10/2020 Danesh
 D901,398 S * 11/2020 Danesh D13/152
 D901,745 S 11/2020 Yang
 D902,160 S * 11/2020 Cohen D13/152
 D902,871 S * 11/2020 Danesh D13/152
 D903,605 S * 12/2020 Danesh D13/152
 D905,327 S 12/2020 Williams et al.
 D907,284 S 1/2021 Danesh et al.
 D910,223 S 2/2021 Cohen
 10,975,570 B2 4/2021 Shen
 10,982,829 B2 4/2021 Danesh
 11,022,259 B2 6/2021 Bailey et al.
 11,028,982 B2 6/2021 Danesh
 11,047,538 B2 6/2021 Danesh et al.
 D924,467 S 7/2021 Danesh et al.
 D925,109 S 7/2021 Danesh et al.
 11,060,705 B1 7/2021 Danesh et al.
 11,067,231 B2 7/2021 Lotfi et al.
 11,085,597 B2 8/2021 Danesh
 2002/0172047 A1 ‡ 11/2002 Ashley F21S 8/02
 362/36

2003/0006353 A1 * 1/2003 Dinh B60N 2/073
 248/343
 2003/0016532 A1 1/2003 Reed
 2003/0021104 A1 1/2003 Tsao
 2003/0161153 A1 8/2003 Patti
 2004/0001337 A1 ‡ 1/2004 Defouw F21S 8/02
 362/15
 2004/0120141 A1 6/2004 Beadle
 2004/0156199 A1 8/2004 Rivas et al.
 2005/0078474 A1 4/2005 Whitfield
 2005/0121215 A1 6/2005 Halbert
 2005/0225966 A1 ‡ 10/2005 Hartmann F21S 8/02
 362/14
 2005/0227536 A1 ‡ 10/2005 Gamache F21S 8/02
 439/60
 2005/0231962 A1 10/2005 Koba et al.
 2005/0237746 A1 ‡ 10/2005 Yiu F21S 8/02
 362/29
 2006/0005988 A1 1/2006 Jorgensen
 2006/0158873 A1 ‡ 7/2006 Newbold F21S 8/02
 362/14
 2006/0198126 A1 9/2006 Jones
 2006/0215408 A1 ‡ 9/2006 Lee F21V 9/08
 362/29
 2006/0221620 A1 10/2006 Thomas
 2006/0237601 A1 10/2006 Rinderer
 2006/0243877 A1 11/2006 Rippel
 2006/0250788 A1 11/2006 Hodge et al.
 2006/0262536 A1 11/2006 Nevers
 2006/0262545 A1 11/2006 Piepgras et al.
 2007/0012847 A1 1/2007 Tai
 2007/0035951 A1 ‡ 2/2007 Tseng F21V 33/0044
 362/29
 2007/0121328 A1 5/2007 Mondloch et al.
 2007/0131827 A1 6/2007 Nevers et al.
 2007/0185675 A1 ‡ 8/2007 Papamichael H05B 47/125
 702/85
 2007/0200039 A1 8/2007 Petak
 2007/0206374 A1 ‡ 9/2007 Petrakis F21S 8/02
 362/14
 2008/0002414 A1 1/2008 Miletich et al.
 2008/0112168 A1 ‡ 5/2008 Pickard F21S 8/026
 362/24
 2008/0112170 A1 ‡ 5/2008 Trott F21S 8/02
 362/31
 2008/0112171 A1 ‡ 5/2008 Patti F21V 21/30
 362/36
 2008/0130308 A1 6/2008 Behr et al.
 2008/0137347 A1 ‡ 6/2008 Trott F21S 8/02
 362/31
 2008/0165545 A1 ‡ 7/2008 O'Brien F21S 8/02
 362/36
 2008/0170404 A1 7/2008 Steer et al.
 2008/0224008 A1 9/2008 Dal Ponte et al.
 2008/0232116 A1 ‡ 9/2008 Kim F21S 8/026
 362/36
 2008/0247181 A1 10/2008 Dixon
 2008/0285271 A1 11/2008 Roberge et al.
 2009/0003009 A1 ‡ 1/2009 Tessnow F21S 41/151
 362/48
 2009/0034261 A1 ‡ 2/2009 Grove F21S 8/02
 362/29
 2009/0080189 A1 ‡ 3/2009 Wegner F21S 8/02
 362/23
 2009/0086484 A1 ‡ 4/2009 Johnson F21S 8/02
 362/23
 2009/0097262 A1 4/2009 Zhang et al.
 2009/0135613 A1 ‡ 5/2009 Peng F21K 9/233
 362/37
 2009/0141500 A1 ‡ 6/2009 Peng F21K 9/233
 362/29
 2009/0141506 A1 ‡ 6/2009 Lan F21S 8/02
 362/35
 2009/0141508 A1 ‡ 6/2009 Peng F21V 23/02
 362/37
 2009/0147517 A1 ‡ 6/2009 Li F21V 21/046
 362/24

(56)		References Cited							
U.S. PATENT DOCUMENTS									
2009/0161356	A1 †	6/2009	Negley	F21K 9/233	2012/0074852	A1 †	3/2012	Delnoij	H05B 47/11
				362/23					315/15
2009/0237924	A1 †	9/2009	Ladewig	F21S 2/005	2012/0106176	A1 †	5/2012	Lopez	F21K 9/00
				362/23					362/38
2009/0280695	A1 †	11/2009	Sekela	F21V 21/002	2012/0113642	A1 †	5/2012	Catalano	F21V 23/001
				439/69					362/24
2009/0283292	A1	11/2009	Lehr		2012/0140442	A1 †	6/2012	Woo	F21V 7/04
2009/0290343	A1 †	11/2009	Brown	F21K 9/00					362/95
				362/23	2012/0140465	A1	6/2012	Rowlette, Jr. et al.	
2010/0014282	A1 †	1/2010	Danesh	F21S 8/02	2012/0162994	A1 †	6/2012	Wasniewski	F21S 8/026
				362/14					362/29
2010/0033095	A1	2/2010	Sadwick		2012/0182744	A1 †	7/2012	Santiago	F21S 8/026
2010/0061108	A1 †	3/2010	Zhang	F21S 8/026					362/36
				362/36	2012/0188762	A1 †	7/2012	Joung	F21V 15/01
2010/0110690	A1 †	5/2010	Hsu	G02F 1/133516					362/23
				362/29	2012/0243237	A1 †	9/2012	Toda	F21V 23/006
2010/0110698	A1 †	5/2010	Harwood	F21V 21/04					362/30
				362/36	2012/0250321	A1	10/2012	Blincoe et al.	
2010/0110699	A1	5/2010	Chou		2012/0266449	A1	10/2012	Krupa	
2010/0148673	A1 †	6/2010	Stewart	H05B 45/37	2012/0268688	A1	10/2012	Sato et al.	
				315/12	2012/0287625	A1 †	11/2012	Macwan	F21S 8/026
2010/0149822	A1 †	6/2010	Cogliano	F21S 8/02					362/23
				362/36	2012/0305868	A1	12/2012	Callahan et al.	
2010/0165643	A1	7/2010	Russo et al.		2012/0314429	A1	12/2012	Plunk	
2010/0244709	A1 †	9/2010	Steiner	G01J 1/02	2013/0009552	A1 †	1/2013	Page	H05B 47/11
				315/15					315/15
2010/0246172	A1 †	9/2010	Liu	F21V 23/026	2013/0010476	A1 †	1/2013	Pickard	F21S 8/026
				362/23					362/31
2010/0259919	A1 †	10/2010	Khazi	F21V 29/505	2013/0016864	A1	1/2013	Ivey et al.	
				362/84	2013/0033872	A1 †	2/2013	Randolph	F21K 9/00
2010/0270903	A1 †	10/2010	Jao	F21V 21/04					362/29
				313/46	2013/0050994	A1	2/2013	Pieper	
2010/0277905	A1	11/2010	Janik et al.		2013/0051012	A1 †	2/2013	Oehle	F21S 8/026
2010/0284185	A1	11/2010	Ngai						362/23
2010/0302778	A1 †	12/2010	Dabiet	F21S 8/02	2013/0077307	A1	3/2013	Yamamoto	
				362/24	2013/0083529	A1	4/2013	Gifford	
2010/0328956	A1	12/2010	Zhang		2013/0141913	A1 †	6/2013	Sachsenweger	F21V 29/77
2011/0043040	A1 †	2/2011	Porter	H02J 7/0024					362/24
				307/66	2013/0155681	A1	6/2013	Nall et al.	
2011/0063831	A1 †	3/2011	Cook	F21S 8/02	2013/0163254	A1 †	6/2013	Chang	F21V 17/105
				362/23					362/29
2011/0068687	A1 †	3/2011	Takahasi	F21V 3/00	2013/0170232	A1	7/2013	Park et al.	
				315/35	2013/0170233	A1 †	7/2013	Nezu	H01R 33/465
2011/0069499	A1 †	3/2011	Trott	F21S 8/026					362/36
				362/36	2013/0227908	A1	9/2013	Gulbrandsen et al.	
2011/0080750	A1 †	4/2011	Jones	F21V 21/048	2013/0258677	A1 †	10/2013	Fryzek	F21S 8/026
				362/43					362/32
2011/0116276	A1 †	5/2011	Okamura	F21V 21/04	2013/0265750	A1 †	10/2013	Pickard	F21L 4/02
				362/40					362/18
2011/0121756	A1	5/2011	Thomas et al.		2013/0271989	A1 †	10/2013	Hussell	F21V 29/004
2011/0134634	A1 †	6/2011	Gingrich, III	F21V 29/773					362/24
				362/23	2013/0294084	A1 †	11/2013	Kathawate	F21S 8/026
2011/0134651	A1 †	6/2011	Berman	F21S 8/02					362/29
				362/36	2013/0301252	A1 †	11/2013	Hussell	F21K 9/232
2011/0140633	A1	6/2011	Archenhold						362/18
2011/0170294	A1 †	7/2011	Mier-Langner	F21S 8/02	2013/0322062	A1 †	12/2013	Danesh	F21V 21/04
				362/29					362/15
2011/0194299	A1 †	8/2011	Crooks	F21V 21/04	2013/0322084	A1	12/2013	Ebisawa	
				362/42	2013/0335980	A1 †	12/2013	Nakasuji	F21S 8/026
2011/0216534	A1 †	9/2011	Tickner	F21S 8/02					362/34
				362/23	2014/0029262	A1	1/2014	Maxik et al.	
2011/0226919	A1 †	9/2011	Fryzek	F21S 8/026	2014/0036497	A1 †	2/2014	Hussell	F21V 29/004
				248/29					362/23
2011/0255292	A1 †	10/2011	Shen	F21V 15/01	2014/0049957	A1 †	2/2014	Goelz	F21V 29/763
				362/31					362/23
2011/0267828	A1 †	11/2011	Bazydola	F21V 29/004	2014/0063776	A1 †	3/2014	Clark	F21V 23/008
				362/37					362/20
2011/0285314	A1 †	11/2011	Carney	E04B 9/006	2014/0071679	A1 †	3/2014	Booth	F21V 29/2212
				315/29					362/24
2012/0020104	A1 †	1/2012	Biebl	F21S 45/48	2014/0071687	A1 †	3/2014	Tickner	F21V 21/03
				362/54					362/29
					2014/0140490	A1 †	5/2014	Roberts	H04M 3/42357
									379/88
					2014/0063818	A1 †	6/2014	Randolph	F21V 7/0091
									362/31
					2014/0233246	A1	8/2014	Lafreniere et al.	

(56)

References Cited

FOREIGN PATENT DOCUMENTS

U.S. PATENT DOCUMENTS				FOREIGN PATENT DOCUMENTS			
2014/0254177	A1 ‡	9/2014	Danesh F21V 21/30 362/36	CA	2691480	C	4/2012
2014/0268836	A1	9/2014	Thompson	CA	2734369	A1	10/2013
2014/0268869	A1	9/2014	Blessitt et al.	CA	2561459	A1	11/2013
2014/0299730	A1	10/2014	Green et al.	CA	2815067	‡	11/2013
2014/0313775	A1	10/2014	Myers et al.	CA	2848289	A1	10/2014
2014/0321122	A1 ‡	10/2014	Domagala F21K 9/233 362/29	CA	2998173		7/2018
2014/0347848	A1 ‡	11/2014	Pisavadia F21S 8/06 362/19	CN	2182475	Y	11/1994
2015/0009676	A1 ‡	1/2015	Danesh H04R 17/00 362/36	CN	201059503	Y	5/2008
2015/0029732	A1	1/2015	Hatch	CN	201259125	Y ‡	6/2009
2015/0078008	A1	3/2015	He	CN	101608781	A ‡	12/2009
2015/0085500	A1	3/2015	Cooper et al.	CN	201636626	U ‡	11/2010
2015/0131301	A1	5/2015	Ho	CN	102062373	A	5/2011
2015/0138779	A1 ‡	5/2015	Livesay F21S 8/026 362/29	CN	202014067	U	10/2011
2015/0153635	A1	6/2015	Chen et al.	CN	202392473	U ‡	8/2012
2015/0184837	A1 ‡	7/2015	Zhang F21V 29/70 362/29	CN	202733693	U ‡	2/2013
2015/0198324	A1 ‡	7/2015	O'Brien F21V 29/70 362/29	CN	103307518	A ‡	9/2013
2015/0219317	A1	8/2015	Gatof et al.	CN	103322476	A ‡	9/2013
2015/0233556	A1 *	8/2015	Danesh F21V 21/048 362/365	CN	203202661	U	9/2013
2015/0241039	A1	8/2015	Fryzek	CN	203215483	U ‡	9/2013
2015/0263497	A1 ‡	9/2015	Korcz H02G 3/086 220/3	CN	101498411	B ‡	11/2013
2015/0276185	A1 ‡	10/2015	Bailey F21V 13/04 362/29	CN	203273663	U	11/2013
2015/0308662	A1	10/2015	Vice et al.	CN	203297980	U ‡	11/2013
2015/0345761	A1	12/2015	Lawlor	CN	203628464	U	12/2013
2015/0362159	A1 ‡	12/2015	Ludyjan F21V 23/06 362/27	CN	203628464	U ‡	6/2014
2016/0084488	A1	3/2016	Wu et al.	CN	203641919	U ‡	6/2014
2016/0209007	A1	7/2016	Belmonte et al.	CN	204300818	U	4/2015
2016/0238225	A1	8/2016	Doust	CN	104654142	A ‡	5/2015
2016/0308342	A1	10/2016	Witherbee et al.	CN	204513161	U ‡	7/2015
2016/0312987	A1 ‡	10/2016	Danesh F21S 8/026	CN	204611541	U ‡	9/2015
2016/0348860	A1 ‡	12/2016	Bailey F21S 8/024	CN	204786225	U	11/2015
2016/0348861	A1 ‡	12/2016	Bailey F21S 8/026	CN	204829578	U ‡	12/2015
2016/0366738	A1 ‡	12/2016	Boulanger F21S 9/02	CN	103712135	B ‡	4/2016
2017/0003007	A1	1/2017	Wronski	CN	205606362	U ‡	9/2016
2017/0045213	A1 ‡	2/2017	Williams F21V 23/06	CN	206130742	U	4/2017
2017/0059135	A1 ‡	3/2017	Jones F21V 7/00	CN	2016130742	U ‡	4/2017
2017/0138576	A1 *	5/2017	Peng F21V 23/001	CN	103154606	B ‡	5/2017
2017/0138581	A1 ‡	5/2017	Rashidi Doust F21V 25/125	CN	206222112	U	6/2017
2017/0167672	A1	6/2017	Stauner et al.	CN	107013845	A	8/2017
2017/0167699	A1 *	6/2017	Schubert F21S 8/026	CN	107084343	A	8/2017
2017/0198896	A1	7/2017	May	DE	9109828	U1 ‡	2/1992
2017/0284616	A1	10/2017	Coakley et al.	DE	199 47 208		5/2001
2017/0307188	A1 ‡	10/2017	Oudina F21V 21/048	EP	1 589 289		10/2005
2017/0307198	A1	10/2017	Shah et al.	EP	1 672 155	A1 ‡	6/2006
2018/0112857	A1	4/2018	Wronski et al.	EP	1688663		8/2006
2018/0142871	A1	5/2018	Morales	EP	2 095 938	A1 ‡	2/2008
2018/0216809	A1	8/2018	Cohen	EP	2 306 072	A1 ‡	4/2011
2018/0224095	A1	8/2018	Cohen	EP	2 453 169	A2 ‡	5/2012
2018/0283677	A1	10/2018	Cohen	EP	2 193 309	81 ‡	7/2012
2019/0032874	A1	1/2019	Bonnetto et al.	EP	2 193 309	B1	7/2012
2019/0041050	A1	2/2019	Cairns et al.	EP	2 735 787	A1	5/2014
2019/0049080	A1	2/2019	Danesh	EP	3 104 024	A1	12/2016
2019/0063701	A1 *	2/2019	Lotfi F21S 9/022	GB	2325728		12/1998
2019/0093836	A1	3/2019	Danesh	GB	2427020	A	12/2006
2020/0182420	A1 *	6/2020	Cohen H02G 3/20	GB	2466875		7/2010
2020/0291652	A1 *	9/2020	Shen H02G 3/20	GB	2471929		1/2014
2020/0355334	A1	11/2020	Shen et al.	GB	2509772	A ‡	7/2014
2020/0393118	A1 *	12/2020	Danesh F21V 17/18	JP	H02113002	U	9/1990
2021/0010647	A1	1/2021	Danesh et al.	JP	2007091052	A	4/2007
2021/0010663	A1	1/2021	Nikooyan et al.	JP	2007265961	A ‡	10/2007
2021/0033268	A1	2/2021	Danesh	JP	2011060450	A2 ‡	3/2011
2021/0080081	A1	3/2021	Cohen	JP	2012064551	A2 ‡	3/2012
2021/0080084	A1	3/2021	Danesh et al.	JP	2015002027	A2 ‡	1/2015
2021/0222845	A1	7/2021	Kopitzke et al.	JP	2015002028	A2 ‡	1/2015
				JP	2016219335	A	12/2016
				JP	2017107699	A2	6/2017
				JP	20171076699	A2 ‡	6/2017
				KR	1020110008796	A ‡	1/2011
				KR	1020120061625	A ‡	6/2012
				MX	2011002947	A	9/2011
				TW	474382	U	1/2002
				WO	WO 2013/128896	A1 ‡	9/2013
				WO	WO 2015/000212	A1 ‡	1/2015

(56)

References Cited

FOREIGN PATENT DOCUMENTS

WO WO 2016/152116 A2 † 9/2016
 WO WO 2016152166 A2 9/2016

OTHER PUBLICATIONS

Non-Final Office Action dated Sep. 5, 2014 from U.S. Appl. No. 13/791,087, 8 pages.†

Non-Final Office Action dated Dec. 15, 2016 from U.S. Appl. No. 14/184,601, 18 pages.†

Non-Final Office Action mailed Feb. 6, 2018 from U.S. Appl. No. 15/167,682, 9 pages.†

Non-Final Office Action mailed Sep. 15, 2015 from U.S. Appl. No. 13/484,901, 16 pages.†

“Metallic and Non-metallic Outlet Boxes Used in Fire-rated Assembly,” <https://iaeimagazine.org/magazine/2000/09/16/metallic-and-non-metallic-outlet-boxes-used-in-fire-rated-assembly/>, Sep. 16, 2000, 5 pages.†

Non-Final Office Action mailed Mar. 15, 2010 from U.S. Appl. No. 12/100,148, 8 pages.†

Non-Final Office Action mailed Apr. 30, 2010 from U.S. Appl. No. 12/173,232, 13 pages.†

“Membrane Penetrations in Fire-Resistance Rated Walls,” https://www.ul.com/wp-content/uploads/2014/04/ul_MembranePenetrations.pdf, Issue 1, 2009, 2 pages.†

“Metallic Outlet Boxes,” UI 514A, Underwriters Laboratories, Inc., Feb. 16, 2004 (Title Page Reprinted Aug. 10, 2007), 106 pages.†

Notice of Allowance mailed Jan. 16, 2015 from U.S. Appl. No. 29/467,026, 9 pages.†

Notice of Allowance mailed Oct. 21, 2016 from U.S. Appl. No. 13/484,901, 7 pages.†

Notice of Allowance mailed Mar. 24, 2016 from U.S. Appl. No. 14/247,149, 8 pages.†

Notice of Allowance mailed Aug. 23, 2017 from Canadian Application No. 2,879,629, 1 page (Atty. Docket No. DMFI-001/01CA).†

“Outlet Boxes for Use in Fire Rated Assemblies,” https://www.ul.com/wp-content/uploads/2014/04/UI_outletboxes.pdf, 2011, 2 pages.†

DME Series Installation Instructions, Oct. 18, 2011, 2 pages.†

Non-Final Office Action mailed May 17, 2017 from U.S. Appl. No. 14/183,424, 20 pages.†

Non-Final Office Action mailed Jun. 2, 2015 from U.S. Appl. No. 14/183,424, 20 pages.†

Notice of Allowance mailed Jan. 30, 2015 from U.S. Appl. No. 13/791,087, 9 pages.†

Non-Final Office Action mailed Oct. 16, 2014 from U.S. Appl. No. 13/484,901, 11 pages.†

Non-Final Office Action mailed Sep. 6, 2017 from U.S. Appl. No. 14/726,064, 8 pages.†

Dmf, Inc., “dmf Ighiing: Led Recessed Downlighting,” Product Catalog, Aug. 2012, 68 pages.†

Final Office Action mailed Apr. 27, 2016 from U.S. Appl. No. 14/184,601, 19 pages.†

Final Office Action mailed Jul. 26, 2017 from U.S. Appl. No. 14/184,601, 18 pages.†

Dmf, Inc., “dmf LIGHTING: LED Recessed Lighting Solutions,” Info sheets, Mar. 15, 2012, 4 pages.†

Halo, Halo Led H4 H7 Collection, SustainableDesign, Cooper Lighting, (emphasis on p. 18 “H7 Collection LED Modules - Halo Led H7 Module Features,”) Mar. 28, 2012, 52 p.†

Halo, H7LED Downlight Trims 49x Series, 6-inchLED Trims for Use with M17x LED Modules, Cooper Lighting, ADV110422, rev. Aug. 12, 2011, 15 pages.†

Halo, Led Module ML706x, Cooper Lighting, General Installation for All Modules/p. 1; Tether Installation/pp. 2-3; Installation into HALO H750x Series LED - only (Non-Screw Based), Recessed Fixture, p. 4, Oct. 20, 2009, 4 p. †

Final Office Action mailed Jan. 29, 2016 from U.S. Appl. No. 14/183,424, 21 pages.†

Final Office Action mailed Jun. 23, 2016 from U.S. Appl. No. 13/484,901, 18 pages.†

Final Office Action mailed Apr. 2, 2015 from U.S. Appl. No. 13/484,901, 13 pages.†

Canadian Office Action dated Dec. 6, 2016 from Canadian Application No. 2,879,629, 3 pages (Atty. Docket No. DMFI-001/01CA).†

Canadian Office Action dated Mar. 9, 2017 from Canadian Application No. 2,931,588, 5 pages (Atty. Docket No. DMFI-002/01CA).†

Canadian Office Action dated Feb. 1, 2016 from Canadian Application No. 2,879,486, 5 pages (Atty. Docket No. DMFI-003/OOCA).†

Canadian Office Action dated Jun. 12, 2017 from Canadian Application No. 2,927,601, 4 pages (Atty. Docket No. DMFI-004/OOCA).†

Canadian Office Action dated Aug. 11, 2017 from Canadian Application No. 2,941,051, 4 pages (Atty. Docket No. DMFI-005/OOCA).†

Ceyy.Guideinfo, Outlet Boxes and Fittings Certified for Fire Resistance, UL Online Certifications Directory, last updated 2013-05-16, 2 pages.†

Canadian Office Action dated Dec. 23, 2013 from Canadian Application No. 2,778,581, 3 pages.†

Canadian Office Action dated Mar. 22, 2016 from Canadian Application No. 2,879,629, 4 pages (Atty. Docket No. DMFI-001/01CA).†

2006 International Building Code, Section 712 Penetrations, 2006, 4 pages.†

Bxuv.GuideInfo, Fire Resistance Ratings - ANSI/UL 263, UL Online Certifications Directory, last updated 2016-11-03, 27 pages.†

Notice of Allowance mailed May 10, 2018 from U.S. Appl. No. 14/726,064, 7 pages.†

Non-Final Office Action mailed May 16, 2018 for U.S. Appl. No. 15/132,875, 18 pages.†

International Search Report and Written Opinion in PCT/US2018/048357 mailed Nov. 14, 2018 (Atty. Docket No. DMFI-007W001), 13 pages.†

Non-Final Office Action mailed Oct. 24, 2018 for U.S. Appl. No. 15/688,266, 14 pages.†

Non-Final Office Action mailed Dec. 5, 2018 from U.S. Appl. No. 14/942,937, 13 pages.†

International Search Report and Written Opinion in International Patent Application No. PCT/US18/39048 mailed Dec. 14, 2018 (Atty. Docket No. DMFI-014W001). 24 pages.†

Notice of Allowance mailed Oct. 9, 2018 from U.S. Appl. No. 29/653,142, 7 pages.†

Notice of Allowance dated Sep. 19, 2018 from U.S. Appl. No. 15/167,682, 7 pages.†

Notice of Allowance dated Oct. 4, 2018 from U.S. Appl. No. 15/947,065, 9 pages.†

Notice of Allowance dated Nov. 27, 2018 from U.S. Appl. No. 15/167,682, 11 pages.†

“Portland Bi-Color, Warm White/Red,” item: 1LIM30941.1mtra Marine Products. 2012. 3 pages.†

“LED Undercabinet Pocket Guide,” ELCO Lighting. 12 pages.†

“VERSI LED Mini Flush,” Lithonia Lighting. 6 pages.†

Carlson® Zip Box® Blue™ Switch and Outlet Boxes, Product Brochure, <http://www.carlonsales.com/brochures.php>, 2006, 22 pages.†

“Undercabinet Pucks, Xyris Mini LED Puck Light,” ELCO Lighting. Sep. 2018. 1 page.†

“Cree LMH2 LED Modules Design Guide,” Cree Product Design Guide. 2011. 20 pages.†

“Cree LMH2 LED Modules,” Mouser Electronics. 2 pages.†

“Cree LMH2 LED Module with TrueWhite Technology,” Cree Product Family Data Sheet. 2011. 3 pages.†

“Advanced LED Solutions,” Imtra Marine Lighting. 2011. 39 pages.†

Notice of Allowance dated May 22, 2018 from U.S. Appl. No. 14/183,424, 9 pages.†

Notice of Allowance dated Mar. 26, 2018 for U.S. Appl. No. 14/184,601, 10 pages.†

(56)

References Cited

OTHER PUBLICATIONS

Non-Final Office Action dated Apr. 12, 2018 for U.S. Appl. No. 29/638,259, 5 pages.‡

<<https://www.zhagastandard.org/books/book18/>>, Mar. 2017, 5 pages.‡

Acrich COB Zhaga Module, Product Description, Seoul Semiconductor, Nov. 2016, 39 pages.‡

RACO 4 in. Octagon Welded Concrete Ring, 6 in. Deep with 1/2 and 3/4 in. Knockouts (10-Pack). Model # 276. Accessed at <https://www.homedepot.com/p/RACO-4-in-Octagon-Welded-Concrete-Ring-6-in-Deep-with-1-2-and-3-4-in-Knockouts-10-Pack-276/203638675> on Jan. 16, 2019. 4 pages.‡

RACO 4 in. Octagon Welded Concrete Ring, 3-1/2 in. Deep with 1/2 and 3/4 in. Knockouts and includes 890 cover (20-Pack). Model # 280. Accessed at <https://www.homedepot.com/p/RACO-4-in-Octagon-Welded-Concrete-Ring-3-1-2-in-Deep-with-1-2-and-3-4-in-Knockouts-and-includes-890-cover-20-Pack-280/203638679> on Jan. 18, 2019. 3 pages.‡

Dmflighting.com: OneFrame Recessed LED Downlight. Published Jun. 6, 2018. Retrieved from the internet at <https://www.dmflighting.com/product/oneframe/>, Jun. 6, 2018. 11 pages. (Year: 2018).‡

U.S. Appl. No. 15/637,742, filed Jun. 29, 2017, Kopitzke, IV.

U.S. Appl. No. 15/688,266, filed Aug. 28, 2017, Lofti et al.

U.S. Appl. No. 15/853,400, filed Dec. 22, 2017, Kashani.

U.S. Appl. No. 15/901,738, filed Feb. 21, 2018, Danesh.

U.S. Appl. No. 15/947,065, filed Apr. 6, 2018, Danesh.

U.S. Appl. No. 16/016,040, filed Jun. 22, 2018, Danesh.

U.S. Appl. No. 16/200,393, filed Nov. 26, 2018, Danesh.

U.S. Appl. No. 29/638,259, filed Feb. 26, 2018, Danesh.

U.S. Appl. No. 29/541,565, filed Oct. 5, 2015, Peng.

U.S. Appl. No. 29/645,941, filed Apr. 30, 2018, Danesh et al.

U.S. Appl. No. 29/653,142, filed Jun. 11, 2018, Danesh et al.

U.S. Appl. No. 29/644,471, filed Sep. 25, 2018, Danesh et al.

U.S. Appl. No. 29/678,478, filed Jan. 29, 2019, Danesh et al.

U.S. Appl. No. 29/678,482, filed Jan. 29, 2019, Danesh et al.

U.S. Appl. No. 29/683,730, filed Mar. 15, 2019, Danesh et al.

U.S. Appl. No. 16/653,497, filed Oct. 15, 2019, Danesh et al.

U.S. Appl. No. 29/711,198, filed Nov. 29, 2019, Danesh et al.

U.S. Appl. No. 16/690,970, filed Nov. 21, 2019, Nikooyan et al.

U.S. Appl. No. 16/719,361, filed Dec. 18, 2019, Danesh et al.

U.S. Appl. No. 16/522,275, filed Jul. 25/201, Danesh.

U.S. Appl. No. 16/725,606, filed Dec. 23, 2019, Bailey et al.

“Outlet Boxes for Use in Fire Rated Assemblies,” https://www.ul.com/wp-content/uploads/2014/04/UI_outletboxes.pdf, 2011, 2 pages.

“Portland Bi-Color, Warm White/Red,” item:ILIM30941.Imtra Marine Products. 2012. 3 pages.

<<https://www.zhagastandard.org/books/book18/>>, Mar. 2017, 5 pages.

4" Octagon Concrete Boxes and Back Plates. Appleton. Accessed at www.appletonelec.com on May 6, 2019. 1 page.

Be seen in the best light. Lightolier by signify. Comprehensive 2019 Lighting Catalog. 114 pages.

BXUV.GuideInfo, Fire Resistance Ratings—ANSI/UL 263, UL Online Certifications Directory, last updated Nov. 3, 2016, 27 pages.

Canadian Office Action dated Aug. 11, 2017 from Canadian Application No. 2,941,051, 4 pages.

Canadian Office Action dated Dec. 6, 2016 from Canadian Application No. 2,879,629, 3 pages.

Canadian Office Action dated Feb. 1, 2016 from Canadian Application No. 2,879,486, 5 pages.

Canadian Office Action dated Jun. 12, 2017 from Canadian Application No. 2,927,601, 4 pages.

Canadian Office Action dated Mar. 22, 2016 from Canadian Application No. 2,879,629, 4 pages.

Canadian Office Action dated Mar. 9, 2017 from Canadian Application No. 2,931,588, 5 pages.

Carlson® Zip Box® Blue™ Switch and Outlet Boxes, Product Brochure, <http://www.carlonsales.com/brochures.php>, 2006, 22 pages.

CEYY.GuideInfo, Outlet Boxes and Fittings Certified for Fire Resistance, UL Online Certifications Directory, last updated May 16, 2013, 2 pages.

Civil Action No. 2:18-cv-07090. Complaint for Infringement and Unfair Competition. *DMF, Inc. v. AMP Plus, Inc. d/b/a ELCO Lighting*. 52 pages. Dated Aug. 15, 2018.

Cooper Lighting HALO ML56 LED System Product Sheet. Mar. 2, 2015. Accessed at http://www.cooperindustries.com/content/dam/public/lighting/products/documents/halo/spec_sheets/halo-ml56600-80cri-141689-sss.pdf. 8 pages.

Corrected Notice of Allowance dated Oct. 10, 2019 from U.S. Appl. No. 16/016,040, 2 pages.

Corrected Notice of Allowance dated Sep. 27, 2019 from U.S. Appl. No. 15/167,682, 2 pages.

Cree LED Lamp Family Sales Sheet—Better light is beautiful light, Apr. 24, 2017, 2 pages.

Cree® LMR2 LED Module. Product Family Data Sheet Cree 2011. 3 pages.

CS&E PCT Collaborative Search and Examination Pilot Upload Peer Contribution in International Patent Application No. PCT/US18/62868 dated Mar. 14, 2019, 61 pages.

CS&E PCT Collaborative Search and Examination Pilot Upload Peer Contribution in International Patent Application No. PCT/US18/67614 dated Apr. 24, 2019, 53 pages.

Delhi Rehab & Nursing Facility ELM16-70884. Vertex Innovative Solutions Feb. 25, 2016. 89 pages.

DMF, Inc., “dmfLIGHTING: LED Recessed Downlighting,” DRD2 Product Brochure, Oct. 23, 2014, 50 pages.

DMF, Inc., “dmfLIGHTING: LED Recessed Downlighting,” Product Catalog, Aug. 2012, 68 pages.

Ex-Parte Quayle Action mailed Jun. 27, 2019 from U.S. Appl. No. 29/683,730, 5 pages.

Final Office Action dated Apr. 2, 2015 from U.S. Appl. No. 13/484,901, 13 pages.

Final Office Action dated Apr. 27, 2016 from U.S. Appl. No. 14/184,601, 19 pages.

Final Office Action dated Jan. 29, 2016 from U.S. Appl. No. 14/183,424, 21 pages.

Final Office Action dated Jul. 26, 2017 from U.S. Appl. No. 14/184,601, 18 pages.

Final Office Action dated Jun. 23, 2016 from U.S. Appl. No. 13/484,901, 18 pages.

Final Office Action dated Jun. 6, 2019 from U.S. Appl. No. 15/688,266, 7 pages.

Final Office Action dated Mar. 15, 2019 from U.S. Appl. No. 15/132,875, 15 pages.

Final Office Action dated Oct. 3, 2019 from U.S. Appl. No. 29/678,482, 6 pages.

Final Office Action dated Sep. 27, 2019 from U.S. Appl. No. 16/200,393, 34 pages.

Halo, H7 LED Downlight Trims 49x Series, 6-inch LED Trims for Use with M17x LED Modules, Cooper Lighting, ADV110422, rev. Aug. 12, 2011, 15 pages.

Halo, Halo LED H4 H7 Collection, SustainableDesign, Cooper Lighting, (emphasis on p. 18 “H7 Collection LED Modules—Halo LED H7 Module Features,”) Mar. 28, 2012, 52 pages.

Halo, LED Module ML706x, Cooper Lighting, General Installation for All Modules/p. 1; Tether Installation/pp. 2-3; Installation into Halo H750x Series LED—only (Non-Screw Based), Recessed Fixture, p. 4, Oct. 20, 2009, 4 pages.

IC1JB Housing 4" IC-Rated New Construction Junction Box Housing. AcuityBrands. Accessed at <https://www.acuitybrands.com/en/products/detail/845886/juno/ic1jb-housing/4-ic-rated-new-construction-junction-box-housing> on Jun. 27, 2019.

Imtra Marine Lighting 2008 Catalog. 40 pages.

Imtra Marine Lighting 2009 Catalog. 32 pages.

Imtra Marine Lighting Spring 2007 Catalog. 36 pages.

International Search Report and Written Opinion in International Patent Application No. PCT/US18/39048 dated Dec. 14, 2018. 24 pages.

International Search Report and Written Opinion in International Patent Application No. PCT/US18/62868 dated Mar. 14, 2019, 13 pages.

International Search Report and Written Opinion in International Patent Application No. PCT/US18/67614 dated Apr. 25, 2019, 20 pages.

(56)

References Cited

OTHER PUBLICATIONS

International Search Report and Written Opinion in International Patent Application No. PCT/US19/32281 dated Aug. 2, 2019, 18 pages.

International Search Report and Written Opinion in International Patent Application No. PCT/US2019/036477 dated Oct. 17, 2019, 15 pages.

International Search Report and Written Opinion in PCT/US2018/048357 dated Nov. 14, 2018, 13 pages.

Kwikbrace® New Construction Braces for Lighting Fixtures or Ceiling Fans 1½ in. Depth. Hubbel. Accessed at <https://hubbelcdn.com/specsheet/926.pdf> on Jun. 27, 2019. 1 page.

ML56 LED Lighting System 600 / 900 / 1200 Series Halo. Cooper Lighting Brochure 2015. Accessed at <https://images.homedepot-static.com/catalog/pdfImages/06/06d28f93-4bf6-45be-a35a-a0239606f227.pdf>. 41 pages.

Non-Final Office Action dated Apr. 30, 2010 from U.S. Appl. No. 12/173,232, 13 pages.

Non-Final Office Action dated Apr. 4, 2019 from U.S. Appl. No. 29/678,482, 8 pages.

Non-Final Office Action dated Dec. 30, 2019 from U.S. Appl. No. 16/653,497, 8 pages.

Non-Final Office Action dated Dec. 5, 2018 from U.S. Appl. No. 14/942,937, 13 pages.

Non-Final Office Action dated Feb. 7, 2019 from U.S. Appl. No. 16/200,393, 32 pages.

Non-Final Office Action dated Feb. 6, 2018 from U.S. Appl. No. 15/167,682, 9 pages.

Non-Final Office Action dated Jul. 20, 2015 from U.S. Appl. No. 14/184,601, 16 pages.

Non-Final Office Action dated Jul. 24, 2018 from U.S. Appl. No. 29/638,259, 5 pages.

Non-Final Office Action dated Jun. 11, 2019 from U.S. Appl. No. 15/901,738, 6 pages.

Non-Final Office Action dated Jun. 2, 2015 from U.S. Appl. No. 14/183,424, 20 pages.

Non-Final Office Action dated Jun. 25, 2018 for U.S. Appl. No. 29/541,565, 10 pages.

Non-Final Office Action dated Mar. 15, 2010 from U.S. Appl. No. 12/100,148, 8 pages.

Non-Final Office Action dated May 16, 2018 for U.S. Appl. No. 15/132,875, 18 pages.

Non-Final Office Action dated May 17, 2017 from U.S. Appl. No. 14/183,424, 20 pages.

Non-Final Office Action dated Oct. 16, 2014 from U.S. Appl. No. 13/484,901, 11 pages.

Non-Final Office Action dated Oct. 24, 2018 for U.S. Appl. No. 15/688,266, 14 pages.

Non-Final Office Action dated Sep. 15, 2015 from U.S. Appl. No. 13/484,901, 16 pages.

Non-Final Office Action dated Sep. 6, 2017 from U.S. Appl. No. 14/726,064, 8 pages.

Notice of Allowance dated Apr. 1, 2019 from U.S. Appl. No. 15/167,682, 7 pages.

Notice of Allowance dated Apr. 17, 2019 from U.S. Appl. No. 29/678,478, 7 pages.

Notice of Allowance dated Apr. 8, 2019 from U.S. Appl. No. 29/653,142, 8 pages.

Notice of Allowance dated Aug. 23, 2017 from Canadian Application No. 2,879,629, 1 page.

Notice of Allowance date Feb. 15, 2019 from U.S. Appl. No. 15/947,065, 9 pages.

Notice of Allowance dated Feb. 8, 2019 from U.S. Appl. No. 29/541,565, 5 pages.

Notice of Allowance dated Jan. 16, 2015 from U.S. Appl. No. 29/467,026, 9 pages.

Notice of Allowance dated Jan. 2, 2019 from U.S. Appl. No. 29/541,565, 6 pages.

Notice of Allowance dated Jan. 28, 2019 from U.S. Appl. No. 29/664,471, 8 pages.

Notice of Allowance dated Jan. 30, 2015 from U.S. Appl. No. 13/791,087, 9 pages.

Notice of Allowance dated Jul. 31, 2019 from U.S. Appl. No. 15/167,682, 7 pages.

Notice of Allowance dated Jun. 12, 2019 from U.S. Appl. No. 16/016,040, 8 pages.

Notice of Allowance dated Mar. 24, 2016 from U.S. Appl. No. 14/247,149, 8 pages.

Notice of Allowance dated May 10, 2018 from U.S. Appl. No. 14/726,064, 7 pages.

Notice of Allowance dated Oct. 1, 2019 from U.S. Appl. No. 14/942,937, 7 pages.

Notice of Allowance dated Oct. 16, 2019 from U.S. Appl. No. 15/132,875, 12 pages.

Notice of Allowance dated Oct. 21, 2016 from U.S. Appl. No. 13/484,901, 7 pages.

Notice of Allowance dated Oct. 9, 2018 from U.S. Appl. No. 29/653,142, 7 pages.

Notice of Allowance dated Sep. 11, 2019 from U.S. Appl. No. 29/653,142, 6 pages.

Notice of Allowance dated Sep. 19, 2019 from U.S. Appl. No. 16/016,040, 7 pages.

Notice of Allowance dated Sep. 21, 2018 from U.S. Appl. No. 29/645,941, 5 pages.

OneFrame Recessed LED Downlight. Dmflighting.com. Published Jun. 6, 2018. Retrieved at <https://www.dmflighting.com/product/oneframe> on Jun. 6, 2018. 11 pages.

RACO 4 in. Octagon Welded Concrete Ring, 3½ in. Deep with ½ and ¾ in. Knockouts and includes 890 cover (20-Pack). Model # 280. Accessed at <https://www.homedepot.com/p/RACO-4-in-Octagon-Welded-Concrete-Ring-3-1-2-in-Deep-with-1-2-and-3-4-in-Knockouts-and-includes-890-cover-20-Pack-280/203638679> on Jan. 18, 2019. 3 pages.

RACO 4 in. Octagon Welded Concrete Ring, 6 in. Deep with ½ and ¾ in. Knockouts (10-Pack). Model # 276. Accessed at <https://www.homedepot.com/p/RACO-4-in-Octagon-Welded-Concrete-Ring-6-in-Deep-with-1-2-and-3-4-in-Knockouts-10-Pack-276/203638675> on Jan. 16, 2019. 4 pages.

RACO Commercial, Industrial and Residential Electrical Products. Hubbell. Accessed at www.Hubbell-RTB.com on May 6, 2019. 356 pages.

SlimSurface surface mount downlighting. Philips Lightolier 2018. 8 pages.

Specification & Features 4" Octagonal Concrete Box Covers. Orbit Industries, Inc. Accessed at <https://www.orbitelectric.com> on May 6, 2019. 1 page.

Supplemental Notice of Allowance dated Aug. 5, 2019 from U.S. Appl. No. 15/947,065, 2 pages.

Switch and Outlet Boxes and Covers Brochure. Appelton 2010. 77 pages.

U.S. Appl. No. 14/713,340, filed Oct. 23, 1923, Knight.

Notice of Allowance dated Feb. 5, 2020 from U.S. Appl. No. 15/901,738, 8 pages.

Notice of Allowance dated Feb. 5, 2020 from U.S. Appl. No. 29/678,482, 13 pages.

Maxim Lighting Wafer Trifold Brochure LMXBR01711 2017. Accessed at <https://www.maximlighting.com/Upload/download/brochure/pdf/LMXBR01711.pdf> on Feb. 13, 2020. 2 pages.

Maxim Convert Fixture. LMXCAT1805 Maxim Main Catalog 2018 p. 639.

Maxim Wafer. LMXCAT1805 Maxim Main Catalog 2018 pp. 636-638.

Maxim Lighting Trim Trifold LMXBRC1905 2019. Accessed at <https://www.maximlighting.com/Upload/download/brochure/pdf/LMXBRC1905.pdf> on Feb. 13, 2020. 2 pages.

International Search Report and Written Opinion in International Patent Application No. PCT/US2019/054220 dated Feb. 24, 2020, 23 pages.

Final Office Action dated Mar. 17, 2020 for U.S. Appl. No. 29/653,142, 13 pages.

LED Book Price Guide 2012. DMF Light. Issued Jun. 26, 2013. 3 pages.

(56)

References Cited

OTHER PUBLICATIONS

- DLER411 4"Recessed LED Retrofit Module. DMF Light. Issued Jun. 15, 2011. 1 page.
- DLEI411 4"Recessed LED New Construction, IC. DMF Light. Issued Nov. 30, 2011. 1 page.
- DLEIR411 4"Recessed LED Remodel, IC. DMF Light. Issued Jun. 15, 2011. 1 page.
- 3 & 4"DLE Series LED Sample Case Now Available. DMF Light. Issued Jan. 6, 2012. 1 page.
- DLEI3 3"Recessed LED New Construction, IC. DMF Light. Issued Nov. 30, 2011. 2 pages.
- Ridgway-Barnes, SlimSurface LED Downlight: One of the thinnest LED surface mount downlights in the market. Philips Lighting Blog. Oct. 28, 2014. Accessed at <http://applications.nam.lighting.philips.com/blog/index.php/2014/10/28/slimsurface-led-downlight-one-of-the-thinnest-led-surface-mount-downlights-in-the-market/>. 3 pages.
- SlimSurface LED S5R, S7R & S10R Round 5", 7"and 10"Apertures. Lightolier by Signify. Nov. 2018. 9 pages.
- Non-Final Office Action dated Apr. 2, 2020 for U.S. Appl. No. 16/522,275, 21 pages.
- Notice of Allowance dated May 18, 2020 from U.S. Appl. No. 15/901,738, 7 pages.
- Non-Final Office Action dated May 20, 2020 for U.S. Appl. No. 15/688,266, 6 pages.
- Non-Final Office Action dated May 26, 2020 for U.S. Appl. No. 16/719,361, 10 pages.
- Maxim Lighting International, "Wafer LED 7"RD 3000K Wall/Flush Mount", undated.
- Maxim Lighting International, "Convert LED Flush Mount", undated.
- Maxim Lighting International, "Views of the Wafer Flush Mount", undated.
- Maxim Lighting International, "Product/Drawing Specification Sheet", undated.
- International Search Report and Written Opinion in PCT/US2020/017331 dated Jun. 22, 2020, 16 pages.
- Taiwan Office Action and translation thereof dated Jun. 12, 2020 from Taiwan Application No. 108116564, 8 pages.
- Access Lighting Installation Instructions. No. 20870LEDD/20871LEDD/20872LEDD. Dec. 16, 2019. 2 pages.
- Model No. 20870LEDD-WH/ACR Infinite Specification Sheet. Access Lighting. Apr. 9, 2020.1 page.
- Corrected Notice of Allowability mailed Oct. 25, 2018 from U.S. Appl. No. 14/183,424, 3 pages.
- Dmf DRD2 Recessed LED Downlight General Retrofit Junction Box Dated: 12.18.15 Downloaded Jul. 28, 2018, from <https://www.alconlighting.com/specsheets/DMF/DRD2-Junction-Box-Retrofit-Spec-Sheet.pdf>, 6 pages.
- Dmf DRD2 Recessed LED Downlight General New Construction 4", 5", 6"Aperture Dated: Aug. 31, 2016 Downloaded Jul. 28, 2018, from https://www.cansandfans.com/sites/default/files/DRD2-General-New-Construction-Spec-Sheet_7_0.pdf, 9 pages.
- Mar. 5, 2016—The DMF Lighting DRD2 Recessed LED Downlight General Retrofit Junction Box—Wet Location Rated is the ideal solution for Commercial LED recessed lighting retrofit applications. web cache <https://www.alconlighting.com/dmf-drd2m.html> (downloaded Jul. 28, 2018), 6 pages.
- Ex Parte Quayle Office Action dated Oct. 16, 2018 for U.S. Appl. No. 29/663,037, 7 pages.
- Notice of Allowance dated Nov. 19, 2018 from U.S. Appl. No. 29/663,037, 5 pages.
- Notice of Allowance dated Nov. 15, 2018 from U.S. Appl. No. 29/663,040, 5 pages.
- LED modules advance in performance, standardization questions persist (MAGAZINE). LEDs Magazine. Oct. 29, 2013. Accessed at <https://www.ledsmagazine.com/leds-ssl-design/modular-light-engines/article/16695073/led-modules-advance-in-performance-standardization-questions-persist-magazine>. 9 pages.
- Notice of Allowance dated Jul. 20, 2020 from U.S. Appl. No. 29/648,046, 5 pages.
- Octagon Concrete Box Cover with (3) 1/2 in. & (2) 3/4 in. Conduit Knockouts. Garvin. Accessed at https://www.garvinindustries.com/covers-and-device-rings/concrete-slab-box-covers-adaptor-rings/flat-covers-all-styles/cbp?gclid=CjOKCQjw9b4BRCMARIsADMUIy pJcOK80UHdDTI9C5m4BDzR3U87PRYV1NdQIBFxEWQ2l_3otTCTqEkaAi_DEALw_wcB on Jul. 20, 2020.1 page.
- Notice of Allowance dated Jul. 28, 2020 from U.S. Appl. No. 16/719,361, 8 pages.
- Notice of Allowance dated Jul. 29, 2020 from U.S. Appl. No. 16/522,275, 8 pages.
- Non-Final Office Action dated Aug. 19, 2020 for U.S. Appl. No. 16/886,365, 16 pages.
- Petition for Inter Partes Review of U.S. Pat. No. 9,964,266 Pursuant to 37 C.F.R. § 42.100 et seq. *AMP Plus Inc. dbd ELCO Lightingv. DMF, Inc.*, IPR2019-01094 filed May 17, 2019. 108 pages.
- IPR2019-01094 Exhibit 1001. U.S. Pat. No. 9,964,266 ("the '266 Patent"). 14 pages.
- IPR2019-01094 Exhibit 1002. Declaration of Eric Bretschneider, Ph.D. ("Bretschneider"). 107 pages.
- IPR2019-01094 Exhibit 1003. Curriculum Vitae of Dr. Bretschneider. 11 pages.
- IPR2019-01094 Exhibit 1004. Excerpts from the File History of U.S. Pat. No. 9,964,266.105 pages.
- IPR2019-01094 Exhibit 1005. Imtra 2011 Marine Lighting Catalog - Advanced LED Solutions ("Imtra 2011"). 40 pages.
- IPR2019-01094 Exhibit 1006. Imtra 2007 Marine Lighting Catalog ("Imtra 2007"). 36 pages.
- IPR2019-01094 Exhibit 1007. U.S. Pat. No. 9,366,418 ("Gifford"). 9 pages.
- IPR2019-01094 Exhibit 1008. Declaration of Colby Chevalier ("Chevalier"). 89 pages.
- IPR2019-01094 Exhibit 1009. U.S. Pat. No. 7,102,172 ("Lynch"). 41 pages.
- IPR2019-01094 Exhibit 1010. Illuminating Engineering Society, Ansi RP-16-10, Nomenclature and Definitions for Illuminating Engineering (approved as an American National Standard Jul. 15, 2005, approved by the IES Board of Directors Oct. 15, 2005). 4 pages.
- IPR2019-01094 Exhibit 1011. Underwriters Laboratories Inc. Standard for Safety, Standard UL- 8750, entitled Light Emitting Diode (LED) Equipment for Use in Lighting (1st ed. 2009). 5 pages.
- IPR2019-01094 Exhibit 1012. Celanese CoolPoly® D5502 Thermally Conductive Liquid Crystalline Polymer Specification ("CoolPoly"). 1 page.
- IPR2019-01094 Exhibit 1013. Illuminating Engineering Society of North America, IES Lighting Handbook (John E. Kaufman and Howard Haynes eds., Application vol. 1981) ("Lighting Handbook"). 5 pages.
- IPR2019-01094 Exhibit 1014. California Energy Commission, PIER Lighting Research Program: Project 2.3 Low-profile LED Luminaires Final Report (Prepared by Lighting Research Center, Jan. 2005) ("PER LRP"). 70 pages.
- IPR2019-01094 Exhibit 1015. Jim Sinopoli, Using DC Power to Save Energy and End the War on Currents, GreenBiz (Nov. 15, 2012), <https://www.greenbiz.com/news/2012/11/15/using-dc-power-save-energy-end-war-currents> ("Sinopoli"). 6 pages.
- IPR2019-01094 Exhibit 1016. Robert W. Johnson, "Thought Leadership White Paper: AC Versus DC Power Distribution" (Nov. 2012) ("Johnson"). 10 pages.
- IPR2019-01094 Exhibit 1017. Lumileds, LUXEON Rebel General Purpose Product Datasheet, Specification DS64 (2016) ("Luxeon Rebel"). 26 pages.
- IPR2019-01094 Exhibit 1018. U.S. Pat. No. 8,454,204 ("Chang"). 11 pages.
- IPR2019-01094 Exhibit 1019. U.S. Department of Energy, CALiPER Benchmark Report: Performance of Incandescent A-Type and Decorative Lamps and LED Replacements (prepared by Pacific National Laboratory, Nov. 2008) ("CALiPER 2008"). 25 pages.
- IPR2019-01094 Exhibit 1020. U.S. Pat. No. 3,836,766 ("Auerbach"). 13 pages.

(56)

References Cited

OTHER PUBLICATIONS

IPR2019-01094 Exhibit 1021. U.S. Department of Energy, CALiPER Application Summary Report 16: Led BR30 and R30 Lamps (prepared by Pacific Northwest National Laboratory, Jul. 2012) (“CALiPER 2012”). 26 pages.

IPR2019-01094 Exhibit 1022. Sandia National Laboratories, Sandia Report: “The Case for a National Research Program on Semiconductor Lighting” (Jul. 2000) (“Haitz”). 24 pages.

IPR2019-01094 Exhibit 1023. Sylvania, Post Top Street Light LED Retrofit Kit Specification, LED40POST (2009) (“Sylvania”). 4 pages.

IPR2019-01094 Exhibit 1024. Webster’s New Collegiate Dictionary (1973) (“Webster’s”). 2 pages.

IPR2019-01094 Exhibit 1025. 3M Wire Connectors and Tools Catalog 2013 (“3M Catalog”). 22 pages.

IPR2019-01094 Exhibit 1026. Wakefield Semiconductor Heat Sinks and Thermal Products 1974 Catalog (“Wakefield”). 3 pages.

IPR2019-01094 Exhibit 1027. U.S. Department of Energy, Solid-State Lighting Research and Development Portfolio: Multi-Year Program Plan FY’07-FY’12 (prepared by Navigant Consulting, Inc., Mar. 2006) (“DOE 2006”). 129 pages.

IPR2019-01094 Exhibit 1028. U.S. Department of Energy, Solid-State Lighting Research and Development: Multi-Year Program Plan (Apr. 2013) (“DOE 2013”). 89 pages.

Declaration of Colby Chevalier from Central District of California Civil Docket for Case #: 2:18-cv-07090-CAS-GJS filed Jun. 3, 2019, signed Jun. 3, 2019. 2 pages.

Docket Listing in Inter Partes Review of U.S. Pat. No. 9,964,266. Docket Navigator *AMP Plus, Inc. d/b/a Elco Lighting et al. v. DMF, Inc.* PTAB-IPR2019-01094. Downloaded Mar. 25, 2020. 4 pages.

Petition for Inter Partes Review of U.S. Pat. No. 9,964,266 Pursuant to 37 C.F.R. § 42.100 et seq. *AMP Plus Inc. dbd ELCO Lighting v. DMF, Inc.* PTAB-IPR2019-01500 filed Aug. 14, 2019. 99 pages.

Docket Listing in Inter Partes Review of U.S. Pat. No. 9,964,266 . *AMP Plus, Inc. d/b/a ELCO Lighting et al. v. DMF, Inc.* PTAB-IPR2019-01500. Downloaded Mar. 25, 2020. 3 pages.

Docket Listing in Civil Action No. 2:18-cv-07090. *DMF, Inc. v. AMP Plus, Inc. d/b/a ELCO Lighting et al.* CDCA-2-18-CV-07090. Downloaded on Mar. 25, 2020. 39 pages.

Civil Action No. 2:19-cv-4519. Complaint For Patent Infringement. *DMF, Inc. v. AMP Plus, Inc. d/b/a ELCO Lighting.* 52 pages dated May 22, 2019. 23 pages.

Docket Listing in Civil Action No. 2:19-cv-4519. *DMF Inc. v. AMP Plus, Inc. d/b/a ELCO Lighting et al.* CDCA-2-19-cv-04519. Downloaded on Mar. 25, 2020. 3 pages.

Decision Denying Institution of Inter Partes Review of U.S. Pat. No. 9,964,266 in IPR2019-01500 dated Mar. 17, 2020. 21 pages.

Defendants’ Notice of Prior Art Pursuant To 35 U.S.C. § 282 in Civil Action No. 2:18-cv-07090-CAS-GJS dated Feb. 28, 2020. 7 pages.

Defendant AMP Plus, Inc.’s Opposition to DMF’s Motion for Summary Judgement in Civil Action No. 2:18-cv-07090-CAS-GJS filed Feb. 10, 2020. 32 pages.

Declaration of Eric Bretschneider, Ph.D In Support of Amp Plus, Inc.’s Opposition to Dmf, Inc.’s Motion for Partial Summary Judgment in Civil Action No. 2:18-cv-07090-CAS-GJS filed Feb. 10, 2020. 210 pages.

Plaintiff DMF’s Reply in Support Of Motion For Partial Summary Judgment in Civil Action No. 2:18-cv-07090-CAS-GJS filed Feb. 18, 2020. 33 pages.

Declaration of James R. Benya In Support of Plaintiff DMF’s Motion for Summary Judgment in Civil Action No. 2:18-cv-07090-CAS-GJS filed Feb. 3, 2020. 193 pages.

Underwriters Laboratories Inc. Standard for Safely. UL 1598. Luminaires Jan. 11, 2020. 12 pages.

Exceptional LED Lighting Technology Product Portfolio. LightingScience 2012. 11 pages.

“Cree LMH2 Led Modules,” Mouser Electronics. Sep. 9, 2012. 4 pages.

Slim Line Disc. EYE LEDs Specification Sheet 2012. 2 pages.

HiBay LED Heat Sink. Wakefield-vette. Dec. 11, 2017. 1 pages.

Thermal Management of Cree® XLamp® LEDs. Cree Application Note. 2004. 19 pages.

Imtra Marine Lighting Fall 2007 Catalog. 32 pages.

Notice of Allowance dated Apr. 9, 2020 from U.S. Appl. No. 16/653,497, 7 pages.

Notice of Allowance dated Sep. 8, 2020 from U.S. Appl. No. 29/678,482, 5 pages.

Corrected Notice of Allowance dated Sep. 11, 2020 from U.S. Appl. No. 16/719,361, 2 pages.

Canadian Office Action in Application No. 2931588 dated Aug. 13, 2020, 5 pages.

Corrected Notice of Allowance dated Sep. 14, 2020 from U.S. Appl. No. 16/522,275, 2 pages.

Notice of Allowance dated Sep. 22, 2020 from U.S. Appl. No. 29/683,730, 6 pages.

Notice of Allowance dated Sep. 22, 2020 from U.S. Appl. No. 29/653,142, 6 pages.

Notice of Allowance dated Oct. 27, 2020 from U.S. Appl. No. 29/648,046, 5 pages.

Notice of Allowance dated Nov. 10, 2020 from U.S. Appl. No. 29/688,143, 6 pages.

Notice of Allowance dated Nov. 10, 2020 from U.S. Appl. No. 29/688,172, 6 pages.

Non-Final Office Action dated Nov. 30, 2020 from U.S. Appl. No. 17/000,702, 7 pages.

Notice of Allowance dated Dec. 2, 2020 from U.S. Appl. No. 29/746,262, 6 pages.

International Search Report and Written Opinion in PCT/US2020/050767 dated Dec. 9, 2020, 25 pages.

Non-Final Office Action dated Dec. 16, 2020 from U.S. Appl. No. 17/080,080, 28 pages.

Canadian Office Action in Application No. 2941051 dated Dec. 8, 2020, 5 pages.

Final Office Action dated Jan. 11, 2021 from U.S. Appl. No. 15/688,266, 7 pages.

Non-Final Office Action dated Jan. 11, 2021 from U.S. Appl. No. 16/725,606, 7 pages.

Non-Final Office Action dated Jan. 13, 2021 from U.S. Appl. No. 17/085,636, 14 pages.

Notice of Allowance dated Jan. 15, 2021 from U.S. Appl. No. 17/000,702, 7 pages.

Notice of Allowance dated Jan. 22, 2021 from U.S. Appl. No. 17/080,080, 14 pages.

Notice of Allowance dated Jan. 22, 2021 from U.S. Appl. No. 16/886,365, 7 pages.

Final Office Action dated Feb. 5, 2021 from U.S. Appl. No. 16/200,393, 7 pages.

“Electrical Boxes” accessed at <http://electrical-inspector.blogspot.com/2013/06/electrical-boxes.html> Jun. 22, 2013 retrieved from Wayback Machine Archinve.org on Jan. 25, 2021. 12 pages.

“Electrical Boxes Volume and Fill Calculations” accessed at <http://electrical-inspector.blogspot.com/2013/06/electrical-boxes-Volume-and-Fill-Calculations.html> Jun. 22, 2013 retrieved from Wayback Machine Archinve.org on Jan. 25, 2021. 8 pages.

U.S. Appl. No. 61/881,162, filed Sep. 23, 2013. Priority application to US Publication No. 2015/0085500 to Cooper et al. 31 pages.

Non-Final Office Action dated Jan. 19, 2021 from U.S. Appl. No. 17/099,650, 15 pages.

Supplemental Notice of Allowance dated Mar. 10, 2021 from U.S. Appl. No. 16/886,365, 2 pages.

Notice of Allowance dated Apr. 6, 2021 from U.S. Appl. No. 16/200,393, 11 pages.

Notice of Allowance dated Apr. 13, 2021 from U.S. Appl. No. 16/725,606, 7 pages.

Notice of Allowance dated Apr. 26, 2021 from U.S. Appl. No. 17/080,080, 11 pages.

Corrected Notice of Allowance dated Apr. 28, 2021 from U.S. Appl. No. 16/725,606, 2 pages.

Notice of Allowance dated May 5, 2021 from U.S. Appl. No. 17/085,636, 8 pages.

Notice of Allowance dated May 14, 2021 from U.S. Appl. No. 16/881,686, 8 pages.

(56)

References Cited

OTHER PUBLICATIONS

Notice of Allowance dated May 17, 2021 from U.S. Appl. No. 15/688,266, 9 pages.

Notice of Allowance dated May 24, 2021 from U.S. Appl. No. 29/688,143, 6 pages.

Notice of Allowance dated May 24, 2021 from U.S. Appl. No. 29/688,172, 6 pages.

Notice of Allowance dated May 27, 2021 from U.S. Appl. No. 16/779,865, 9 pages.

Notice of Allowance dated May 28, 2021 from U.S. Appl. No. 16/779,824, 11 pages.

Notice of Allowance dated Jun. 1, 2021 from U.S. Appl. No. 16/719,361, 7 pages.

Corrected Notice of Allowance dated Jun. 21, 2021 from U.S. Appl. No. 16/779,865, 3 pages.

Non-Final Office Action dated Jul. 14, 2021 from U.S. Appl. No. 17/118,742, 11 pages.

Notice of Allowance dated Jul. 21, 2021 from U.S. Appl. No. 17/318, 13 pages.

Supplemental Notice of Allowance dated Aug. 13, 2021 1 from U.S. Appl. No. 16/779,824, 3 pages.

Supplemental Notice of Allowance dated Aug. 19, 2021 1 from U.S. Appl. No. 17/318,193, 4 pages.

Notice of Allowance dated Aug. 20, 2021 1 from U.S. Appl. No. 29/764,875, 5 pages.

Notice of Allowance dated Sep. 16, 2021 from U.S. Appl. No. 16/779,865, 9 pages.

Cree LMH2 Led Modules Product Family Data Sheet. Cree 2011-2014, 18 pages.

Cree LMH2 Led Modules Design Guide. Cree 2011-2015, 23 pages.

Brochure of Elco EL49A, EL49ICA, EL49RA modules. ELCO Lighting Nov. 25, 2009.1 page.

Image of Elco E347/247 module identified by Elco in response to DMF's Request for Production in Civil Action No. 2:18-cv-07090-CAS-GJS on Aug. 28, 2019.1 page.

Screenshots from the Deposition of Brandon Cohen in Civil Action No. 2:18-cv-07090-CAS-GJS. Conducted Sep. 2, 2020. 8 pages.

Defendant AMP Plus, Inc.'s Initial Disclosure and Designation of Expert Witnesses in Civil Action No. 2:19-CV-4519-CAS. 37 pages.

Defendant AMP Plus, Inc. D/B/A Elco Lighting's Supplemental Responses to Plaintiff DMF, Inc.'s First Set of Interrogatories (Nos. 1-16) in Civil Action No. 2:19-CV-4519-CAS, Redacted. 13 pages.

Final Written Decision in IPR2019-01094 dated Nov. 19, 2020, 58 pages.

U.S. Appl. No. 16/883,144, filed May 26, 2020, Nikooyan et al..

U.S. Appl. No. 29/696,830, filed Jul. 1, 2019, Kopitzke.

U.S. Appl. No. 16/182,481, filed Nov. 6, 2018, Kopitzke.

U.S. Appl. No. 29/762,016, filed Dec. 14, 2020, Williams et al..

U.S. Appl. No. 17/118,742, filed Dec. 11, 2020, Danesh et al..

U.S. Appl. No. 29/752,046, filed Sep. 24, 2020, Peng et al..

U.S. Appl. No. 17/229,668, filed Apr. 13, 2021, Shen.

U.S. Appl. No. 17/318,193, filed May 12, 2021, Danesh et al..

U.S. Appl. No. 17/080,080, filed Oct. 26, 2020, Danesh.

U.S. Appl. No. 17/220,779, filed Apr. 1, 2021, Kopitzke et al..

U.S. Appl. No. 17/395,522, filed Aug. 6, 2021, Danesh.

U.S. Appl. No. 17/385,766, filed Jul. 26, 2021, Kopitzke.

U.S. Appl. No. 17/384,564, filed Jul. 23, 2021, Kopitzke et al..

U.S. Appl. No. 17/381,147, filed Jul. 20, 2021, Lotti et al..

U.S. Appl. No. 17/379,748, filed Jul. 19, 2021, Young et al..

U.S. Appl. No. 17/379,489, filed Jul. 19, 2021, Vinh et al..

U.S. Appl. No. 17/378,214, filed Jul. 16, 2021, Kopitzke et al..

U.S. Appl. No. 17/374,674, filed Jul. 13, 2021, Danesh.

U.S. Appl. No. 17/234,421, dated Apr. 19, 2021, Danesh.

U.S. Appl. No. 29/764,875, dated Jan. 4, 2021, Danesh et al.

U.S. Appl. No. 29/759,492, dated Nov. 23, 2020, Danesh et al.

U.S. Appl. No. 17/099,650, dated Nov. 16, 2020, Danesh et al.

U.S. Appl. No. 29/757,754, dated Nov. 9, 2020, Danesh et al.

U.S. Appl. No. 17/473,934, dated Sep. 13, 2021, Danesh et al.

Non-Final Office Action dated Oct. 18, 2021 from U.S. Appl. No. 29/696,830, 8 pages.

Notice of Allowance dated Nov. 3, 2021 from U.S. Appl. No. 17/220,779, 7 pages.

Notice of Allowance dated Nov. 5, 2021 1 from U.S. Appl. No. 17/318,193, 11 pages.

Non-Final Office Action dated Nov. 5, 2021 from U.S. Appl. No. 17/379,748, 8 pages.

Notice of Allowance dated Nov. 8, 2021 1 from U.S. Appl. No. 29/764,875, 5 pages.

Non-Final Office Action dated Nov. 15, 2021 from U.S. Appl. No. 17/374,674, 7 pages.

* cited by examiner

‡ imported from a related application

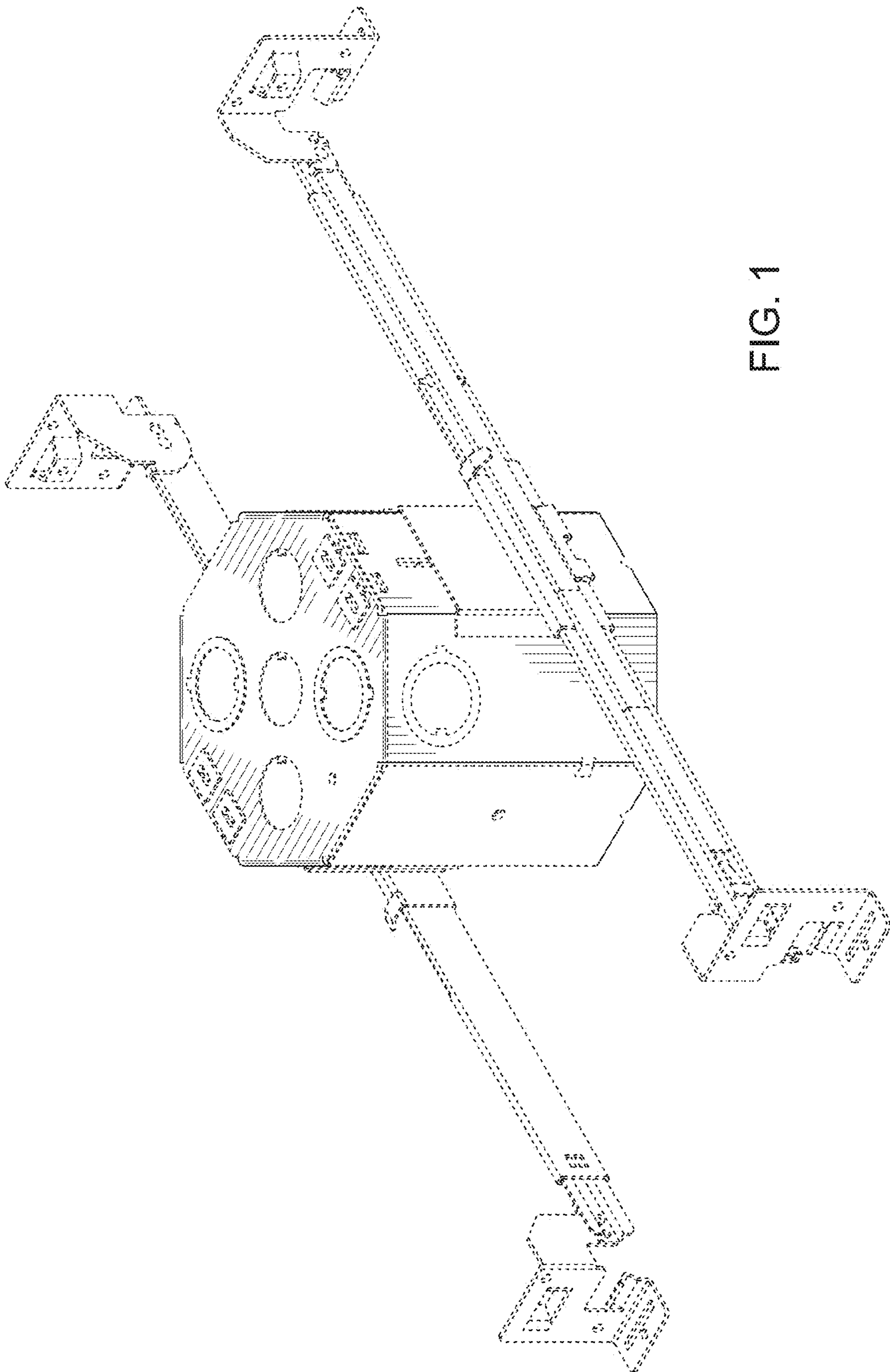

FIG. 1

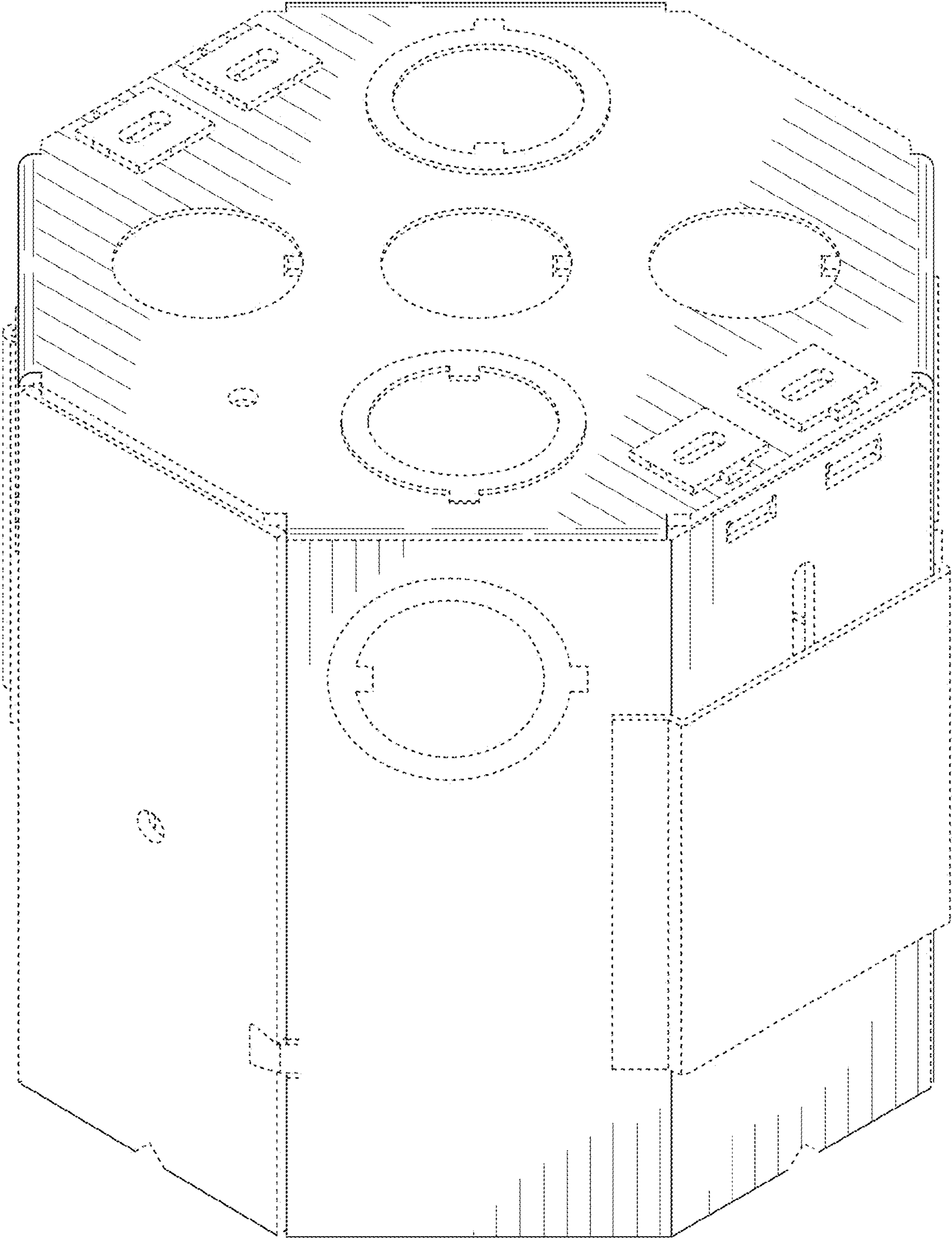

FIG. 2

FIG. 3

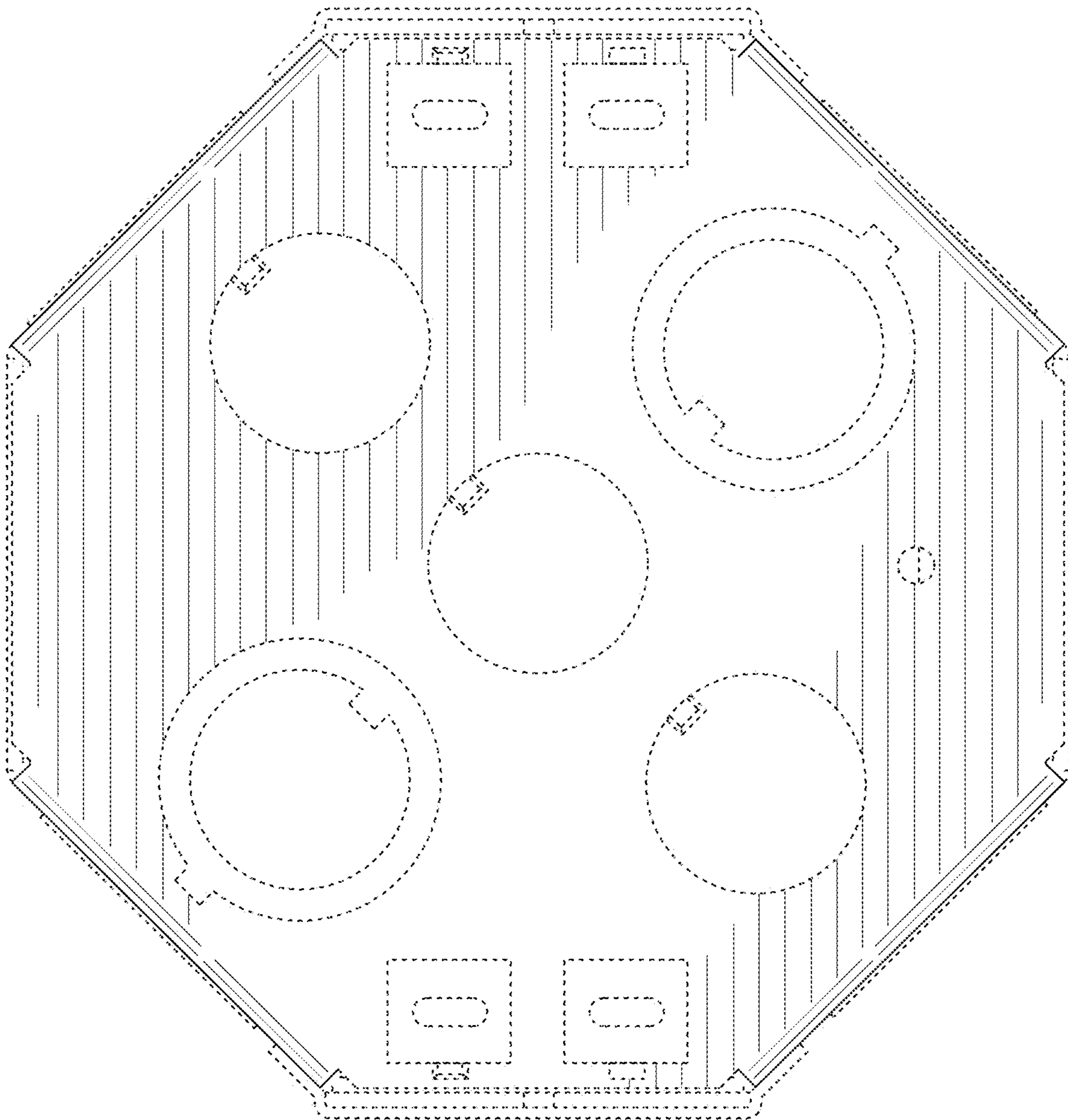

FIG. 4

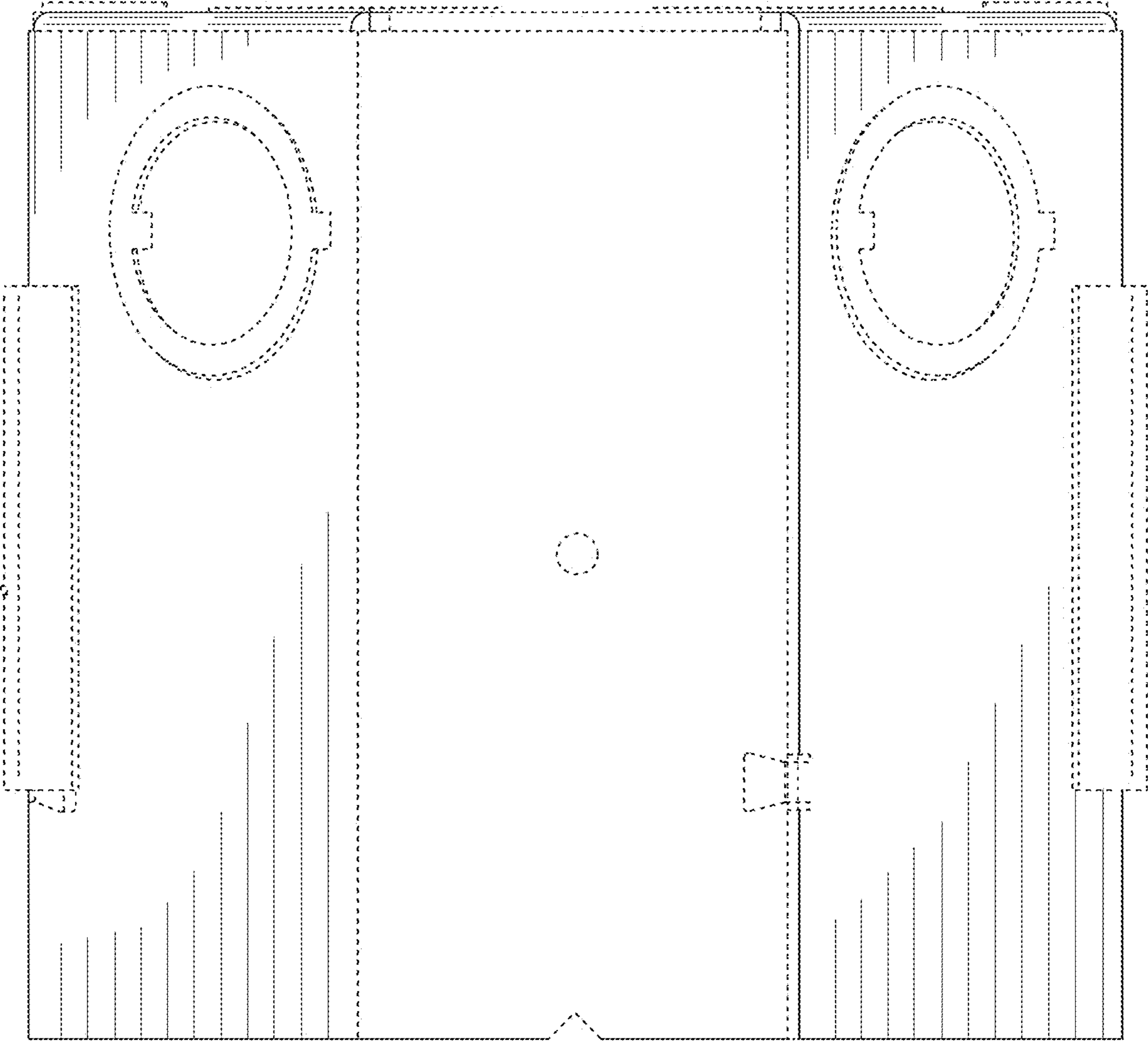

FIG. 5

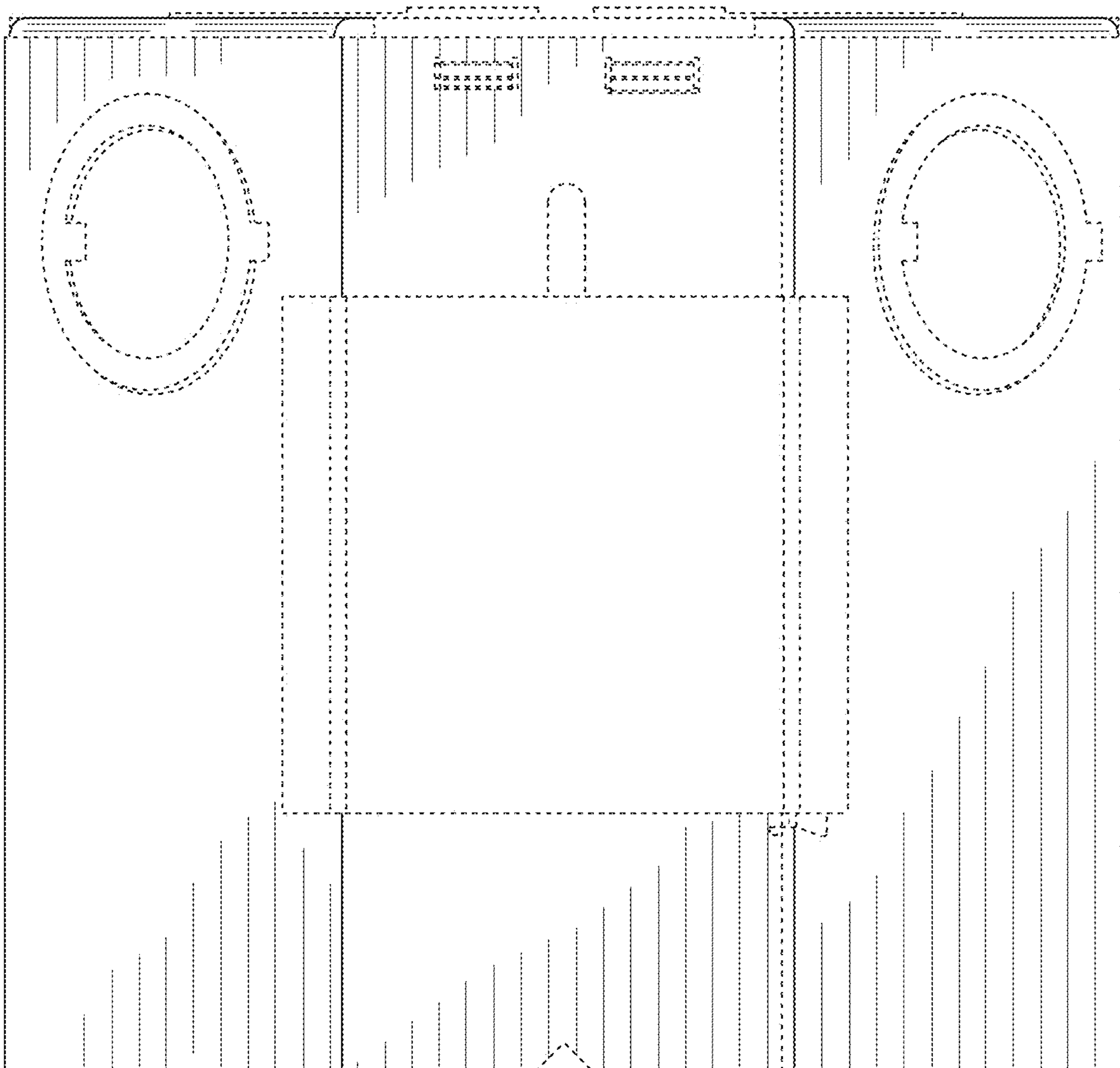

FIG. 6

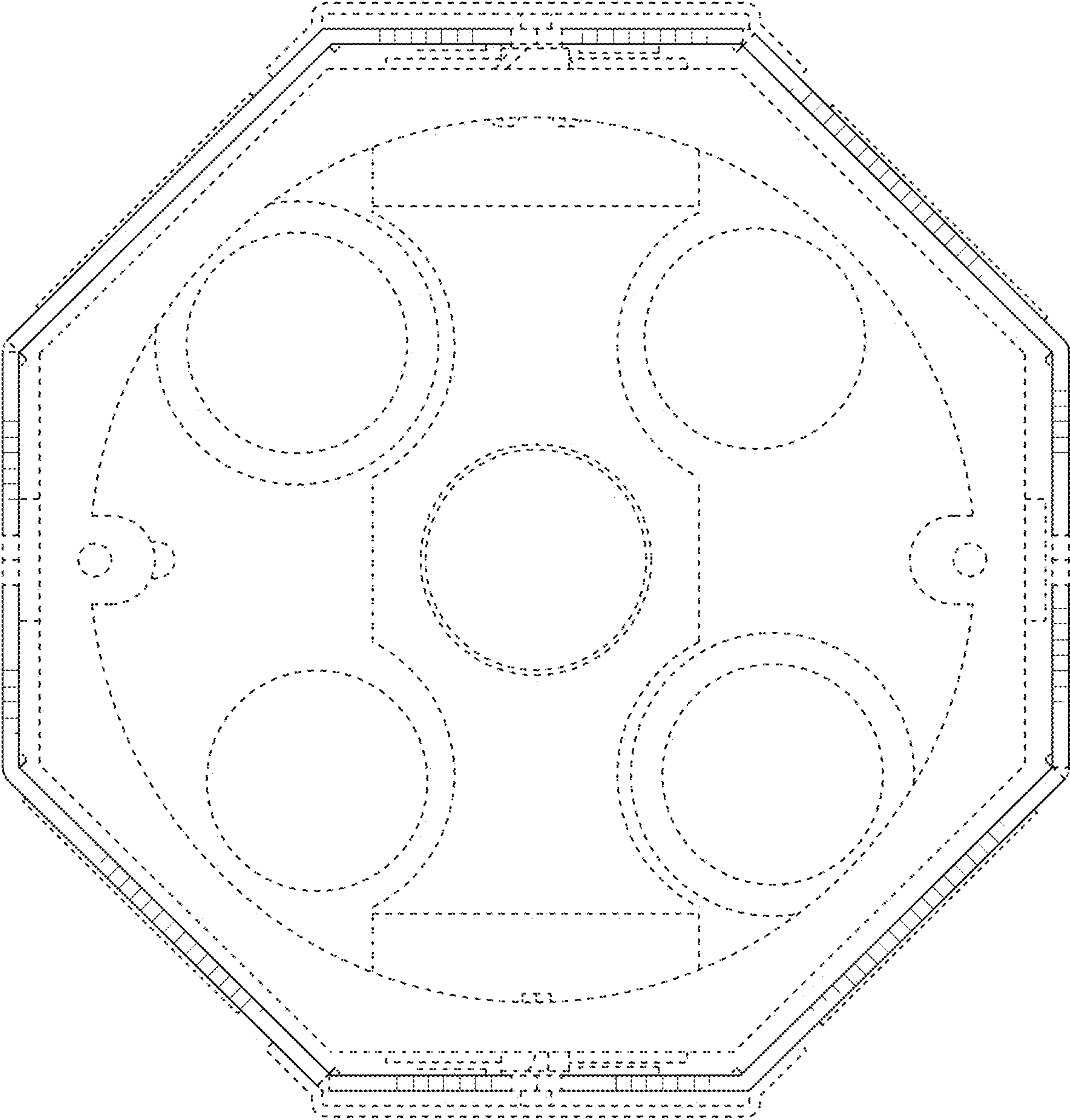
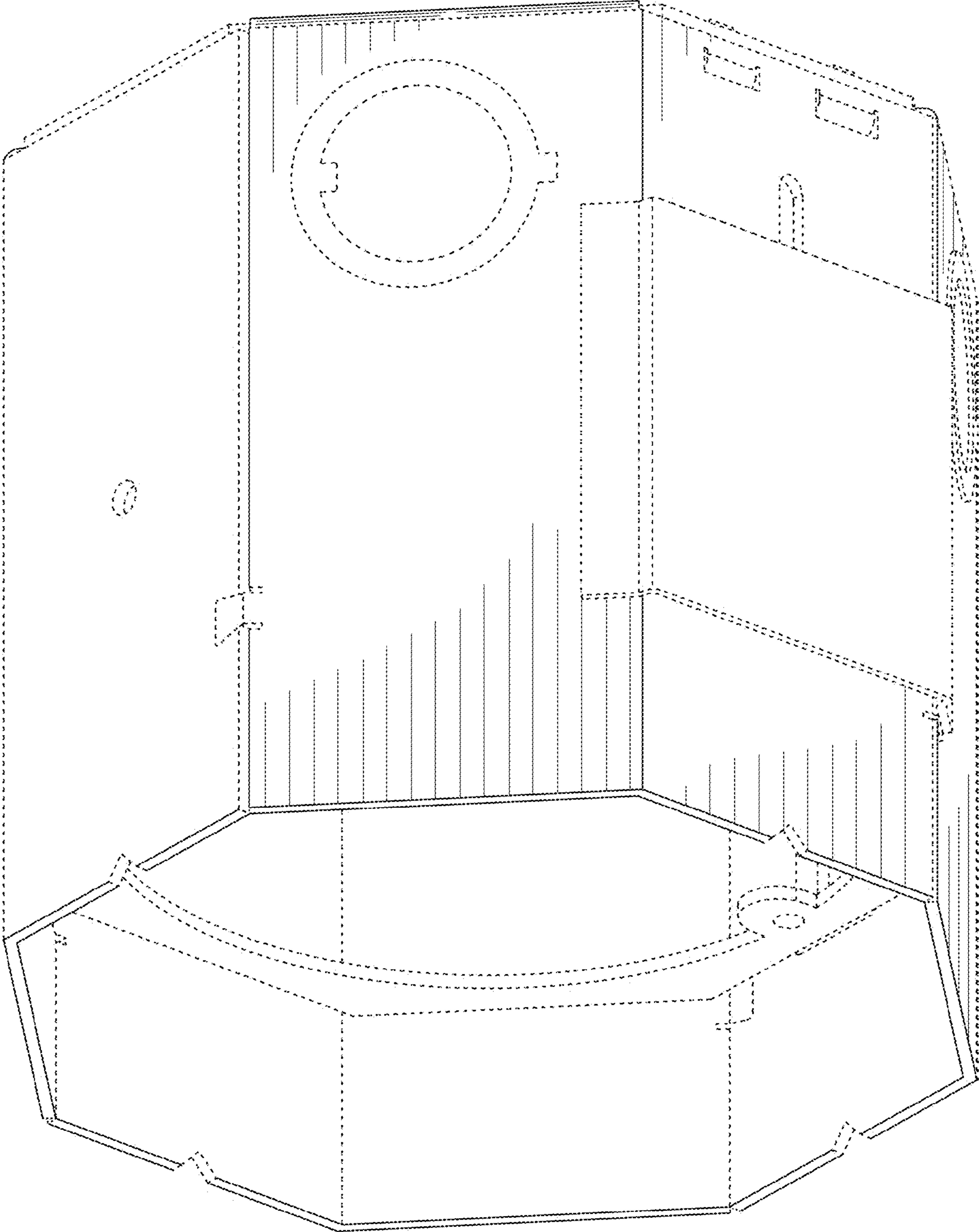

FIG. 7



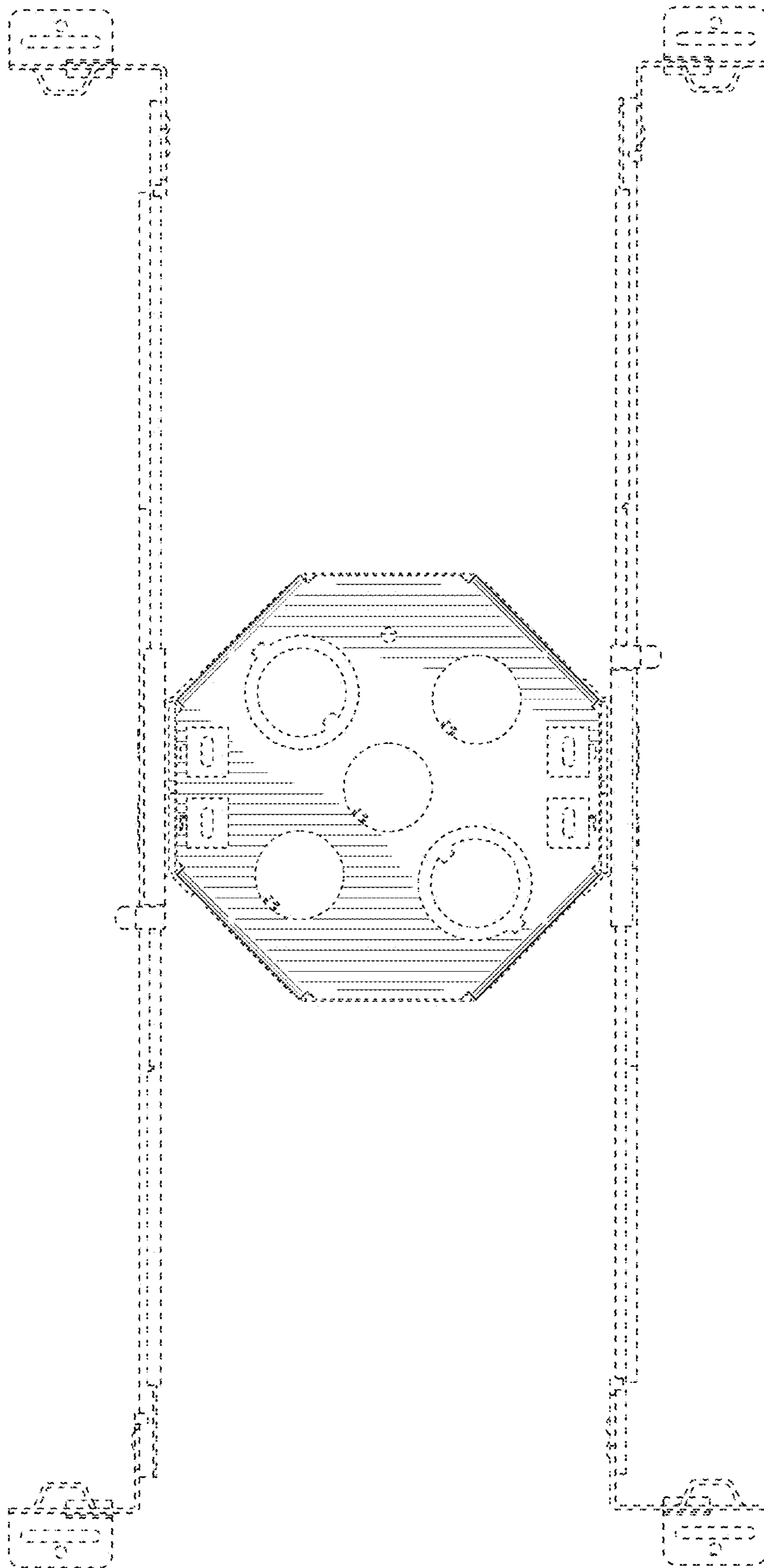
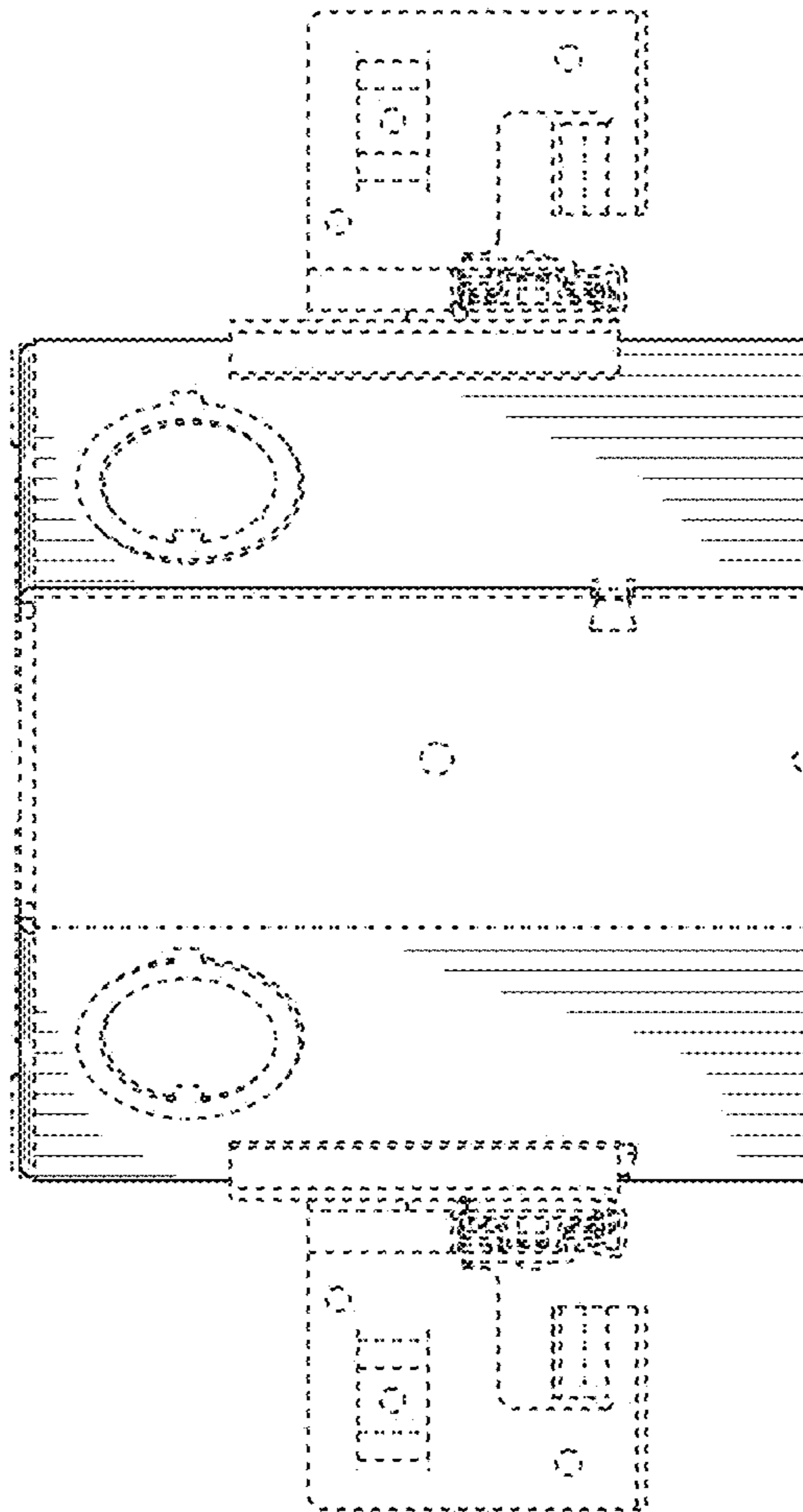

FIG. 8

FIG. 9



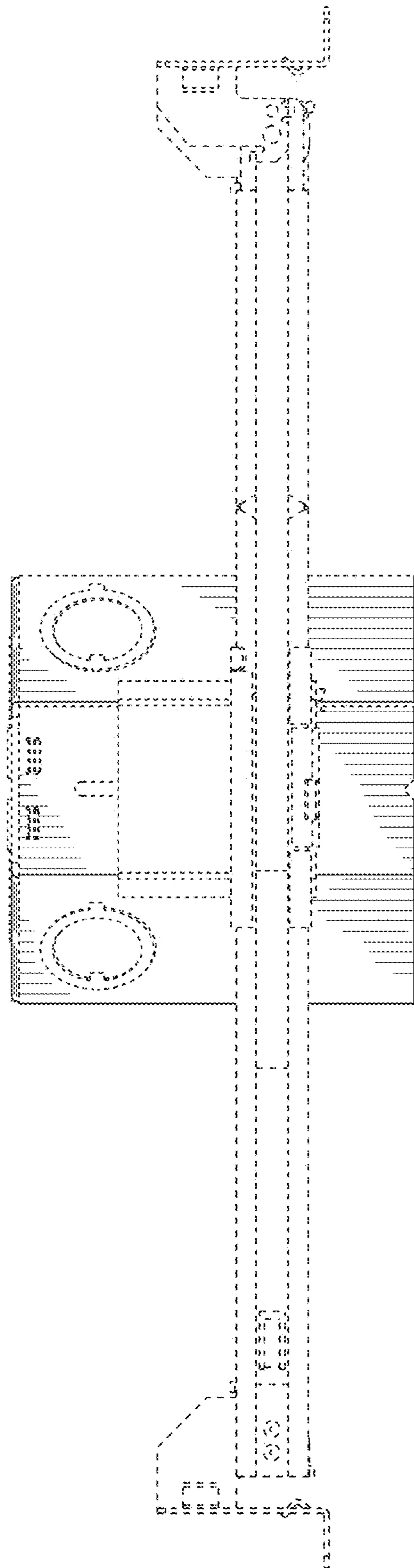

FIG. 10

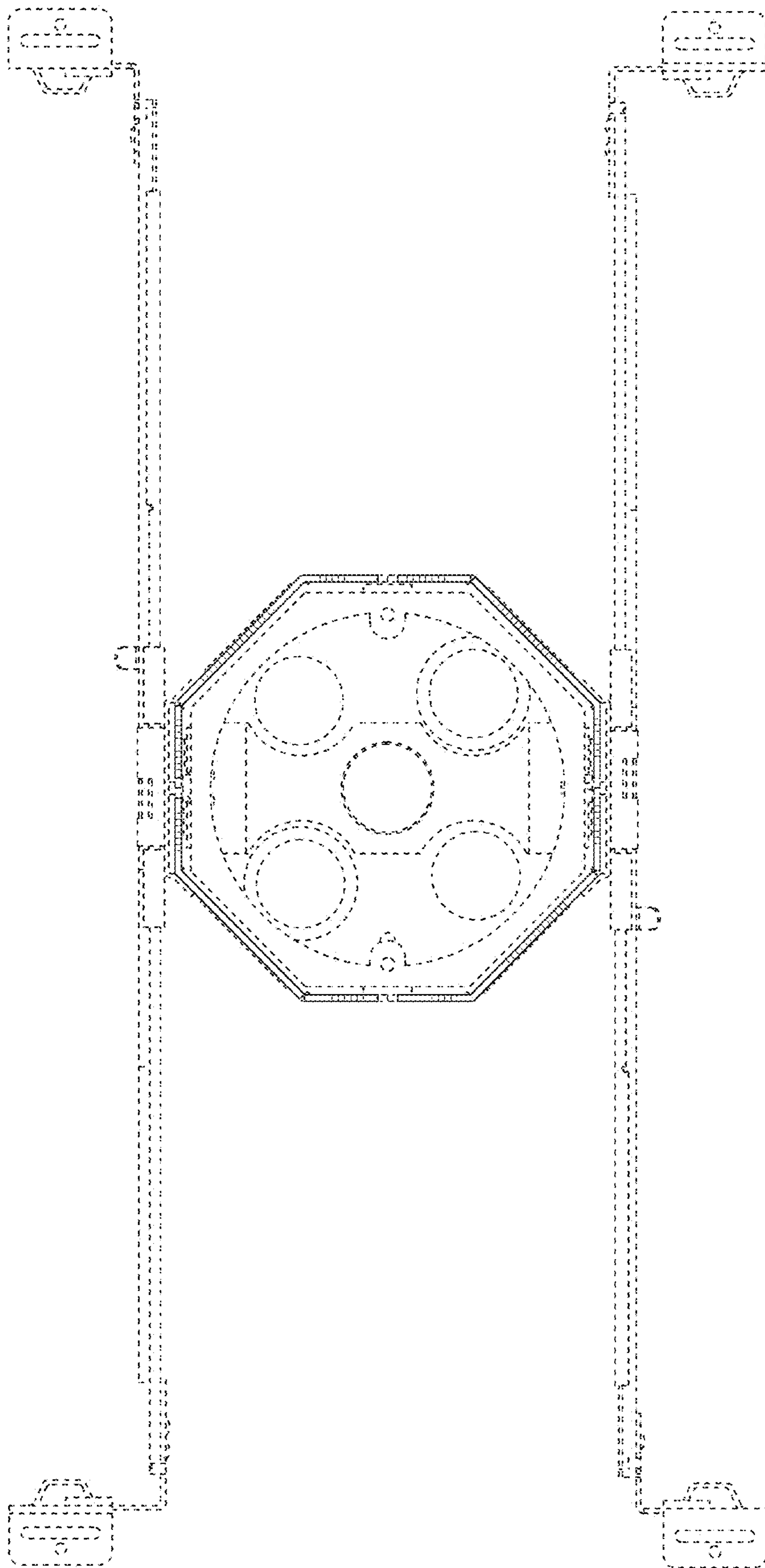

FIG. 11

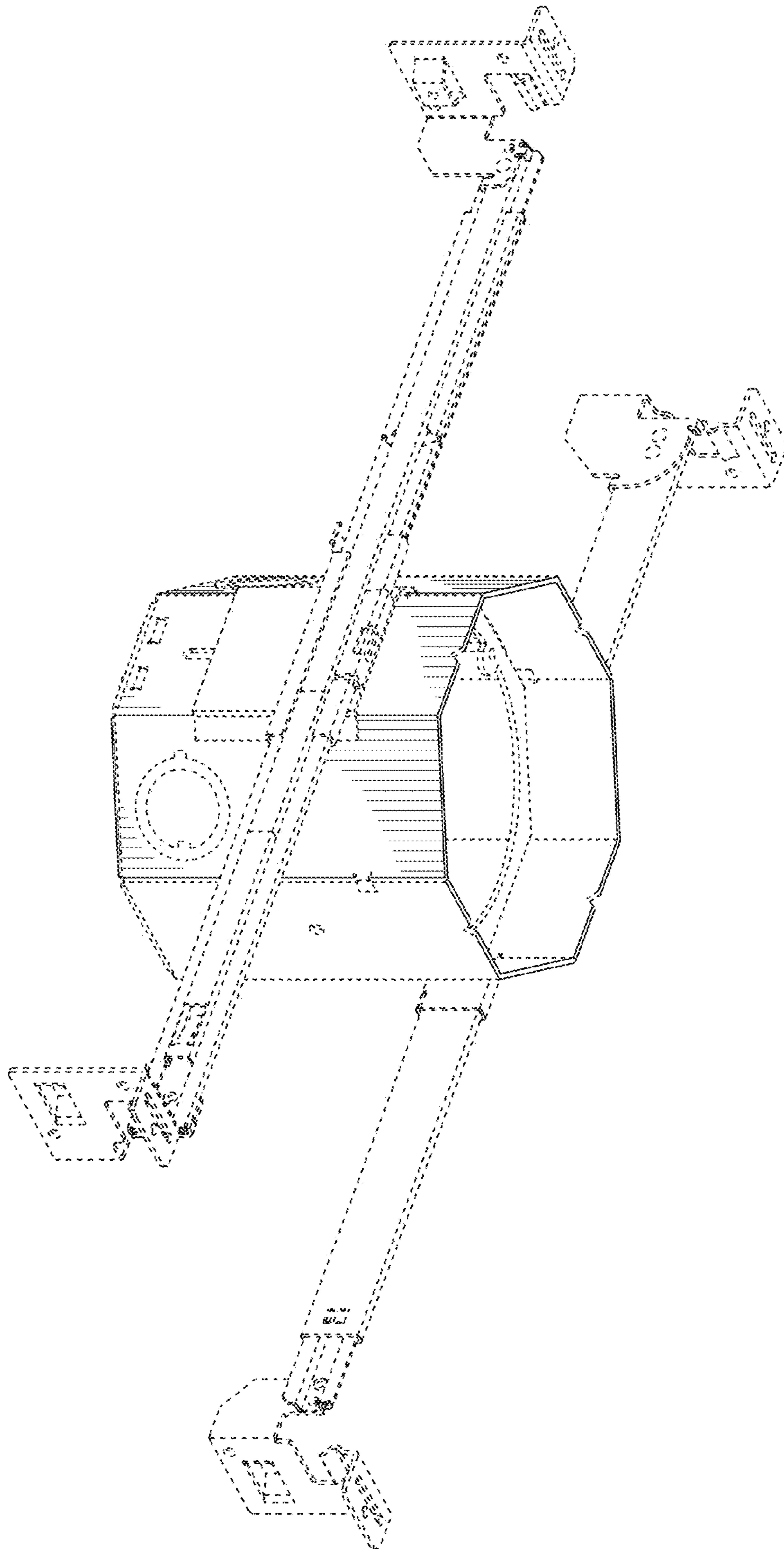

FIG. 12