



US00D944030S

(12) **United States Design Patent**  
**Wright et al.**

(10) **Patent No.:** **US D944,030 S**  
(45) **Date of Patent:** **\*\* Feb. 22, 2022**

- (54) **MATTRESS COVER**
- (71) Applicant: **FAINT ORANGE HORIZON, INC.**,  
Walpole, MA (US)
- (72) Inventors: **Austin Wright**, Los Angeles, CA (US);  
**David Shoham**, Los Angeles, CA (US)
- (73) Assignee: **Faint Orange Horizon, Inc.**, Walpole,  
MA (US)
- (\*\*) Term: **15 Years**
- (21) Appl. No.: **29/738,254**
- (22) Filed: **Jun. 16, 2020**
- (51) **LOC (13) Cl.** ..... **06-09**
- (52) **U.S. Cl.**  
USPC ..... **D6/601**
- (58) **Field of Classification Search**  
USPC ..... D6/595-601, 604, 611; D21/803, 804;  
D24/183  
CPC ..... A47C 7/12; A47C 7/021; A47C 7/383;  
A47C 7/425; A47C 7/428; A47C 7/546;  
A47C 16/00; A47C 20/00; A47C 20/02;  
A47C 20/021; A47C 20/026; A47C  
20/027; A47C 31/11; A47C 27/001; A47C  
27/081; A47C 1/146; A47G 9/00; A47G  
9/10; A47G 9/07; A47G 9/1027; A47G  
9/1045; A47G 9/1054; A47G 9/1063;  
A47G 9/1072; A47G 9/1081; A47G  
9/109; A47G 2009/1018; A47G  
2009/1036  
See application file for complete search history.

(56) **References Cited**

**U.S. PATENT DOCUMENTS**

- 2,693,847 A \* 11/1954 Kablotsky ..... A47C 27/001  
267/145
- 3,968,529 A \* 7/1976 Levin ..... A47G 9/10  
5/640

- 4,914,767 A \* 4/1990 Balicki ..... A47G 9/062  
135/118
- D328,937 S \* 8/1992 Becella ..... D21/792
- D336,986 S \* 7/1993 Seymour ..... D3/233
- D366,380 S \* 1/1996 Kelly ..... D6/596
- D388,651 S \* 1/1998 Graebe ..... D6/596
- D414,643 S \* 10/1999 Phua ..... D6/582
- D418,355 S \* 1/2000 DeCet ..... D6/595
- D479,561 S \* 9/2003 Meyer ..... D20/22
- D516,360 S \* 3/2006 Henning ..... D6/592
- D681,738 S \* 5/2013 Richmond ..... D20/42
- D738,444 S \* 9/2015 Hilson ..... D21/662
- D815,461 S \* 4/2018 Christmas ..... D6/605
- D840,481 S \* 2/2019 Pryce ..... D21/686
- D847,280 S \* 4/2019 Pryce ..... D21/686
- D855,355 S \* 8/2019 McClellan-Miller ..... D6/603
- D859,891 S \* 9/2019 Jensen ..... D6/606
- D914,396 S \* 3/2021 Albino ..... D6/585
- D915,786 S \* 4/2021 Brown ..... D6/582
- D916,528 S \* 4/2021 Alletto, Jr. .... D6/606
- D921,166 S \* 6/2021 Meyers ..... D23/261
- D926,494 S \* 8/2021 Alletto, Jr. .... D6/606

(Continued)

*Primary Examiner* — Jennifer L Rempfer

(74) *Attorney, Agent, or Firm* — Brooks Kushman P.C.

(57) **CLAIM**

The ornamental design for a mattress cover, as shown and described.

**DESCRIPTION**

FIG. 1 is a bottom perspective view of an ornamental design for a mattress cover;  
 FIG. 2 is a front elevational view thereof;  
 FIG. 3 is a back elevational view thereof; and,  
 FIG. 4 is an expanded detailed view of the encircled area 4 of FIG. 3 showing an opening for receiving a valve of an inflatable mattress which is shown in broken lines.  
 Dashed features illustrate environmental structure and form no part of the claimed design.

**1 Claim, 4 Drawing Sheets**

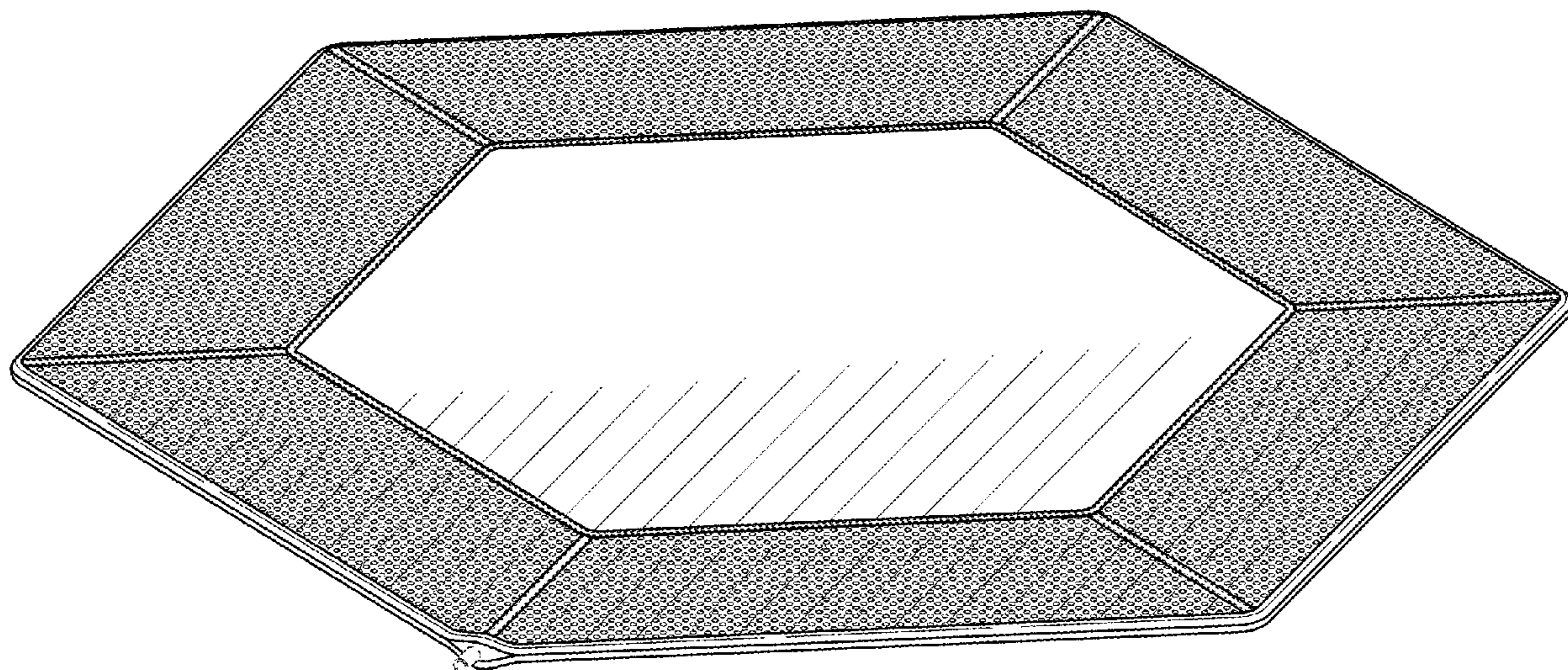

(56)

**References Cited**

U.S. PATENT DOCUMENTS

2005/0229317 A1\* 10/2005 Heiser ..... A47C 27/144  
5/653  
2009/0100601 A1\* 4/2009 Battaglia ..... A47C 20/025  
5/631  
2015/0020311 A1\* 1/2015 Bensoussan ..... A47G 9/0246  
5/497

\* cited by examiner



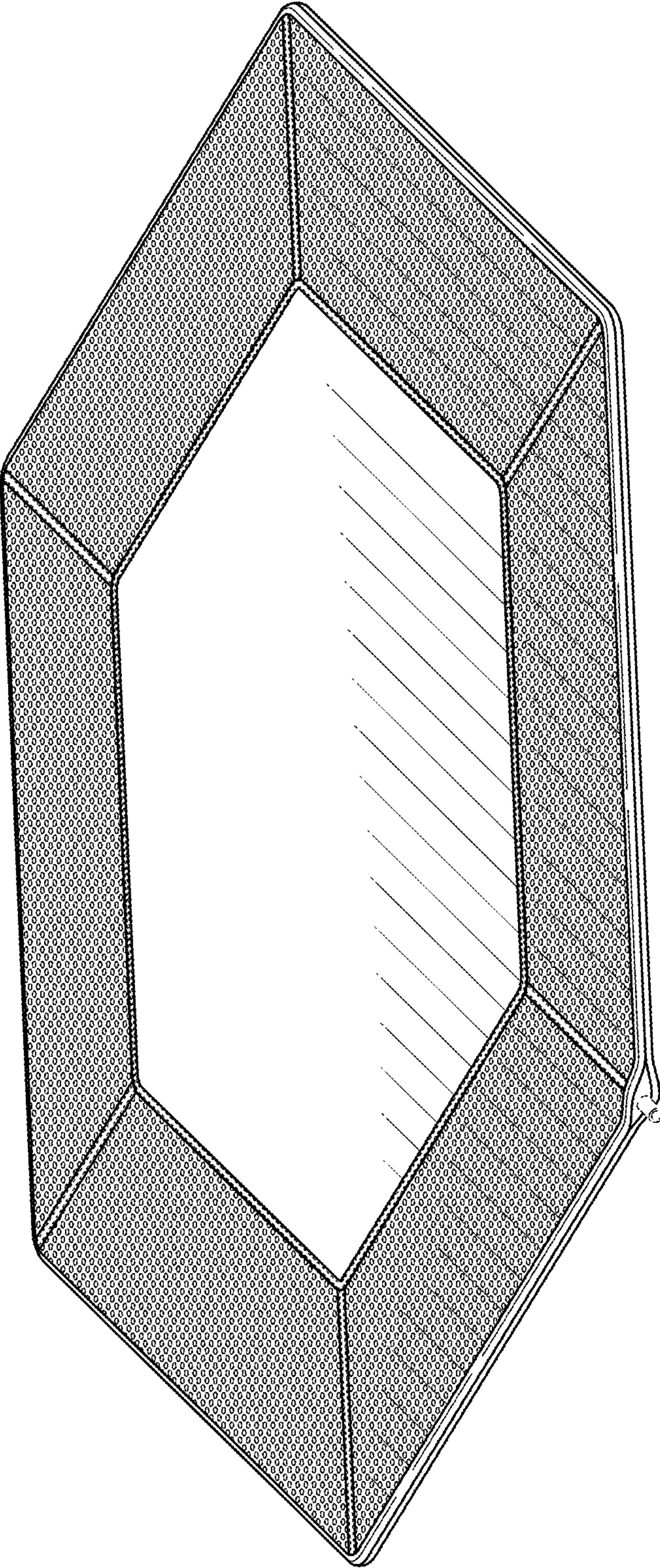

FIG. 1

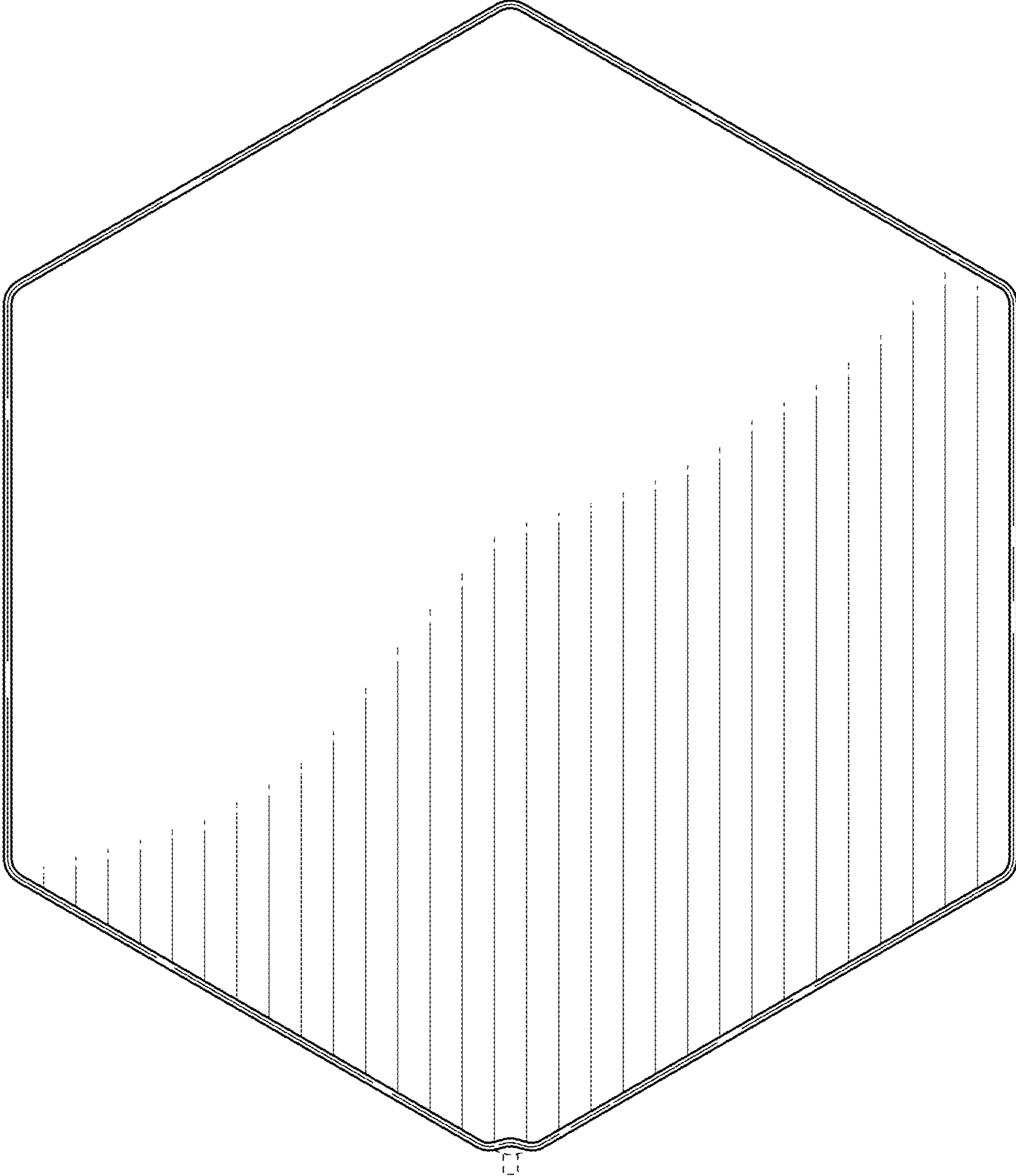

FIG. 2



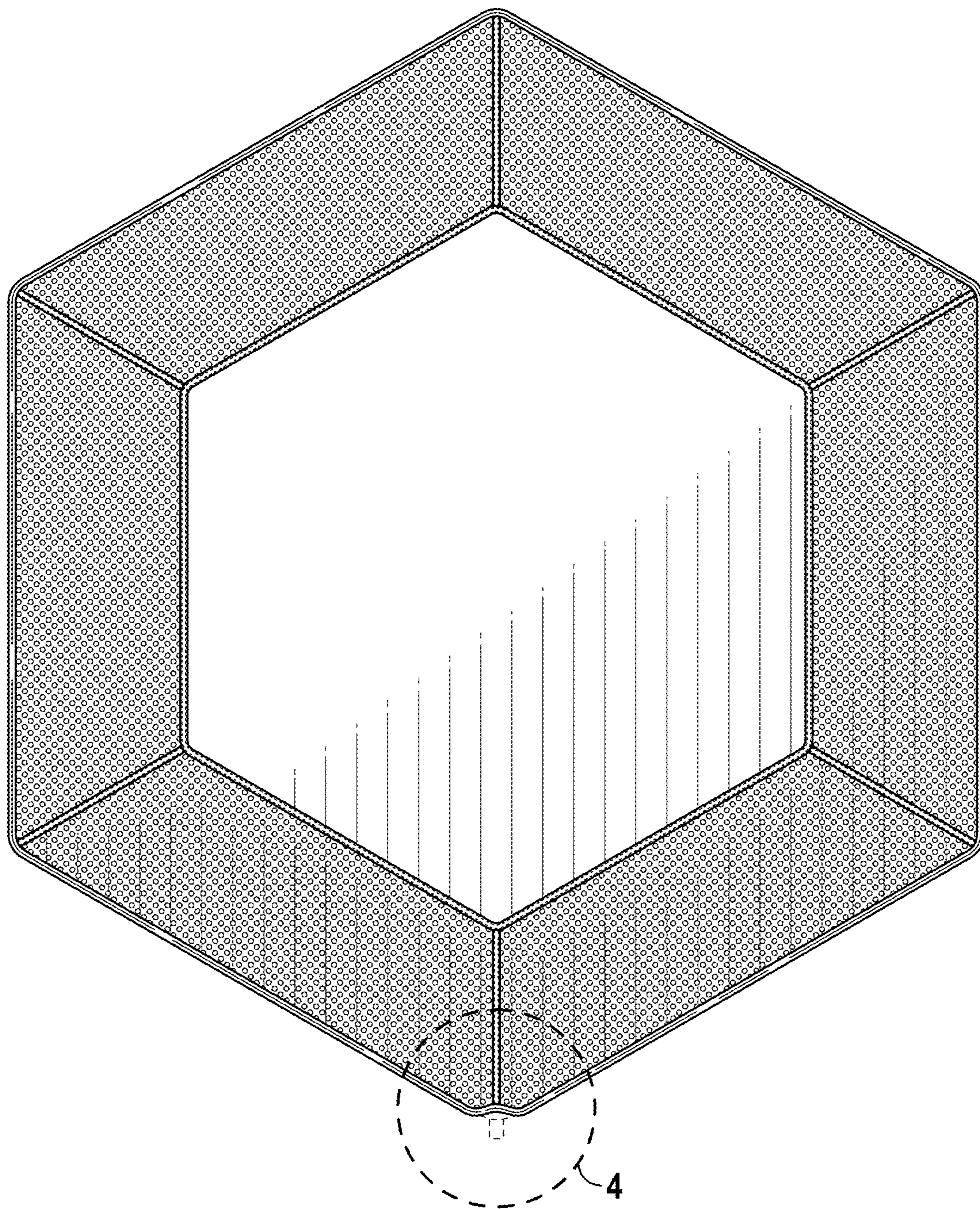

FIG. 3

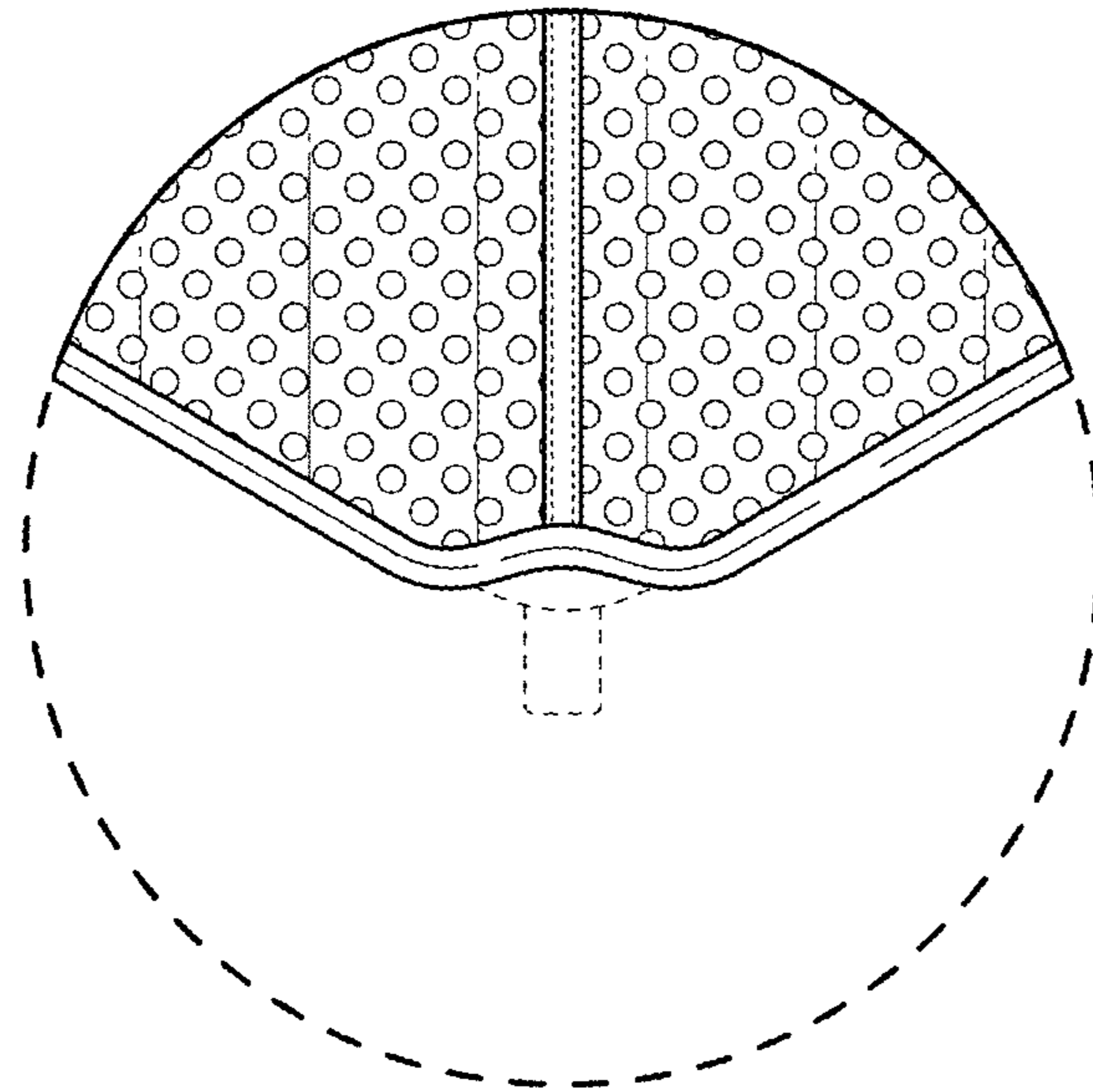

FIG. 4