



US00D943897S

(12) **United States Design Patent** (10) **Patent No.:** **US D943,897 S**
Gavrieli et al. (45) **Date of Patent:** **** *Feb. 22, 2022**

(54) **DUAL-SOLE SHOE WITH GREEN OUTSOLE PATCH**

(71) Applicant: **Gavrieli Brands LLC**, Beverly Hills, CA (US)

(72) Inventors: **Kfir Gavrieli**, Beverly Hills, CA (US); **Dikla Gavrieli**, Beverly Hills, CA (US)

(73) Assignee: **Gavrieli Brands LLC**, Beverly Hills, CA (US)

(*) Notice: This patent is subject to a terminal disclaimer.

(**) Term: **15 Years**

(21) Appl. No.: **29/731,297**

(22) Filed: **Apr. 14, 2020**

Related U.S. Application Data

(63) Continuation of application No. 29/681,343, filed on Feb. 25, 2019, now abandoned, which is a (Continued)

(51) **LOC (13) Cl.** **02-04**

(52) **U.S. Cl.**
USPC **D2/951; D2/947**

(58) **Field of Classification Search**
USPC D2/902, 906, 908, 916, 918, 925, D2/946-962, 977; 36/1, 1.5, 3 B, 22 R, (Continued)

(56) **References Cited**

U.S. PATENT DOCUMENTS

249,086 A 11/1881 Pienovi
773,850 A 11/1904 Cooper et al.
(Continued)

FOREIGN PATENT DOCUMENTS

DE 20 2006 000230 U1 5/2007
GB 2443937 A 5/2008
(Continued)

OTHER PUBLICATIONS

Examination Report for AU 341324, 3 pgs., dated Oct. 24, 2012.

(Continued)

Primary Examiner — Jonathan J Han

(74) *Attorney, Agent, or Firm* — Morgan, Lewis & Bockius LLP

(57) **CLAIM**

The ornamental design for a dual-sole shoe with green outsole patch, as shown and described.

DESCRIPTION

The file of this patent contains at least one drawing executed in color. Copies of this patent with color drawing(s) will be provided by the Office upon request and payment of the necessary fee.

FIG. 1 is a perspective view of an embodiment of our new design of a dual-sole shoe with green outsole patch, in which the outsole patches are hatched using the USPTO convention of solid diagonal lines extending from the upper left to the lower right for green;

FIG. 2 is a first side view of the design of FIG. 1;

FIG. 3 is a second side view of the design of FIG. 1;

FIG. 4 is a top view of the design of FIG. 1;

FIG. 5 is a bottom view of the design of FIG. 1;

FIG. 6 is a front view of the design of FIG. 1;

FIG. 7 is a back view of the design of FIG. 1;

FIG. 8 is a perspective view of another embodiment of our new design of a dual-sole shoe with green outsole patch;

FIG. 9 is a first side view of the design of FIG. 8;

FIG. 10 is a second side view of the design of FIG. 8;

FIG. 11 is a top view of the design of FIG. 8;

FIG. 12 is a bottom view of the design of FIG. 8;

FIG. 13 is a front view of the design of FIG. 8; and,

FIG. 14 is a back view of the design of FIG. 8.

The broken lines illustrating the upper, the half moon patch, the groove, and the heel stripe in the above described depict environment and form no part of the claimed design.

1 Claim, 12 Drawing Sheets
(5 of 12 Drawing Sheet(s) Filed in Color)

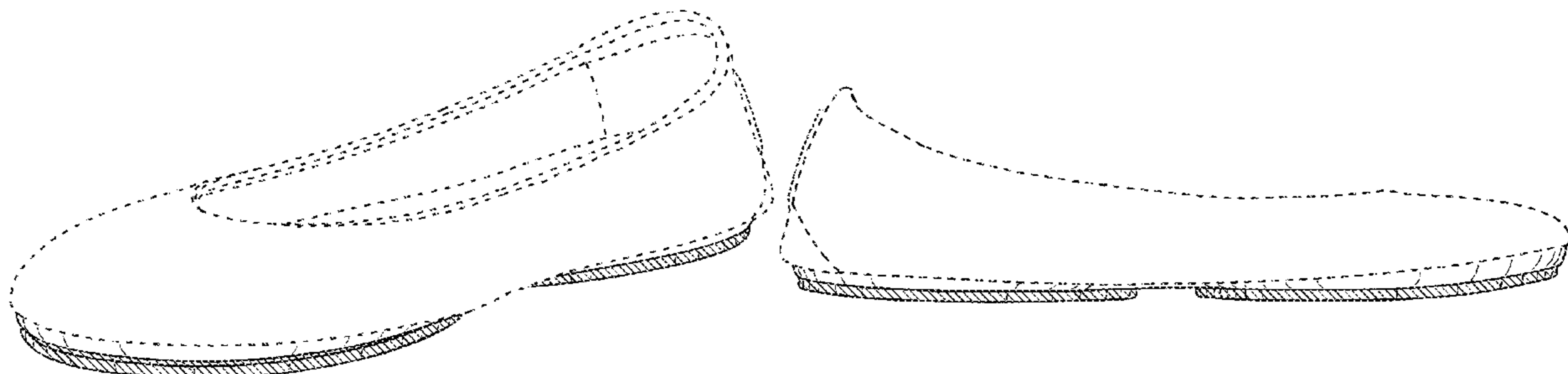

Related U.S. Application Data

continuation of application No. 29/509,246, filed on Nov. 14, 2014, now Pat. No. Des. 781,032, and a continuation of application No. 14/266,599, filed on Apr. 30, 2014, now Pat. No. 9,398,786, which is a continuation of application No. 13/207,397, filed on Aug. 10, 2011, now Pat. No. 8,745,893.

(58) **Field of Classification Search**

USPC 36/24.5, 25 R, 28, 32 R, 34 R, 59 C, 36/67 A, 101–107, 114–116, 117.3, 117.4, 36/124–136
 CPC A43B 13/00; A43B 13/02; A43B 13/023; A43B 13/026; A43B 13/04; A43B 13/08; A43B 13/10; A43B 13/12; A43B 13/14; A43B 13/141; A43B 13/143; A43B 13/16; A43B 13/18; A43B 13/181; A43B 13/187; A43B 13/189; A43B 13/20; A43B 13/22; A43B 13/223; A43B 13/24; A43B 13/28; A43B 13/30; A43B 13/32; A43B 13/34; A43B 13/36

See application file for complete search history.

(56) **References Cited**

U.S. PATENT DOCUMENTS

830,941 A 9/1906 Walden
 1,208,209 A 12/1916 Prince
 1,214,666 A 2/1917 Ford
 1,519,009 A 12/1924 Reina
 1,525,848 A 2/1925 Bonaventure
 1,587,377 A 6/1926 Grosjean
 1,650,466 A 11/1927 Righter
 2,224,590 A 12/1940 Boivin
 2,268,777 A 1/1942 Schöll
 D133,819 S 9/1942 Harris
 D135,791 S 6/1943 Beebe
 2,323,563 A 7/1943 Nugent
 2,342,882 A 2/1944 Meltzer
 D141,871 S 7/1945 Braun
 2,383,585 A 8/1945 Bindner
 D149,685 S 5/1948 Sandler
 D150,729 S 8/1948 Sandler
 D166,090 S 3/1952 Maling
 2,772,488 A 12/1956 Meltzer
 2,904,814 A 9/1959 Schöll
 3,148,378 A 9/1964 Tibbitts
 D200,897 S 4/1965 Mitchell
 D220,464 S 4/1971 Hayoshi
 D247,396 S 3/1978 Schlerth
 4,412,393 A 11/1983 Terlizzi, Jr. et al.
 D275,525 S 9/1984 Nakao
 4,674,206 A 6/1987 Lyden
 D295,692 S 5/1988 Zuidema et al.
 D300,085 S 3/1989 Ito et al.
 RE33,018 E 8/1989 Ostrander
 4,899,412 A 2/1990 Ganon
 D316,773 S 5/1991 Valle
 5,012,541 A 5/1991 Ganon
 D321,588 S * 11/1991 Issler D2/953
 D339,669 S 9/1993 Miller
 5,282,326 A 2/1994 Schroer, Jr. et al.
 5,421,050 A 6/1995 Laganas
 D387,546 S * 12/1997 Pearce D2/951
 5,699,629 A 12/1997 Munsch
 D390,351 S * 2/1998 Nevens D2/954
 5,746,014 A 5/1998 Tanemoto
 D405,596 S * 2/1999 Aird D2/957
 D405,944 S * 2/1999 Sessa D2/959
 D420,785 S 2/2000 Perez
 6,055,745 A 5/2000 Endoh
 6,076,284 A 6/2000 Terlizzi
 6,189,239 B1 2/2001 Gasparovic et al.
 6,338,207 B1 1/2002 Chang

D457,292 S 5/2002 Sessa
 D461,947 S 8/2002 Merceron
 D464,188 S * 10/2002 Lozano D2/951
 6,588,124 B2 6/2003 Morrone
 D476,798 S 7/2003 Reynolds et al.
 D482,851 S * 12/2003 McClaskie D2/947
 D495,477 S * 9/2004 McClaskie D2/947
 D498,041 S 11/2004 McClaskie
 D499,238 S * 12/2004 Romero-Sanchez D2/947
 D499,534 S * 12/2004 McClaskie D2/947
 D500,191 S 12/2004 Belley et al.
 D501,706 S 2/2005 McClaskie
 6,857,203 B2 2/2005 Minden
 6,895,693 B2 5/2005 Baruck
 6,978,557 B2 12/2005 Lee
 7,032,327 B1 4/2006 Tartaglia et al.
 7,036,244 B1 5/2006 Finch
 D527,513 S 9/2006 Della Valle
 D529,513 S 10/2006 Aketa
 D531,790 S 11/2006 Wurzburg
 D534,341 S 1/2007 Choi
 D540,016 S * 4/2007 McClaskie D2/953
 D542,513 S 5/2007 Amado et al.
 D553,332 S * 10/2007 McClaskie D2/951
 D556,990 S 12/2007 Cabados
 7,337,558 B2 3/2008 Terlizzi et al.
 D567,485 S 4/2008 James
 D570,488 S 6/2008 Kirksey et al.
 D571,084 S 6/2008 Comeau
 D571,548 S 6/2008 Seamans
 D571,989 S 7/2008 Siegal
 D580,640 S 11/2008 Wurzburg
 D582,638 S 12/2008 Ringholz
 7,496,982 B2 3/2009 Clark et al.
 7,506,459 B2 3/2009 Grisoni et al.
 D591,031 S 4/2009 Cofinco
 D593,295 S 6/2009 Belley et al.
 D593,297 S 6/2009 Belley et al.
 D593,307 S 6/2009 Belley et al.
 D594,196 S * 6/2009 Recchi D2/951
 D599,093 S 9/2009 Issler
 D604,030 S 11/2009 Wilson
 D607,194 S 1/2010 Zagula
 D610,332 S 2/2010 Raichle
 D610,785 S 3/2010 Smith
 D612,140 S 3/2010 Moon
 D612,141 S 3/2010 Moon
 7,694,435 B1 4/2010 Kiser et al.
 D615,737 S 5/2010 Feller
 7,735,244 B1 6/2010 Ameche
 7,743,530 B2 6/2010 Truelsen
 D618,891 S 7/2010 McClaskie
 7,757,408 B2 7/2010 McClaskie
 D630,829 S 1/2011 Weisner
 D632,881 S 2/2011 Rosenberg
 7,926,203 B2 4/2011 Wilkenfeld
 7,966,747 B2 6/2011 Wilkenfeld et al.
 D640,861 S 7/2011 Wilkenfeld
 D643,607 S * 8/2011 Teteriatnikov D2/954
 8,020,320 B2 9/2011 Gillespie
 8,127,468 B2 3/2012 Morgan
 D657,543 S 4/2012 Bove
 D659,960 S 5/2012 Bizzo
 8,230,619 B2 7/2012 Salvatelli
 D664,755 S 8/2012 Gavrieli et al.
 D665,157 S 8/2012 Wu
 8,240,067 B2 8/2012 Sussmann
 8,245,420 B2 8/2012 Wilson
 D668,027 S 10/2012 Millieret
 D668,438 S 10/2012 Millieret
 D668,847 S 10/2012 Gavrieli et al.
 D668,848 S 10/2012 Gavrieli et al.
 D668,849 S 10/2012 Pozzi
 D668,850 S 10/2012 Pozzi
 D669,674 S 10/2012 Vidal
 D672,542 S 12/2012 Gray et al.
 D676,634 S 2/2013 Gavrieli et al.
 D679,900 S 4/2013 Taestensen
 D681,927 S 5/2013 Gavrieli et al.

(56)

References Cited

U.S. PATENT DOCUMENTS

D681,928 S 5/2013 Gavrieli et al.
 D681,929 S 5/2013 Gavrieli et al.
 D683,936 S 6/2013 Gavrieli
 8,468,723 B2 6/2013 Malka-Harari
 D686,812 S 7/2013 Gavrieli et al.
 8,510,975 B2 8/2013 Krikelis
 D688,853 S 9/2013 Gavrieli et al.
 D688,854 S 9/2013 Gavrieli et al.
 D688,855 S 9/2013 Gavrieli et al.
 D689,270 S 9/2013 Gavrieli et al.
 D689,271 S 9/2013 Gavrieli et al.
 D689,272 S 9/2013 Gavrieli et al.
 D689,676 S 9/2013 Takamoto
 D690,914 S 10/2013 Gavrieli
 D690,915 S * 10/2013 Gavrieli A43B 9/02
 D2/939
 D690,919 S 10/2013 Takamoto
 D696,500 S 12/2013 Hunt
 D699,424 S 2/2014 Hamm
 D701,025 S 3/2014 McClaskie
 8,661,714 B2 3/2014 Sussman
 8,745,893 B2 6/2014 Gavrieli et al.
 D716,026 S 10/2014 Hazzouri
 8,973,287 B2 3/2015 Shibata
 D728,209 S 5/2015 Mansouri
 D737,028 S 8/2015 Bizzo
 9,167,862 B2 10/2015 Gavrieli
 D751,280 S 3/2016 Vasquez
 D755,492 S 5/2016 Bizzo
 D756,081 S 5/2016 Gavrieli
 D756,082 S 5/2016 Gavrieli
 D756,083 S 5/2016 Gavrieli
 D756,087 S 5/2016 Gavrieli
 D756,096 S 5/2016 Bizzo
 D761,532 S 7/2016 Gavrieli
 D761,533 S 7/2016 Gavrieli
 D761,534 S 7/2016 Gavrieli
 D761,535 S 7/2016 Gavrieli
 D761,537 S 7/2016 Gavrieli
 D761,538 S 7/2016 Gavrieli
 D761,539 S 7/2016 Gavrieli
 D762,050 S 7/2016 Gavrieli
 9,398,786 B2 7/2016 Gavrieli
 D768,366 S * 10/2016 Hawthornthwaite D2/939
 D793,676 S * 8/2017 Slimane D2/902
 D794,928 S * 8/2017 Fu D2/953
 D804,156 S * 12/2017 Hawthornthwaite D2/939
 D805,276 S * 12/2017 Hawthornthwaite D2/939
 10,258,121 B2 * 4/2019 Gavrieli A45C 3/12
 D851,872 S * 6/2019 Gavrieli D2/939
 D853,091 S * 7/2019 Gavrieli D2/939
 D853,092 S * 7/2019 Gavrieli D2/939
 D853,697 S * 7/2019 Gavrieli D2/939
 D853,698 S * 7/2019 Gavrieli D2/939
 D884,323 S * 5/2020 Gavrieli D2/951
 D885,018 S * 5/2020 Gavrieli D2/939
 D891,047 S * 7/2020 Gavrieli D2/939
 D901,862 S * 11/2020 Gavrieli D2/950
 2002/0078591 A1 6/2002 Morrone
 2002/0129519 A1 9/2002 Cahan
 2003/0070319 A1 4/2003 Minden
 2003/0121176 A1 7/2003 Baruck
 2004/0025377 A1 2/2004 Brannon
 2005/0022421 A1 2/2005 Bruckner
 2005/0115115 A1 6/2005 Lacey
 2005/0217148 A1 10/2005 Connolly et al.
 2005/0262734 A1 12/2005 Cheng
 2006/0086005 A1 4/2006 Yerian
 2006/0156576 A1 7/2006 Sloan
 2007/0074424 A1 4/2007 Lin
 2007/0204482 A1 9/2007 Gibson-Collinson
 2007/0204483 A1 9/2007 Kirsch et al.
 2008/0052964 A1 3/2008 Taylor
 2008/0086912 A1 4/2008 Wilkenfeld
 2008/0110059 A1 5/2008 Kuramoto et al.

2009/0019732 A1 1/2009 Sussmann
 2009/0193685 A1 8/2009 Wilson
 2009/0205222 A1 8/2009 McLinden
 2009/0272009 A1 11/2009 Weisner et al.
 2010/0011625 A1 1/2010 Percival
 2010/0018080 A1 1/2010 Smith
 2010/0050469 A1 3/2010 Chen
 2010/0095557 A1 4/2010 Jarvis
 2010/0115793 A1 5/2010 Kraisosky
 2010/0122475 A1 5/2010 Purrington
 2010/0146822 A1 6/2010 MacGregor
 2010/0212186 A1 8/2010 Cheng
 2010/0275462 A1 11/2010 Pucci
 2010/0281713 A1 11/2010 Pantazes
 2011/0010965 A1 1/2011 Shepherd
 2011/0214312 A1 9/2011 Krikelis
 2013/0036630 A1 2/2013 Gavrieli
 2013/0039605 A1 * 2/2013 Gavrieli A45C 3/12
 383/37
 2014/0075779 A1 3/2014 Bruce
 2014/0144045 A1 5/2014 Padilla
 2014/0310990 A1 10/2014 Su
 2015/0089843 A1 4/2015 Gavrieli

FOREIGN PATENT DOCUMENTS

GB 2 446 205 A 8/2008
 TW D119165 10/2007

OTHER PUBLICATIONS

Letter from TMI and Associates with Office Action, 2 pgs, dated Sep. 19, 2012 <http://www.payless.com/store/?&TLC=Womens&SLC=WomensNewArrivals&BLC=WomensNewArrivalsNewArrivals&With+Regular&ItemCode=60131&LotNumber=062642&Type=Adult&Popularity=637&Descriptvein>.
 Taiwanese Office Action for TW 101300726, 10 pgs., dated Sep. 6, 2012.
 “The Love List, Tiefs by Gavrieli—Foldable Ballet Flats,” <http://thelovelist-carly.blogspot.com.au/2010/09/tiefs-by-gavrieli-foldable-ballet.html>, 3 pgs., Sep. 12, 2010.
 “Tiefs by Gavrieli,” <http://tiefs.com>, 1 pg., retrieved Mar. 13, 2013 from URL.
 “Try It Mummy!, Tiefs by Gavrieli,” <http://tryitmummy.blogspot.com.au/2010/12/tiefs-by-gavrieli.html>, 4 pgs., Dec. 9, 2010.
 “Wearability—Real People Style, What came first, the City Flat or the Tiefs,” <http://wearability.posterous.com/what-came-first-the-city-flat-or-the-tiefs>. 4 pgs., Aug. 29, 2010.
 “The Ballet Flat . . . Reinvented; Ballet Flats . . . with a Bonus; Step Into Tiefs; Going Places? Take Tiefs,” <http://web.archive.org/web/2010052004346/http://www.tiefs.com/>; 4 pgs., May. 24, 2010.
 “Tiefs—Comfortable designer flats you can fit in your purse and wear all day, every day,” <http://web.archive.org/web/20110731151555/http://tiefs.com/>; 6 pgs., Jul. 31, 2011.
 “58th Annual Emmy Awards,” http://spoonsforksandfashion.blogspot.com/2006_08_01_archive.html, depicting Nine West flats, 11 pgs., Aug. 1, 2006.
 Pictures of Nine West flats sold in 2006, 3 pgs.
 “I Love a Good Ballet Flat!,” <http://dressupfiles.com/i-love-a-good-ballet-flat>, depicting Sue London flats, 4 pgs., Sep. 3, 2010.
 Pictures of Sue London flats sold in 2010, 2 pgs.
 “Miss Cathie Reviews: The Yosi Samra Foldable Ballet Flat . . .,” <http://www.misscathie.com/2010/01/miss-cathie-reviews-the-yosi-samra-foldable-ballet-flat/>, depicting Yosi Samra flats, 7 pgs., Jan. 2010.
 Pictures of Yosi Samra flats sold in 2010, 2 pgs.
 “Goodbye two thousand ten,” http://emmajoyrussell.blogspot.com/2010_12_01_archive.html, depicting Gap flats, 39 pgs., Dec. 1, 2010.
 Pictures of Gap flats available for sale in 2010, 9 pgs.
 “Our newest design of folding flats-Pink,” <https://fitinclouds.wordpress.com/2010/05/16/our-newest-design-of-folding-flats-pink/>, depicting Fit in Clouds flats, 1 pg., May 16, 2010.

(56)

References Cited

OTHER PUBLICATIONS

“Fit in Clouds Satin Folding Shoes,” <http://www.goodhousekeeping.com/product-reviews/clothing/best-ballet-flats/fit-in-clouds-satin-foldable-ballet-flats>, depicting Fit in Clouds flats, 1 pg., Aug. 2013. Pictures of Fit in Clouds flats available for sale in 2011, 4 pgs.

“Shoes for Standing,” <https://truthinshoes.wordpress.com/2008/07/>, depicting Sam & Libby flats, 2 pgs., Jul. 31, 2008.

“Target Designer Collaboration: Announcing Sam & Libby Shoes for Target,” <http://www.therecessionista.com/2012/11/target-designer-collaboration-announcing-sam-libby-shoes-for-target.html>, depicting Sam & Libby flats, 1 pg., Nov. 26, 2012. Pictures of Sam & Libby flats available for purchase in 2011, 5 pgs.

“Save your soles with Citisoles ballet flats,” <http://glamazondiaries.com/2009/07/save-your-soles-with-citisoles-ballet-flats>, depicting Citisoles flats, 3 pgs., Jul. 2009. Pictures of Citisoles flats available for purchase in 2009, 3 pgs.

“#16 Corso Como Delicious Pumps Review and Giveaway!,” <http://www.mommatoldmeblog.com/2011/01/16-corso-como-delicious-pumps-review.html>, depicting Corso Como flats, 8 pgs., Jan. 16, 2011. Pictures of Corso Como flats available for sale in 2011, 3 pgs.

“Jil-sander-navy-lead-ballet-flats-product . . . ,” www.ebay.com, depicting Jil Sander flats, 4 pgs., Nov. 2013. Pictures of Jil Sander flats available for sale in 2011, 3 pgs.

“Spare Soles: Shoes That Roll-up & Fold-up,” <http://herpackinglist.com/2011/01/spare-soles-shoes/>, depicting Spare Soles flats, 2 pgs., Jan. 2011. Pictures of Spare Soles flats available for sale in 2011, 5 pgs.

The Original Rollable, Foldable ballet flats with matching wristlet—Spare Soles, <http://herpackinglist.com/2011/01/spare-soles-shoes/>, depicting Roll-Upz Spare Soles flats, 2 pgs., Jan. 2011. Pictures of Roll-Upz by Spare Soles flats available for sale in 2011, 6 pgs.

“The Cutest Blog, Preppy 50 and Loving Lilly, Ballet Flat Delight,” <http://preppy50andlovinglilly.blogspot.com/2011/02/ballet-flat-delight.html>, depicting Henri Bendel flats, 13 pgs., Feb. 19, 2011. Pictures of Henri Bendel flats available for sale in 2011, 4 pgs.

“Mumsnet by parents for parents,” http://www.mumsnet.com/Talk/style_and_beauty/al612000-Anyone-tried-Redfoot-Flatmates-foldable-ballet-pumps, depicting Redfoot Flatmates flats, 1 pg, Nov. 14, 2012. Pictures of Redfoot Flatmates flats available for sale in 2011, 6 pgs.

“Amazon.com: Customer Reviews: Bloch London Women’s Lux Ballet Flat,” <http://www.amazon.com/Bloch-London-Womens-Ballet-Flat/product-reviews/B004LWP7YW>, depicting Bloch London flats, 4 pgs., Dec. 11, 2011. Pictures of Bloch London flats offered for sale in 2011, 11 pgs.

“h&m foldable leopard print flat,” <http://845shops.wordpress.com/2011/06/16/flats-for-7-bucks/shoe1/>, depicting h&m flats, 3 pgs., Jun. 16, 2011. Pictures of h&m foldable flats offered for sale in 2011, 4 pgs.

“Seekyt—Juicy Couture Ballet Flats—Are They Worth The Money?,” <http://seekyt.com/juicy-couture-ballet-flats-are-they-worth-the-money/>, 14 pgs., Jun. 3, 2011. Pictures of Juicy Couture flats offered for sale in 2011, 3 pgs.

“Purse Flats,” <http://purseflats.wordpress.com>, depicting Purse Flats by Erica Wilson, 3 pgs., Jul. 12, 2012. Pictures of Purse Flats by Erica Wilson offered for sale in 2011, 6 pgs.

“Splash Page,” <http://web.archive.org/web/20100524004346/http://www.tieks.com/>, 4 pgs., May 24, 2010.

“Tieks by Gavrieli—Comfortable, designer flats you can fit in your purse and wear all day . . . ,” <http://web.archive.org/web/20110202210649/http://www.tieks.com/>, 8 pgs., Feb. 2, 2011.

“Carolina M. M. Gonzalez > Tieks by Gavrieli,” http://m2.facebook.com/Tieks?y=timeline&filter=2&timecutoff=1406427986&page=17§ionLoadingID=m_timeline_loading_div_1293868799_1262332800_8_17&timeend=1293868799×tart=1262332800&tm=AQDOvqhWQPN_Nbwm&refid=17, 1 pg. Jan. 26, 2010.

“The Shoes Oprah Would Wear to Work (if She Had to Walk),” <http://www.inc.com/30under30/christina-desmarais/kfir-gavrieli-and-elram-gavrieli-founders-of-tieks.html>, 8 pgs., Jul. 2, 2012.

“Tieks by Gavrieli,” http://m2.facebook.com/Tieks?v=timeline&filter=2&timecutoff=1406427986&page=14§ionLoadingID=m_timeline_loading_div_1293868799_1262332800_8_14&timeend=1293868799×tart=1262332800&tm=AQDOvqhWQPN_Nbwm&refid=17, 4 pgs., Jan. 26, 2010.

“Mighty Life List, Sensible Shoes,” <http://mighty-girl.com/2010/08/24/sensible-shoes/>, 10 pgs., Aug. 24, 2010.

“Find! Tieks: Fab & sexy flats for fall,” <http://thefabmom.com/2013/08/29/find-tieks-fab-sexy-flats-for-fall/>, 3 pgs. Aug. 29, 2013.

“Step into Tieks,” <http://sliceofpink.typepad.com/blog/2010/09/tieks-1.html>, 5 pgs., Sep. 22, 2010.

“In Need of Flat-Soled Shoes,” <http://sliceofpink.typepad.com/blog/2010/09/tieks-1.html>, 7 pgs., Oct. 3, 2010.

“Say Hello to the Flat Shoes You Need for Fall . . . All 88 of Them!”, Picture of Adam Tucker Shoe/Slipper, <https://www.facebook.com/search/top/?q=adam%20shoes%20slipper>, last accessed Oct. 28, 2016, dated Oct. 1, 2013, 1 page. Picture of Adam Tucker Rainbow Shoes, <https://www.facebook.com/search/top/?q=adam%20shoes%20rainbow>, last accessed Oct. 28, 2016, dated Aug. 14, 2013, 1 page.

Third Party Submission Under 37 CFR 1.290 regarding U.S. Appl. No. 15/905,239, Feb. 9, 2019, 94 pages.

Order Granting TRO (D.I. 11), *Gavrieli Brands LLC vs. Soto Massini*, Civil Action No. 1:18-cv-00462, Mar. 28, 2018, 2 pages.

Defendants’ Opposition To Motion For Temporary Restraining Order, Civil Action No. 1:18-cv-00462-GMS, Apr. 1, 2018, 12 pages.

Declaration of Thomas Pichler In Opposition To Tro Request, C.A. No. 1:18-cv-00462-GMS, Apr. 1, 2018, 8 pages.

Exhibit A to Pichler Declaration ISO TRO Opposition (D.I. 13-1), C.A. No. 1:18-cv-00462-GMS, Apr. 1, 2018, 29 pages.

Order TRO (D.I. 18), C.A. No. 1:18, Apr. 4, 2018, 3 pages.

Defendant Soto Massini (USA) Corporation’s Answer and Counterclaims To Verified Complaint for Patent Infringement, Trade Dress Infringement, and Unfair Competition, C.A. No. 1:18-cv-00462-GMS, May 1, 2018, 26 pages.

Defendant Soto Massini (USA) Corporation’s Answer To Amended Complaint and Amended Counterclaims, C.A. No. 1:18-cv-00462-GMS, Jun. 5, 2018, 28 pages.

Defendant Soto Massini (USA) Corporation’s Answer To Amended Complaint and First Amended Counterclaims, C.A. No. 1:18-cv-00462-GMS, Jul. 12, 2018, 31 pages.

Exhibit A to SACC (45-1), Case 1:18-cv-00462-GMS, 3 pages.

Exhibit B to SACC (45-2), Case 1:18-cv-00462-GMS, 5 pages.

Exhibit C to SACC (45-3), Case 1:18-cv-00462-GMS, 5 pages.

Exhibit D to SACC (45-4), Case 1:18-cv-00462-GMS, 4 pages.

Defendant Soto-USA’s Invalidity Contentions, C.A. No. 1:18-cv-00462-MN, 16 pages.

Redacted Verdict Form (D.I. 144), Case 1:18-cv-00462-GMS, 13 pages.

Judgement (D.I. 149), C.A. No. 18-462-MN, May 13, 2019, 3 pages.

Gavrieli Brands, LLC, v. Soto Massini (USA) Corp., et al., (full) Trial Transcript, C.A. No. 18-462(MN), vol. 1, 733 pages.

Expert Report of Caroline de Baere (Fed. R. CIV. P. 26(a)(2)(B), Case No. 18-cv-00462-MN, Mar. 1, 2019, 33 pages.

Exhibit 23, Infringement Analysis in Light of the Alleged Prior Art, 41 pages.

Expert Report of Lance Rake, (Fed. R. CIV. P. 26(a)(2)(B), Mar. 1, 2019, 27 pages.

U.S. Pat. No. 1,525,848, Feb. 10, 1925, B. S. Bonaventure, 3 pages.

Design U.S. Pat. No. 247,396, Mar. 7, 1978, William A. Schlerth, 2 pages.

Design U.S. Pat. No. D. 611,693 S, Mar. 16, 2010, Barbara Schwartz, 7 pages.

Camper Book Excerpt—Nina Right, (pp. 334-335), The Walking Society, Lars Müller Publishers, 3 pages.

Camper History—The Shoes, Every Season We Strive To Reinvent Some Of Our Classic Concepts While Continuing To Challenge The

(56)

References Cited

OTHER PUBLICATIONS

Status Quo With New And Original Designs. We Often Find That There Is A Camper Style For Every Walk Of Life, 8 pages.

Tieks by Gavrieli—Comfortable, designer flats you can fit in your purse and wear all day, every day!, Copperhead Snake Print Tieks, <https://web.archive.org/web/20101230062534/http://www.tieks.com:80/>, Dec. 30, 2010, 1 page.

Tieks by Gavrieli—Comfortable, designer flats you can fit in your purse and wear all day, every day!, Merlot Lizard Print Tieks, <https://web.archive.org/web/20101230062534/http://www.tieks.com:80/>, Dec. 30, 2010, 1 page.

Tieks by Gavrieli—Comfortable, designer flats you can fit in your purse and wear all day, every day!, Slate Grey Tieks, <https://web.archive.org/web/20101230062534/http://www.tieks.com:80/>, Dec. 30, 2010, 1 page.

Tieks by Gavrieli—Comfortable, designer flats you can fit in your purse and wear all day, every day!, Camel, <https://web.archive.org/web/20101230062534/http://www.tieks.com:80/>, Dec. 30, 2010, 1 page.

Tieks by Gavrieli—Comfortable, designer flats you can fit in your purse and wear all day, every day!, Lilac, <https://web.archive.org/web/20101230062534/http://www.tieks.com:80/>, Dec. 30, 2010, 1 page.

Tieks by Gavrieli—Comfortable, designer flats you can fit in your purse and wear all day, every day!, Leopard Print, <https://web.archive.org/web/20101230062534/http://www.tieks.com:80/>, Dec. 30, 2010, 1 page.

Tieks by Gavrieli—Comfortable, designer flats you can fit in your purse and wear all day, every day!, The Tieks eGift card . . . Always the perfect fit, <https://web.archive.org/web/20101230062534/http://www.tieks.com:80/>, Dec. 30, 2010, 1 page.

Tieks by Gavrieli—Comfortable, designer flats you can fit in your purse and wear all day, every day!, Copperhead Snake Print, <https://web.archive.org/web/20110222174850/http://www.tieks.com:80/>, Feb. 22, 2011, 1 page.

Tieks by Gavrieli—Comfortable, designer flats you can fit in your purse and wear all day, every day!, Patent Tiek Blue, <https://web.archive.org/web/20110222174850/http://www.tieks.com:80/>, Feb. 22, 2011, 1 page.

Tieks by Gavrieli—Comfortable, designer flats you can fit in your purse and wear all day, every day!, Tangerine, <https://web.archive.org/web/20110222174850/http://www.tieks.com:80/>, Feb. 22, 2011, 1 page.

Tieks by Gavrieli—Fashionable Flats That Fit in Your Purse California Navy, <https://web.archive.org/web/20100516173039/http://www.tieks.com:80/california-navy.html>, May 16, 2010, 1 page.

Tieks by Gavrieli—Fashionable Flats That Fit in Your Purse Cardinal Red, <https://web.archive.org/web/20100516173045/http://www.tieks.com:80/cardinal-red.html>, May 16, 2010, 1 page.

Tieks by Gavrieli—Fashionable Flats That Fit in Your Purse Metallic Gold, <https://web.archive.org/web/20100516173106/tieks.com/metallic-gold.html>, May 16, 2010, 1 page.

Tieks by Gavrieli—Fashionable Flats That Fit in Your Purse Patent Tiek Blue, <https://web.archive.org/web/20100516173130/http://www.tieks.com:80/tiek-blue.html>, May 16, 2010, 1 page.

Tieks by Gavrieli—Fashionable Flats That Fit in Your Purse Splash Page, The Ballet Flat . . . Reinvented, <https://web.archive.org/web/20100513055818/https://tieks.com/>, May 13, 2010, 1 page.

Tieks by Gavrieli—Fashionable Flats That Fit in Your Purse Splash Page, Ballet Flats . . . with a Bonus, <https://web.archive.org/web/20100513055818/https://tieks.com/>, May 13, 2010, 1 page.

Tieks by Gavrieli—Fashionable Flats That Fit in Your Purse Splash Page, Going Places? Take Tieks. <https://web.archive.org/web/20100513055818/https://tieks.com/>, May 13, 2010, 1 page.

Tieks by Gavrieli—Fashionable Flats That Fit in Your Purse Splash Page, Step Into Tieks, <https://web.archive.org/web/20100513055818/https://tieks.com/>, May 13, 2010, 1 page.

Tieks by Gavrieli—Fashionable Flats That Fit in Your Purse True Blue, <https://web.archive.org/web/20100516173135/http://www.tieks.com:80/true-blue.html>, May 16, 2010, 1 page.

Tieks by Gavrieli—Fashionable Flats That Fit in Your Purse White Croc Print, <https://web.archive.org/web/20100516173145/http://www.tieks.com:80/white-croc-print.html>, May 16, 2010, 1 page.

Tieks by Gavrieli—Foldable Fashionable Ballet Flats, Wild Copper, Be a little wild . . . even when you're not., <https://web.archive.org/web/20100819165503/https://tieks.com/>, Aug. 19, 2010, 1 page.

Tieks by Gavrieli—Foldable Fashionable Ballet Flats, Paradise Blue, The perfect pair for day and night, <https://web.archive.org/web/20100819165503/https://tieks.com/>, Aug. 19, 2010, 1 page.

Tieks by Gavrieli—Foldable Fashionable Ballet Flats, Obsidian Black, When workdays spill over into party nights., <https://web.archive.org/web/20100819165503/https://tieks.com/>, Aug. 19, 2010, 1 page.

Tieks by Gavrieli—Foldable Fashionable Ballet Flats, Fuchsia, Sweet and sultry, <https://web.archive.org/web/20100819165503/https://tieks.com/>, Aug. 19, 2010, 1 page.

Tieks by Gavrieli—Foldable Fashionable Ballet Flats, Tan Croc print Tieks, A timeless texture., <https://web.archive.org/web/20100819165503/https://tieks.com/>, Aug. 19, 2010, 1 page.

Tieks by Gavrieli—Foldable Fashionable Ballet Flats, Be a little wild . . . even when you're not., <https://web.archive.org/web/20100902020755/https://tieks.com/>, Sep. 2, 2010, 1 page.

Tieks by Gavrieli—Foldable Fashionable Ballet Flats, Obsidian Black, When workdays spill over into party nights. <https://web.archive.org/web/20100902020755/https://tieks.com/>, Sep. 2, 2010, 1 page.

Tieks by Gavrieli—Foldable Fashionable Ballet Flats, Tan Croc Print, A timeless texture, <https://web.archive.org/web/20100902020755/https://tieks.com/>, Sep. 2, 2010, 1 page.

Tieks by Gavrieli—Foldable Fashionable Ballet Flats, Paradise Blue, The perfect pair for day and night, <https://web.archive.org/web/20100902020755/https://tieks.com/>, Sep. 2, 2010, 1 page.

Tieks by Gavrieli—Foldable Fashionable Ballet Flats, Fuchsia, Sweet and sultry, <https://web.archive.org/web/20100902020755/https://tieks.com/>, Sep. 2, 2010, 1 page.

Tieks by Gavrieli—Foldable Fashionable Ballet Flats, Tiek Blue Tieks, Let yourself shine, <https://web.archive.org/web/20100902020755/https://tieks.com/>, Sep. 2, 2010, 1 page.

* cited by examiner

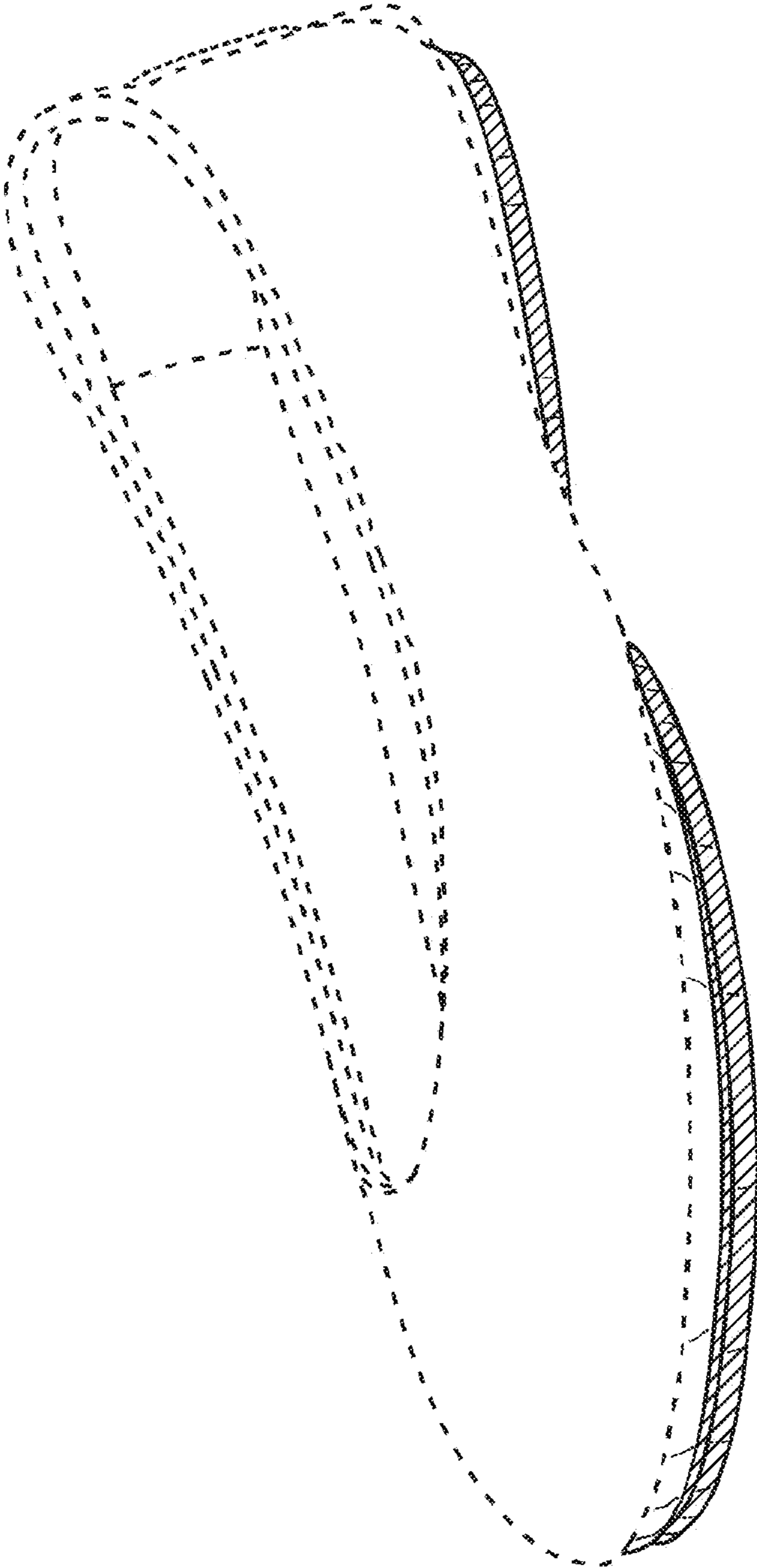

FIG. 1

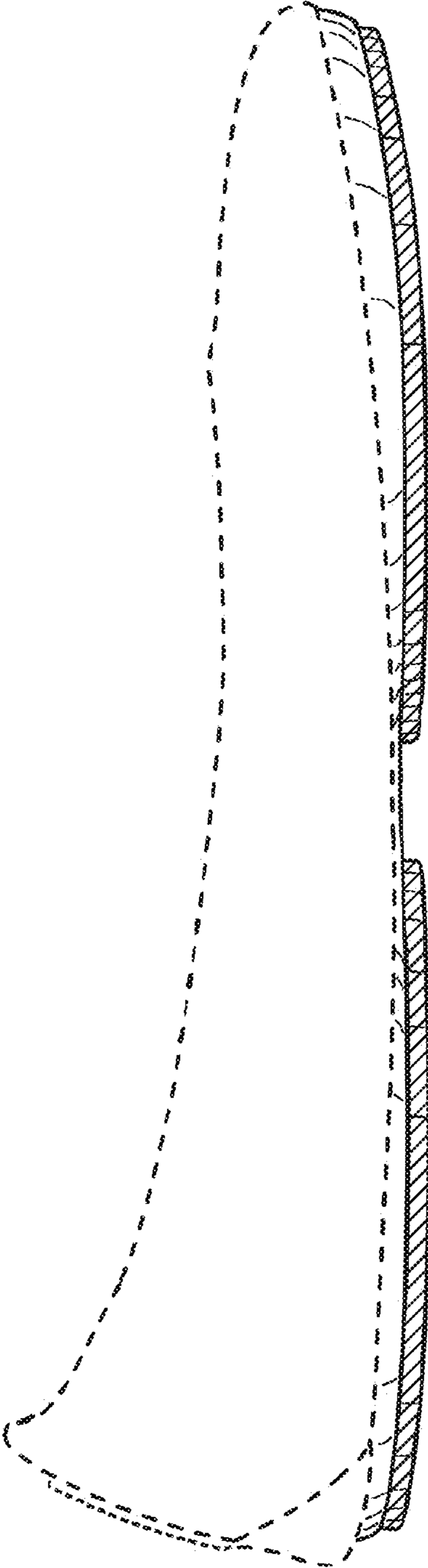

FIG. 2

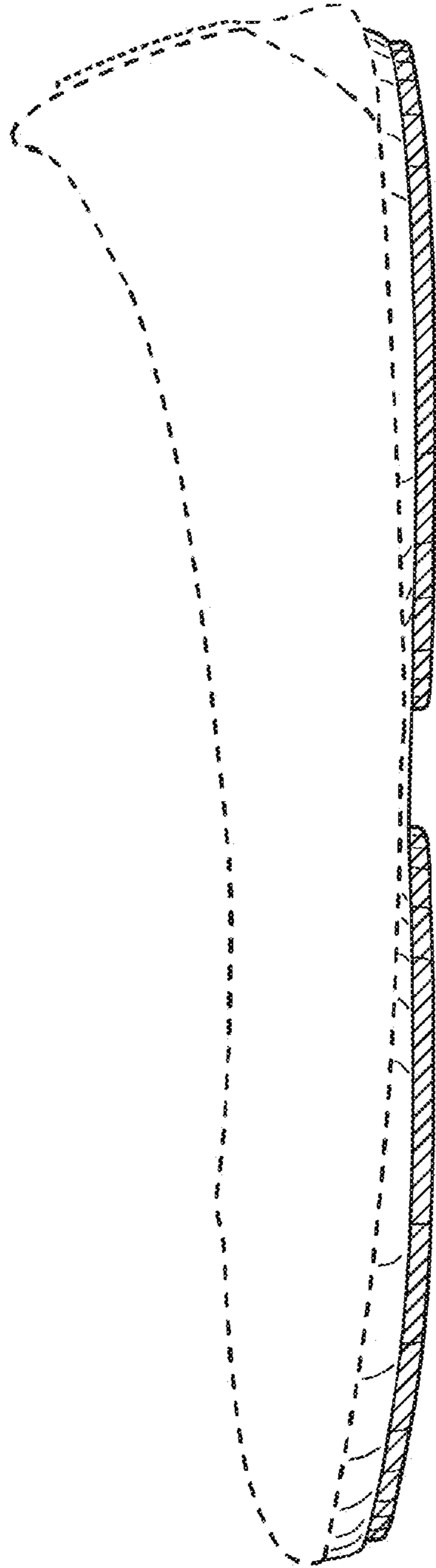

FIG. 3

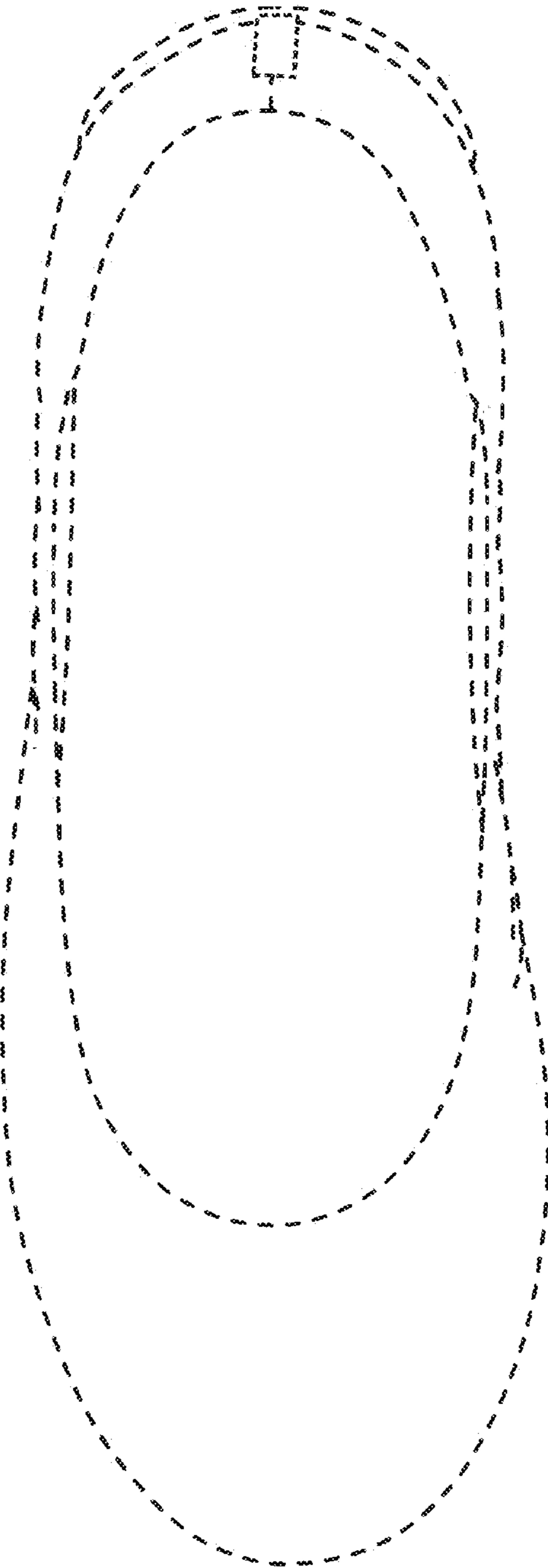

FIG. 4

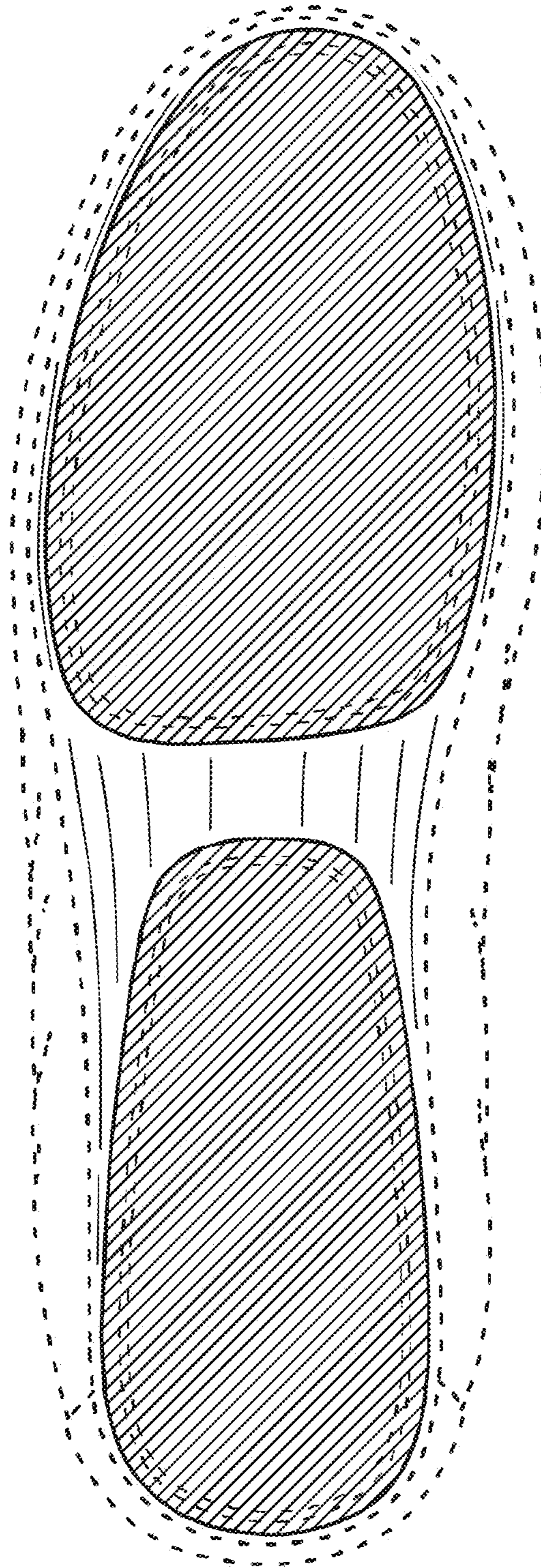

FIG. 5

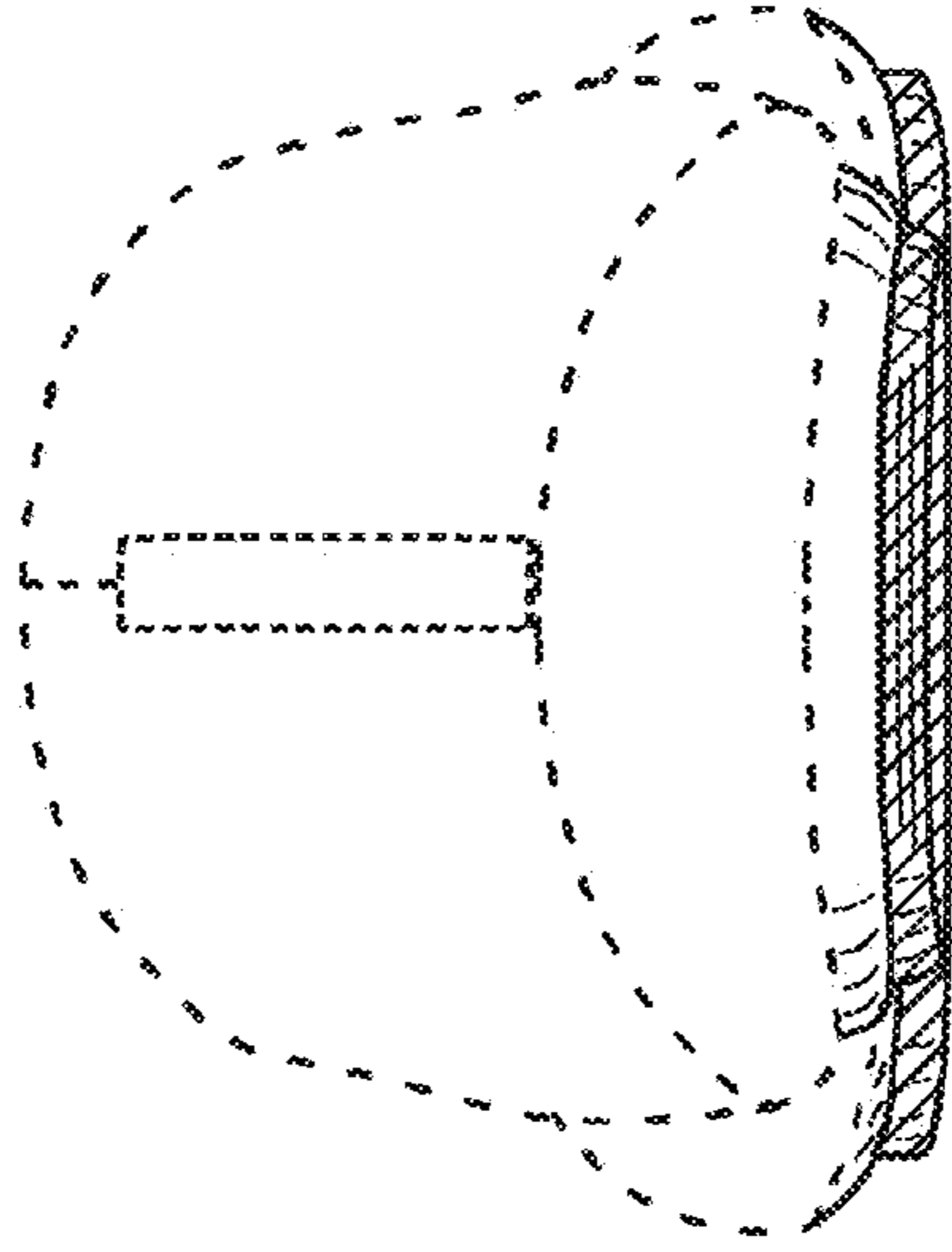

FIG. 7

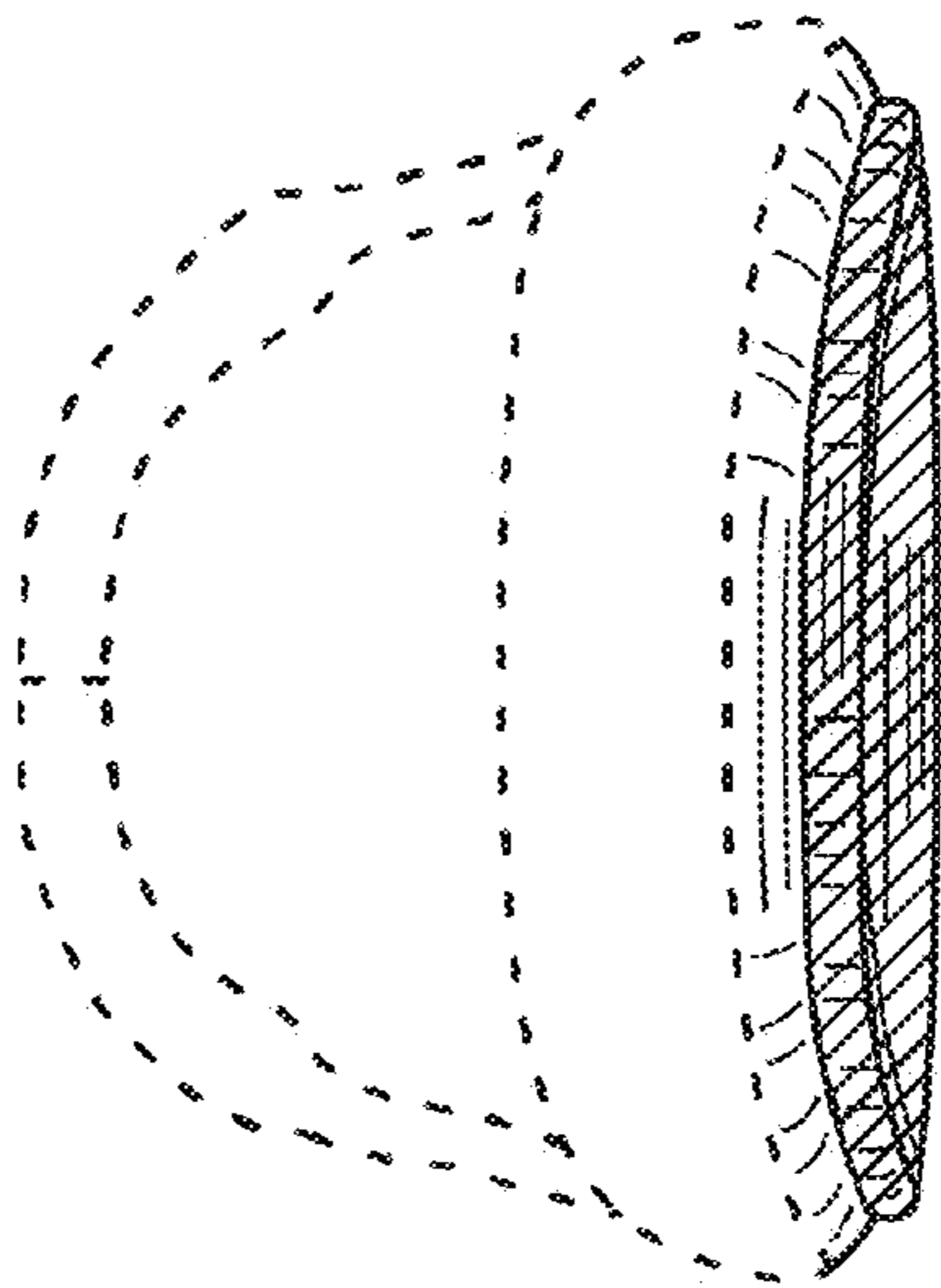

FIG. 6

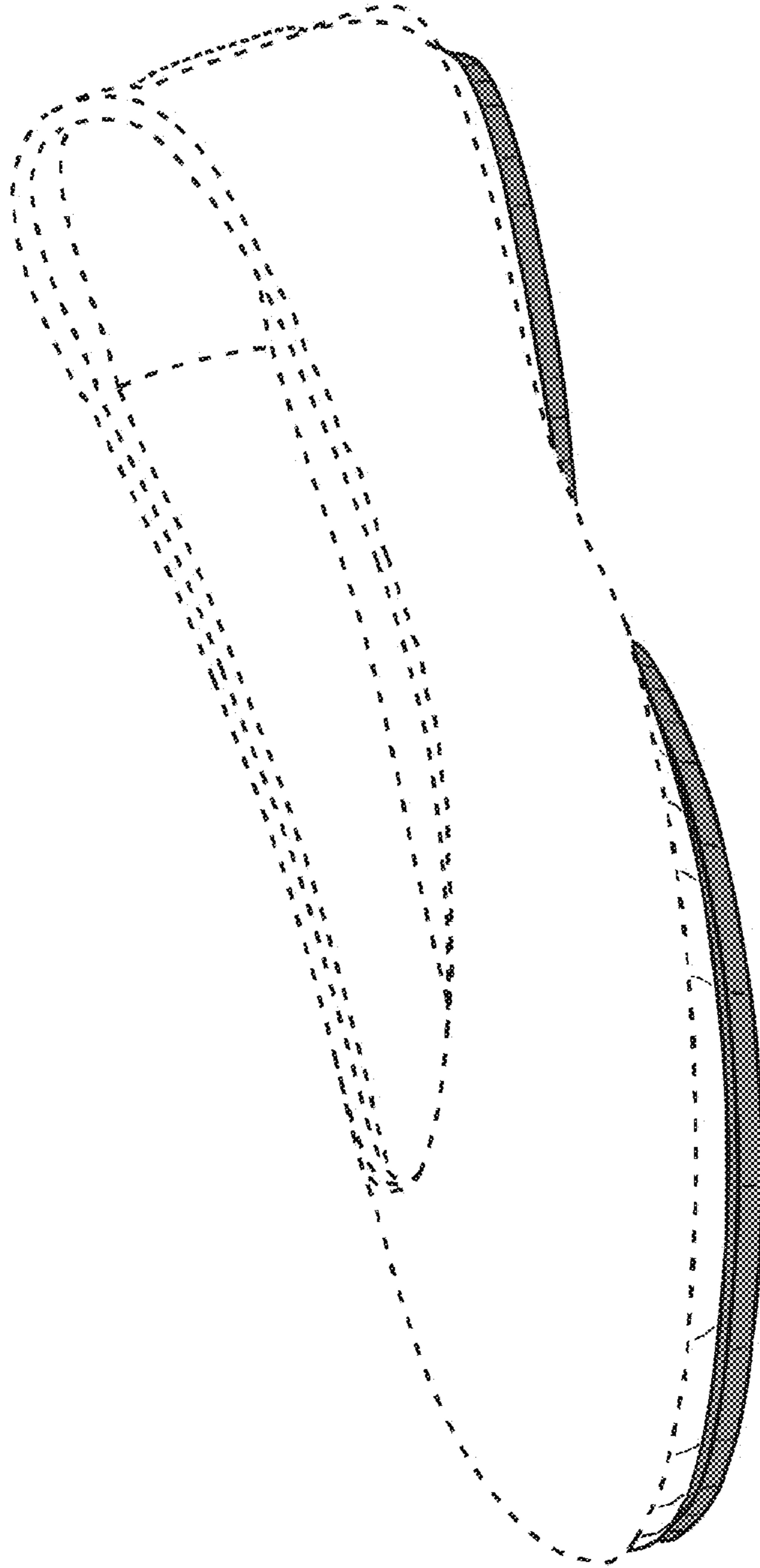

FIG. 8

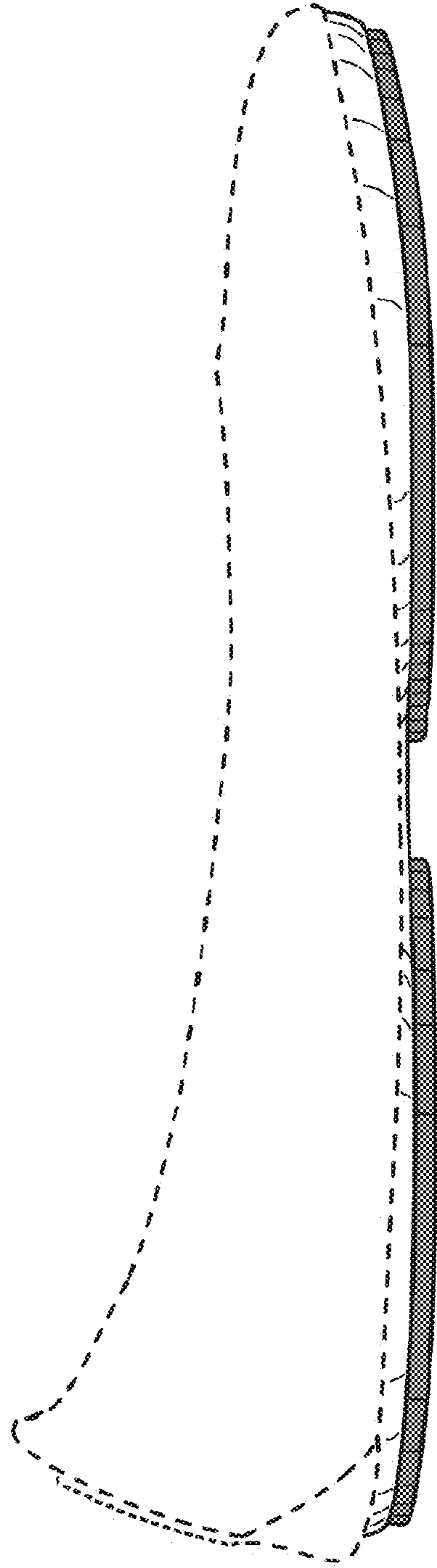

FIG. 9

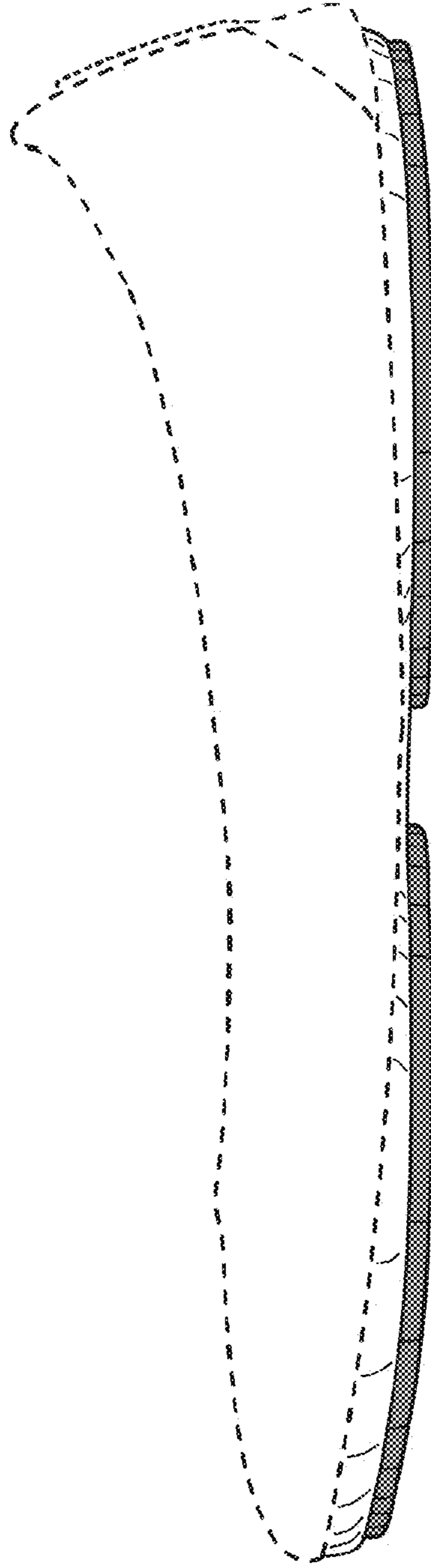

FIG. 10

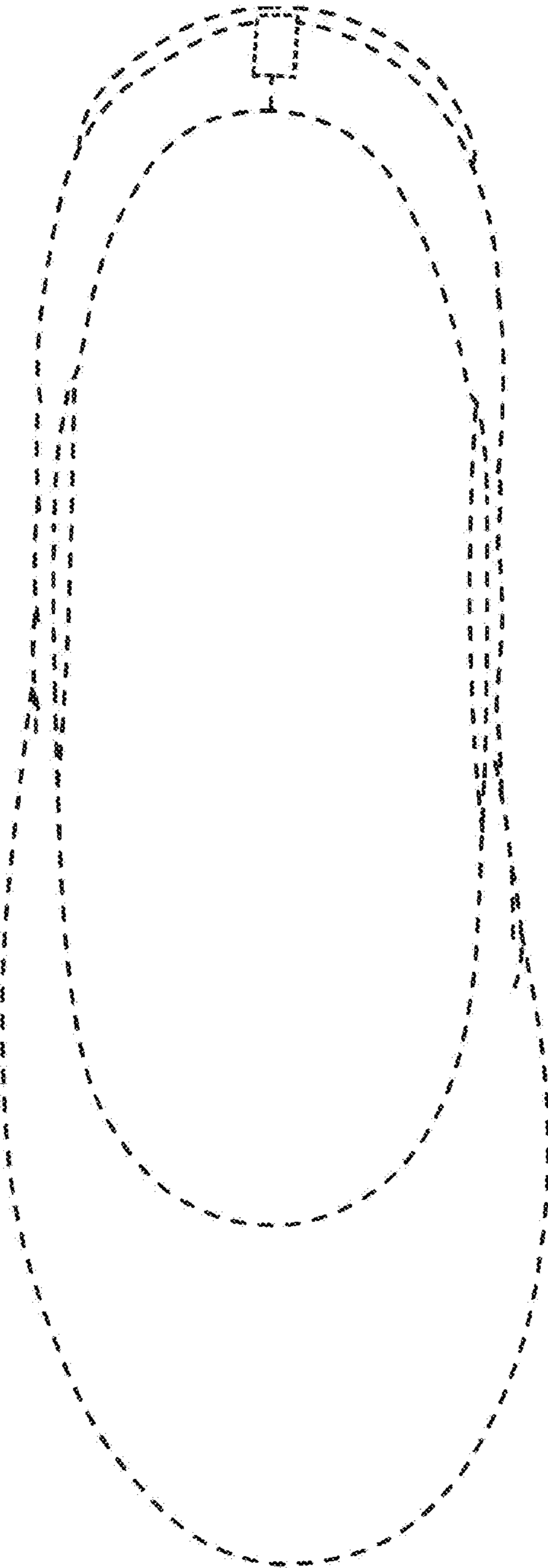

FIG. 11

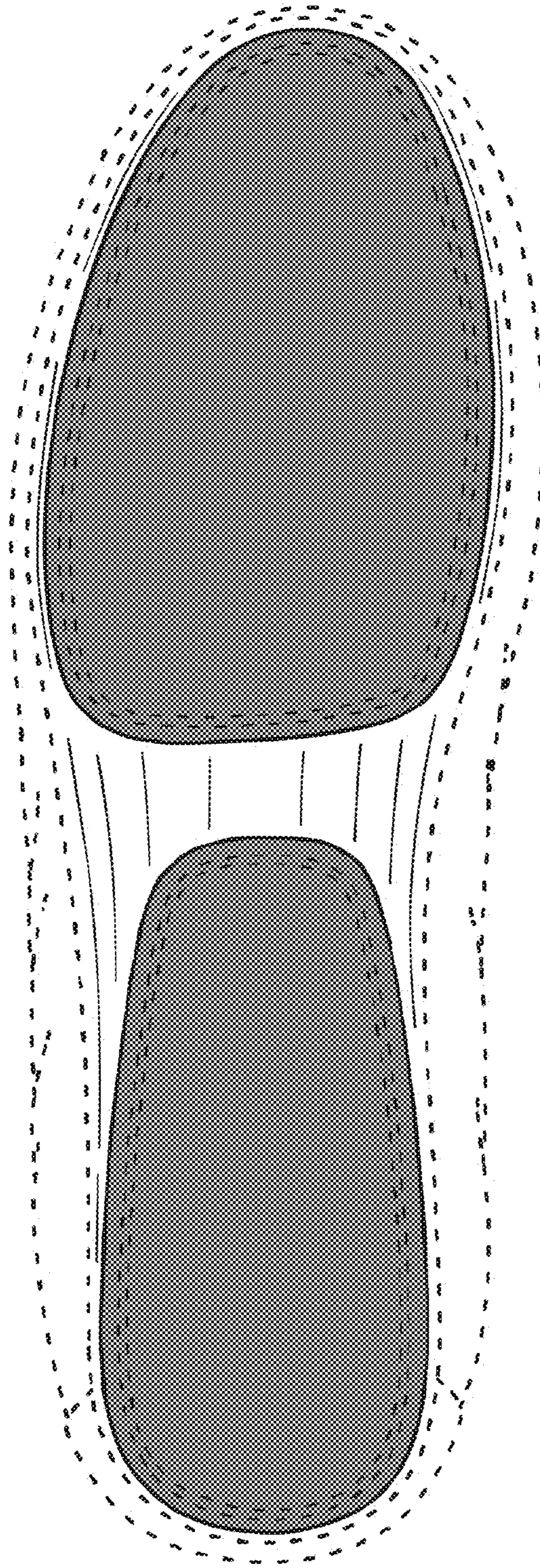

FIG. 12

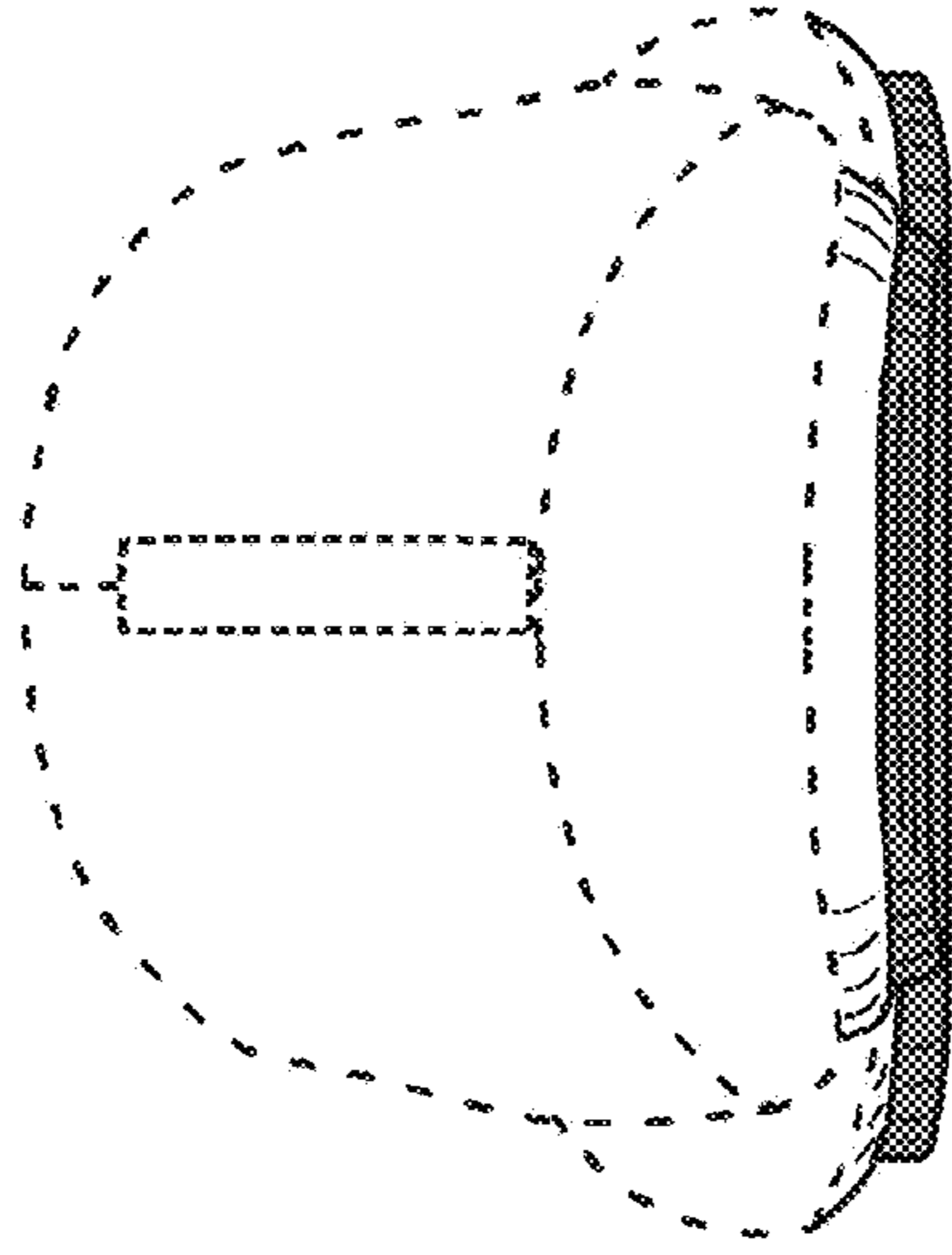

FIG. 14

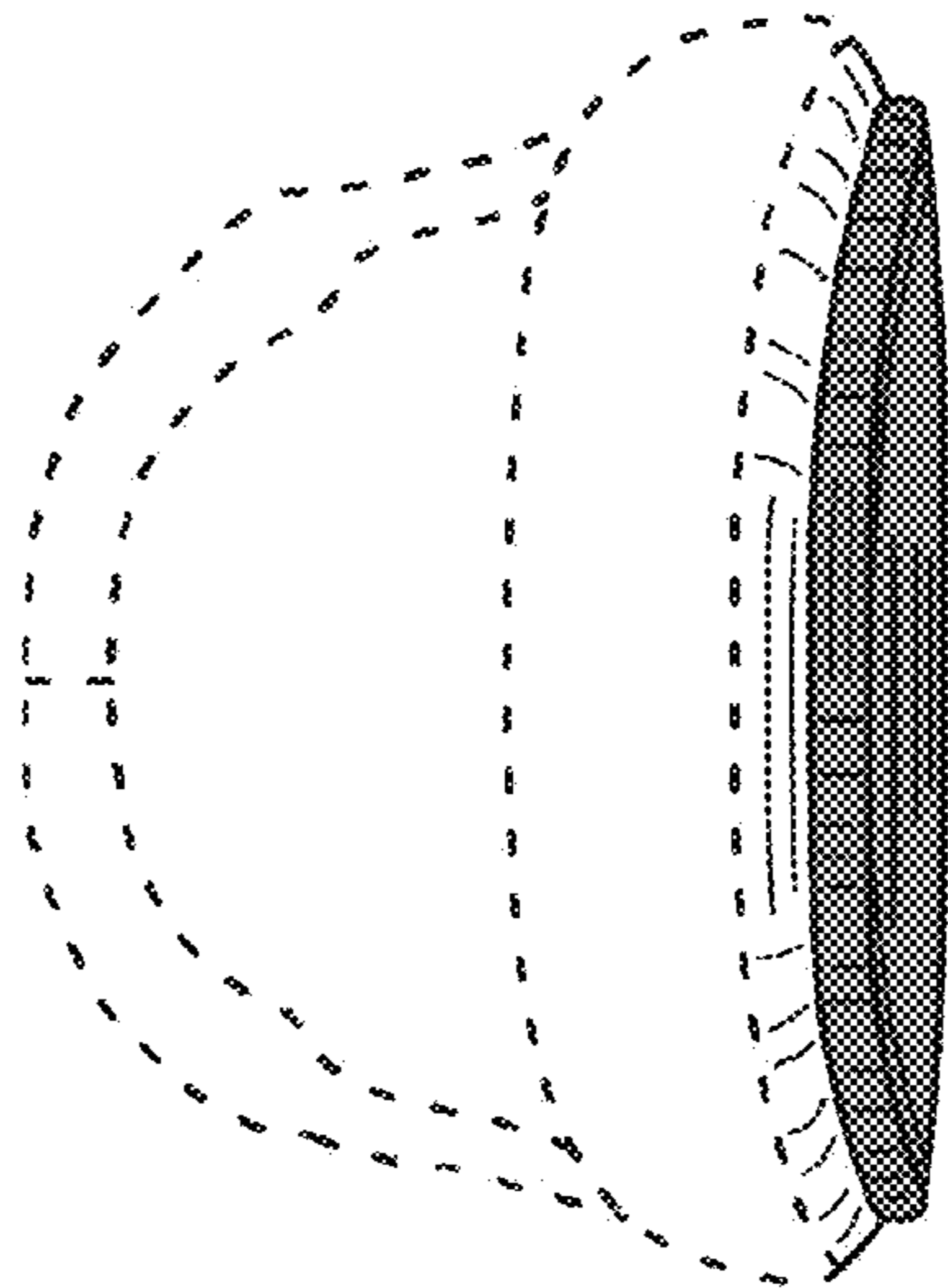

FIG. 13