



US00D943681S

(12) **United States Design Patent** (10) **Patent No.:** **US D943,681 S**
Barajas et al. (45) **Date of Patent:** **** Feb. 15, 2022**

(54) **MODEL VEHICLE BODY ASSEMBLY**

(71) Applicant: **TRAXXAS, L.P.**, McKinney, TX (US)

(72) Inventors: **Jaime Felix Barajas**, Dallas, TX (US);
Kent Poteet, Lucas, TX (US); **Otto Karl Allmendinger**, Rowlett, TX (US);
Skylar Hagler, Anna, TX (US); **Jory Sprowl**, Honey Grove, TX (US)

(73) Assignee: **TRAXXAS LP**, McKinney, TX (US)

(**) Term: **15 Years**

(21) Appl. No.: **29/774,017**

(22) Filed: **Mar. 12, 2021**

(51) **LOC (13) Cl.** **21-01**

(52) **U.S. Cl.**
USPC **D21/548**; D21/533; D21/552

(58) **Field of Classification Search**
USPC D21/433, 552, 562, 548; D12/86, 89, 90,
D12/91, 92, 93, 98

CPC B62D 35/00; B62D 35/007; B62D 37/02;
B62D 23/00; B62D 33/00; B62D 31/00;
B62D 21/00; B62D 29/00; Y02T 10/82

See application file for complete search history.

(56) **References Cited**

U.S. PATENT DOCUMENTS

D190,991 S * 8/1961 Ornas, Jr. D12/98
3,068,038 A * 12/1962 Douglass, Jr. B62D 33/08
296/37.6
3,146,824 A * 9/1964 Veilleux B60J 7/085
160/23.1
3,201,171 A * 8/1965 Wickard B60J 7/062
296/100.15
3,704,039 A * 11/1972 Dean B60J 7/1621
296/100.07
D252,200 S * 6/1979 Brinker 296/107.09
4,188,058 A * 2/1980 Resa B60R 13/01
296/208

(Continued)

FOREIGN PATENT DOCUMENTS

CA 56782 * 8/1986 B60G 7/001
CN 304894048 * 11/2018

(Continued)

OTHER PUBLICATIONS

“1967 Chevy C10 Show Truck Slammed on Coils K5 Blazer Bronco Bagged Slammed,” 1967, topclassiccarsforsale.com, site visited Dec. 20, 2021, URL: <https://topclassiccarsforsale.com/chevrolet/569932-1967-chevy-c10-show-truck-slammed-on-coils-k5-blazer-bronco-bagged-slammed.html> (Year: 1967).*

(Continued)

Primary Examiner — Eric L Goodman

Assistant Examiner — Sarah L Smith

(74) *Attorney, Agent, or Firm* — Daryl R. Wright; Greg Carr

(57) **CLAIM**

We claim the ornamental design for a model vehicle body assembly, as shown and described.

DESCRIPTION

FIG. 1 is an upper, left, front perspective view of a model vehicle body assembly showing our new design;

FIG. 2 is a front elevation view thereof;

FIG. 3 is a rear elevation view thereof;

FIG. 4 is a left side elevation view thereof;

FIG. 5 is a right side elevation view thereof;

FIG. 6 is an upper plan view thereof;

FIG. 7 is a lower plan view thereof; and,

FIG. 8 is an upper, left, rear perspective view of the model vehicle body assembly.

In the drawings, the broken lines illustrate portions of the model vehicle body assembly that form no part of the claimed design.

1 Claim, 6 Drawing Sheets

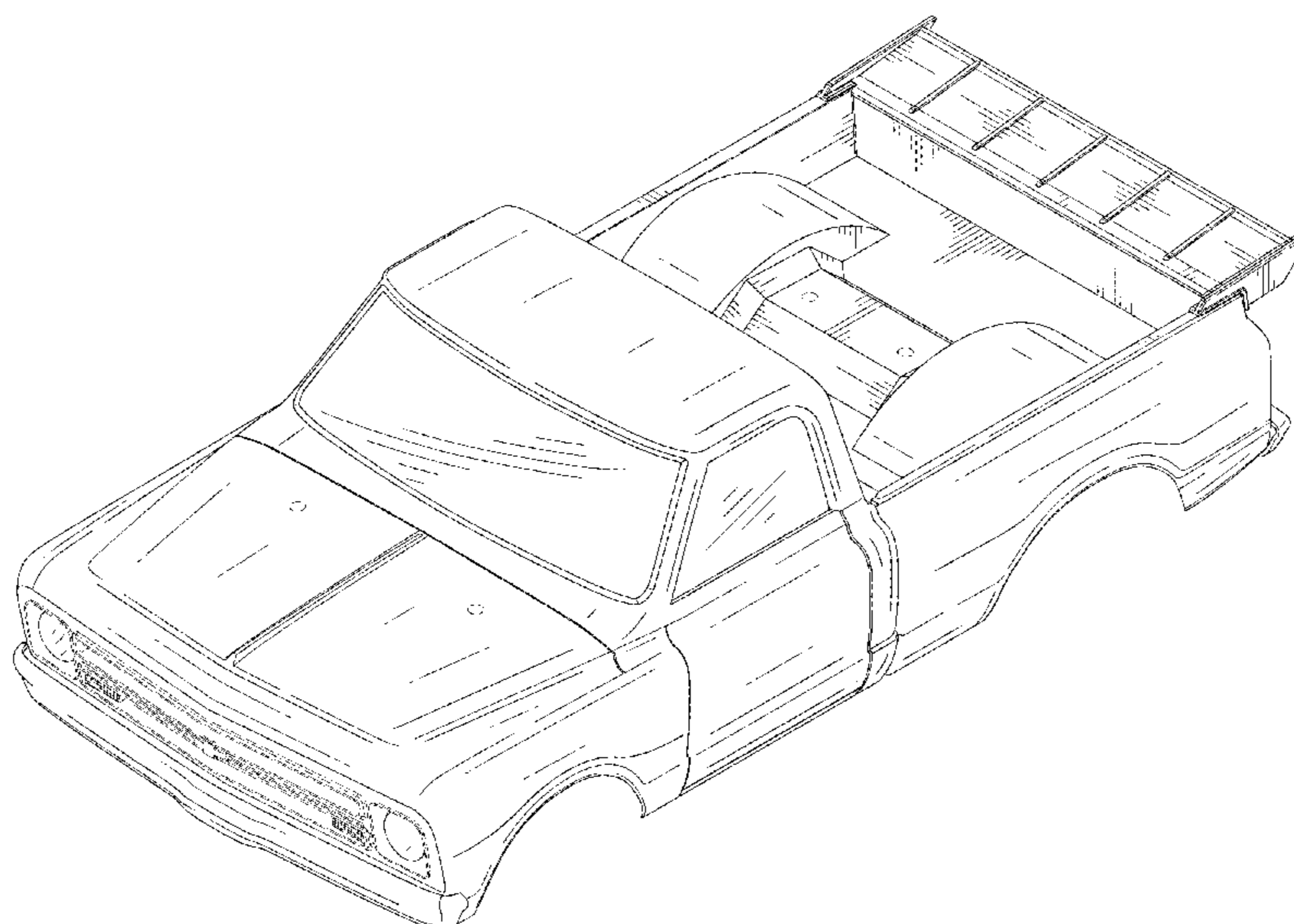

(56)

References Cited

U.S. PATENT DOCUMENTS

D256,901 S * 9/1980 Carr, Jr. D12/14
 4,506,870 A * 3/1985 Penn B62D 33/0273
 296/180.1
 D281,000 S * 10/1985 Kuna B60R 13/01
 D21/559
 D300,522 S * 4/1989 Wegner D12/98
 D312,806 S * 12/1990 Page D12/98
 D313,379 S * 1/1991 Machida D12/98
 5,615,922 A * 4/1997 Blanchard B60R 9/02
 224/404
 6,520,564 B1 * 2/2003 Liang B62D 35/007
 296/180.5
 D496,409 S * 9/2004 Tilbor D21/559
 D603,295 S * 11/2009 Honeycutt D12/86
 D790,402 S * 6/2017 Perini B62D 33/08
 D12/92
 D879,209 S * 3/2020 Ewing B62D 35/007
 D21/433
 D879,212 S * 3/2020 Barajas D21/562
 10,661,843 B1 * 5/2020 Nieves B62D 33/0276
 2009/0195016 A1 * 8/2009 Schwan B62D 35/007
 296/180.3

2013/0221701 A1* 8/2013 De Luca B62D 37/02
 296/180.5
 2019/0256157 A1* 8/2019 Hinterbuchinger .. B62D 35/007
 2020/0070903 A1* 3/2020 Woelfle B62D 35/007

FOREIGN PATENT DOCUMENTS

KR 300908105.0000 * 5/2017
 WO WO-2021046302 A1 * 3/2021 B60G 7/001

OTHER PUBLICATIONS

Tim Bernsau (photographer), Jorge Nunez (author), "Is This The Most Powerful 1967 Chevy C10?" May 27, 2017, motortrend.com, site visited Dec. 21, 2021, URL: <https://www.motortrend.com/features/powerful-1967-chevy-c10/> (Year: 2017).*
 "TMI Products," Jul. 30, 2019, facebook.com, site visited Dec. 14, 2021, URL: <https://www.facebook.com/TMIproducts/photos/a.217425150700/10157919220855701/> (Year: 2019).*
 "TMI Products," May 5, 2019 (1967 C10), facebook.com, site visited Dec. 14, 2021, URL: <https://www.facebook.com/TMIproducts/photos/a.217425150700/10157533970560701/> (Year: 2019).*
 "Jconcepts," Aug. 31, 2019, instagram.com, site visited Dec. 20, 2021, URL: <https://www.instagram.com/p/B119ULnhy4C/> (Year: 2019).*

* cited by examiner

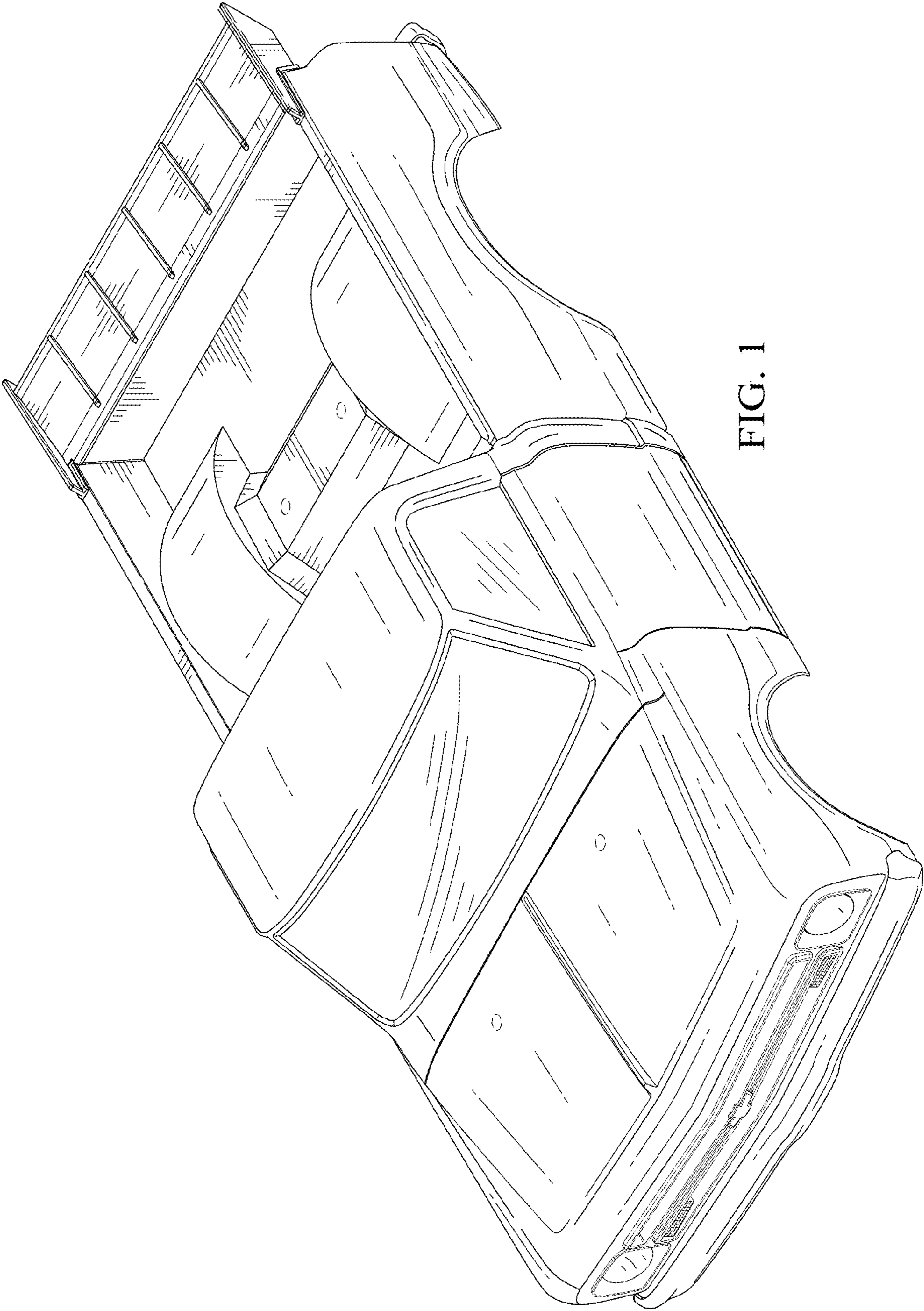

FIG. 1

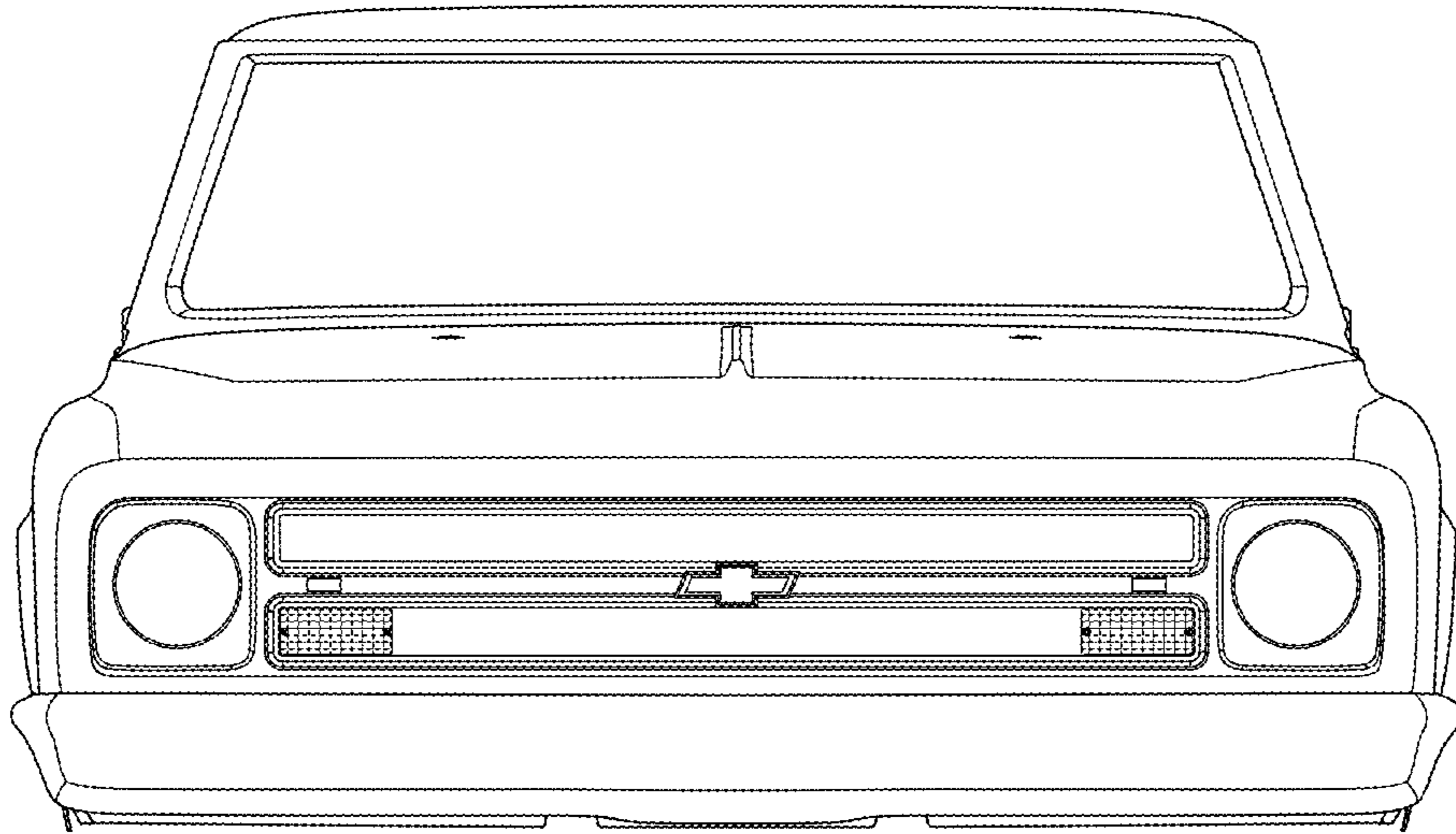

FIG. 2

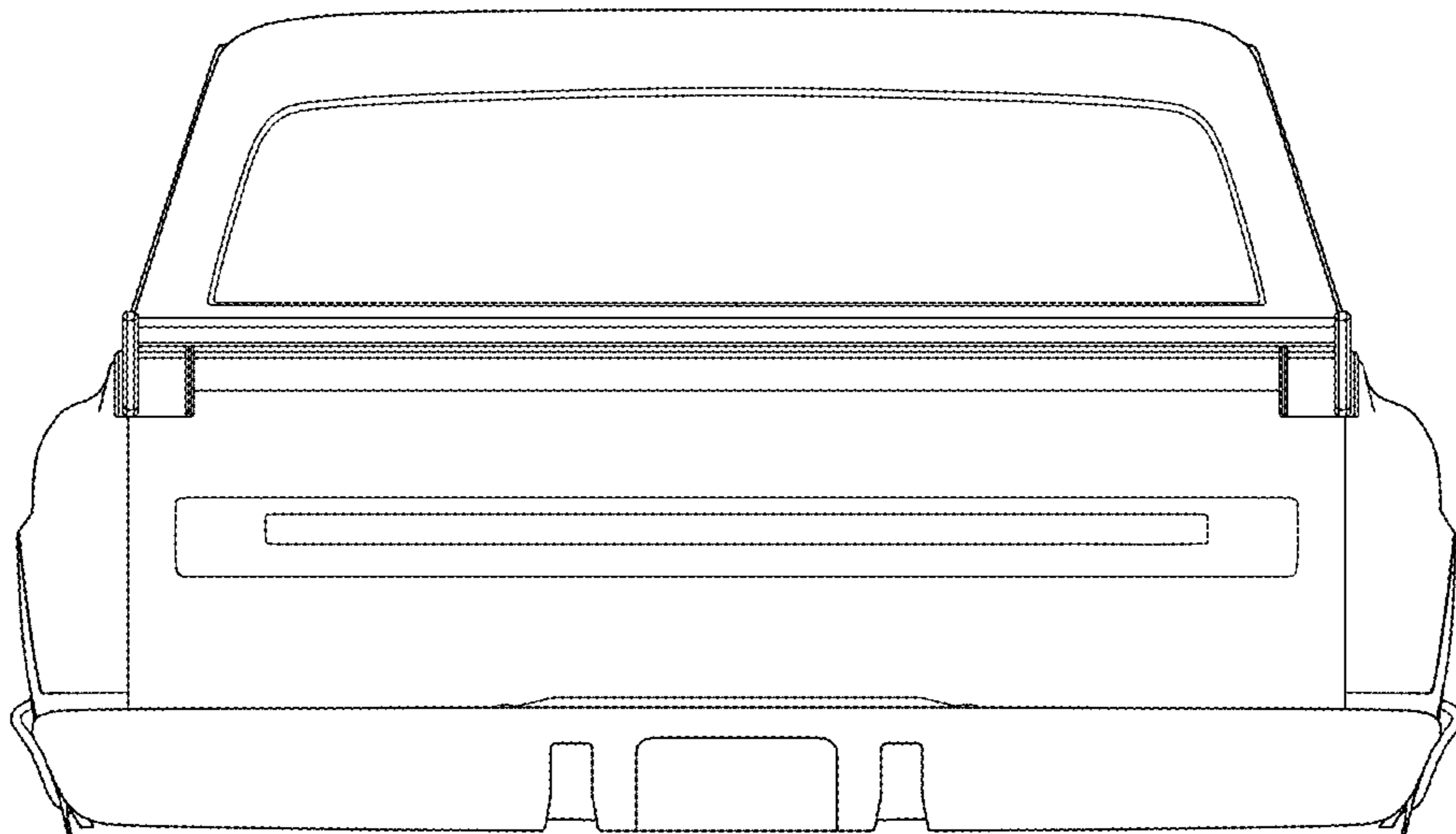

FIG. 3

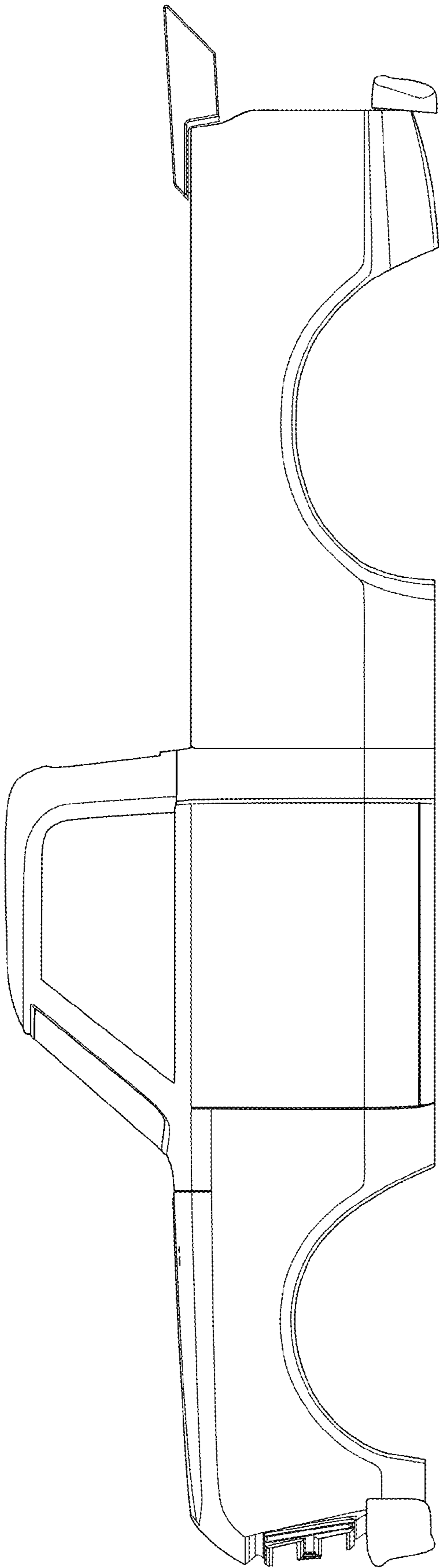

FIG. 4

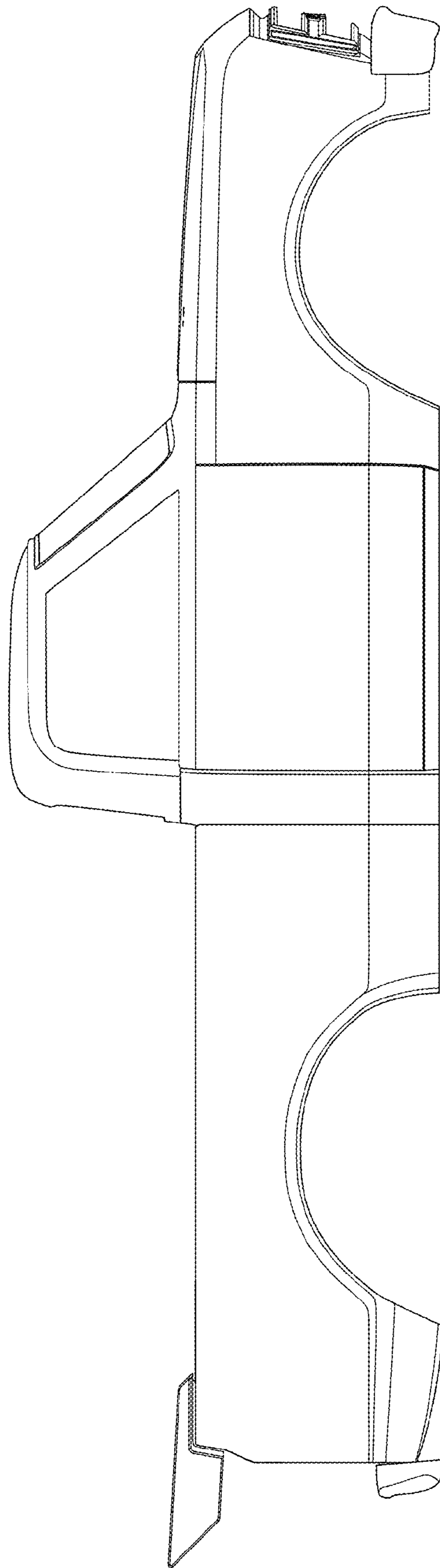

FIG. 5

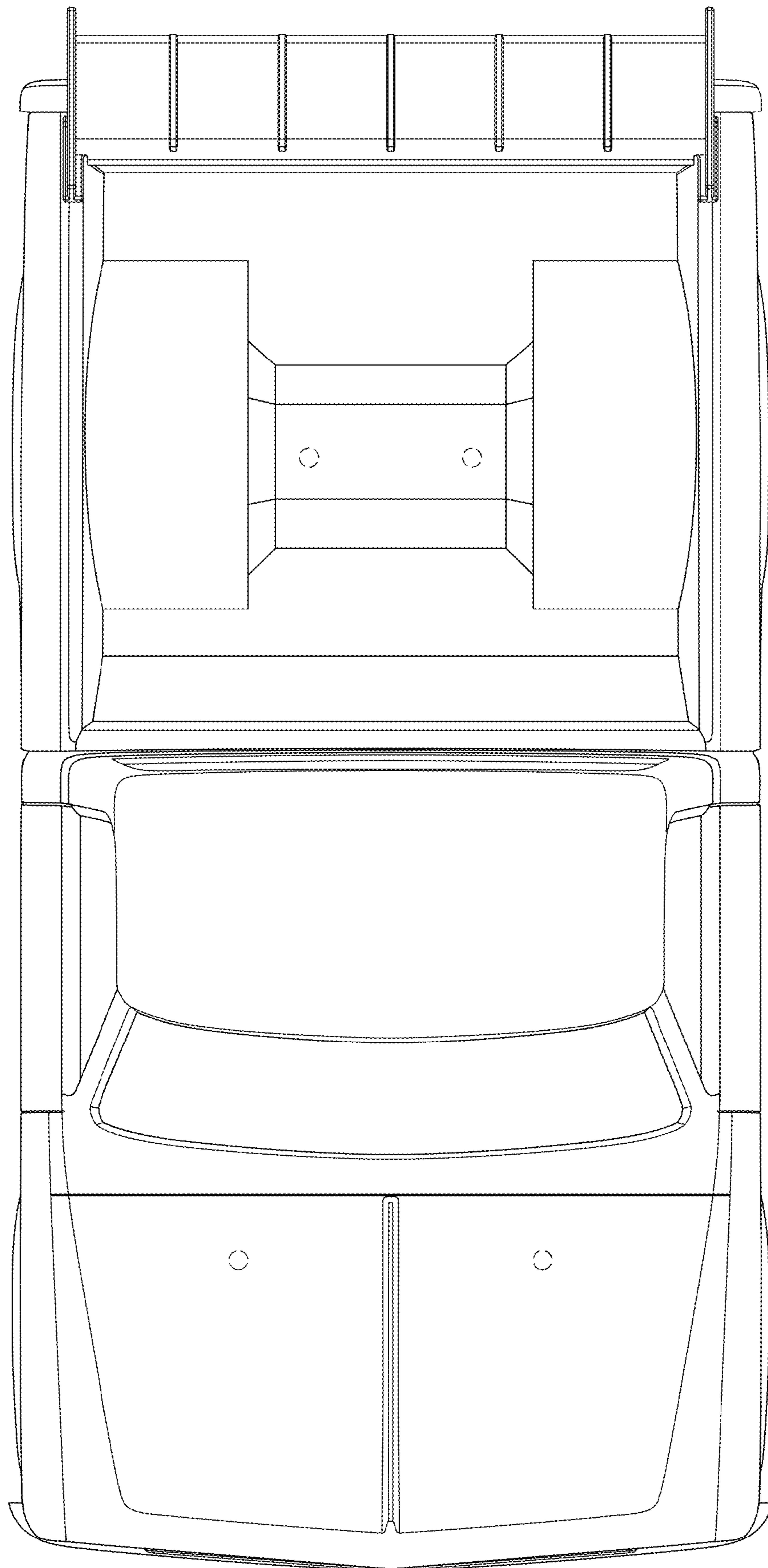

FIG. 6

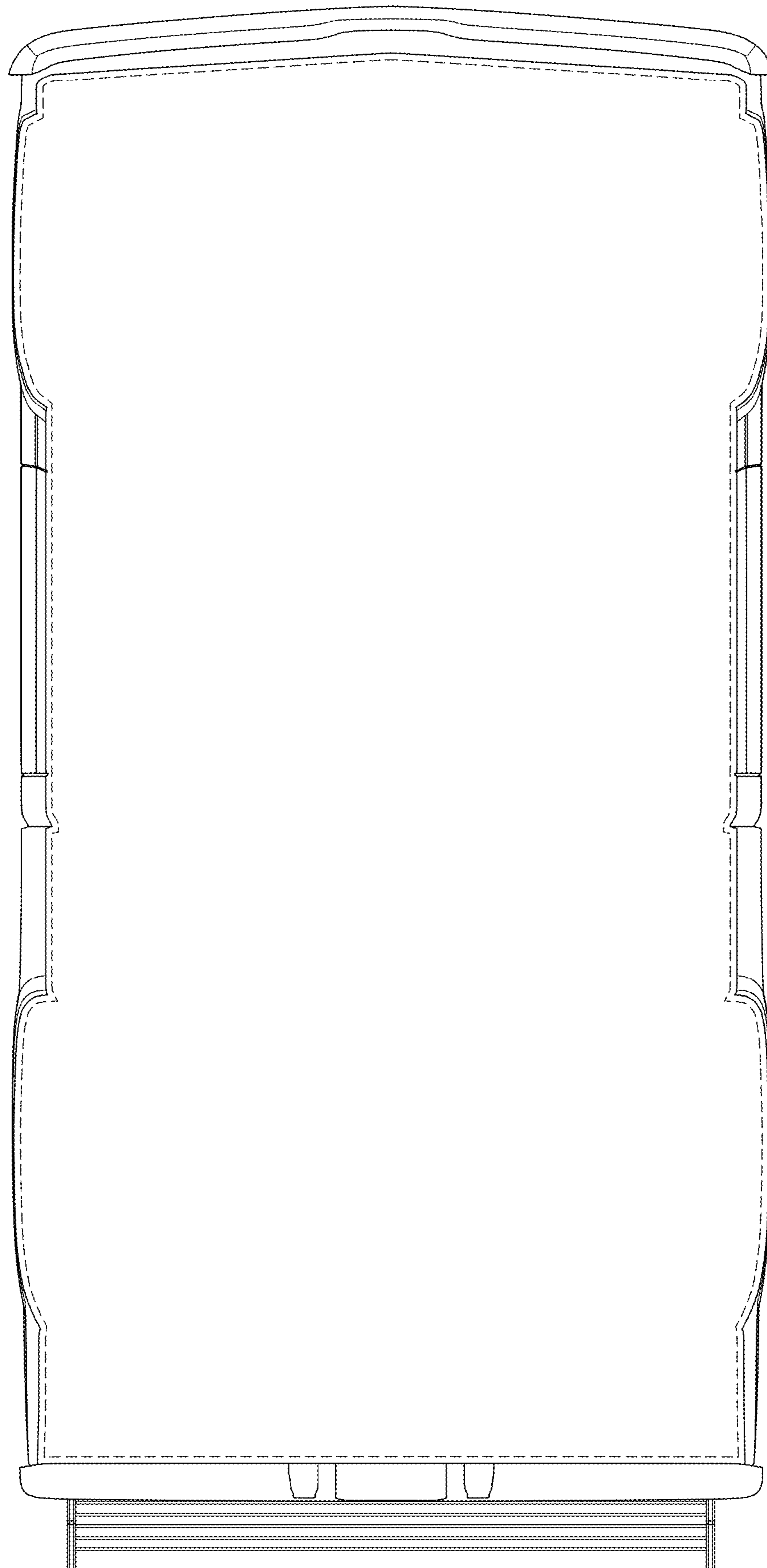

FIG. 7

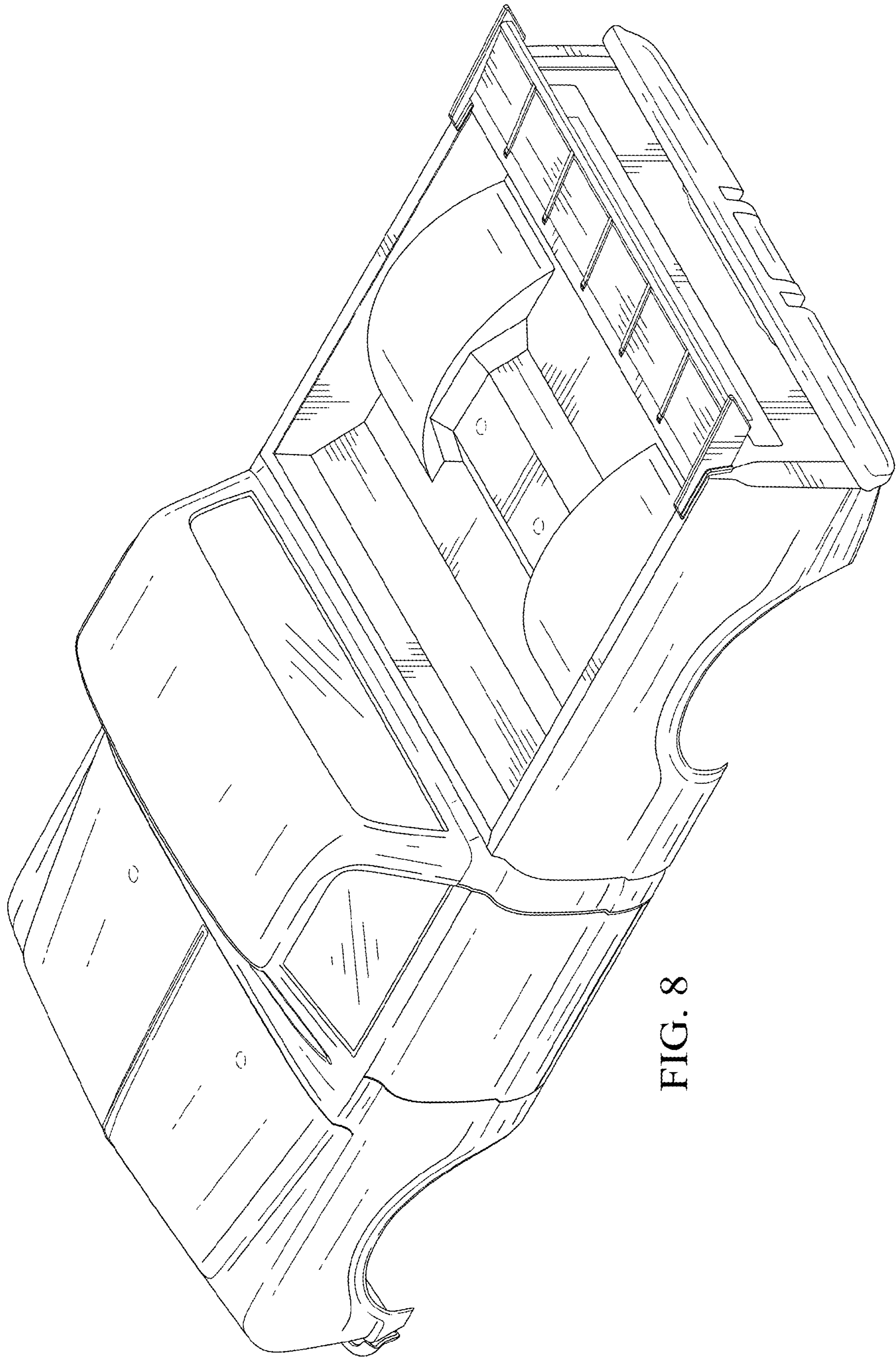

FIG. 8