



US00D943678S

(12) **United States Design Patent**
Yao et al.

(10) **Patent No.:** **US D943,678 S**
(45) **Date of Patent:** **** Feb. 15, 2022**

(54) **MOTORIZED SCOOTER**

(71) Applicant: **ZHEJIANG TAOTAO VEHICLES CO., LTD**, Lishui (CN)

(72) Inventors: **Guangqing Yao**, Yongkang (CN);
Yuqiang Fu, Henan Province (CN);
Hongxia Zhu, Henan Province (CN)

(**) Term: **15 Years**

(21) Appl. No.: **29/745,607**

(22) Filed: **Aug. 7, 2020**

(30) **Foreign Application Priority Data**

Jun. 11, 2020 (CN) 202030296701.0

(51) **LOC (13) Cl.** **21-01**

(52) **U.S. Cl.**
USPC **D21/423**

(58) **Field of Classification Search**

USPC D21/419, 421, 423, 760, 765, 771;
D12/1, 8, 107, 110, 112-114

CPC . B62K 3/002; B62K 9/00; B62K 9/02; B62K
2202/00; B62K 13/00; B62K 11/00;
B62K 11/02; B62K 11/06; B62K 11/10;
B62K 15/00; B62K 17/00; B60Y
2200/126; H04W 4/40

See application file for complete search history.

(56) **References Cited**

U.S. PATENT DOCUMENTS

6,158,751 A * 12/2000 Wu B62K 3/002
280/87.041

D492,367 S * 6/2004 Dennis B60K 17/26
D21/423

D811,489 S * 2/2018 Hadley D21/423
(Continued)

FOREIGN PATENT DOCUMENTS

CN 108357611 A * 8/2018 B62H 5/08
EM 008261952-0003 * 11/2020

(Continued)

OTHER PUBLICATIONS

Dan Keshet, "Lockless and Flockless: The State of Austin's Dockless Vehicle Pilot Program," Jun. 8, 2018, austin.towers.net, site visited Aug. 23, 2021, URL: <https://austin.towers.net/lockless-and-flockless-the-state-of-austins-dockless-vehicle-pilot-program/> (Year: 2018).*

(Continued)

Primary Examiner — Eric L Goodman

Assistant Examiner — Sarah L Smith

(57) **CLAIM**

The ornamental design for a motorized scooter, as shown and described.

DESCRIPTION

FIG. 1 is a front and top perspective view of a motorized scooter, showing our new design;

FIG. 2 is a rear and bottom perspective view thereof;

FIG. 3 is a front elevational view thereof;

FIG. 4 is a rear elevational view thereof;

FIG. 5 is a left side elevational view thereof;

FIG. 6 is a right side elevational view thereof;

FIG. 7 is a top plan view thereof;

FIG. 8 is a bottom plan view thereof;

FIG. 9 is an enlarged view of a handle in FIG. 1;

FIG. 10 is an enlarged view of a connector in FIG. 1;

FIG. 11 is an enlarged view of a bracket spindle in FIGS. 1; and,

FIG. 12 is an enlarged view of a front wheel in FIG. 2.

The dashed broken lines in the figures illustrate portions of the article that form no part of the claimed design. The dash dot dash lines in FIGS. 1-2 and 9-12 are for the purpose of depicting the boundary lines of the enlarged view and form no part of the claim.

1 Claim, 12 Drawing Sheets

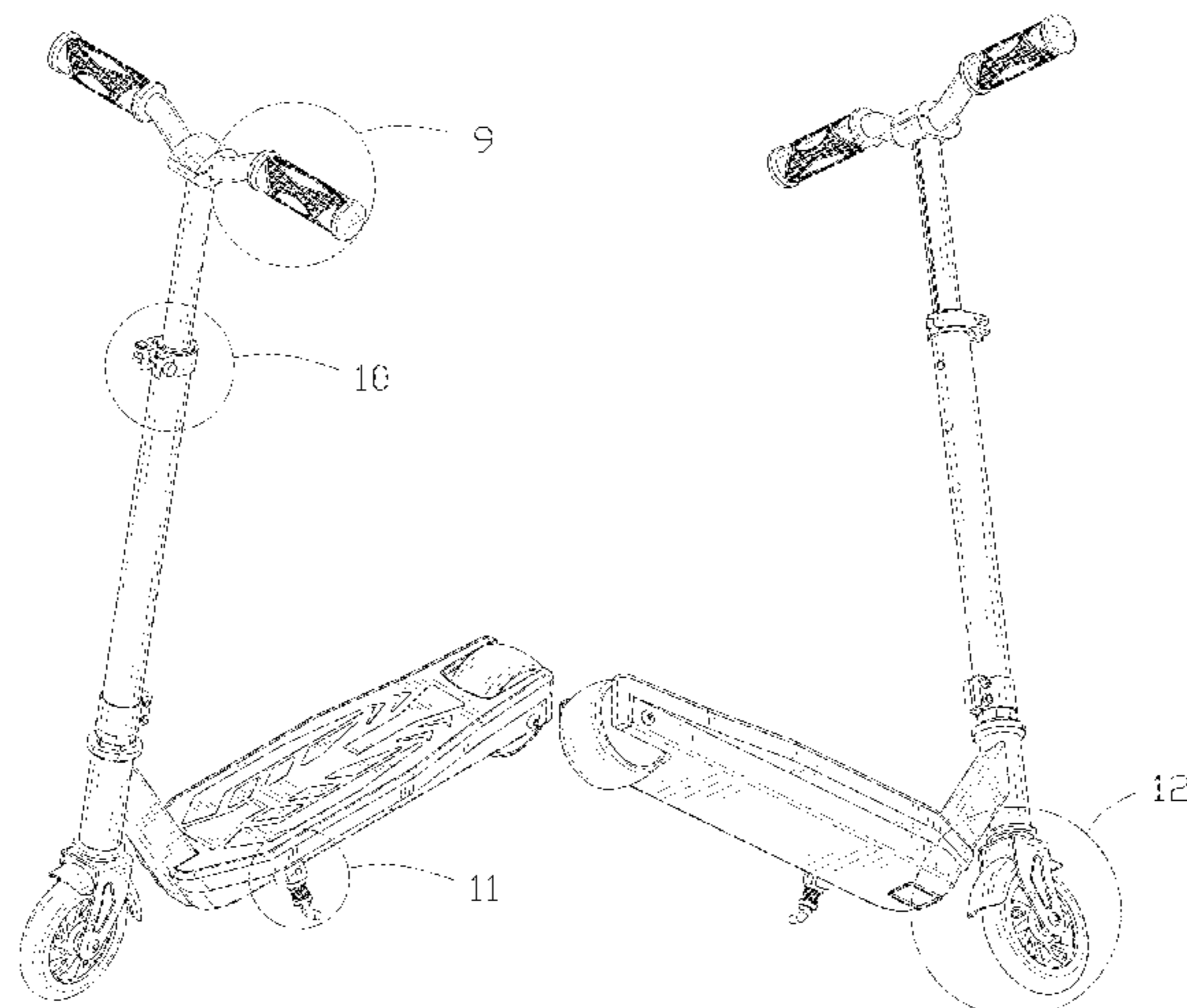

(56)

References Cited

U.S. PATENT DOCUMENTS

10,189,533 B2 * 1/2019 Lovley, II B62K 3/002
D849,153 S * 5/2019 Zhang B62L 1/04
D21/423
D918,305 S * 5/2021 Fan D21/423
2004/0145141 A1 * 7/2004 Dennis B62K 21/18
280/87.05
2013/0257003 A1 * 10/2013 Chen B62K 21/12
280/87.041
2014/0091544 A1 * 4/2014 Chung B62K 3/002
280/87.041
2014/0196968 A1 * 7/2014 Bieler B62M 6/65
180/181
2019/0263468 A1 * 8/2019 Huang B60K 17/26
2021/0078661 A1 * 3/2021 Chen B62L 1/04

FOREIGN PATENT DOCUMENTS

WO WO-2012163789 A1 * 12/2012 B62H 5/08
WO WO-2015161365 A1 * 10/2015 B62H 5/02

OTHER PUBLICATIONS

Nick Statt, "A Cyclone of Scooters Has Descended on Austin for SXSW, for Better or Worse," Mar. 11, 2019, [theverge.com](https://www.theverge.com), site visited Aug. 23, 2021, URL: <https://www.theverge.com/2019/3/11/18260154/austin-scooters-bird-lime-uber-jump-sxsw-2019-dangerous-future-urban-transit> (Year: 2019).*

Toll, Micah, "The ridiculously fun WideWheel electric scooter is back with upgraded brakes," Oct. 30, 2019, electrek.co, site visited Aug. 23, 2021, URL: <https://electrek.co/2019/10/30/widewheel-electric-scooter-brakes-fluidfreeride/> (Year: 2019).*

* cited by examiner

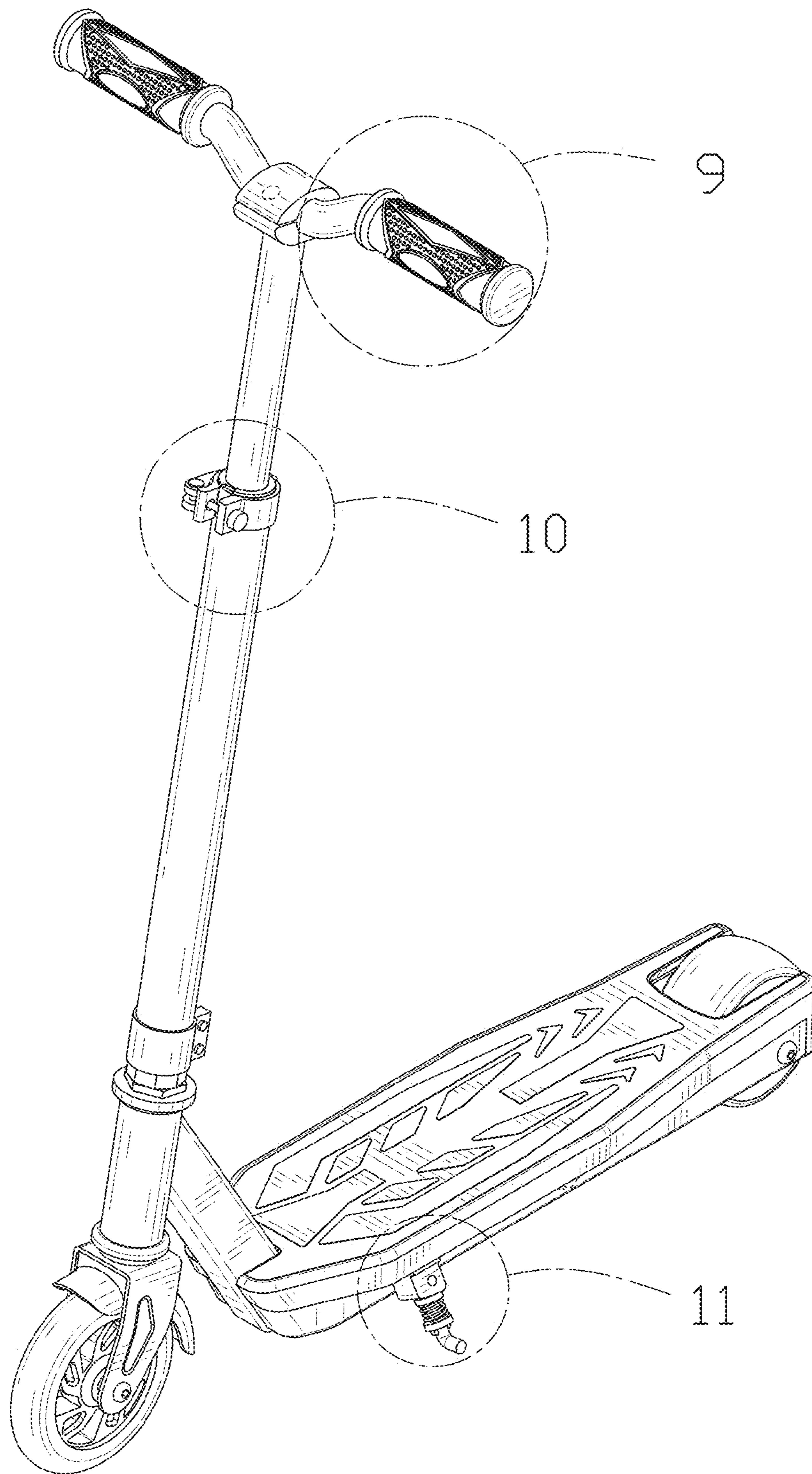

FIG. 1

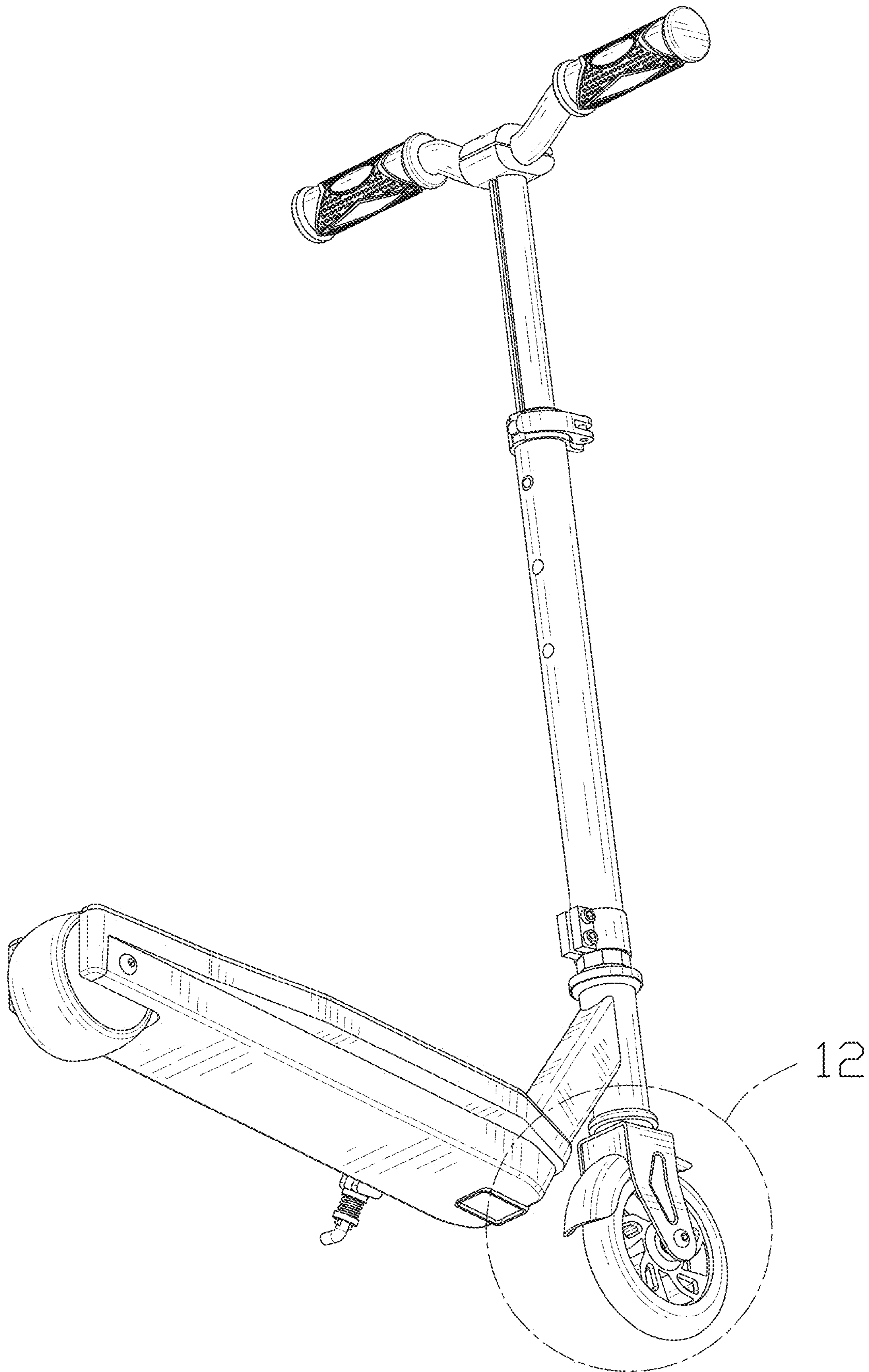

FIG. 2

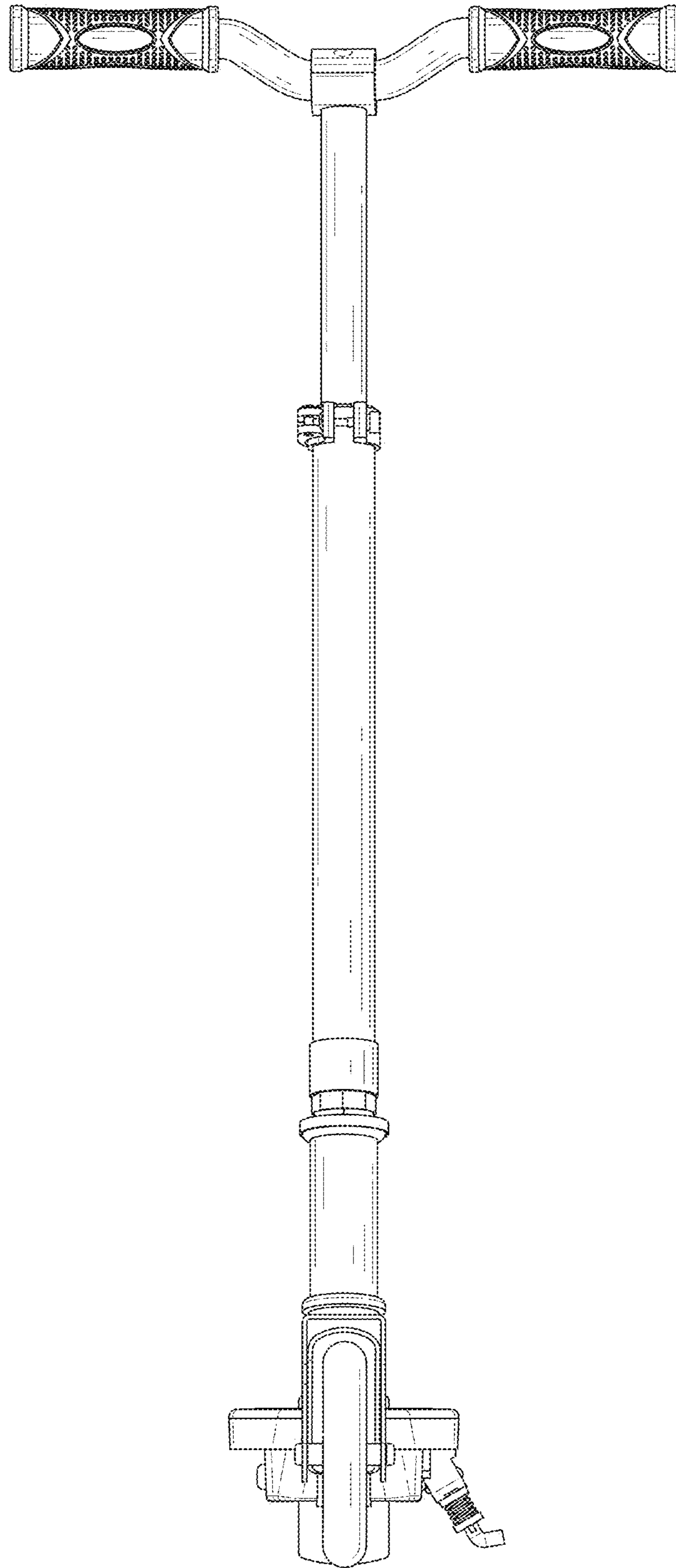

FIG. 3

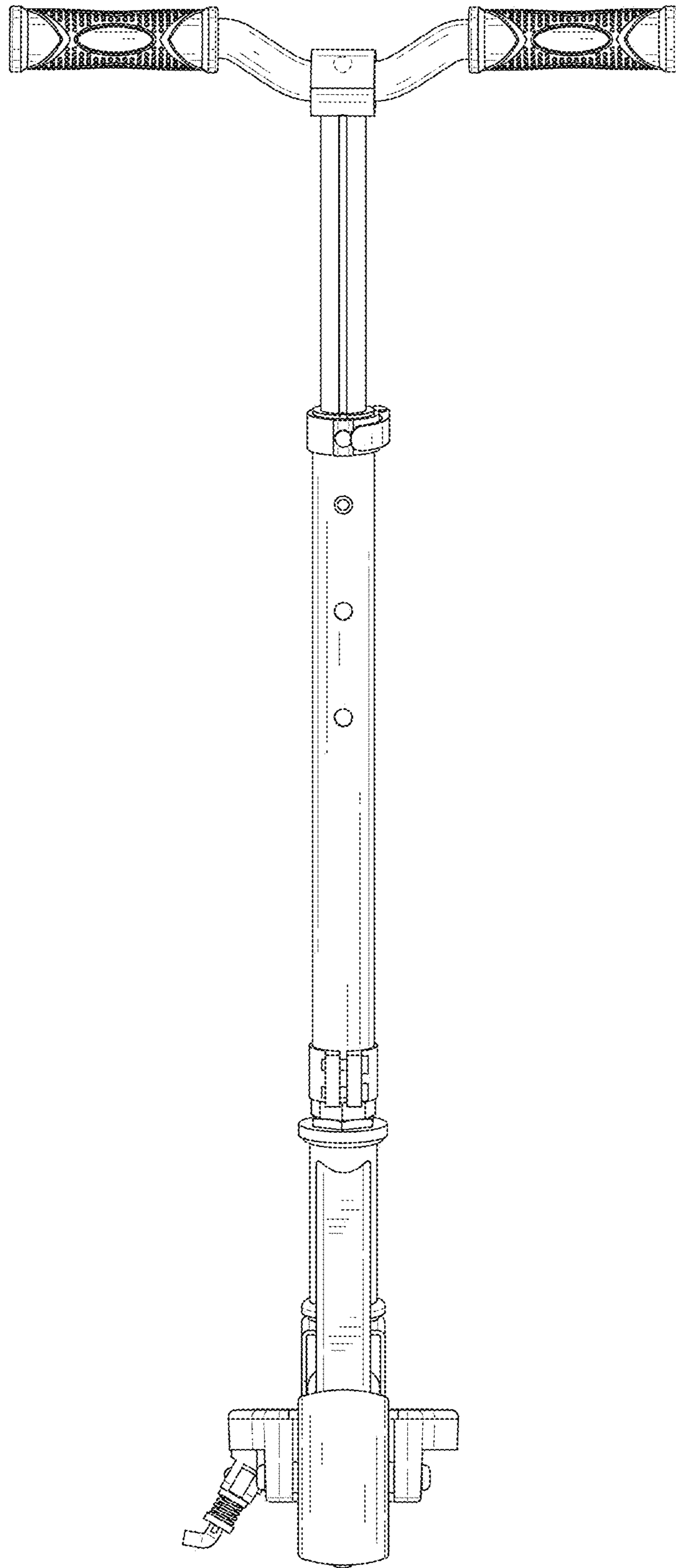

FIG. 4

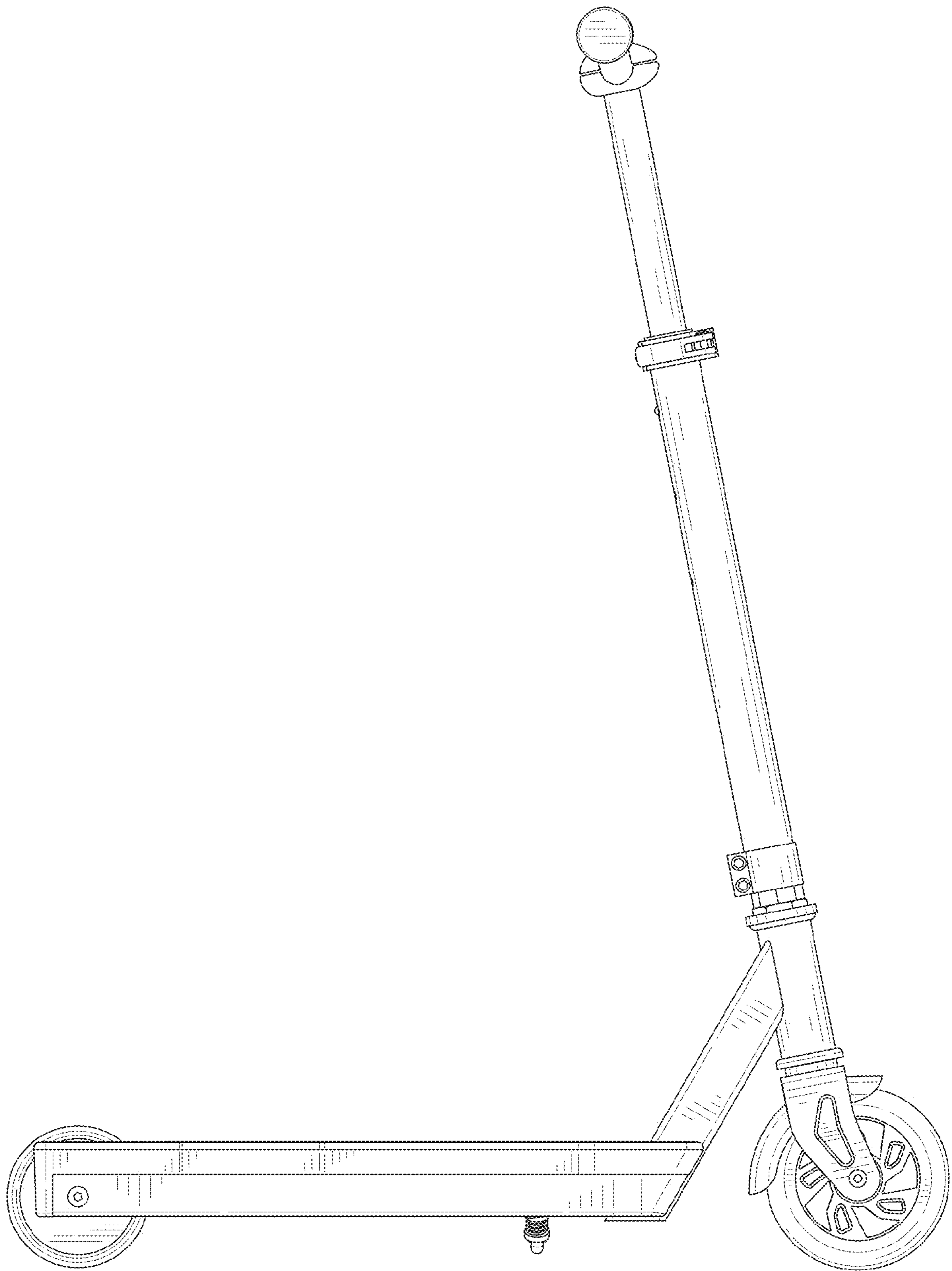

FIG. 5

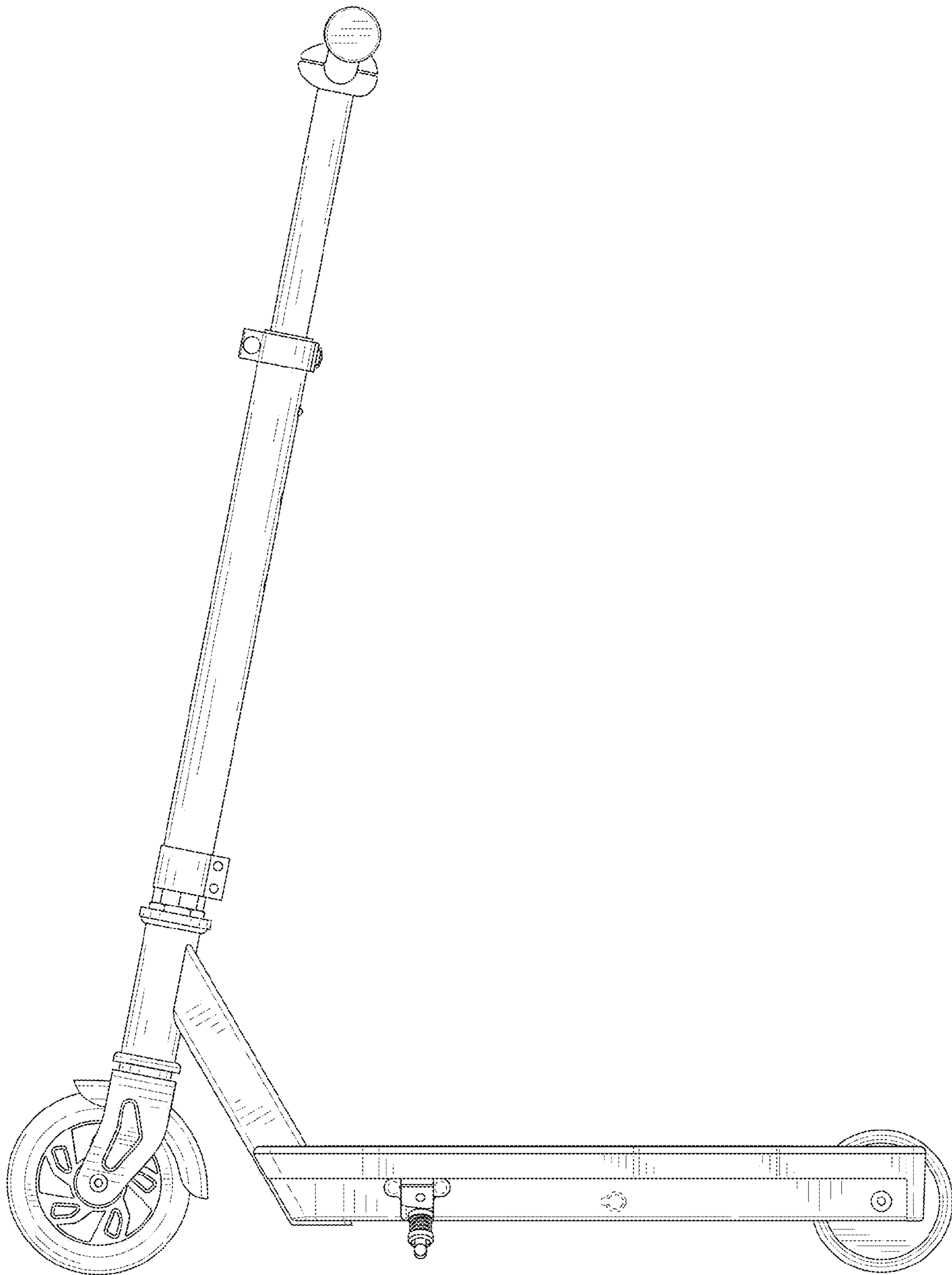

FIG. 6

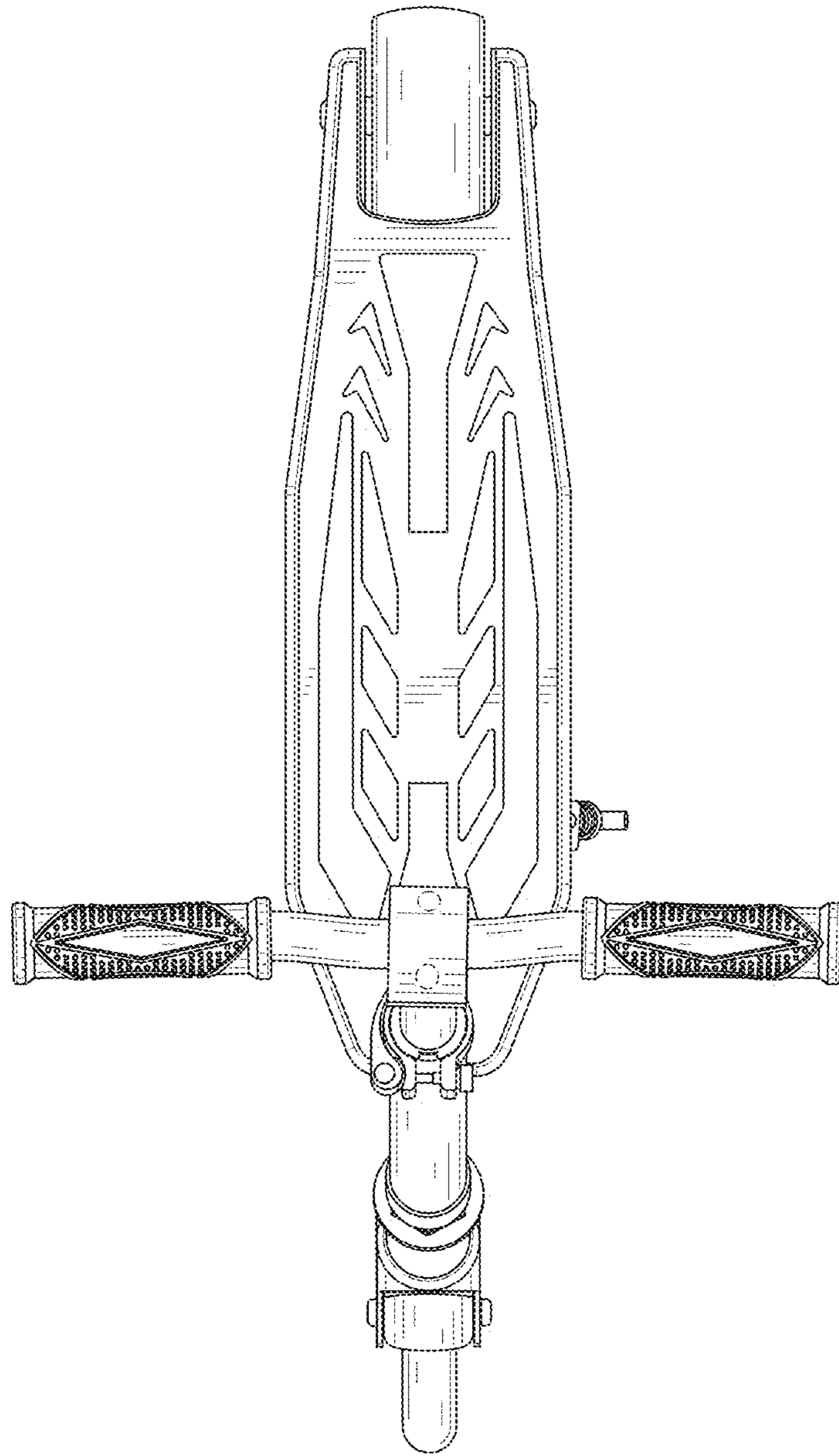

FIG. 7

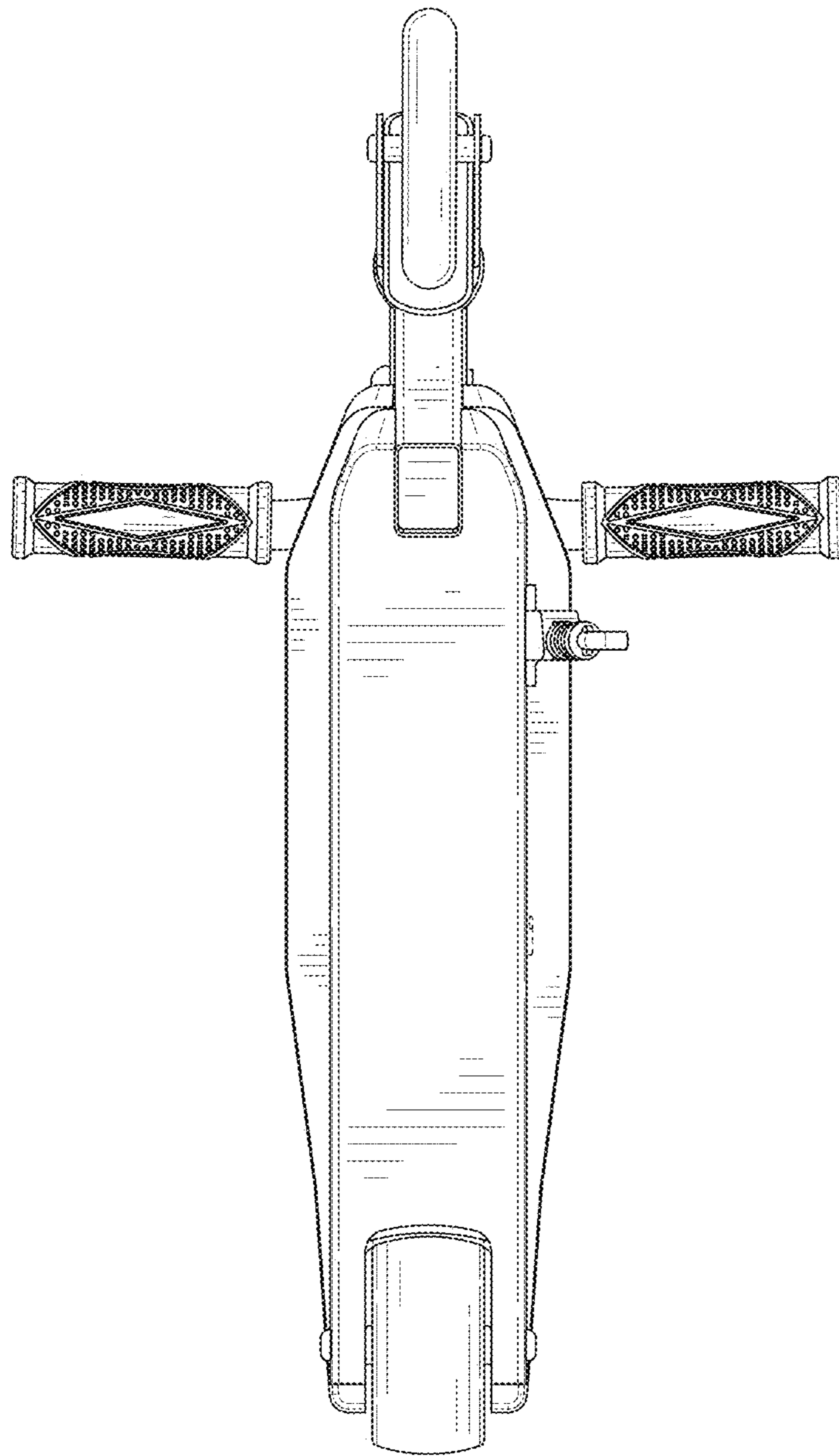

FIG. 8

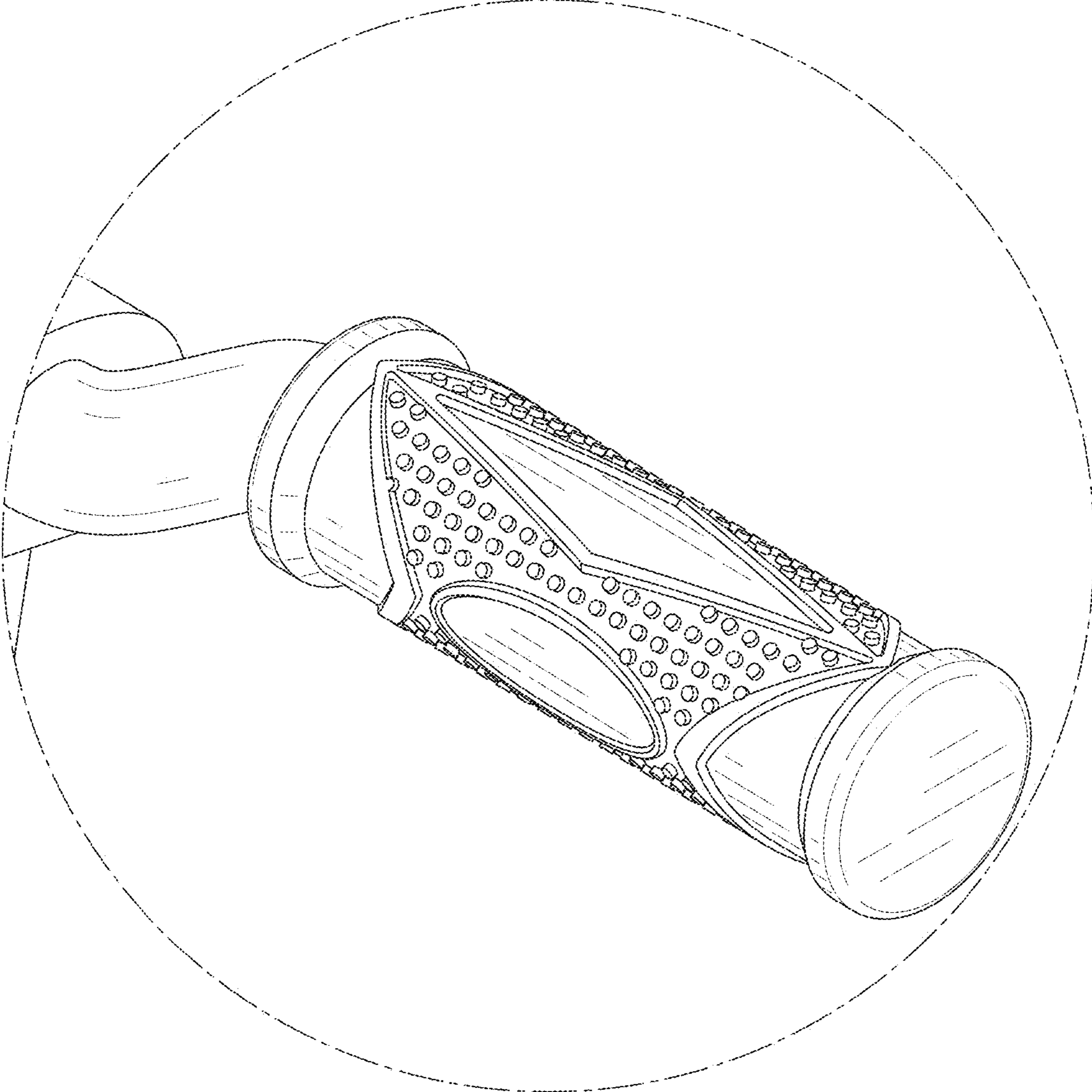

FIG. 9

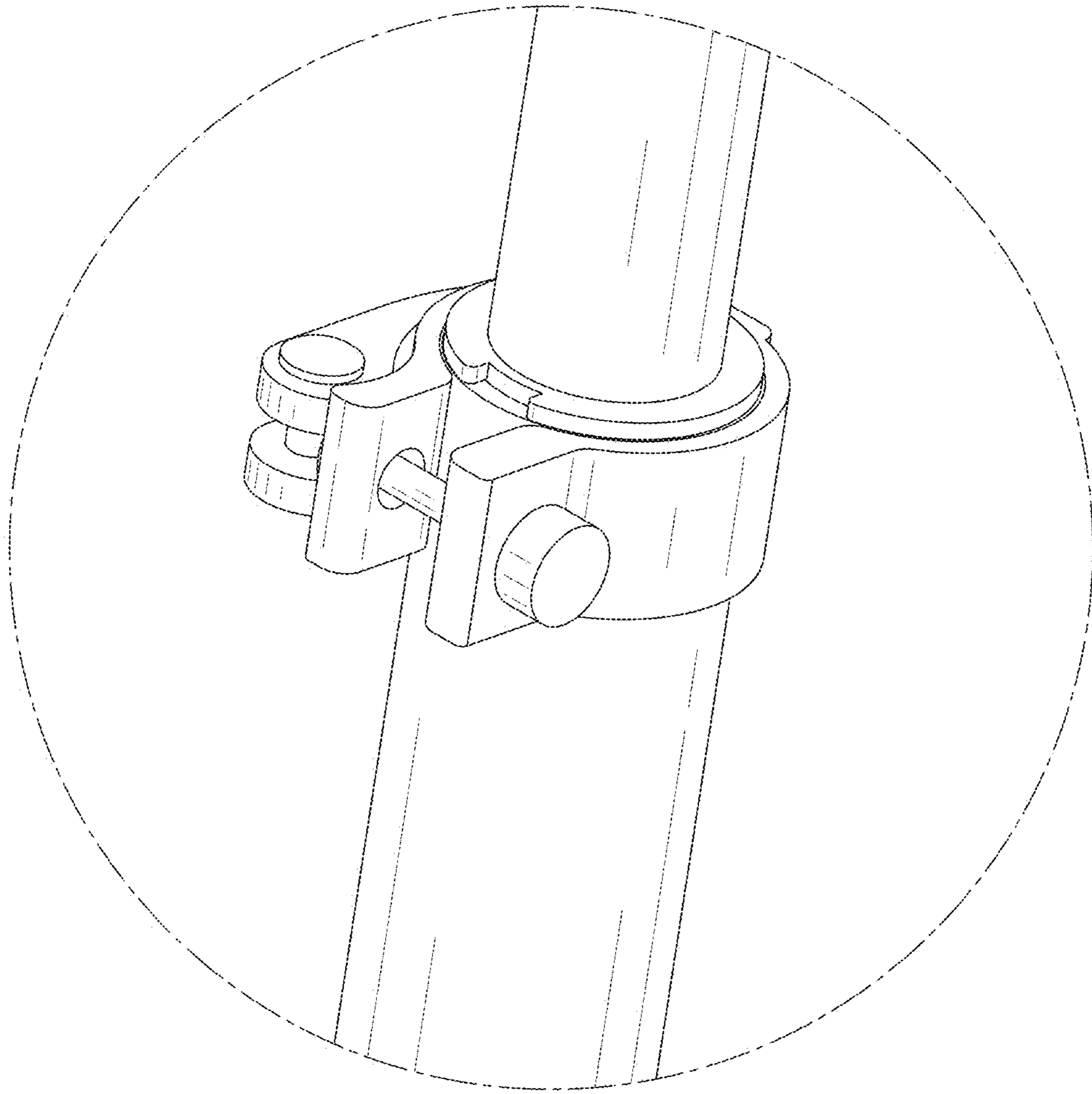

FIG. 10

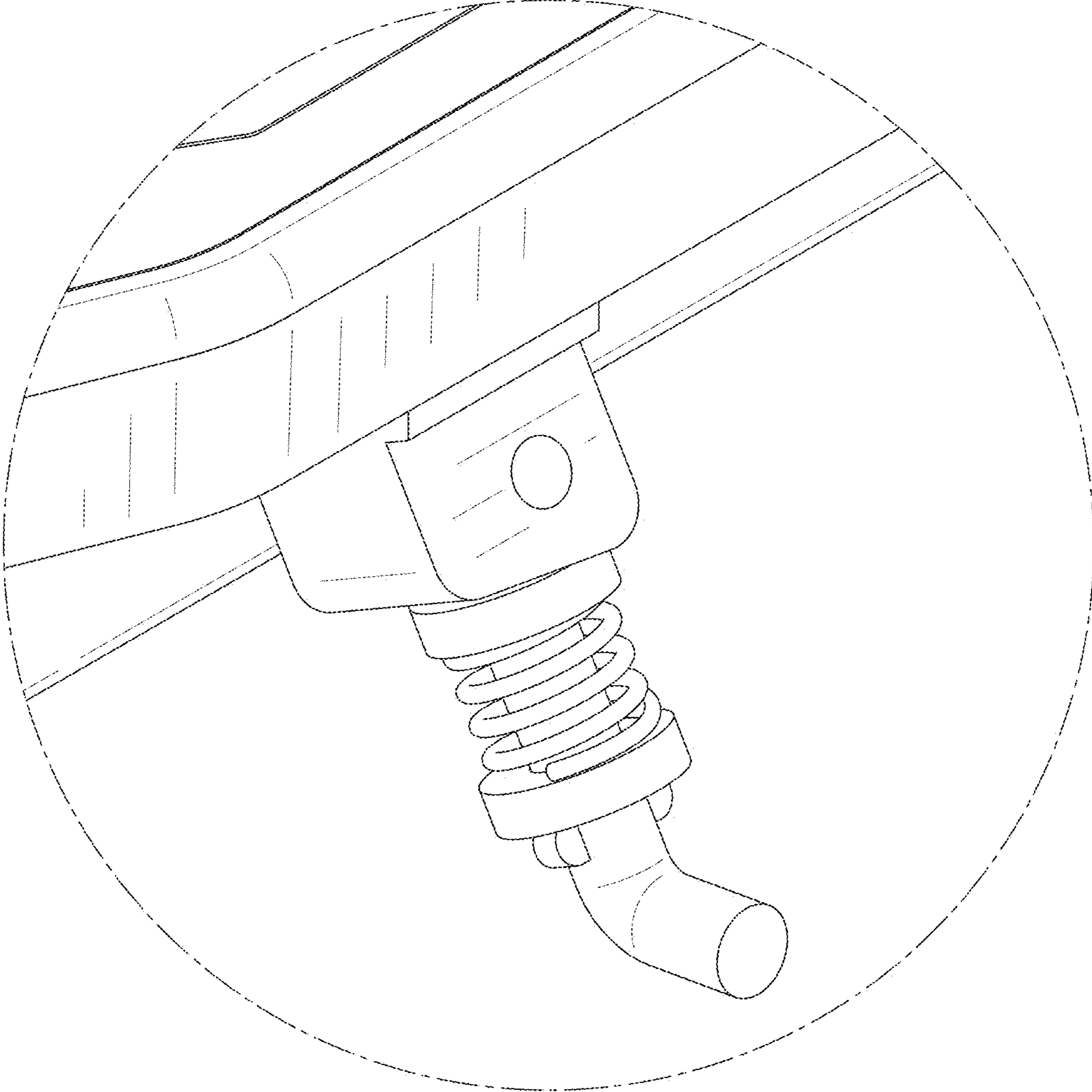

FIG. 11

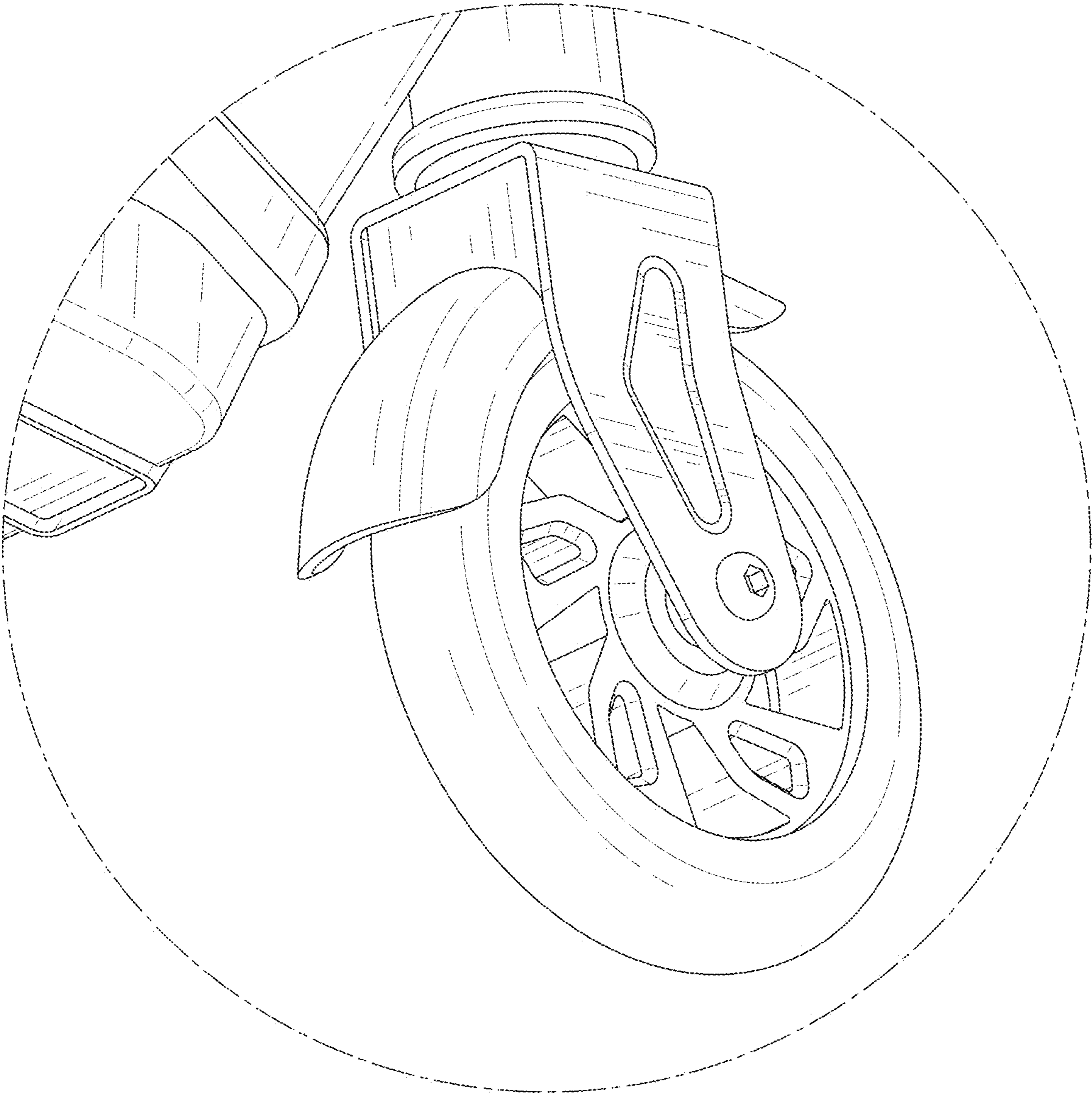

FIG. 12