



US00D943483S

(12) **United States Design Patent**
Chung

(10) **Patent No.:** **US D943,483 S**

(45) **Date of Patent:** **** Feb. 15, 2022**

(54) **AUTOMOTIVE WHEEL**

(71) Applicant: **Design Infini, Inc.**, Irvine, CA (US)

(72) Inventor: **Suny Chung**, Corona, CA (US)

(73) Assignee: **Design Infini, Inc.**, Irvine, CA (US)

(**) Term: **15 Years**

(21) Appl. No.: **29/666,321**

(22) Filed: **Oct. 11, 2018**

(51) **LOC (13) Cl.** **12-16**

(52) **U.S. Cl.**

USPC **D12/204**

(58) **Field of Classification Search**

USPC D12/204-213; D21/563

CPC B60B 7/00; B60B 7/02; B60B 7/04; B60B 7/01;
B60B 7/06; B60B 3/02; B60B 3/04;
B60B 3/06; B60B 3/10; B60B 1/00;
B60B 1/08; B60B 1/10; B60B 1/12

See application file for complete search history.

(56) **References Cited**

U.S. PATENT DOCUMENTS

D389,446 S *	1/1998	Bradley	D12/208
D433,369 S *	11/2000	Chung	D12/208
6,234,581 B1 *	5/2001	Stach	B60B 1/08
				301/64.102
D451,457 S *	12/2001	Hale, Jr.	D12/208
D503,369 S *	3/2005	Kato	D12/208
D578,946 S *	10/2008	Tirado	D12/208
D589,862 S *	4/2009	Cappellotto	D12/208
D730,259 S *	5/2015	Aydin	D12/208

D810,645 S *	2/2018	Sklyut	D12/204
D833,363 S *	11/2018	Chung	D12/213
D836,522 S *	12/2018	Prasad	D12/209

* cited by examiner

Primary Examiner — Stacia A Cadmus

(74) *Attorney, Agent, or Firm* — Knobbe, Martens, Olson & Bear, LLP

(57) **CLAIM**

I claim the ornamental design for an automotive wheel, as shown and described.

DESCRIPTION

FIG. 1 is perspective view of an automotive wheel, embodying my new design;

FIG. 2 is a cross-sectional view thereof, taken along lines 2-2 in FIG. 3; and,

FIG. 3 is a front view thereof.

The broken lines show features of the automobile wheel that form no part of the claimed design. The dot-dot-dash lines represent boundaries of the claimed design, and form no part of the claimed design. The dot-dot-dash outer boundary lines of the upper rim shown in FIG. 2 are unclaimed outer boundary lines. The dashed outer boundary lines of the lower rim are unclaimed and extend from the dot-dot-dash outer boundary lines of the upper rim. The recessed surface of the automobile wheel on which the central opening and six lug holes are shown in FIG. 1 is unclaimed. The outer circular dot-dot-dash line that surround the recessed surface is an unclaimed boundary line between the claimed upper rim and the unclaimed recessed surface. The cross-sectional surface shown in FIG. 2 includes solid hatching lines associated with claimed upper rim of the automobile wheel and dashed hatching lines associated with unclaimed lower rim.

1 Claim, 3 Drawing Sheets

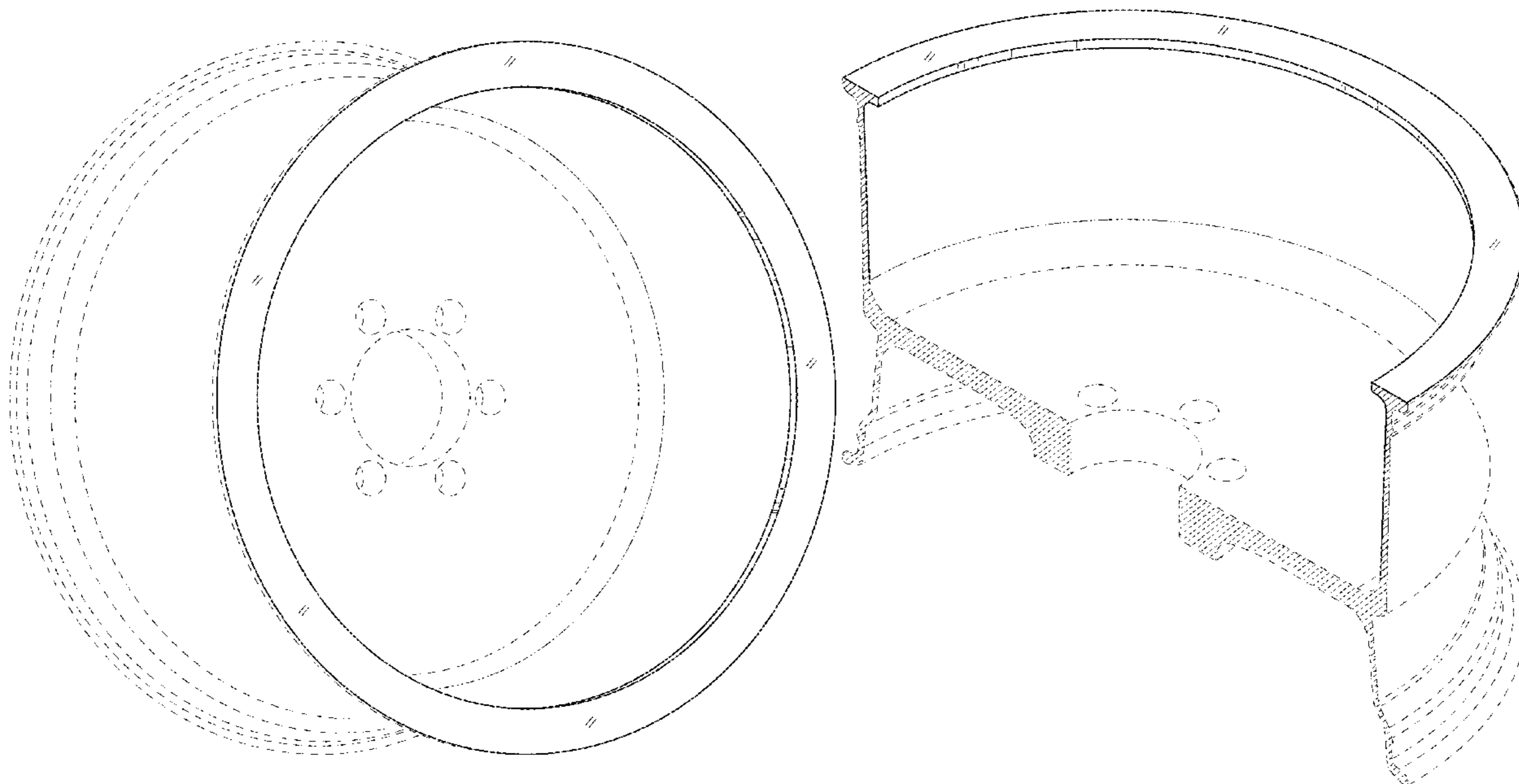

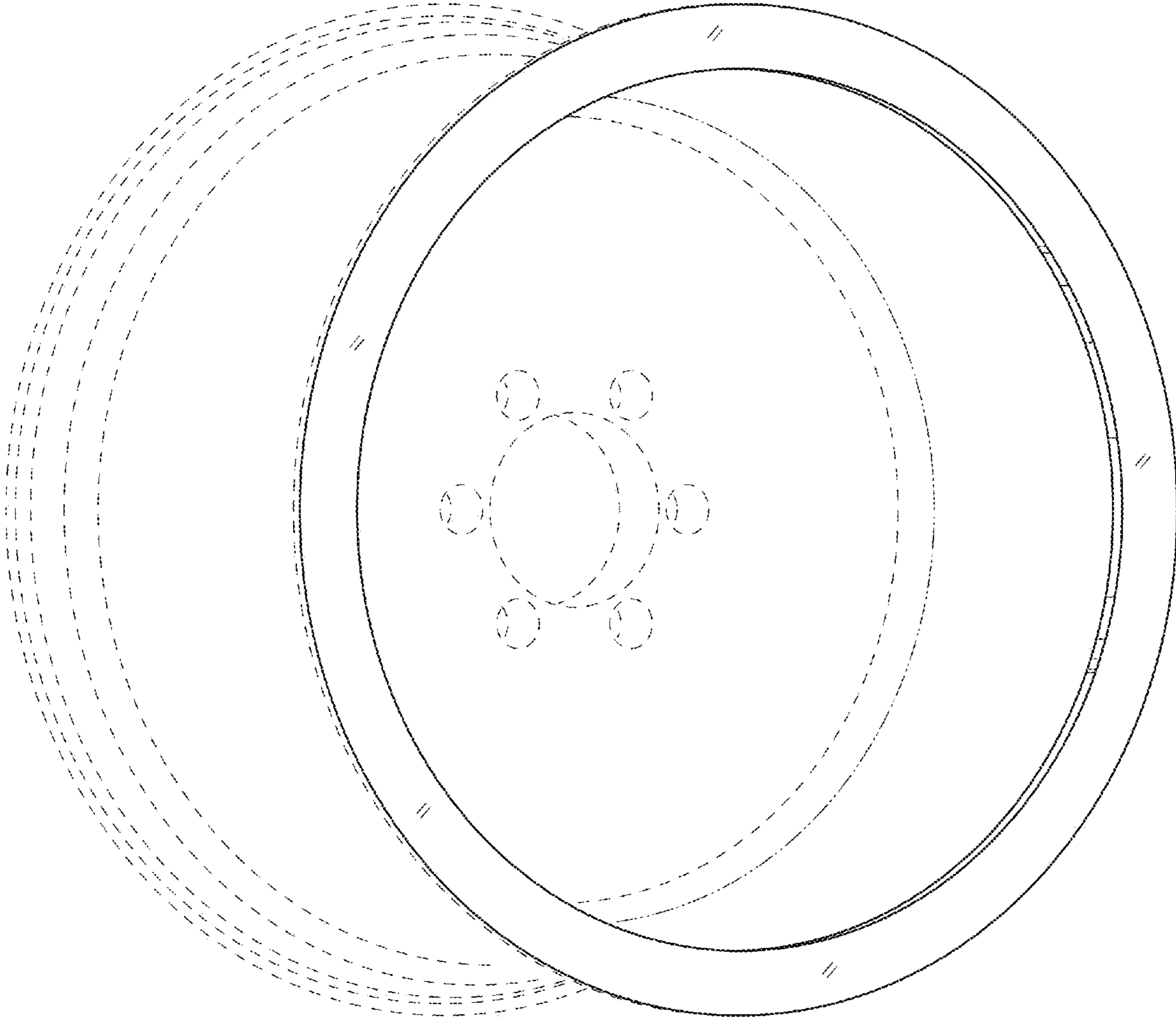

FIGURE 1

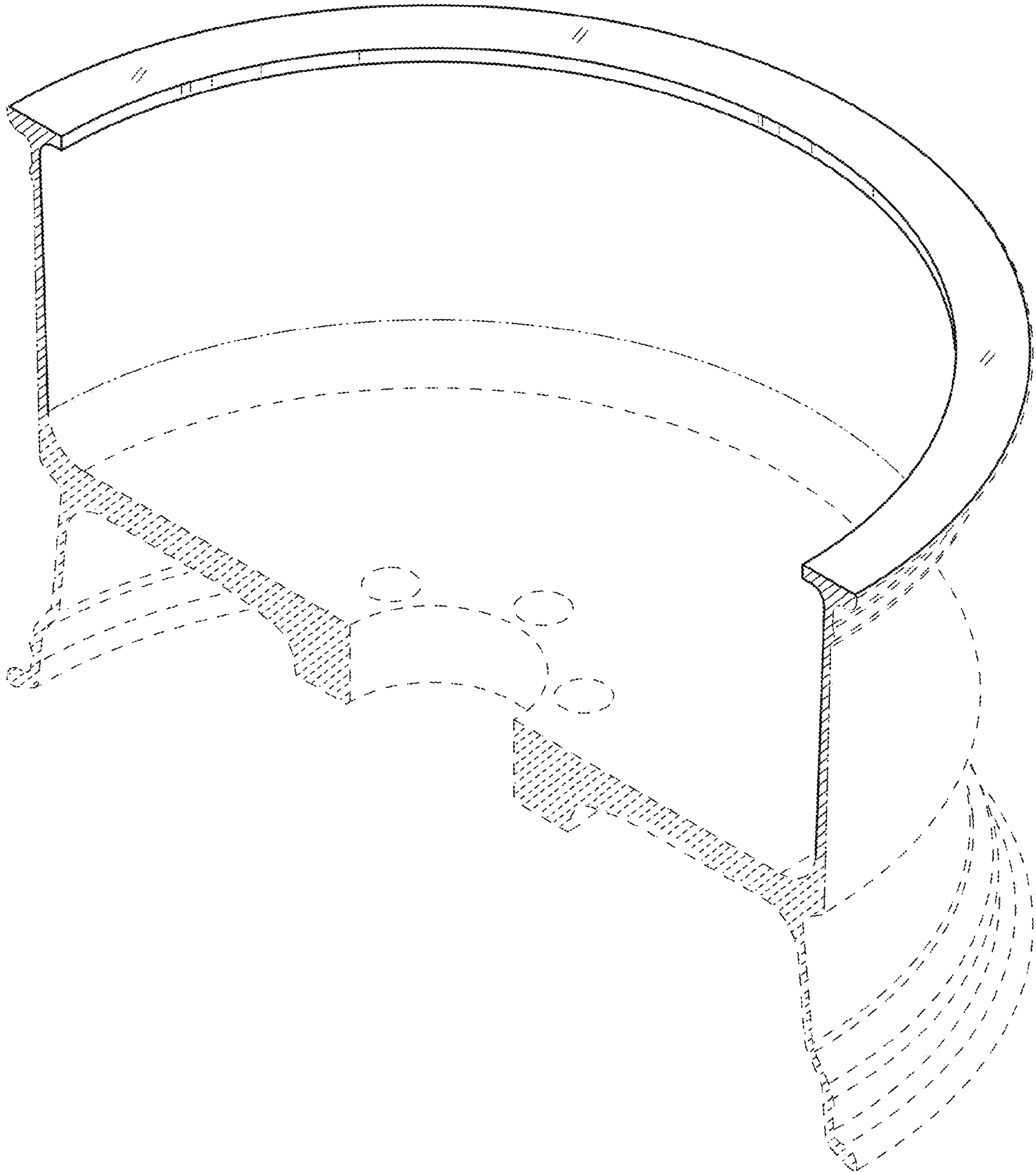

FIGURE 2

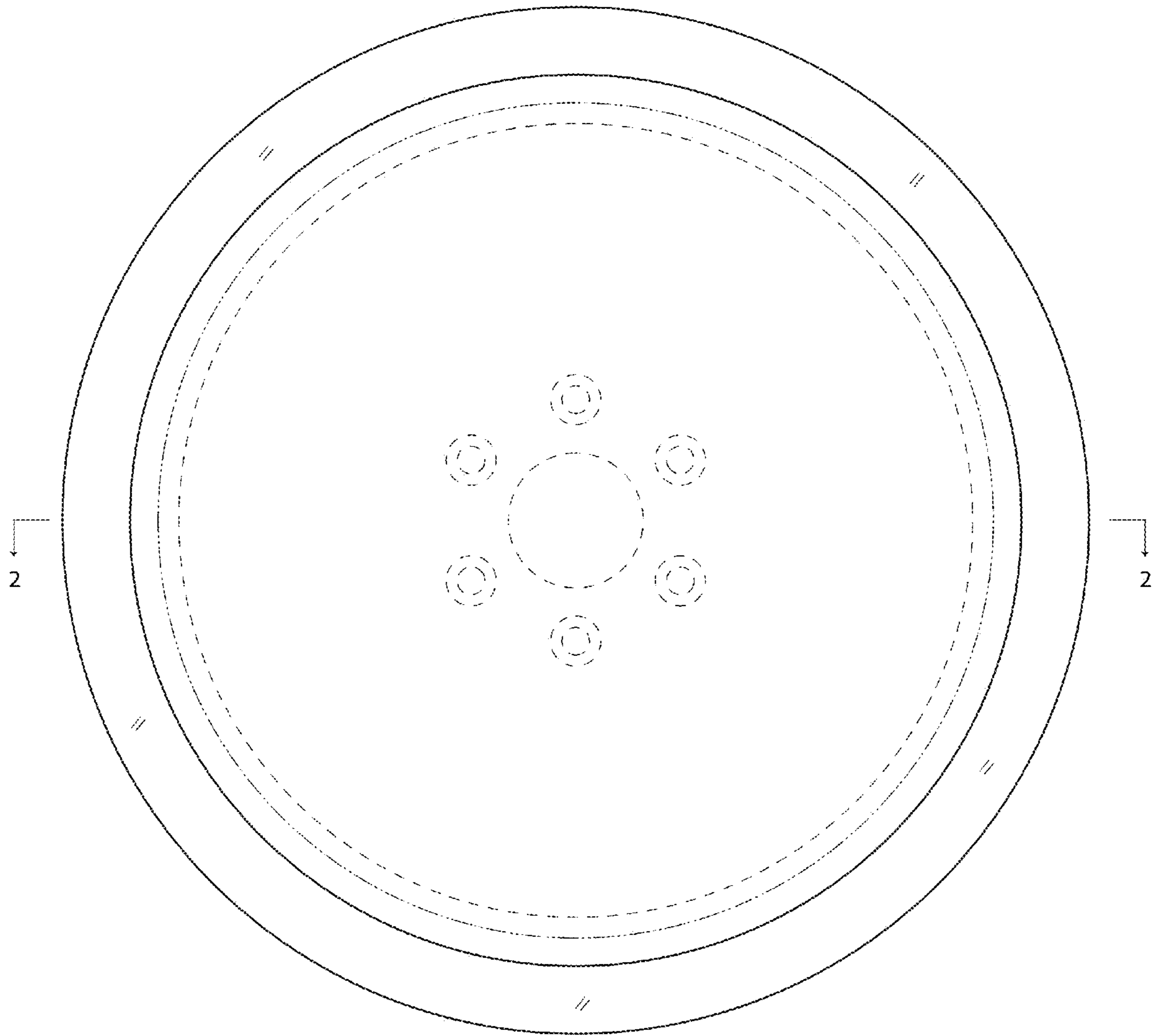

FIGURE 3