



US00D943429S

(12) **United States Design Patent** (10) **Patent No.:** **US D943,429 S**
Behling et al. (45) **Date of Patent:** **** *Feb. 15, 2022**

(54) **WATCH CASE**
(71) Applicant: **LVMH SWISS MANUFACTURES SA**, La Chaux-de-Fonds (CH)
(72) Inventors: **Christoph Behling**, London (GB); **Fabrice Gonet**, Ecublens (CH)
(*) Notice: This patent is subject to a terminal disclaimer.

D577,297 S * 9/2008 Lalo D10/32
D649,889 S * 12/2011 Giannini D10/32
D720,239 S * 12/2014 Mijatovic D10/32
D735,060 S * 7/2015 Monachon D10/32
D774,926 S * 12/2016 Butler D10/39
D809,940 S * 2/2018 Babcock D10/39
D833,302 S * 11/2018 Soares D10/39
D835,523 S * 12/2018 Pillot D10/39
D836,008 S * 12/2018 Schoepfer D10/39
D840,844 S * 2/2019 Le Bot D10/39

* cited by examiner

(**) Term: **15 Years**
(21) Appl. No.: **35/508,821**
(22) Filed: **Jul. 8, 2019**

Primary Examiner — George D. Kirschbaum

(80) **Hague Agreement Data**
Int. Filing Date: **Jul. 8, 2019**
Int. Reg. No.: **DM/206260**
Int. Reg. Date: **Jul. 8, 2019**
Int. Reg. Pub. Date: **Mar. 13, 2020**

(57) **CLAIM**

The ornamental design for a watch case, as shown and described.

(51) **LOC (13) Cl.** **10-02**
(52) **U.S. Cl.**
USPC **D10/30**
(58) **Field of Classification Search**
USPC D10/39, 32, 30
See application file for complete search history.

DESCRIPTION

FIG. 1.1 is a perspective view of watch case showing our new design;
FIG. 1.2 is a top view thereof;
FIG. 1.3 is a bottom view thereof;
FIG. 1.4 is a front view thereof;
FIG. 1.5 is a back view thereof;
FIG. 1.6 is a left view thereof; and
FIG. 1.7 is a right view thereof.

(56) **References Cited**

U.S. PATENT DOCUMENTS

D445,344 S * 7/2001 Haquet D10/30
D459,236 S * 6/2002 Haquet D10/30

1 Claim, 7 Drawing Sheets

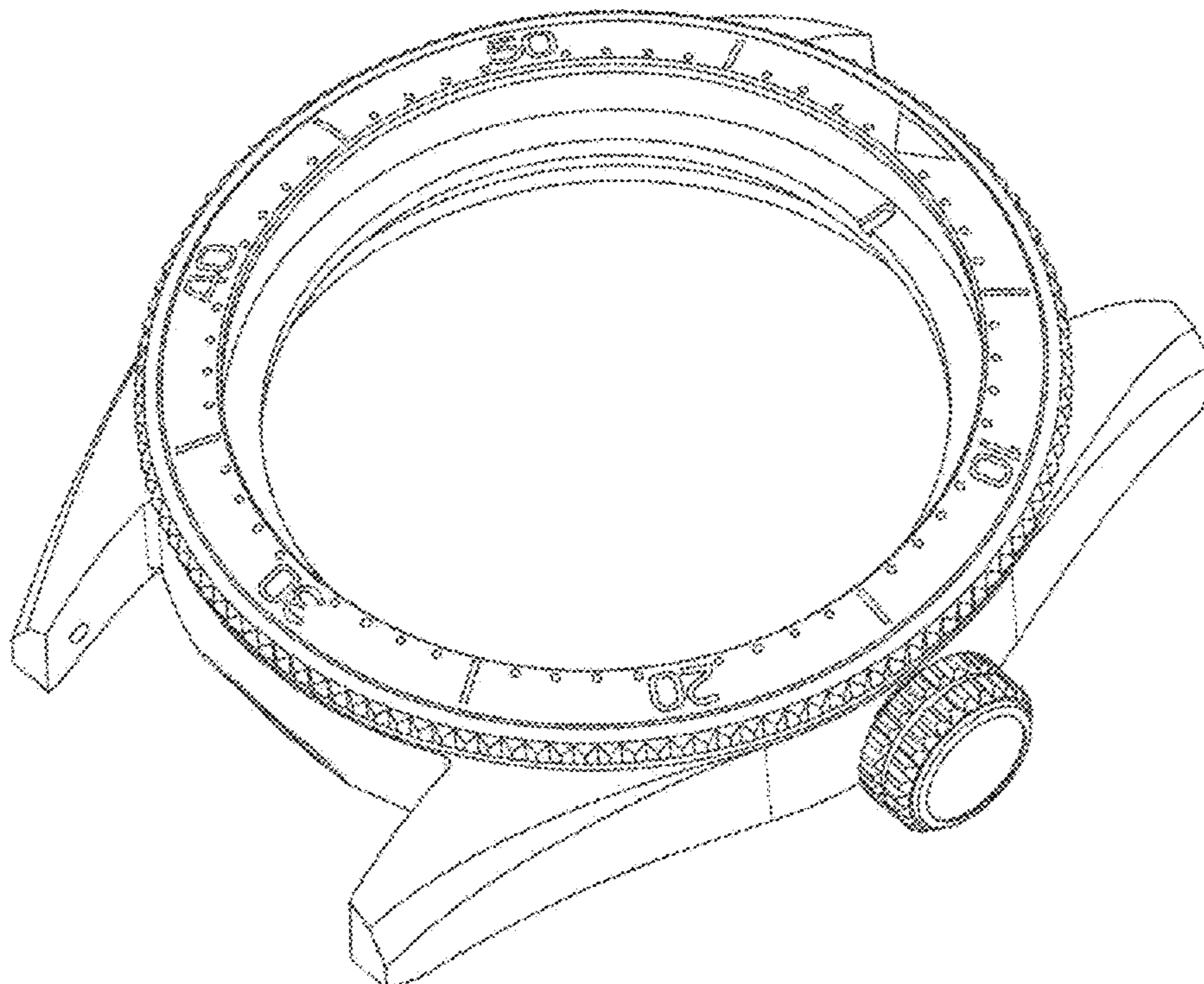

FIG. 1.1

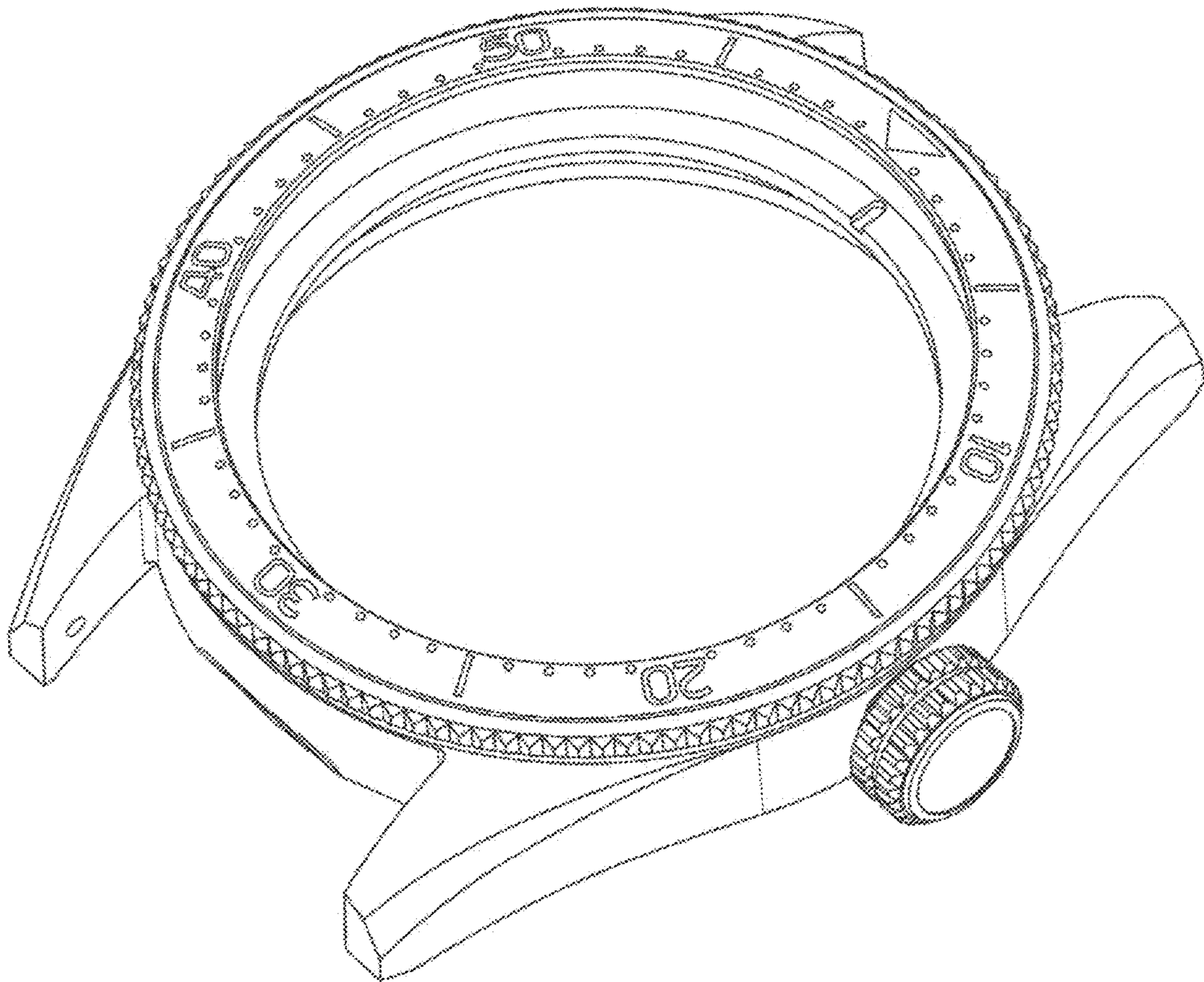

FIG. 1.2

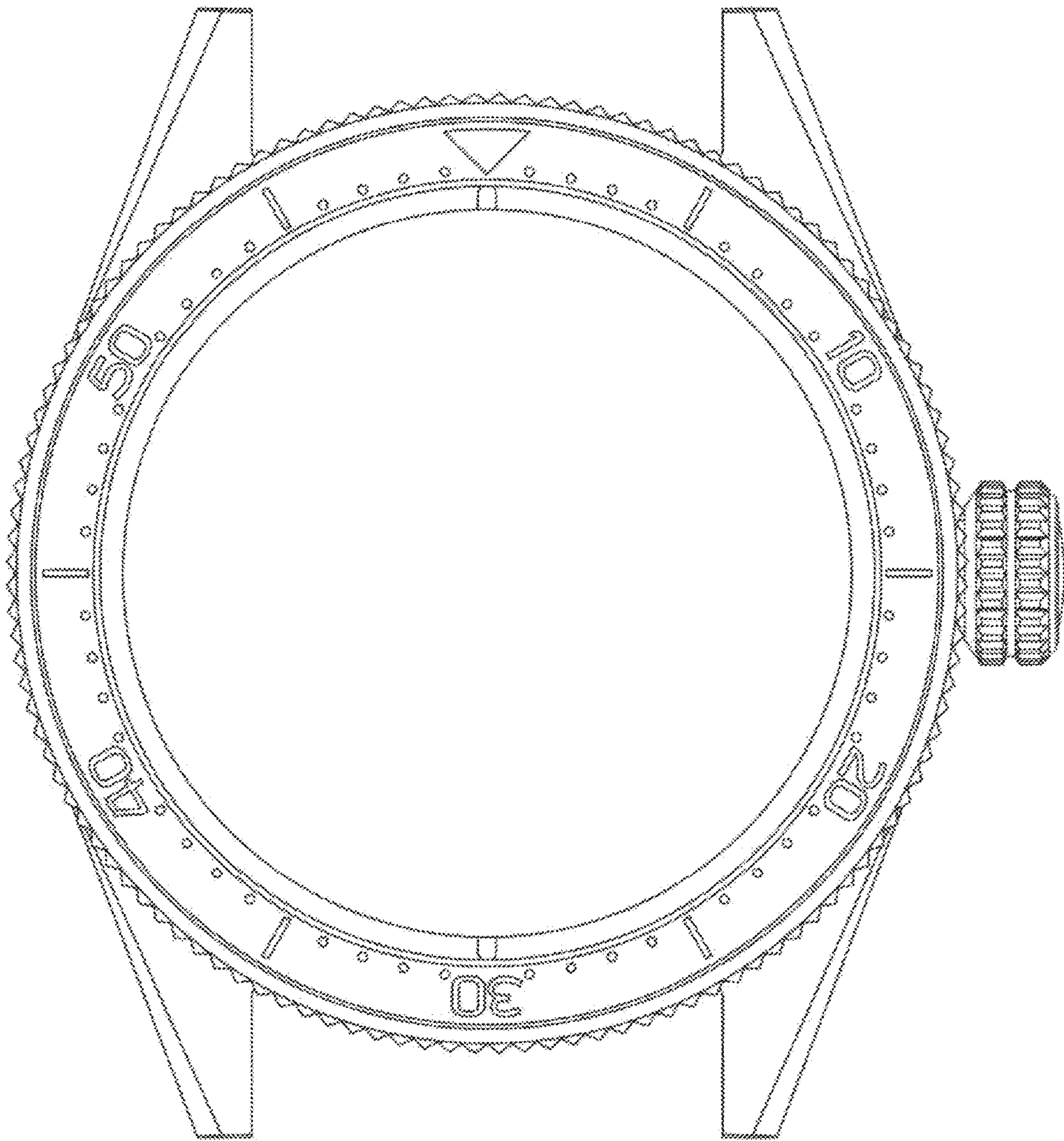

FIG. 1.3

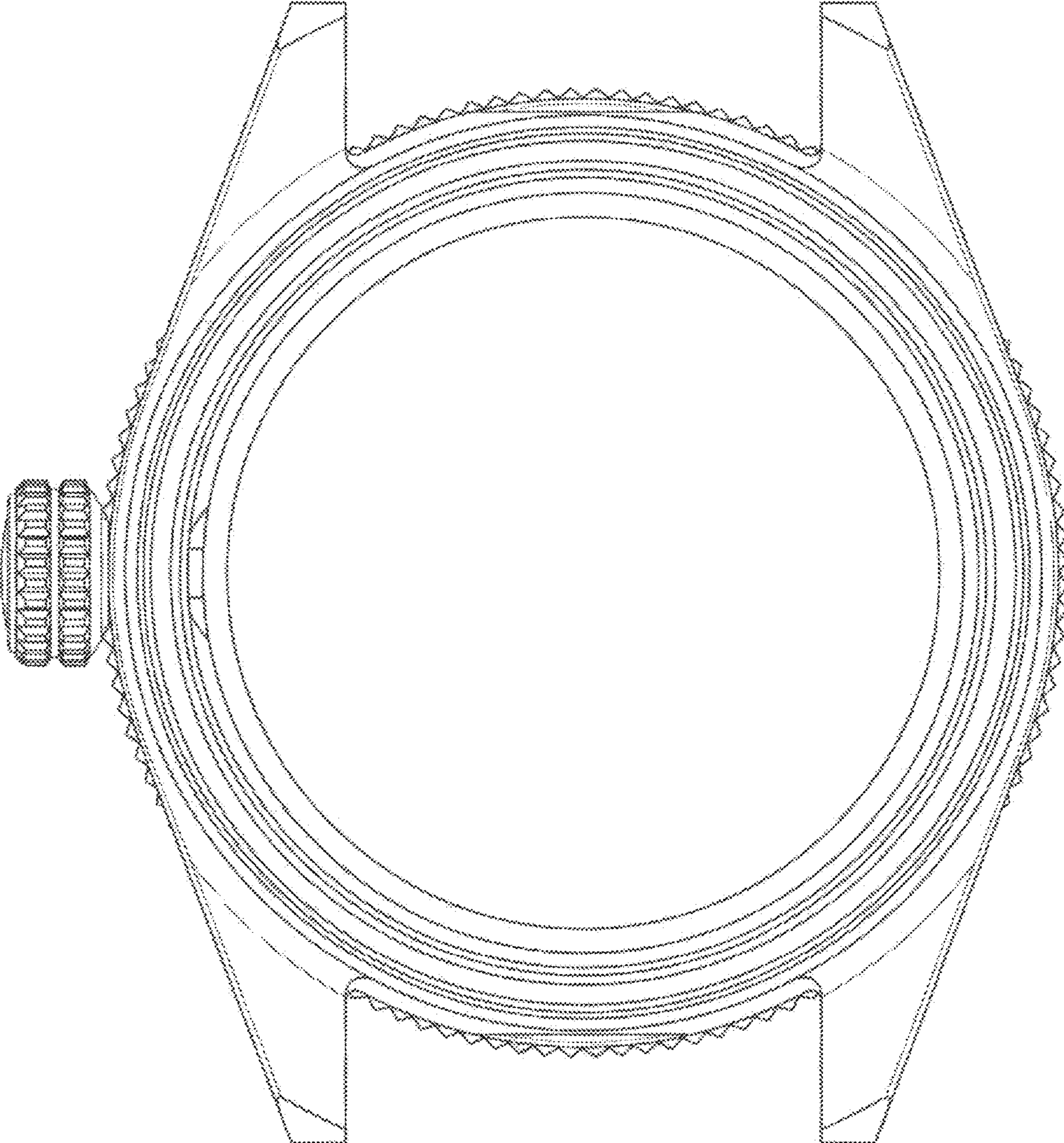

FIG. 1.4

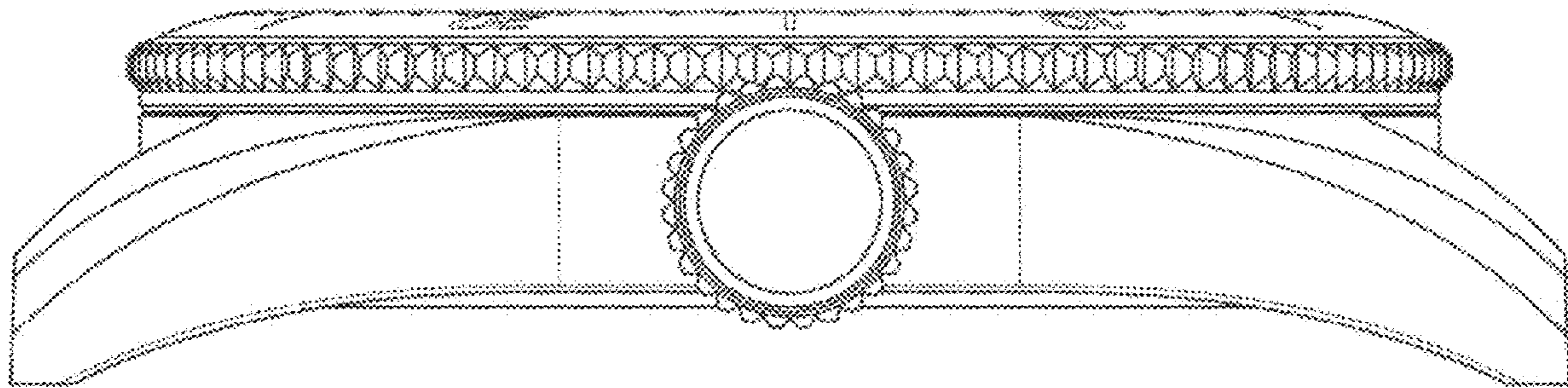

FIG. 1.5

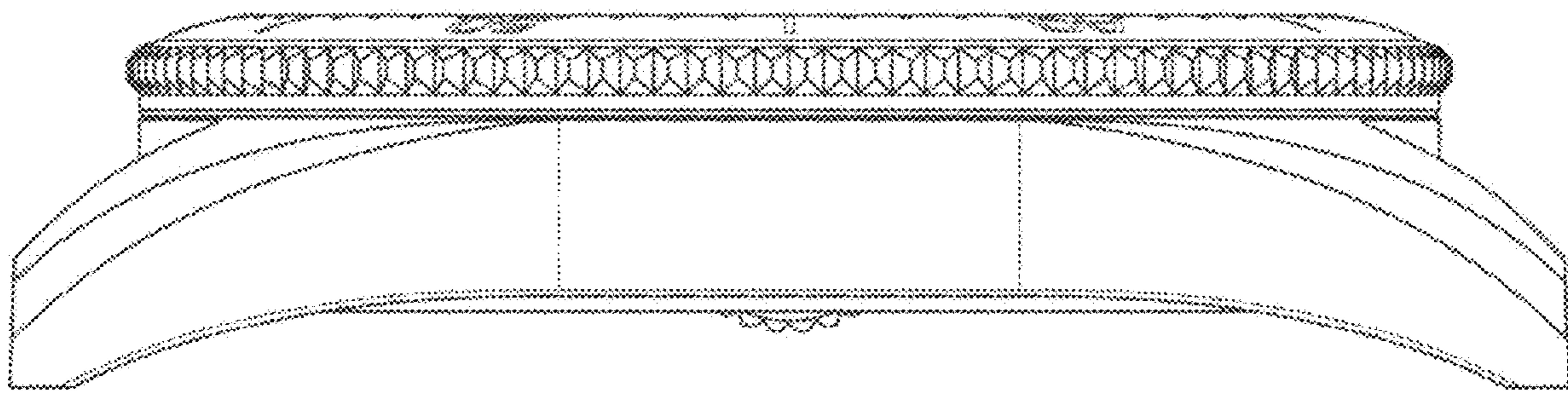

FIG. 1.6

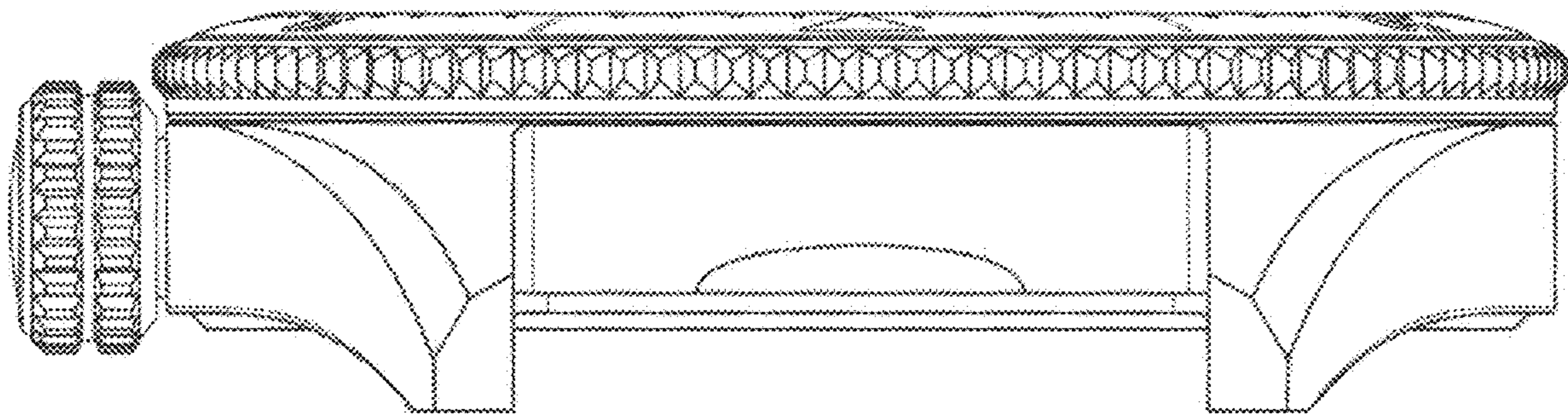
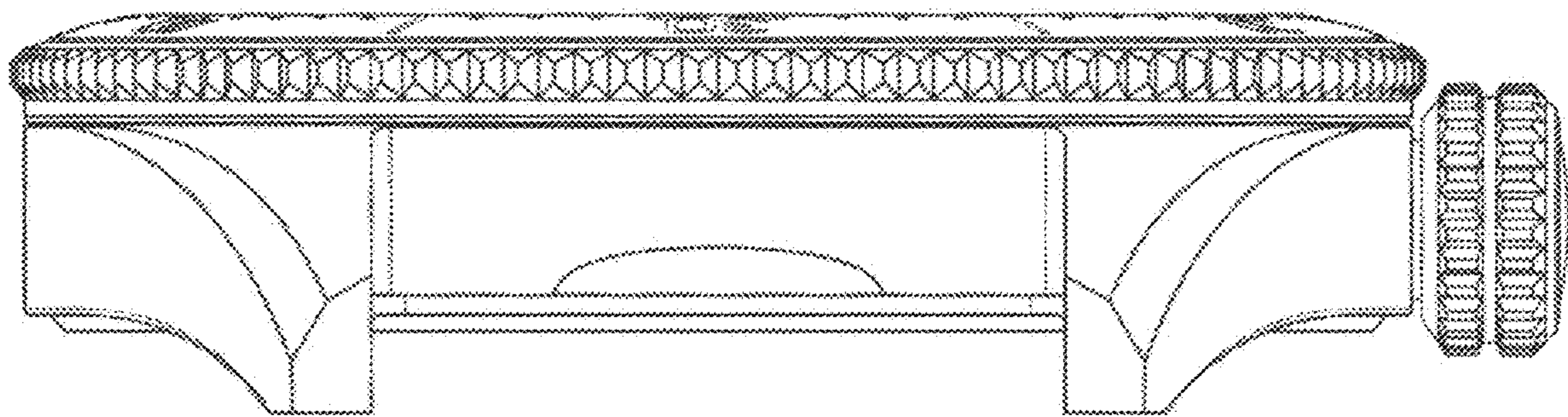

FIG. 1.7



UNITED STATES PATENT AND TRADEMARK OFFICE
CERTIFICATE OF CORRECTION

PATENT NO. : D943,429 S
APPLICATION NO. : 35/508821
DATED : February 15, 2022
INVENTOR(S) : Christoph Behling et al.

Page 1 of 1

It is certified that error appears in the above-identified patent and that said Letters Patent is hereby corrected as shown below:

On the Title Page

After item “(72)”, insert the following section:

--(73) Assignee: **LVMH Swiss Manufactures SA**, La Chaux-de-Fonds, (CH)--.

After item “(22)”, insert the following section:

--(30) **Foreign Application Priority Data**

Jan. 11, 2019 (WIPO) 970009018 (alternative no. WIPO 79106)--.

Signed and Sealed this
Twenty-fourth Day of May, 2022

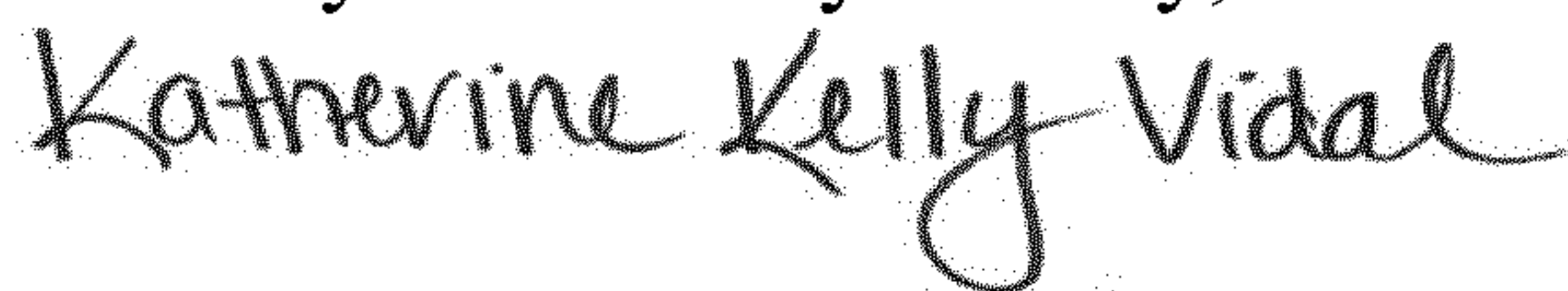

Katherine Kelly Vidal
Director of the United States Patent and Trademark Office