



US00D943032S

(12) **United States Design Patent**
Yao et al.

(10) **Patent No.:** **US D943,032 S**
(45) **Date of Patent:** **** Feb. 8, 2022**

(54) **MOTORIZED SCOOTER**

(71) Applicant: **ZHEJIANG TAOTAO VEHICLES CO., LTD**, Lishui (CN)
(72) Inventors: **Guangqing Yao**, Yongkang (CN); **Yuqiang Fu**, Henan Province (CN); **Hongxia Zhu**, Lishui (CN)

(**) Term: **15 Years**

(21) Appl. No.: **29/745,605**

(22) Filed: **Aug. 7, 2020**

(30) **Foreign Application Priority Data**

Jun. 19, 2020 (CN) 202030318961.3

(51) **LOC (13) Cl.** **21-01**

(52) **U.S. Cl.**
USPC **D21/423**

(58) **Field of Classification Search**
USPC D21/419, 421, 423, 760, 765, 771;
D12/1, 8, 107, 110, 112-114
CPC . B62K 3/002; B62K 9/00; B62K 9/02; B62K
2202/00; B62K 13/00; B62K 11/00;
B62K 11/02; B62K 11/06; B62K 11/10;
(Continued)

(56) **References Cited**

U.S. PATENT DOCUMENTS

D446,259 S * 8/2001 Udwin D21/423
D877,257 S * 3/2020 Cao B62B 13/04
D21/423

(Continued)

FOREIGN PATENT DOCUMENTS

CN 202574510 U * 12/2012 B62K 3/002
CN 108275236 A * 7/2018 B62J 11/10

(Continued)

OTHER PUBLICATIONS

Nick Start, "A Cyclone of Scooters Has Descended On Austin for SXSW, for Better or Worse," Mar. 11, 2019, theverge.com, site visited Aug. 23, 2021, URL: <https://www.theverge.com/2019/3/11/18260154/austin-scooters-bird-lime-uber-jump-sxsw-2019-dangerous-future-urban-transit> (Year: 2019).*

(Continued)

Primary Examiner — Eric L Goodman
Assistant Examiner — Sarah L Smith

(57) **CLAIM**

The ornamental design for a motorized scooter, as shown and described.

DESCRIPTION

FIG. 1 is a front and top perspective view of a motorized scooter, showing our new design;
FIG. 2 is a rear and bottom perspective view thereof;
FIG. 3 is a front elevational view thereof;
FIG. 4 is a rear elevational view thereof;
FIG. 5 is a left side elevational view thereof;
FIG. 6 is a right side elevational view thereof;
FIG. 7 is a top plan view thereof;
FIG. 8 is a bottom plan view thereof.
FIG. 9 is an enlarged view of a front wheel in FIG. 1;
FIG. 10 is an enlarged view of a rear wheel in FIG. 1;
FIG. 11 is an enlarged view of a handle in FIG. 1;
FIG. 12 is an enlarged view of a connector in FIG. 1;
FIG. 13 is an enlarged view of a front wheel in FIGS. 2; and
FIG. 14 is an enlarged view of a rear wheel in FIG. 2.
The dashed broken lines in the figures illustrate portions of the article that form no part of the claimed design. The dash dot dash lines in FIGS. 1-2 and 9-14 are for the purpose of depicting the boundary lines of the enlarged view and form no part of the claim.

1 Claim, 14 Drawing Sheets

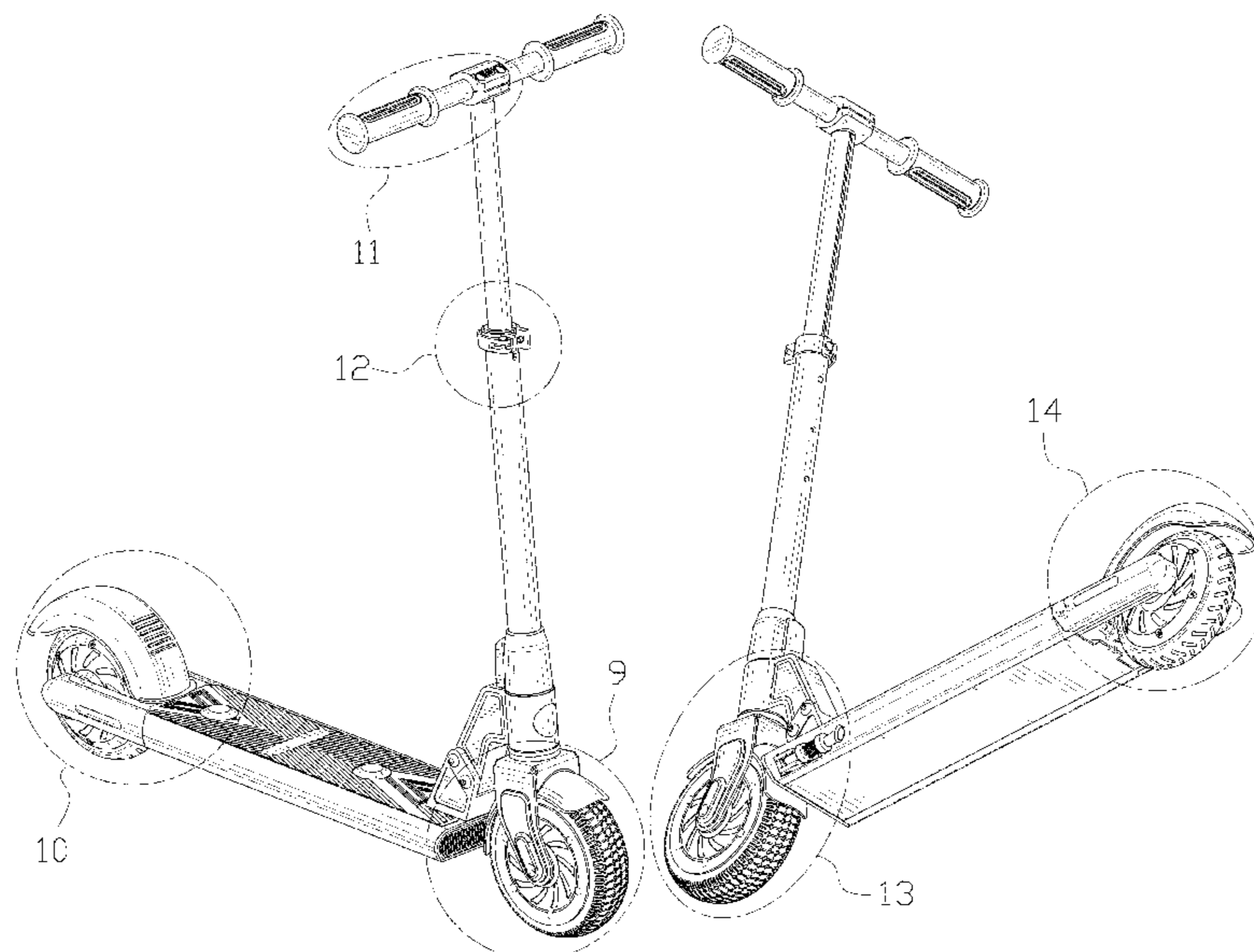

(58) **Field of Classification Search**

CPC .. B62K 15/00; B62K 17/00; B60Y 2200/126;
H04W 4/40

See application file for complete search history.

2014/0196968 A1* 7/2014 Bieler B62M 6/65
180/181
2016/0107718 A1* 4/2016 O Connell B60T 7/06
280/87.041
2019/0263468 A1* 8/2019 Huang B60K 17/26
2020/0102032 A1* 4/2020 Huang B62H 5/04
2020/0361560 A1* 11/2020 Claes B62H 5/003

(56) **References Cited**

U.S. PATENT DOCUMENTS

D877,258 S * 3/2020 Cao B62K 15/006
D21/423
D889,557 S * 7/2020 Cao B62H 5/04
D21/423
D905,793 S * 12/2020 Yang D21/423
D914,103 S * 3/2021 Cao D21/423
D915,524 S * 4/2021 Cao D21/423
D919,712 S * 5/2021 Gao D21/423
2002/0084605 A1* 7/2002 Lu B62B 13/04
280/14.28
2002/0093161 A1* 7/2002 Udwin B62K 15/006
280/87.05
2003/0221888 A1* 12/2003 McKinney, Jr. B62K 3/002
180/181
2013/0257003 A1* 10/2013 Chen B62K 21/12
280/87.041
2014/0061267 A1* 3/2014 Turner B62J 7/06
224/413

FOREIGN PATENT DOCUMENTS

CN 304743288 * 7/2018 B62K 3/002
CN 108357611 A * 8/2018 B62K 3/002
CN 305367612 * 9/2019
DE 102018107492 A1 * 10/2019 B62K 3/002
DE 102019007916 A1 * 5/2021 B62K 3/002
EM 006147617-0008 * 2/2019
EM 006770673-0002 * 10/2019
EP 3712048 A1 * 9/2020 B62J 11/10
EP 3738868 A1 * 11/2020 B62J 50/225
WO WO-2013120111 A1 * 8/2013 B62K 3/002

OTHER PUBLICATIONS

“Pureelectric_uk Now that’s how to end a Monday,” Jun. 24, 2019,
instagram.com, site visited Aug. 23, 2021, URL: <https://www.instagram.com/p/BzGkqwhBYY7/> (Year: 2019).*

* cited by examiner

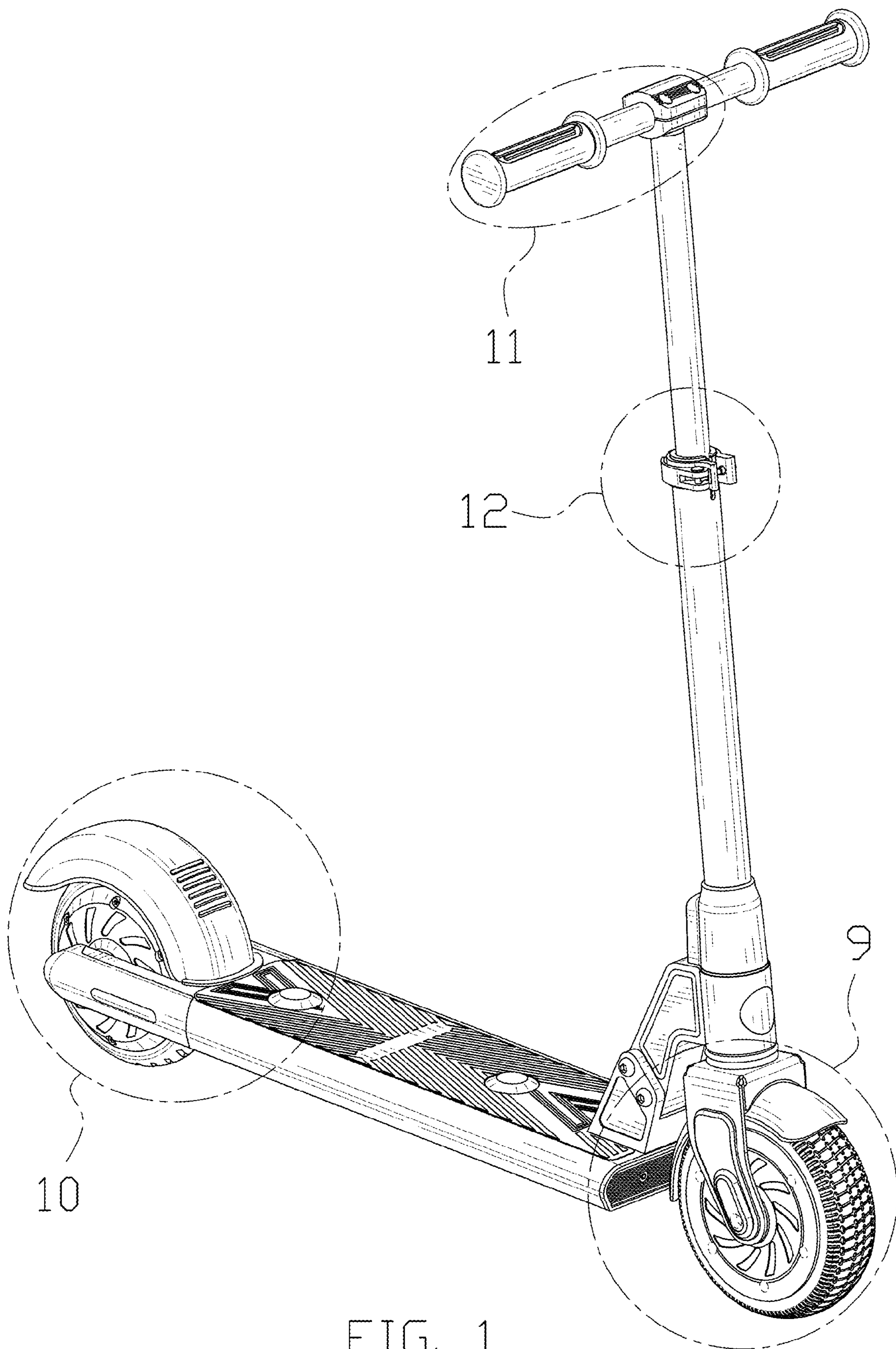

FIG. 1

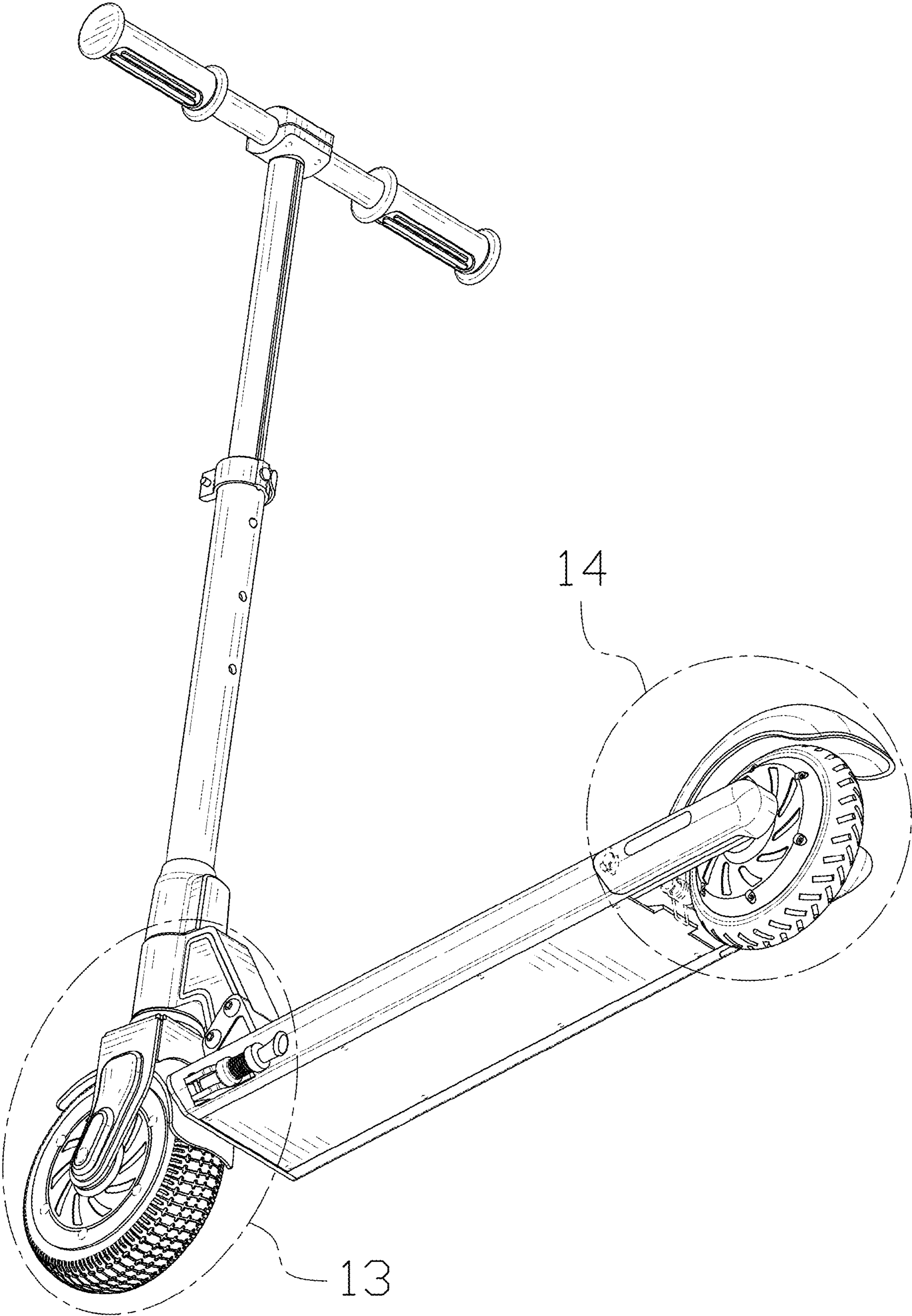

FIG. 2

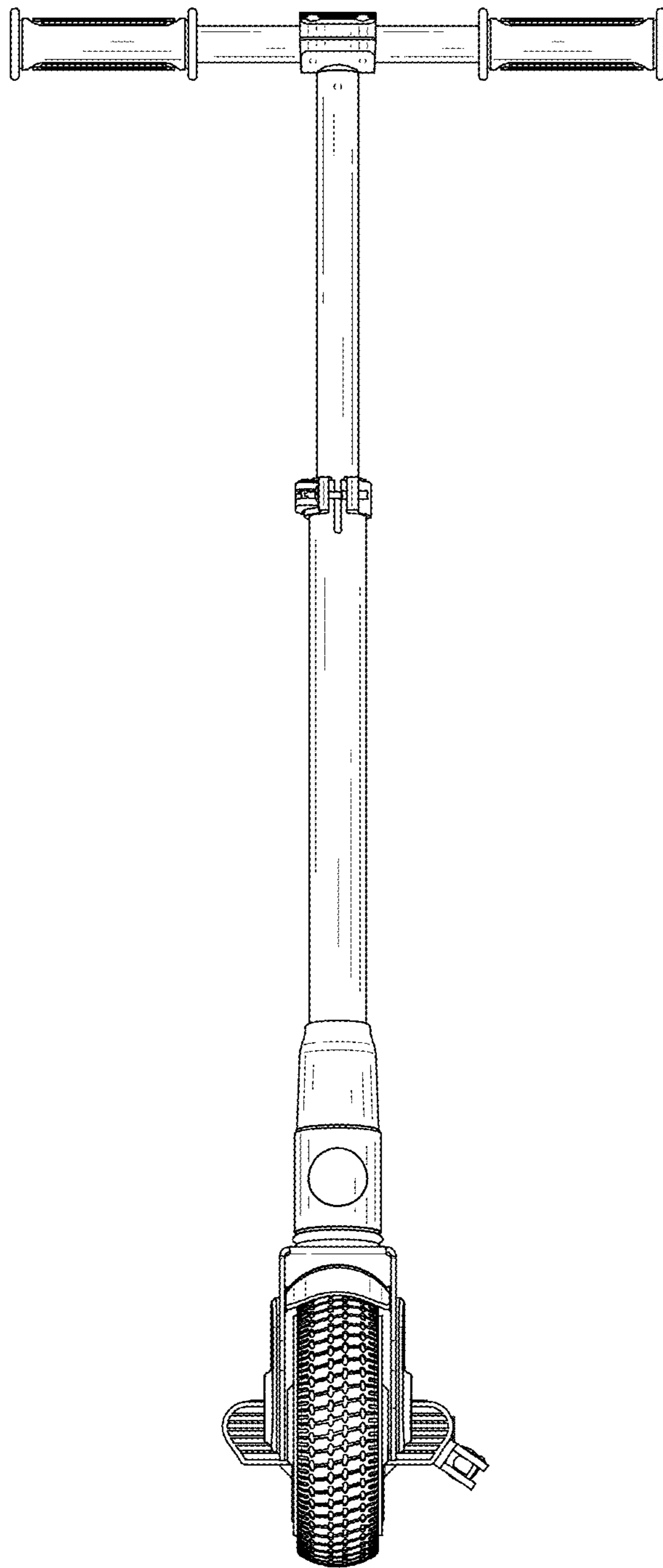

FIG. 3

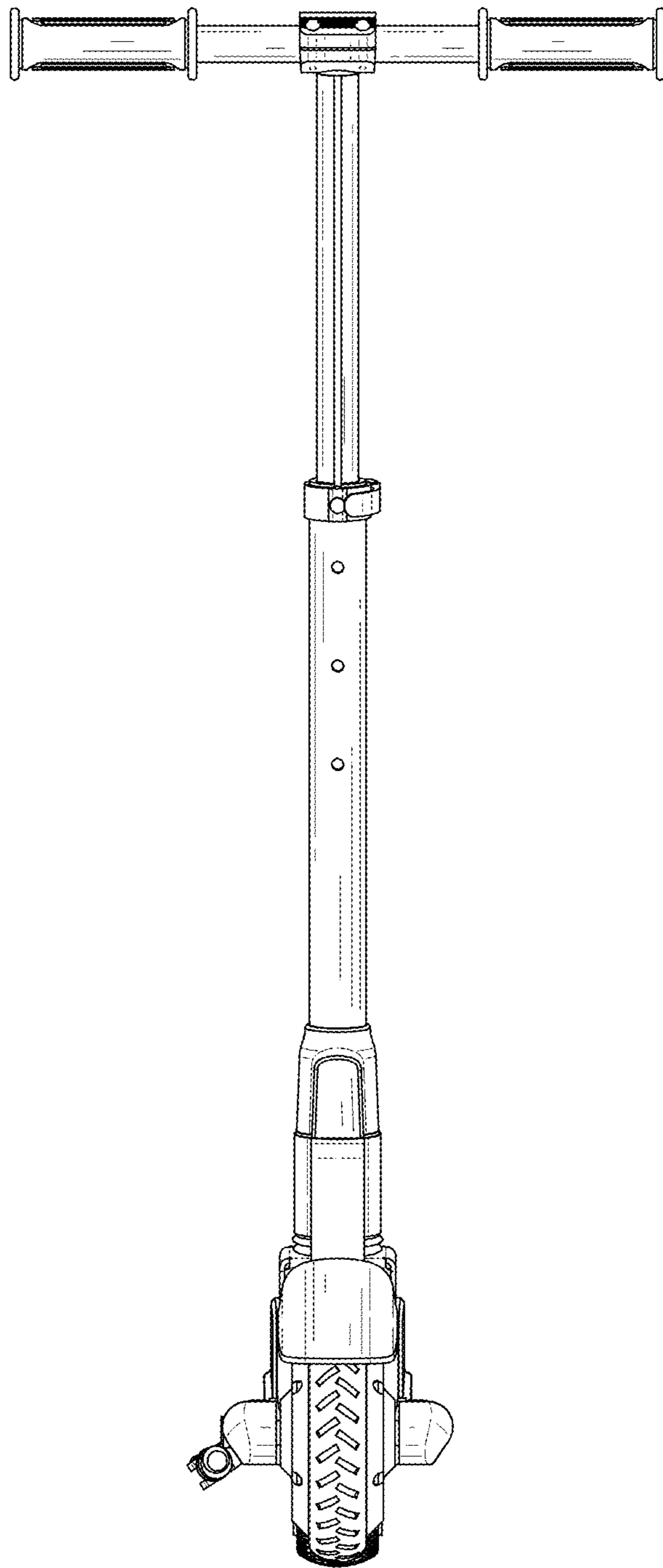

FIG. 4

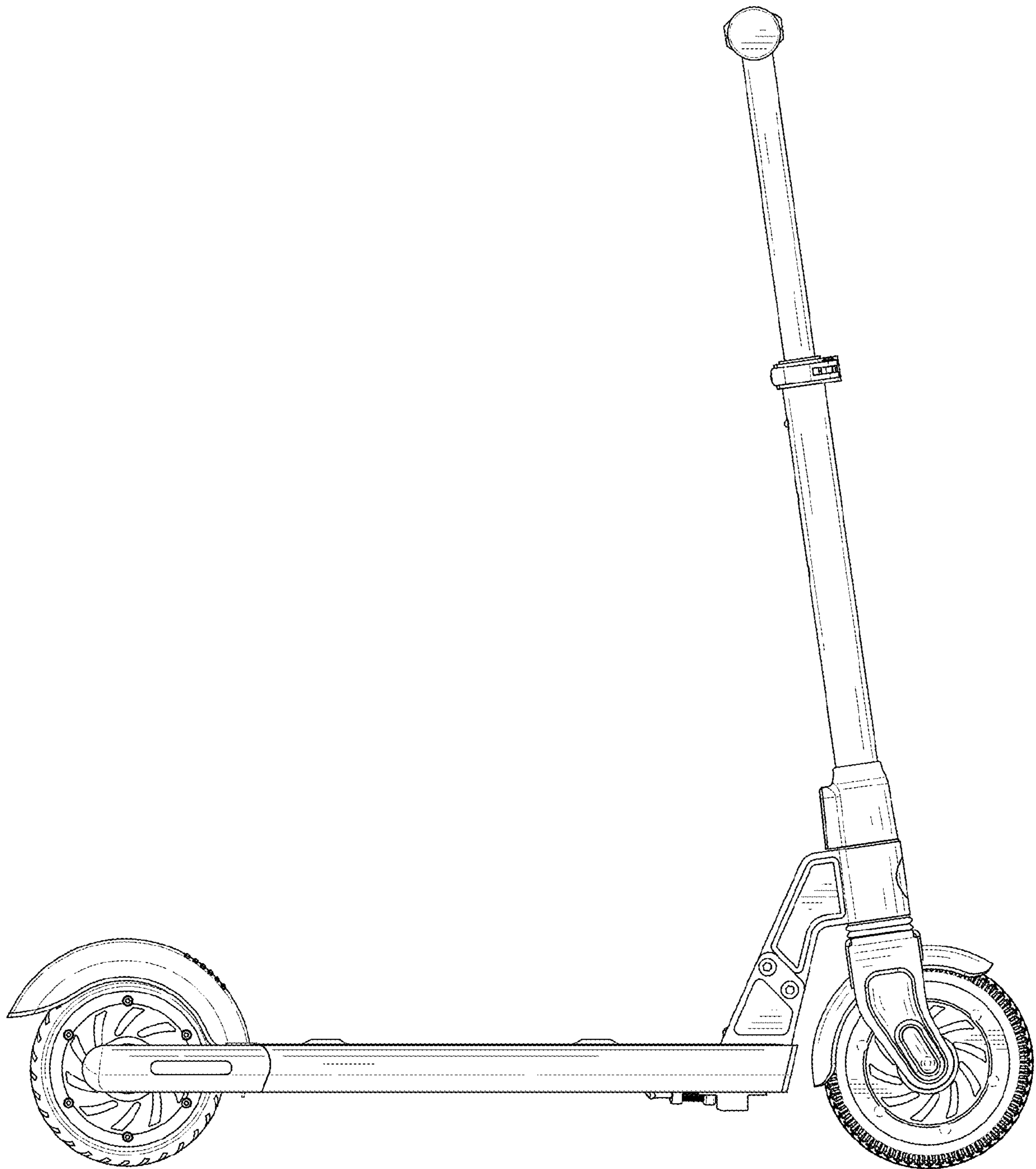

FIG. 5

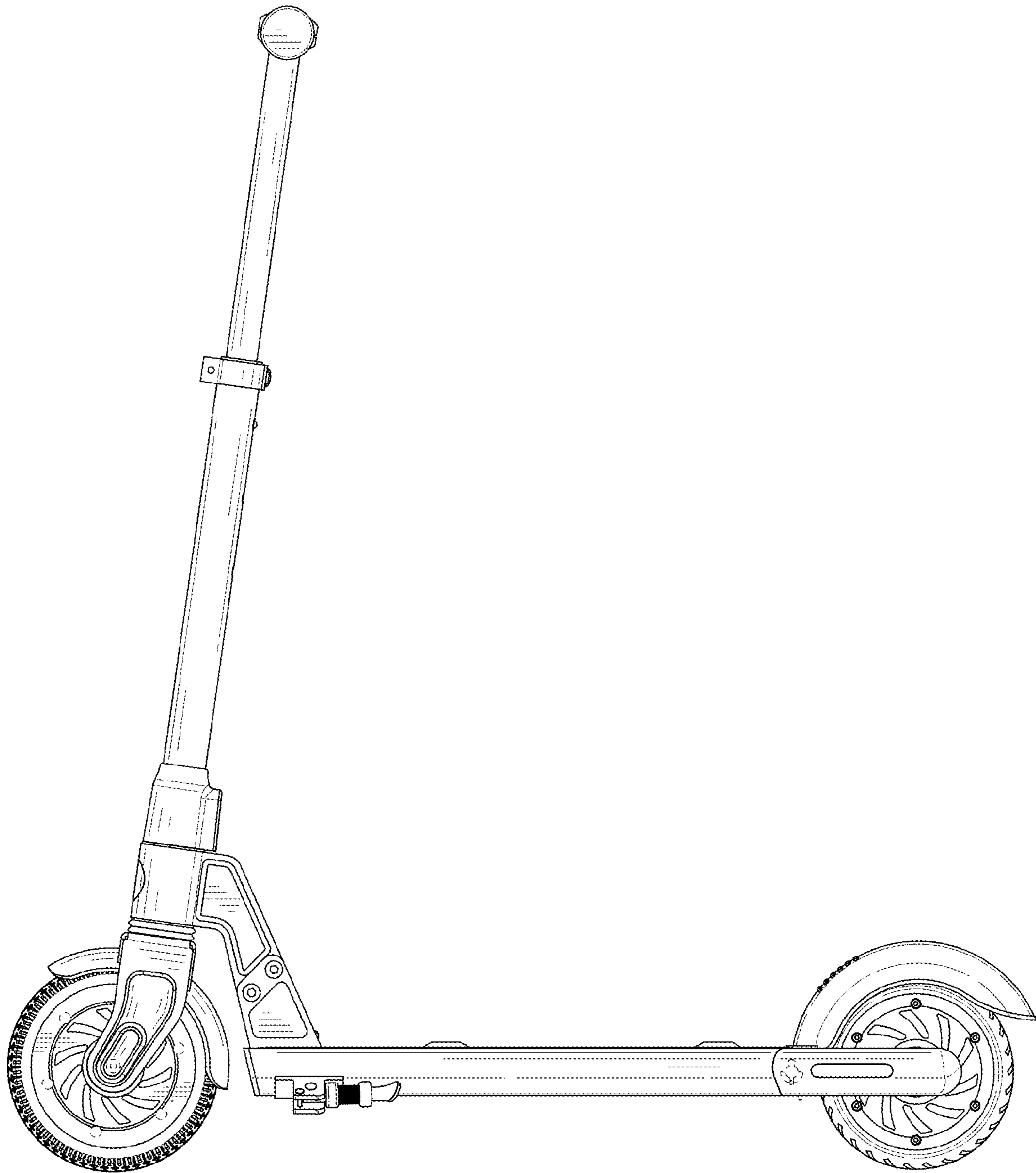

FIG. 6

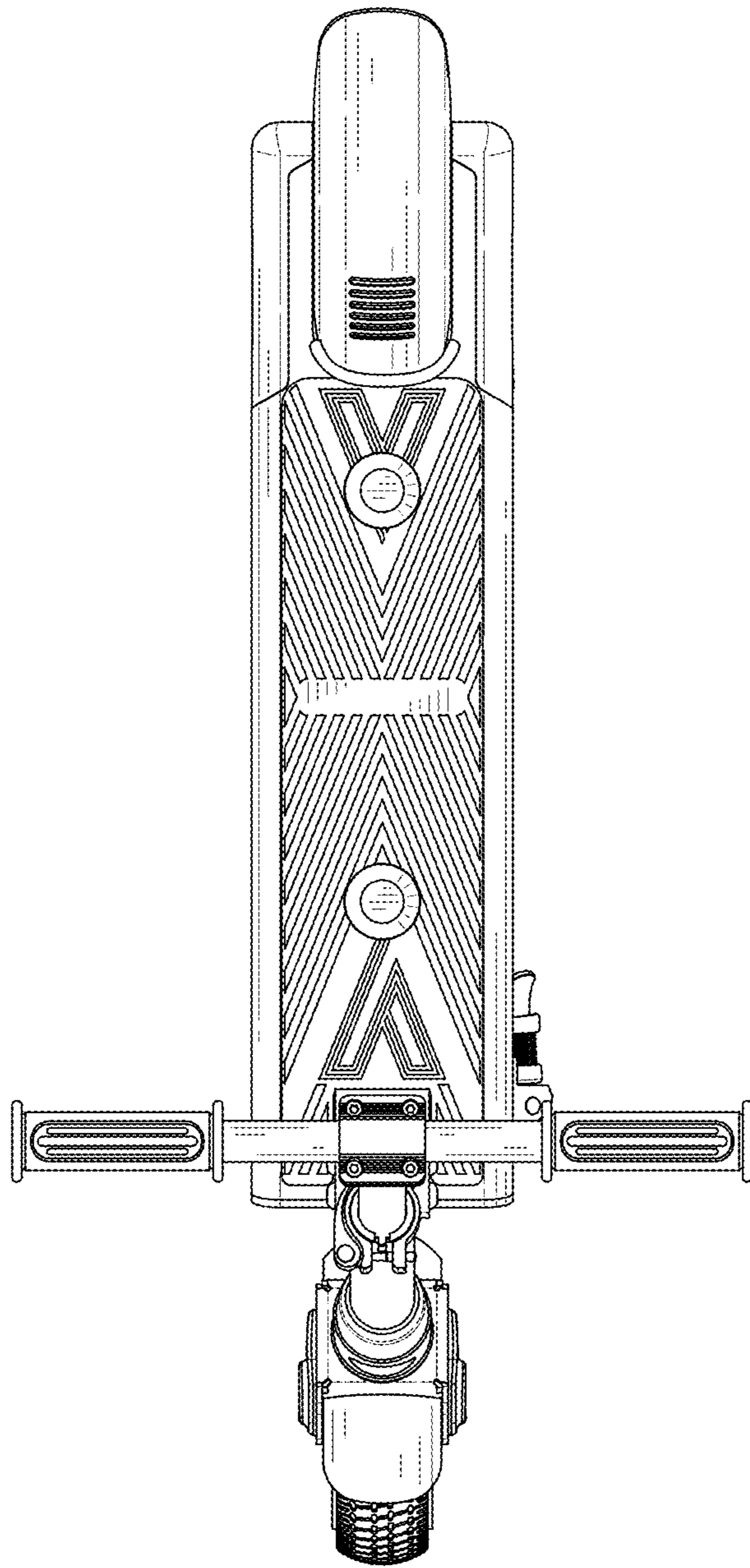

FIG. 7

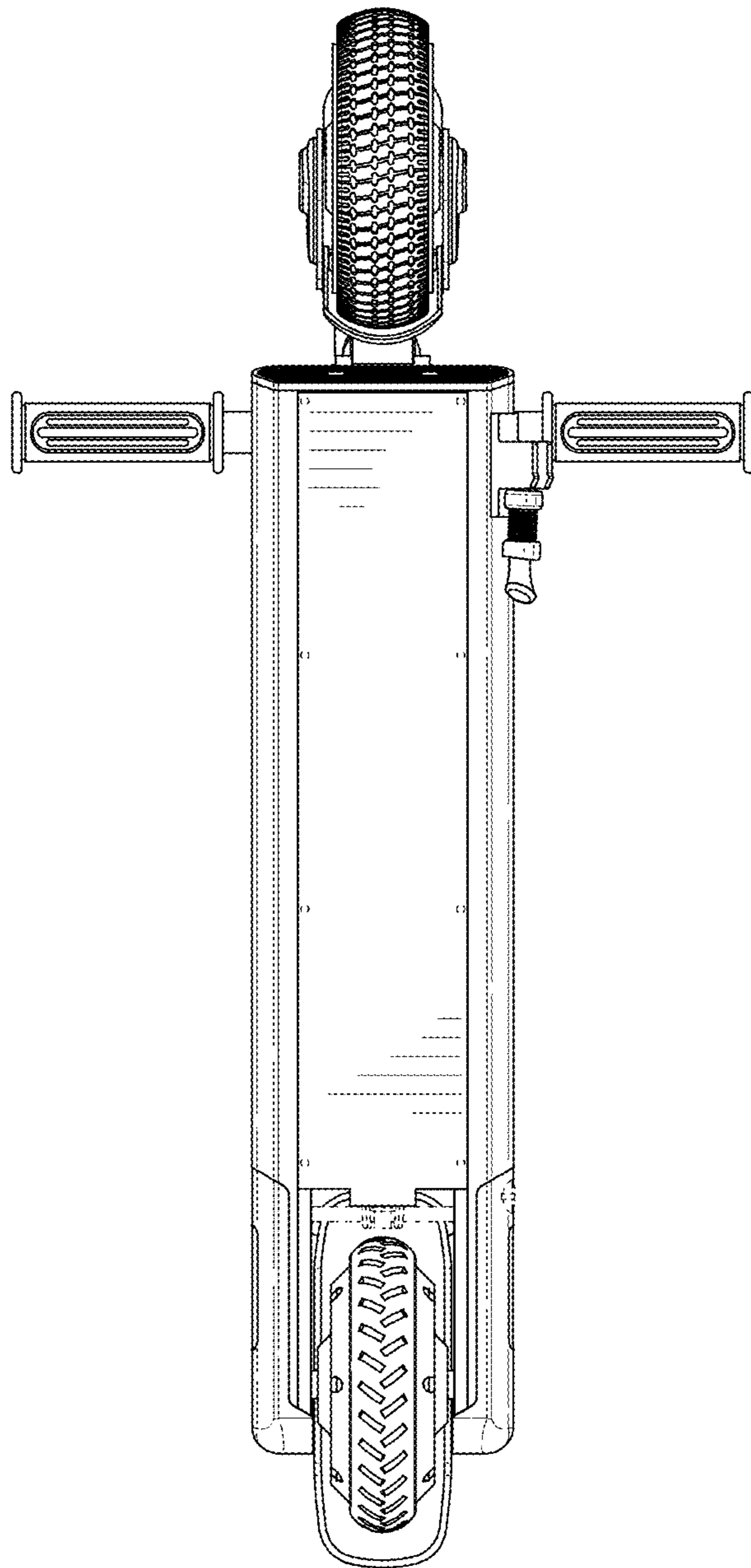

FIG. 8

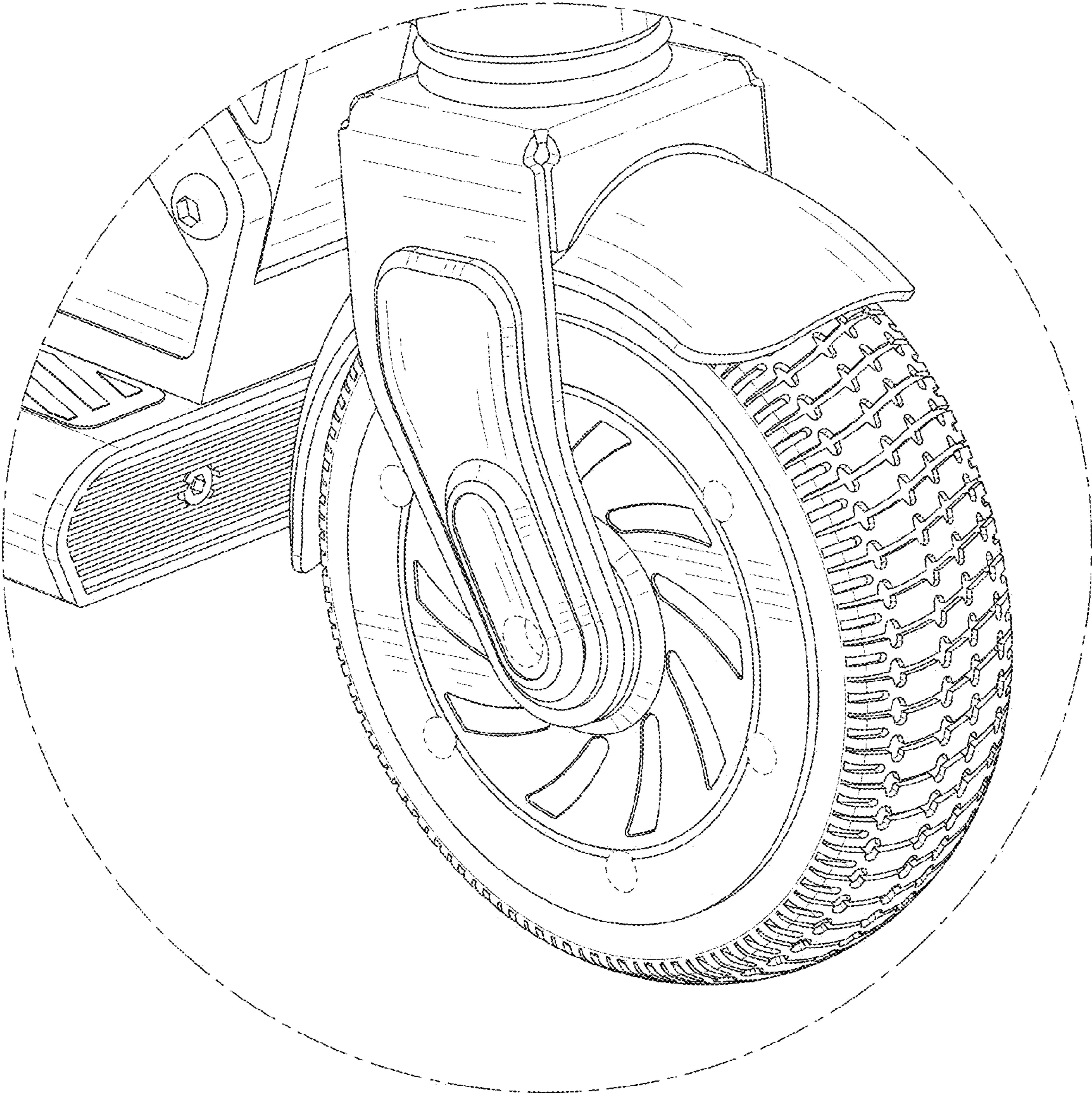

FIG. 9

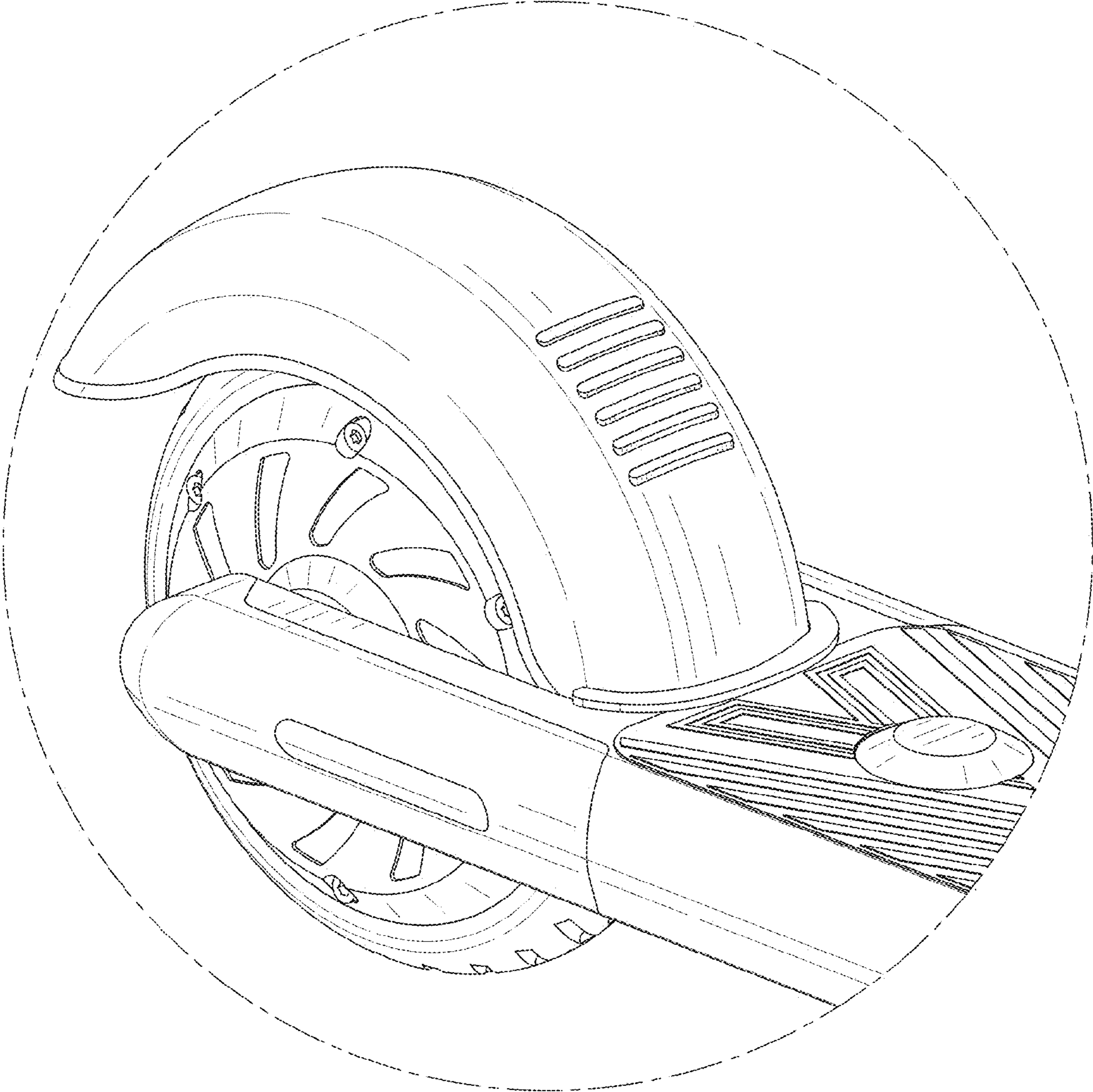

FIG. 10

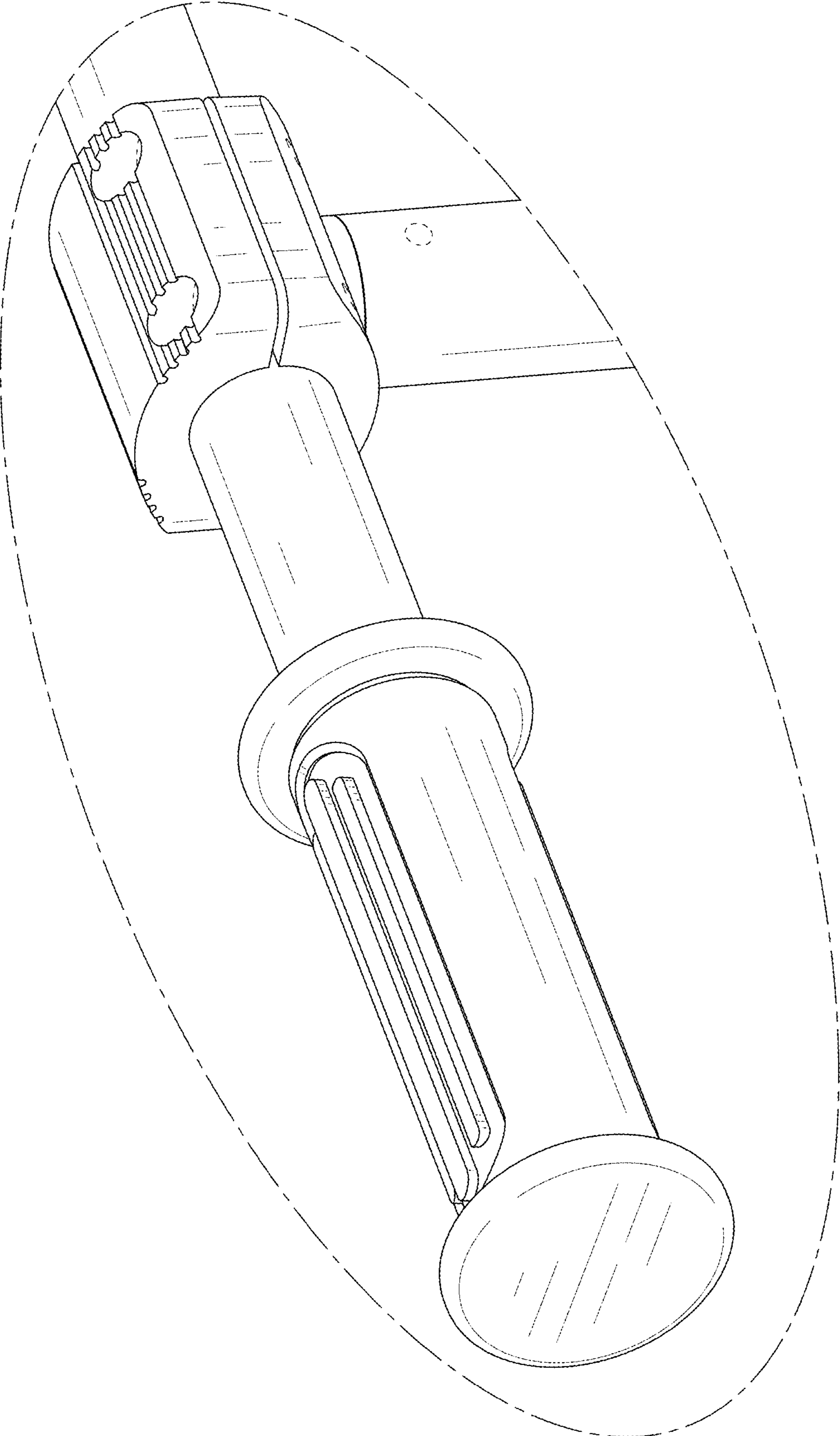

FIG. 11

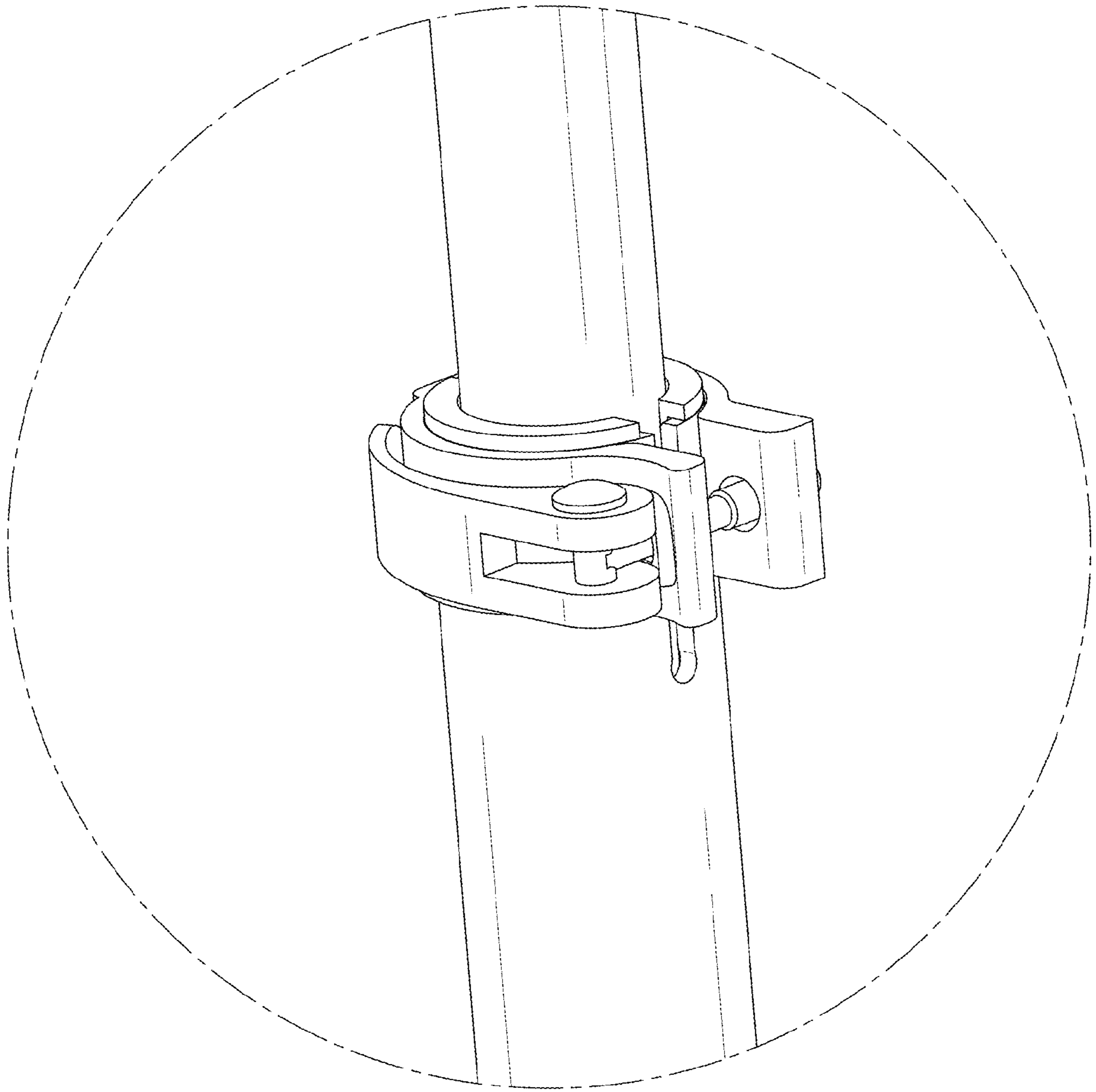

FIG. 12

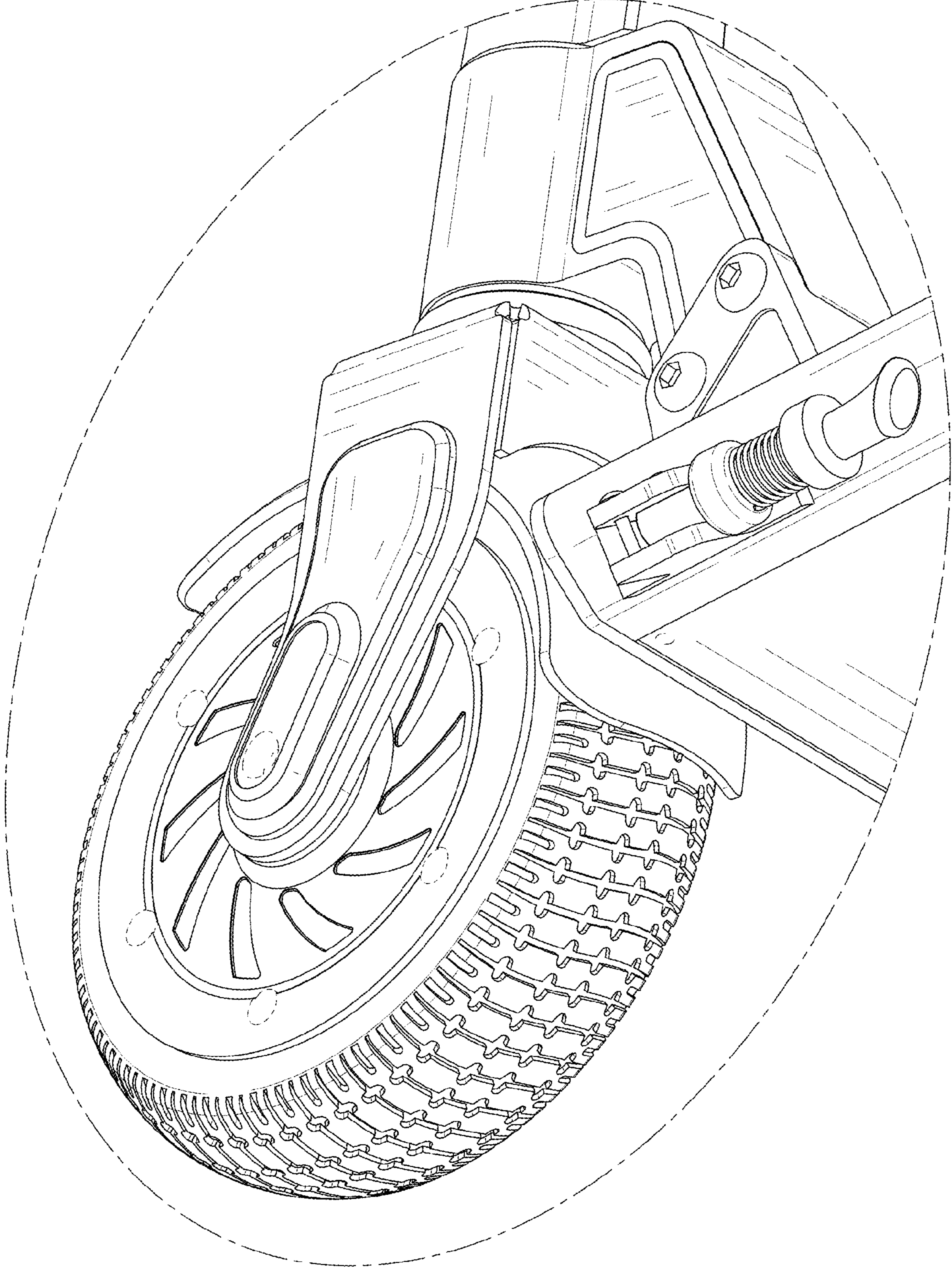

FIG. 13

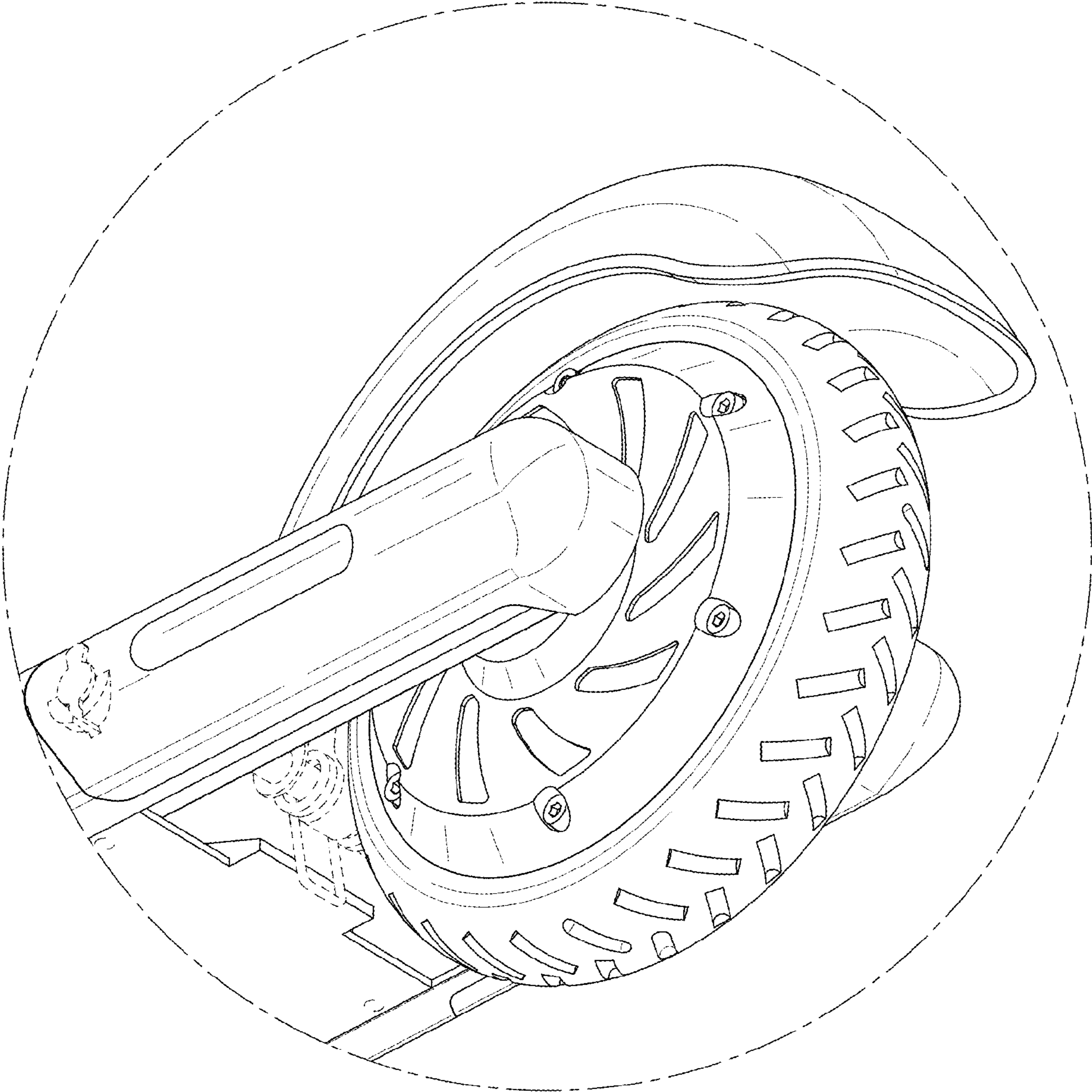

FIG. 14