

US00D942980S

(12) **United States Design Patent** (10) **Patent No.:** **US D942,980 S**
Wright et al. (45) **Date of Patent:** **** Feb. 8, 2022**

(54) **SLEEVE FOR ELECTRONIC DEVICE**
 (71) Applicant: **Catalyst Lifestyle Limited**, North Point (HK)
 (72) Inventors: **Joshua Wright**, Hong Kong (CN); **June Lai**, Hong Kong (CN)
 (73) Assignee: **Catalyst Lifestyle Limited**, Hong Kong (CN)

(**) Term: **15 Years**

(21) Appl. No.: **29/724,166**

(22) Filed: **Feb. 13, 2020**

(30) **Foreign Application Priority Data**

Oct. 31, 2019 (CN) 201930596826.2

(51) **LOC (13) Cl.** **14-02**

(52) **U.S. Cl.**
USPC **D14/440**

(58) **Field of Classification Search**
 USPC D14/440, 447, 250; 206/45.23, 320,
 206/45.2; 361/679.55; 294/25; 224/218;
 D3/294; D9/420
 CPC G06F 1/1628; G06F 1/1626; A47B 23/044
 See application file for complete search history.

(56) **References Cited**

U.S. PATENT DOCUMENTS

4,907,694 A 3/1990 Miller et al.
 D323,929 S 2/1992 Hodson
 D348,268 S 6/1994 Chambers
 D357,919 S 5/1995 Tsui
 D362,542 S 9/1995 Richards et al.
 D375,197 S 11/1996 Laherty
 D377,788 S 2/1997 Carlson
 D393,148 S 4/1998 Petruzzi
 5,740,624 A 4/1998 Baseley
 D399,604 S 10/1998 Wolff
 D405,256 S 2/1999 Chacon et al.
 D420,006 S 2/2000 Tonino
 D423,509 S 4/2000 Park

6,068,119 A 5/2000 Derr et al.
 D427,583 S 7/2000 Kazama
 6,305,538 B1 10/2001 Jackson
 D450,313 S 11/2001 Koinuma
 D467,799 S * 12/2002 Persson D9/420
 D468,296 S 1/2003 Graceffa
 D475,696 S 6/2003 Hussaini et al.
 D478,721 S 8/2003 Anderton
 6,659,274 B2 12/2003 Enners
 D496,031 S 9/2004 Ma et al.
 6,817,470 B1 11/2004 Goldberg
 D503,851 S 4/2005 Landow
 D531,618 S 11/2006 Kennemer et al.
 D558,973 S 1/2008 Hussaini et al.
 7,347,325 B2 3/2008 O'Neill et al.
 D569,608 S 5/2008 Rowe
 D570,597 S 6/2008 Klein
 D572,206 S 7/2008 Ikeda et al.
 D592,400 S 5/2009 Nelson
 D594,659 S 6/2009 Lown et al.
 D595,952 S 7/2009 Nussberger
 D596,393 S 7/2009 Leung et al.
 D599,546 S 9/2009 Lown et al.
 D600,913 S 9/2009 Kalbach
 7,584,841 B2 9/2009 Chan et al.
 D601,366 S 10/2009 Barabas et al.
 D604,040 S 11/2009 Fleming
 D605,175 S 12/2009 Maruska et al.
 D614,402 S 4/2010 Lown et al.
 D618,229 S 6/2010 de Jong et al.
 D620,259 S 7/2010 Fahrendorff et al.
 7,775,354 B2 8/2010 Latchford et al.
 D623,399 S 9/2010 McSweyn
 D627,675 S 11/2010 Graham et al.
 7,855,529 B2 12/2010 Liu
 D648,980 S * 11/2011 Forti D7/363
 D666,408 S 9/2012 Neely, III
 D666,821 S 9/2012 Phillips et al.
 D666,824 S 9/2012 Phillips et al.
 D666,826 S 9/2012 Phillips et al.
 D669,272 S 10/2012 Yang et al.
 D670,497 S 11/2012 Phillips et al.
 8,399,764 B2 3/2013 Klosky
 D681,613 S 5/2013 Magness et al.
 D683,136 S 5/2013 Wilson et al.
 D692,664 S 11/2013 Rashid
 8,644,011 B2 2/2014 Parkinson
 D707,041 S 6/2014 Park et al.
 D709,869 S 7/2014 Witter et al.
 D711,866 S 8/2014 Kawata
 D714,296 S 9/2014 Fujioka
 8,831,538 B2 9/2014 Yuen
 D718,750 S 12/2014 Young et al.

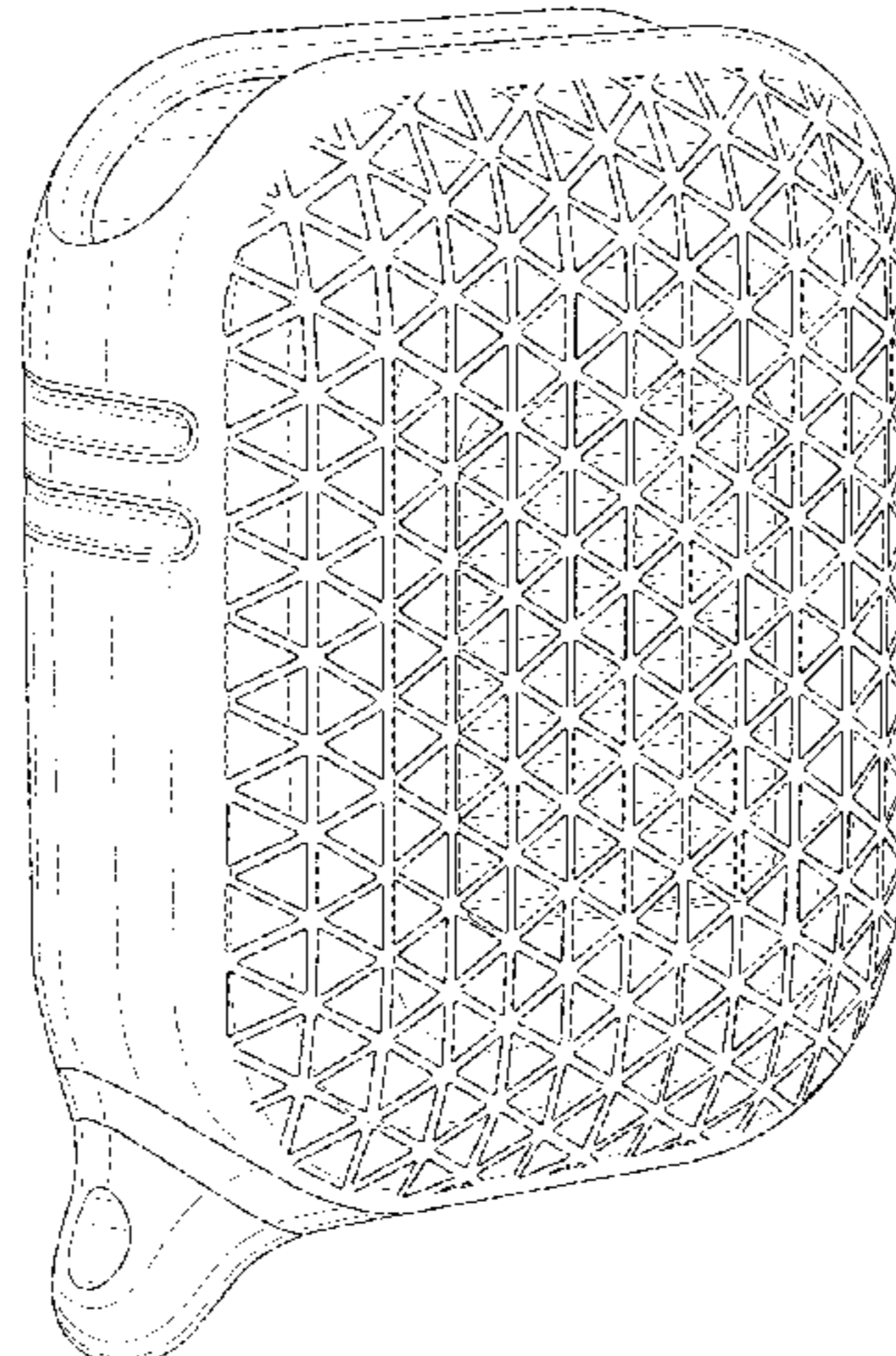

US D942,980 S

Page 2

D720,096 S 12/2014 McDougall
D720,718 S 1/2015 Stevinson
8,961,015 B1 2/2015 Bihn
D731,178 S * 6/2015 Gorouvein D3/265
D732,681 S 6/2015 Matsuura
D733,696 S 7/2015 Burgett et al.
9,090,385 B2 7/2015 Blagojevic
D735,991 S 8/2015 Brennan et al.
D740,653 S 10/2015 Akana et al.
D751,558 S 3/2016 Lee
D764,476 S 8/2016 Gleason, III et al.
D766,905 S 9/2016 Lee
D768,605 S 10/2016 Wong et al.
D769,879 S 10/2016 Kim
D775,818 S * 1/2017 Ingraham D3/218
D780,740 S 3/2017 Kim
D781,295 S 3/2017 Tur
D790,512 S 6/2017 Lee
D794,617 S 8/2017 Wright et al.
D794,618 S 8/2017 Wright et al.
9,733,054 B2 8/2017 Blagojevic
D800,700 S 10/2017 Bergman
D805,502 S 12/2017 Zhuang
D806,082 S 12/2017 Armstrong et al.
D806,388 S 1/2018 Akana et al.
D812,065 S 3/2018 Shim
D836,478 S 12/2018 Wright et al.
D838,265 S 1/2019 Wright et al.
D838,480 S * 1/2019 Son D3/294
D838,723 S 1/2019 Wang
D841,580 S * 2/2019 Bao D13/108
D841,581 S * 2/2019 Bonahoom D13/108
D846,264 S 4/2019 Wu
D847,807 S 5/2019 Wright et al.
D848,013 S 5/2019 Fuhner et al.
D849,401 S * 5/2019 Akana D3/274
D852,372 S 6/2019 Fuhner et al.
D854,022 S 7/2019 Chen
D856,310 S 8/2019 Lu
D862,425 S * 10/2019 Yan D14/223
D862,435 S * 10/2019 Kwak D14/240
D864,110 S * 10/2019 Yoshimura D13/108
D864,971 S * 10/2019 Lee D14/440
D868,453 S 12/2019 Lee et al.
D868,465 S * 12/2019 Lee D3/269
D869,147 S * 12/2019 Lian D3/201
D869,161 S 12/2019 Zhong
D869,163 S * 12/2019 Maguire D3/301
D869,675 S 12/2019 Hitscherich et al.
D870,037 S * 12/2019 Lee D13/107
D870,451 S * 12/2019 Birger D3/201
D872,094 S 1/2020 Wright et al.
D872,468 S * 1/2020 Lee D3/269
D872,469 S * 1/2020 Lee D3/269
D872,723 S 1/2020 Lee et al.
D872,724 S 1/2020 Lee et al.
D873,217 S * 1/2020 Zhang D13/108
D874,826 S * 2/2020 Zhang D3/303
D878,045 S * 3/2020 Akana D3/274
D878,754 S 3/2020 Lee et al.
D881,179 S * 4/2020 Wright D14/250
D881,181 S 4/2020 Wright et al.
D881,566 S 4/2020 Lee et al.
D881,572 S * 4/2020 Wang D3/294
D881,867 S 4/2020 Lee et al.
D882,259 S 4/2020 Liu
D886,453 S 6/2020 Wright et al.
D887,401 S 6/2020 Wright et al.
D888,036 S 6/2020 Wright et al.
D888,039 S * 6/2020 Wright D14/250
D888,040 S * 6/2020 Wright D14/250
D888,041 S * 6/2020 Wright D14/250
D888,042 S * 6/2020 Wright D14/250
D888,043 S * 6/2020 Wright D14/250
D888,408 S 6/2020 Lee et al.
D891,771 S 8/2020 Lee et al.
D892,497 S * 8/2020 Wright D3/294
D892,498 S * 8/2020 Wright D3/294
D892,499 S 8/2020 Wright et al.

D893,184 S 8/2020 Liu
D897,678 S 10/2020 Koh
D897,997 S 10/2020 Zhang
D903,316 S 12/2020 Kwak et al.
D907,009 S 1/2021 Akana et al.
D911,711 S * 3/2021 Feng D3/294
11,039,523 B2 * 6/2021 Wang H05B 47/12
D926,470 S * 8/2021 Luo D3/294
D927,181 S * 8/2021 Jung D3/294
D928,165 S * 8/2021 Li D14/440
D931,268 S * 9/2021 Wright D14/250
2007/0261978 A1 11/2007 Sanderson
2011/0017620 A1 1/2011 Latchiford et al.
2015/0014367 A1 1/2015 VanSyckel
2015/0195938 A1 7/2015 Witter et al.
2016/0240945 A1 8/2016 Lee et al.
2020/0100573 A1 * 4/2020 Ekelund A45C 11/00

FOREIGN PATENT DOCUMENTS

CN	3160446 S	9/2000
CN	301100826 S	1/2010
CN	301206950 S	5/2010
CN	301304263 S	8/2010
CN	301908776 S	5/2012
CN	302075062 S	9/2012
CN	302246979 S	12/2012
CN	302302598 S	1/2013
CN	302706977 S	1/2014
CN	302822402 S	5/2014
CN	303054765 S	12/2014
CN	303092548 S	2/2015
CN	304021713 S	2/2017
CN	304239640 S	8/2017
CN	304317772 S	10/2017
CN	304335071 S	10/2017
CN	304335072 S	10/2017
CN	304342633 S	11/2017
CN	304344793 S	11/2017
CN	304351321 S	11/2017
CN	304362692 S	11/2017
CN	304372544 S	11/2017
CN	206744792 U	12/2017
CN	304382968 S	12/2017
CN	304382972 S	12/2017
CN	304469866 S	1/2018
CN	304477001 S	1/2018
CN	304493923 S	2/2018
CN	304499444 S	2/2018
CN	304501780 S	2/2018
CN	304504641 S	2/2018
CN	304539055 S	3/2018
CN	304983166 S	1/2019
CN	208581338 U	3/2019
CN	208939608 U	6/2019
DE	202018105634 U1	11/2018
DE	202018105634 U1	12/2018
JP	D1574277	3/2017
KR	300355285	6/2004
KR	300384969	6/2005
KR	20130028536 A	3/2013
KR	200488427 Y1	1/2019

OTHER PUBLICATIONS

Office Action dated Jun. 24, 2020 pertaining to Design U.S. Appl. No. 29/677,855, filed Jan. 24, 2019, 28 pgs.
Kim1991tae. "AirPod Case Catalyst." Naver, Aug. 9, 2017. Web. <https://blog.naver.com/kim1991tae/221070237784>.
Office Action dated May 7, 2020 pertaining to Design U.S. Appl. No. 29/709,817, filed Oct. 17, 2019, 18 pgs.
Office Action dated Apr. 29, 2020 pertaining to U.S. Appl. No. 16/458,476, filed Jul. 1, 2019, 11 pgs.
Breville Smart Oven Review, publication date Sep. 10, 2013, [online][site visited Apr. 30, 2020] URL: <https://www.cnet.com/reviews/breville-smart-oven-review/> (Year: 2013).

Linear DNT Garage Door Remote Control, earliest photo verified date on webarchive Jul. 23, 2016, [online][site visited Apr. 30, 2020] URL: <https://dooropenersandmore.com/linear-dnt00026-mini-remote-control> (Year: 2016).

Notice of Allowance and Fee(s) Due dated Apr. 9, 2020 pertaining to U.S. Appl. No. 29/665,170, filed Oct. 1, 2018, 21 pgs.

This AirPods Accessory is strangely awesome—Catalyst AirPods Case, publication date Apr. 7, 2017, [online][site visited Sep. 9, 2019] URL: <https://www.cnet.com/news/coming-soon-a-waterproof-case-for-your-airpods-case/> (Year: 2017).

This glow-in-the-dark, waterproof AirPods case—Catalyst AirPods Case, publication date Apr. 14, 2017, [online][site visited Sep. 9, 2019] URL: <https://www.theverge.com/circuitbreaker/2017/4/14/15306100/catalyst-case-airpods-sale-glow-in-the-dark> (Year: 2017). Kim1991tae. “AirPod Case Catalyst.” Naver, Aug. 9, 2017. Web. <http://blog.naver.com/kim1991tae/221070237784>.

* cited by examiner

Primary Examiner — Cynthia R Underwood
(74) *Attorney, Agent, or Firm* — Dinsmore & Shohl LLP

(57) **CLAIM**

The ornamental design for a sleeve for electronic device, as shown and described.

DESCRIPTION

FIG. 1 is a perspective view including the front, top, and side of an embodiment of a sleeve for electronic device;

FIG. 2 is a perspective view including the rear, top, and side of the sleeve for electronic device of FIG. 1;

FIG. 3 is a front elevation view of the sleeve for electronic device of FIG. 1;

FIG. 4 is a rear elevation view of the sleeve for electronic device of FIG. 1;

FIG. 5 is a side elevation of the sleeve for electronic device of FIG. 1;

FIG. 6 is an opposite side elevation view of the sleeve for electronic device of FIG. 1;

FIG. 7 is a top plan view of the sleeve for electronic device of FIG. 1;

FIG. 8 is a bottom plan view of the sleeve for electronic device of FIG. 1;

FIG. 9 is a perspective view including the front, top, and side of an embodiment of a sleeve for electronic device;

FIG. 10 is a perspective view including the rear, top, and side of the sleeve for electronic device of FIG. 9;

FIG. 11 is a front elevation view of the sleeve for electronic device of FIG. 9;

FIG. 12 is a rear elevation view of the sleeve for electronic device of FIG. 9;

FIG. 13 is a side elevation of the sleeve for electronic device of FIG. 9;

FIG. 14 is an opposite side elevation view of the sleeve for electronic device of FIG. 9;

FIG. 15 is a top plan view of the sleeve for electronic device of FIG. 9;

FIG. 16 is a bottom plan view of the sleeve for electronic device of FIG. 9;

FIG. 17 is a perspective view including the front, top, and side of an embodiment of a sleeve for electronic device;

FIG. 18 is a perspective view including the rear, top, and side of the sleeve for electronic device of FIG. 17;

FIG. 19 is a front elevation view of the sleeve for electronic device of FIG. 17;

FIG. 20 is a rear elevation view of the sleeve for electronic device of FIG. 17;

FIG. 21 is a side elevation of the sleeve for electronic device of FIG. 17;

FIG. 22 is an opposite side elevation view of the sleeve for electronic device of FIG. 17;

FIG. 23 is a top plan view of the sleeve for electronic device of FIG. 17;

FIG. 24 is a bottom plan view of the sleeve for electronic device of FIG. 17;

FIG. 25 is a perspective view including the front, top, and side of an embodiment of a sleeve for electronic device;

FIG. 26 is a perspective view including the rear, top, and side of the sleeve for electronic device of FIG. 25;

FIG. 27 is a front elevation view of the sleeve for electronic device of FIG. 25;

FIG. 28 is a rear elevation view of the sleeve for electronic device of FIG. 25;

FIG. 29 is a side elevation of the sleeve for electronic device of FIG. 25;

FIG. 30 is an opposite side elevation view of the sleeve for electronic device of FIG. 25;

FIG. 31 is a top plan view of the sleeve for electronic device of FIG. 25;

FIG. 32 is a bottom plan view of the sleeve for electronic device of FIG. 25;

FIG. 33 is a perspective view including the front, top, and side of an embodiment of a sleeve for electronic device;

FIG. 34 is a perspective view including the rear, top, and side of the sleeve for electronic device of FIG. 33;

FIG. 35 is a front elevation view of the sleeve for electronic device of FIG. 33;

FIG. 36 is a rear elevation view of the sleeve for electronic device of FIG. 33;

FIG. 37 is a side elevation of the sleeve for electronic device of FIG. 33;

FIG. 38 is an opposite side elevation view of the sleeve for electronic device of FIG. 33;

FIG. 39 is a top plan view of the sleeve for electronic device of FIG. 33;

FIG. 40 is a bottom plan view of the sleeve for electronic device of FIG. 33;

FIG. 41 is a perspective view including the front, top, and side of an embodiment of a sleeve for electronic device;

FIG. 42 is a perspective view including the rear, top, and side of the sleeve for electronic device of FIG. 41;

FIG. 43 is a front elevation view of the sleeve for electronic device of FIG. 41;

FIG. 44 is a rear elevation view of the sleeve for electronic device of FIG. 41;

FIG. 45 is a side elevation of the sleeve for electronic device of FIG. 41;

FIG. 46 is an opposite side elevation view of the sleeve for electronic device of FIG. 41;

FIG. 47 is a top plan view of the sleeve for electronic device of FIG. 41;

FIG. 48 is a bottom plan view of the sleeve for electronic device of FIG. 41;

FIG. 49 is a perspective view including the front, top, and side of an embodiment of a sleeve for electronic device;

FIG. 50 is a perspective view including the rear, top, and side of the sleeve for electronic device of FIG. 49;

FIG. 51 is a front elevation view of the sleeve for electronic device of FIG. 49;

FIG. 52 is a rear elevation view of the sleeve for electronic device of FIG. 49;

FIG. 53 is a side elevation of the sleeve for electronic device of FIG. 49;

FIG. 54 is an opposite side elevation view of the sleeve for electronic device of FIG. 49;

FIG. 55 is a top plan view of the sleeve for electronic device of FIG. 49;

FIG. 56 is a bottom plan view of the sleeve for electronic device of FIG. 49;

FIG. 57 is a perspective view including the front, top, and side of an embodiment of a sleeve for electronic device;

FIG. 58 is a perspective view including the rear, top, and side of the sleeve for electronic device of FIG. 57;

FIG. 59 is a front elevation view of the sleeve for electronic device of FIG. 57;

FIG. 60 is a rear elevation view of the sleeve for electronic device of FIG. 57;

FIG. 61 is a side elevation of the sleeve for electronic device of FIG. 57;

FIG. 62 is an opposite side elevation view of the sleeve for electronic device of FIG. 57;

FIG. 63 is a top plan view of the sleeve for electronic device of FIG. 57;

FIG. 64 is a bottom plan view of the sleeve for electronic device of FIG. 57;

FIG. 65 is a perspective view including the front, top, and side of an embodiment of a sleeve for electronic device;

FIG. 66 is a perspective view including the rear, top, and side of the sleeve for electronic device of FIG. 65;

FIG. 67 is a front elevation view of the sleeve for electronic device of FIG. 65;

FIG. 68 is a rear elevation view of the sleeve for electronic device of FIG. 65;

FIG. 69 is a side elevation of the sleeve for electronic device of FIG. 65;

FIG. 70 is an opposite side elevation view of the sleeve for electronic device of FIG. 65;

FIG. 71 is a top plan view of the sleeve for electronic device of FIG. 65;

FIG. 72 is a bottom plan view of the sleeve for electronic device of FIG. 65;

FIG. 73 is a perspective view including the front, top, and side of an embodiment of a sleeve for electronic device;

FIG. 74 is a perspective view including the rear, top, and side of the sleeve for electronic device of FIG. 73;

FIG. 75 is a front elevation view of the sleeve for electronic device of FIG. 73;

FIG. 76 is a rear elevation view of the sleeve for electronic device of FIG. 73;

FIG. 77 is a side elevation of the sleeve for electronic device of FIG. 73;

FIG. 78 is an opposite side elevation view of the sleeve for electronic device of FIG. 73;

FIG. 79 is a top plan view of the sleeve for electronic device of FIG. 73;

FIG. 80 is a bottom plan view of the sleeve for electronic device of FIG. 73;

FIG. 81 is a perspective view including the front, top, and side of an embodiment of a sleeve for electronic device;

FIG. 82 is a perspective view including the rear, top, and side of the sleeve for electronic device of FIG. 81;

FIG. 83 is a front elevation view of the sleeve for electronic device of FIG. 81;

FIG. 84 is a rear elevation view of the sleeve for electronic device of FIG. 81;

FIG. 85 is a side elevation of the sleeve for electronic device of FIG. 81;

FIG. 86 is an opposite side elevation view of the sleeve for electronic device of FIG. 81;

FIG. 87 is a top plan view of the sleeve for electronic device of FIG. 81;

FIG. 88 is a bottom plan view of the sleeve for electronic device of FIG. 81;

FIG. 89 is a perspective view including the front, top, and side of an embodiment of a sleeve for electronic device;

FIG. 90 is a perspective view including the rear, top, and side of the sleeve for electronic device of FIG. 89;

FIG. 91 is a front elevation view of the sleeve for electronic device of FIG. 89;

FIG. 92 is a rear elevation view of the sleeve for electronic device of FIG. 89;

FIG. 93 is a side elevation of the sleeve for electronic device of FIG. 89;

FIG. 94 is an opposite side elevation view of the sleeve for electronic device of FIG. 89;

FIG. 95 is a top plan view of the sleeve for electronic device of FIG. 89;

FIG. 96 is a bottom plan view of the sleeve for electronic device of FIG. 89;

FIG. 97 is a perspective view including the front, top, and side of an embodiment of a sleeve for electronic device;

FIG. 98 is a perspective view including the rear, top, and side of the sleeve for electronic device of FIG. 97;

FIG. 99 is a front elevation view of the sleeve for electronic device of FIG. 97;

FIG. 100 is a rear elevation view of the sleeve for electronic device of FIG. 97;

FIG. 101 is a side elevation of the sleeve for electronic device of FIG. 97;

FIG. 102 is an opposite side elevation view of the sleeve for electronic device of FIG. 97;

FIG. 103 is a top plan view of the sleeve for electronic device of FIG. 97;

FIG. 104 is a bottom plan view of the sleeve for electronic device of FIG. 97;

FIG. 105 is a perspective view including the front, top, and side of an embodiment of a sleeve for electronic device;

FIG. 106 is a perspective view including the rear, top, and side of the sleeve for electronic device of FIG. 105;

FIG. 107 is a front elevation view of the sleeve for electronic device of FIG. 105;

FIG. 108 is a rear elevation view of the sleeve for electronic device of FIG. 105;

FIG. 109 is a side elevation of the sleeve for electronic device of FIG. 105;

FIG. 110 is an opposite side elevation view of the sleeve for electronic device of FIG. 105;

FIG. 111 is a top plan view of the sleeve for electronic device of FIG. 105; and,

FIG. 112 is a bottom plan view of the sleeve for electronic device of FIG. 105.

The broken lines depict environment that form no part of the claim.

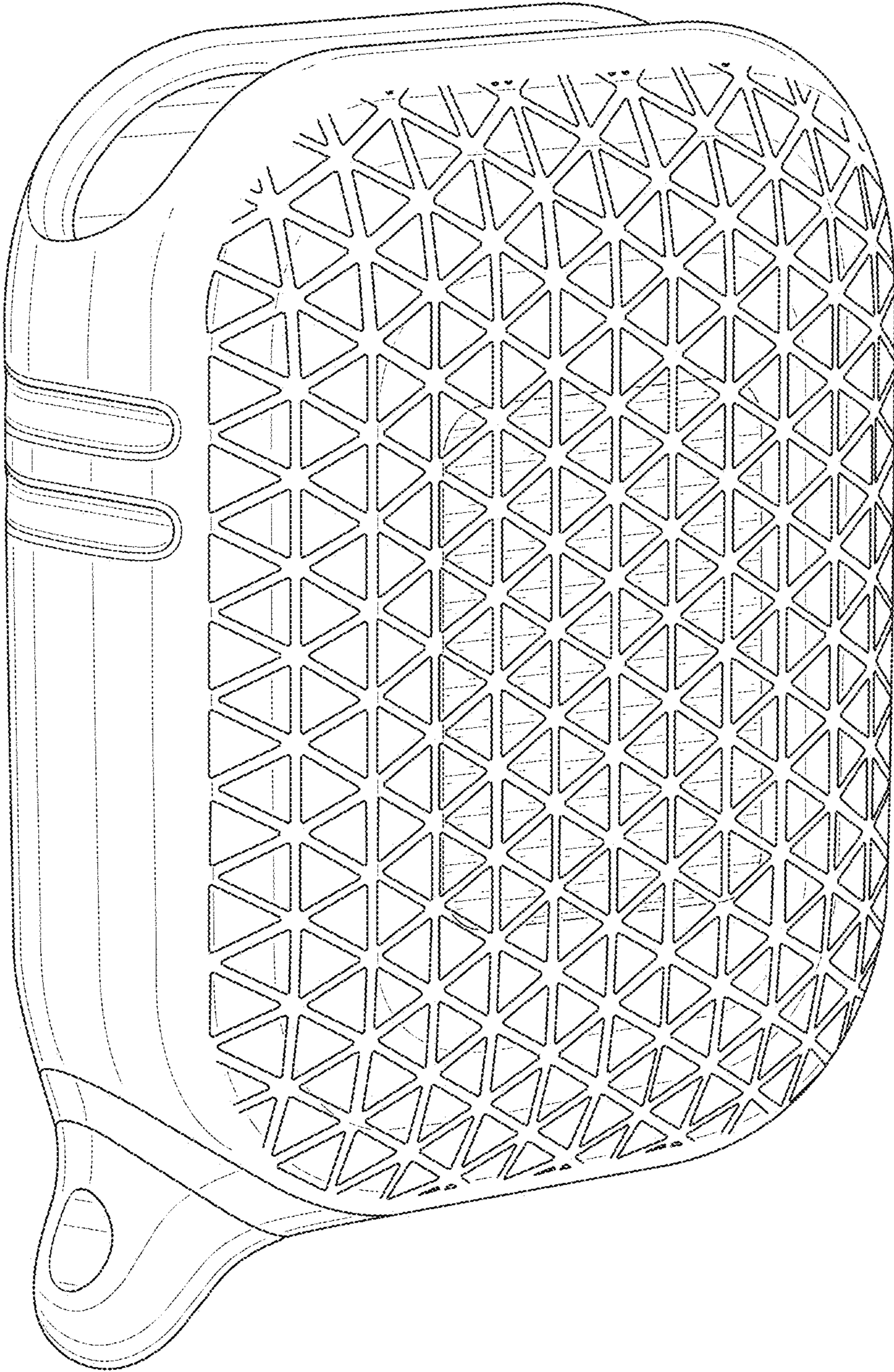

FIG. 1

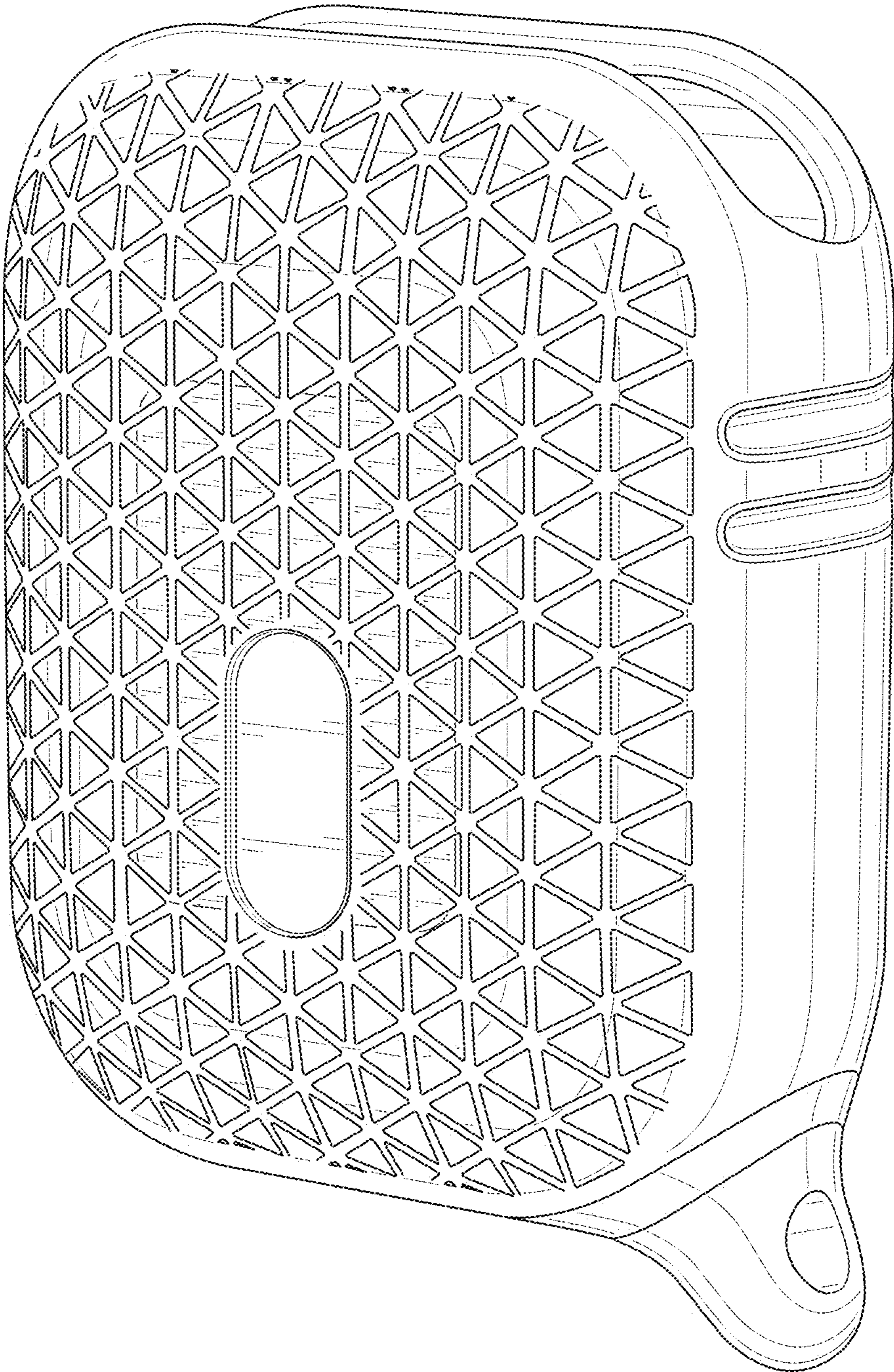

FIG. 2

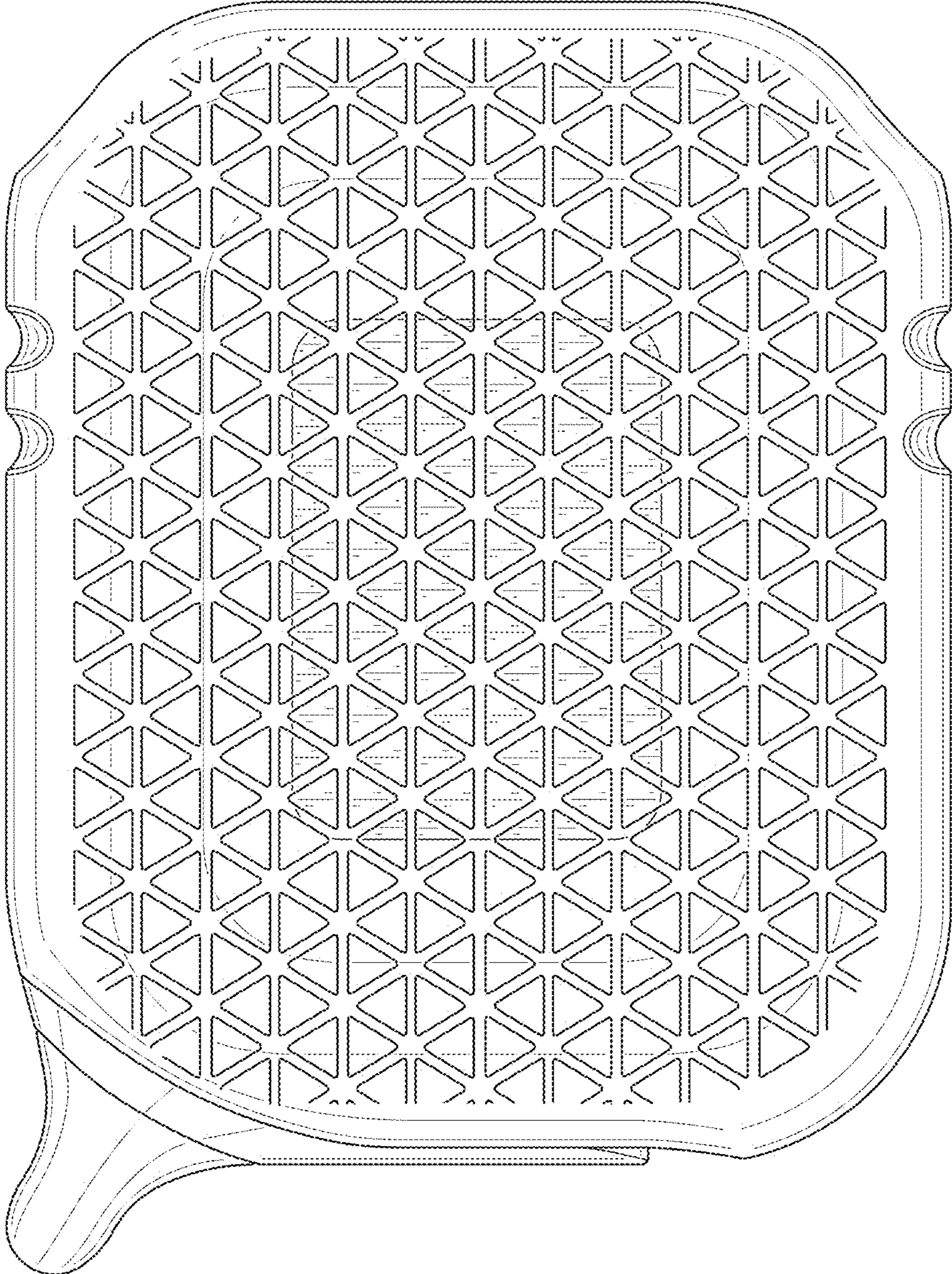

FIG. 3

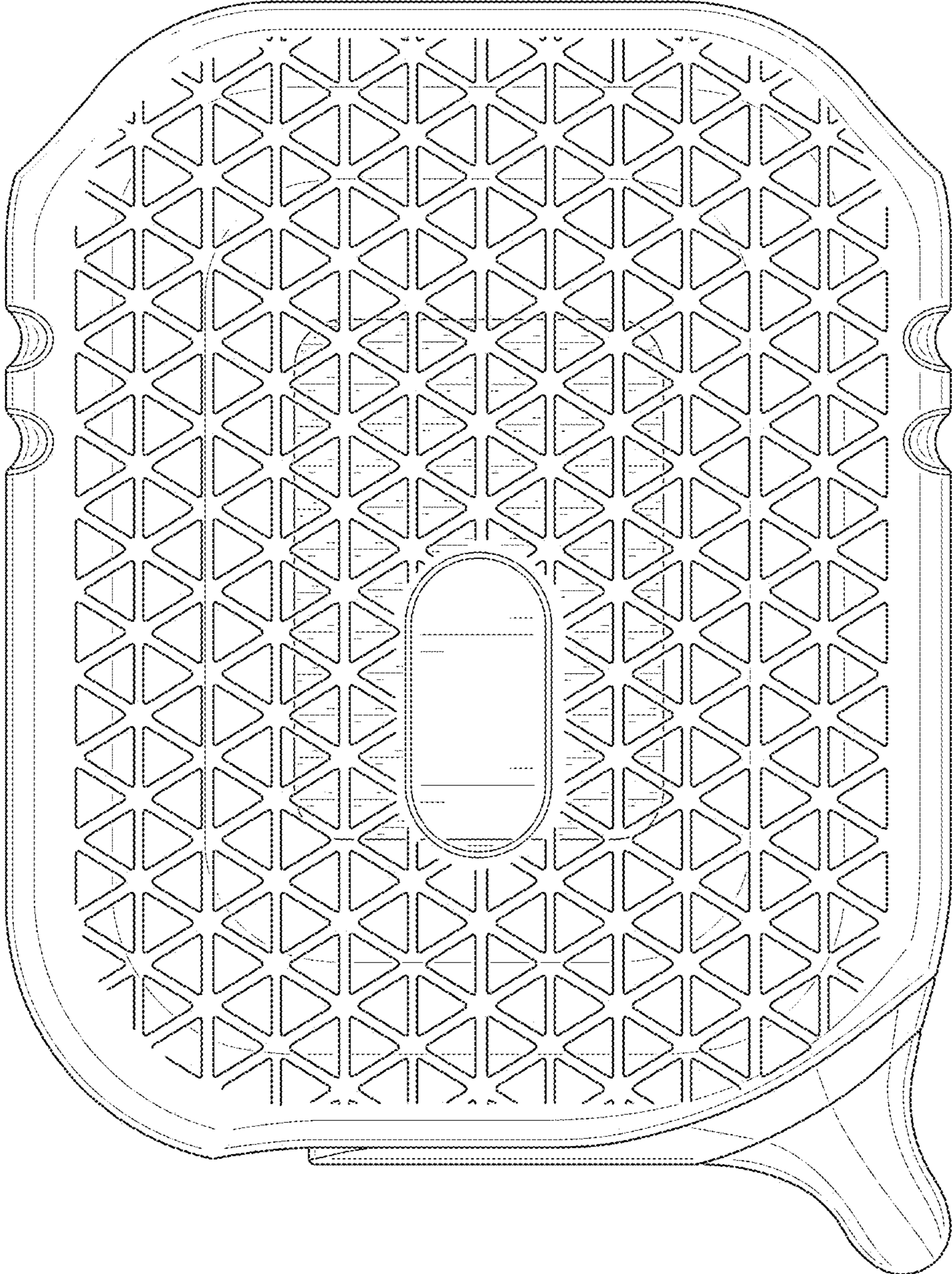

FIG. 4

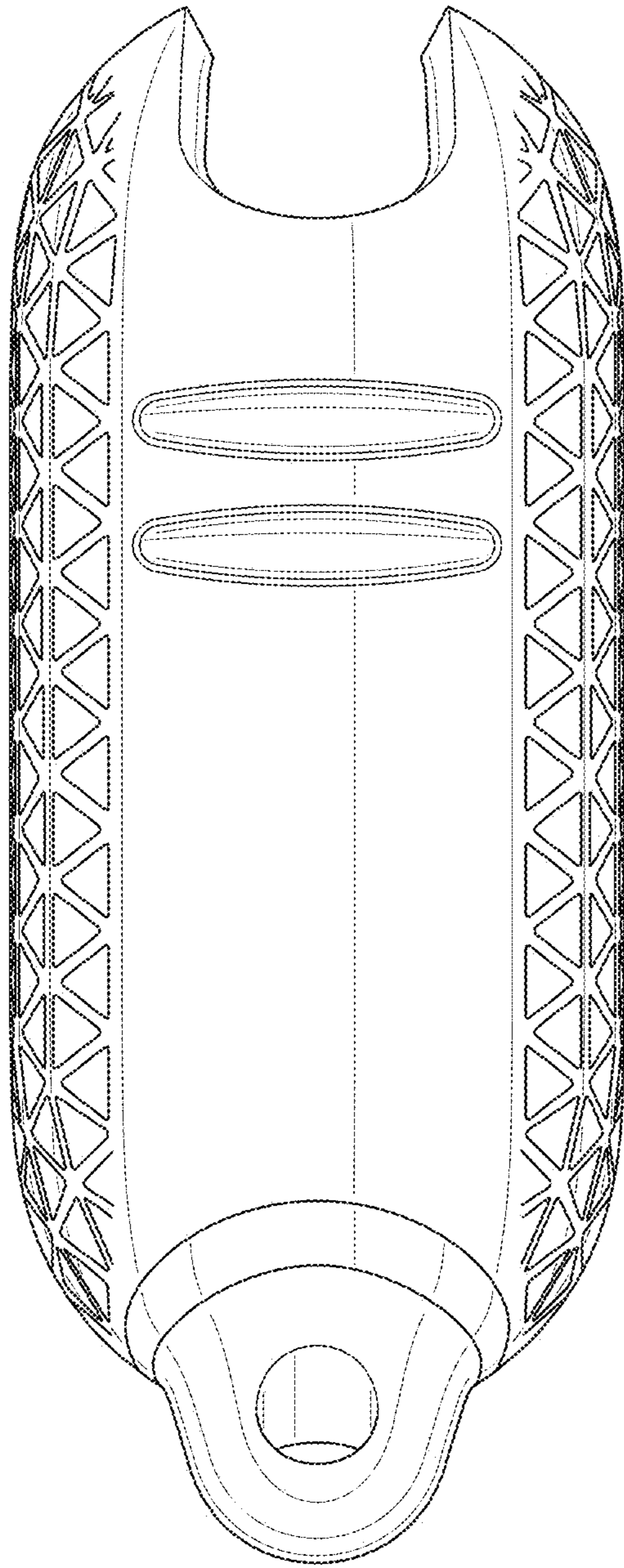

FIG. 5

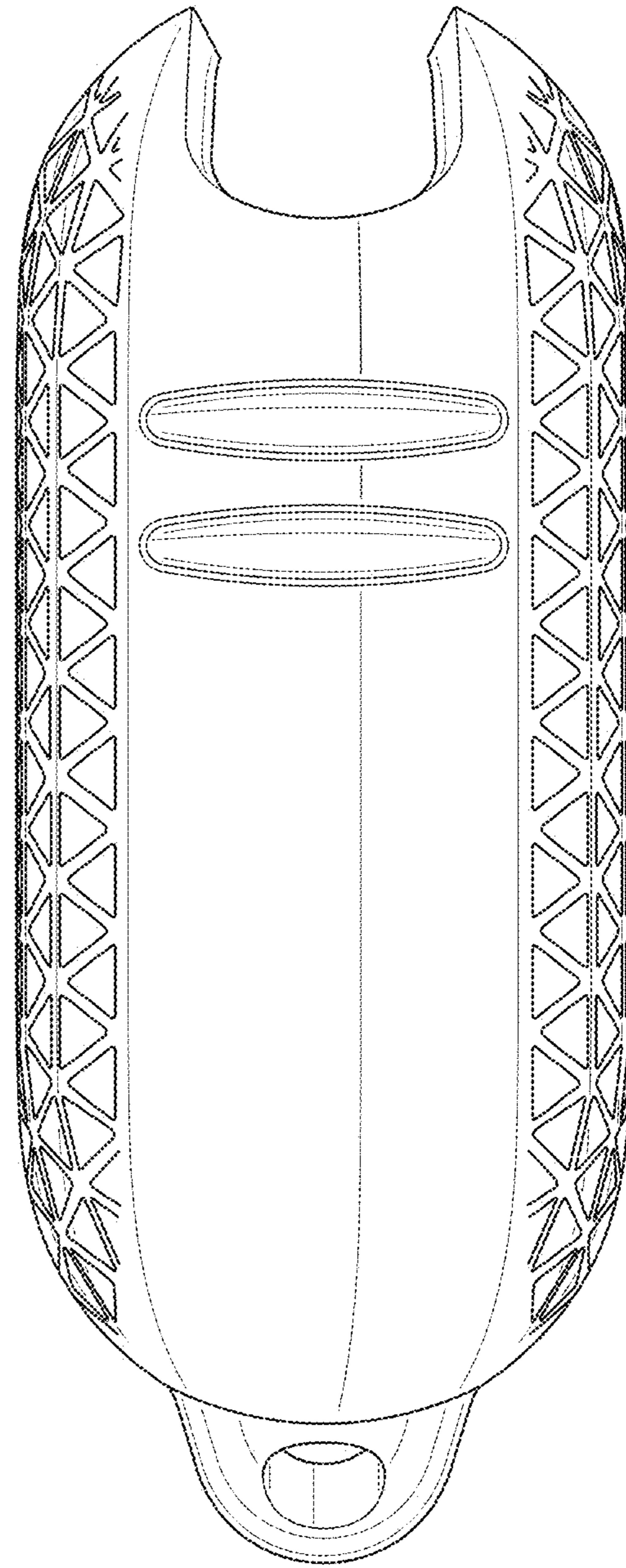

FIG. 6

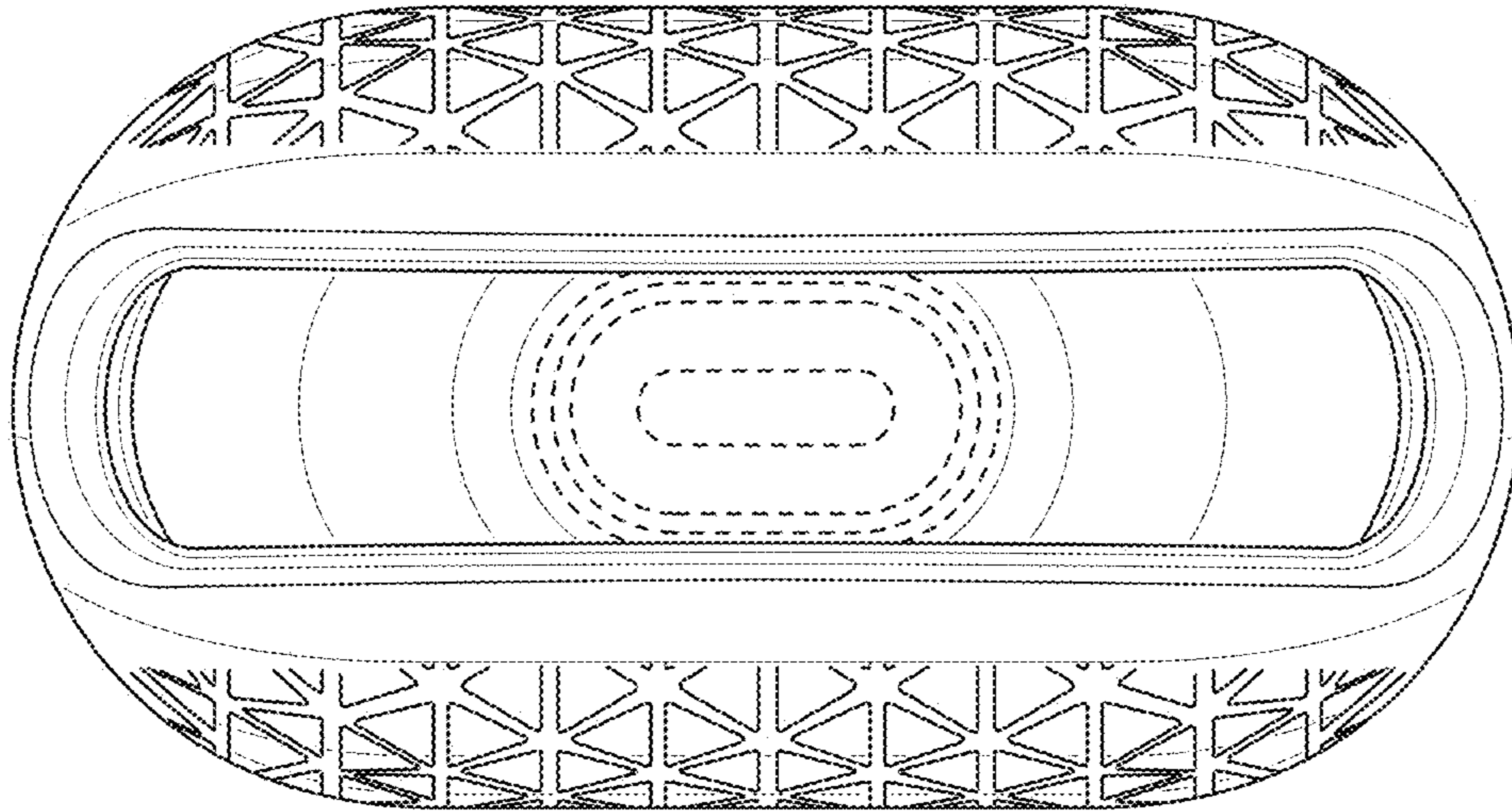

FIG. 7

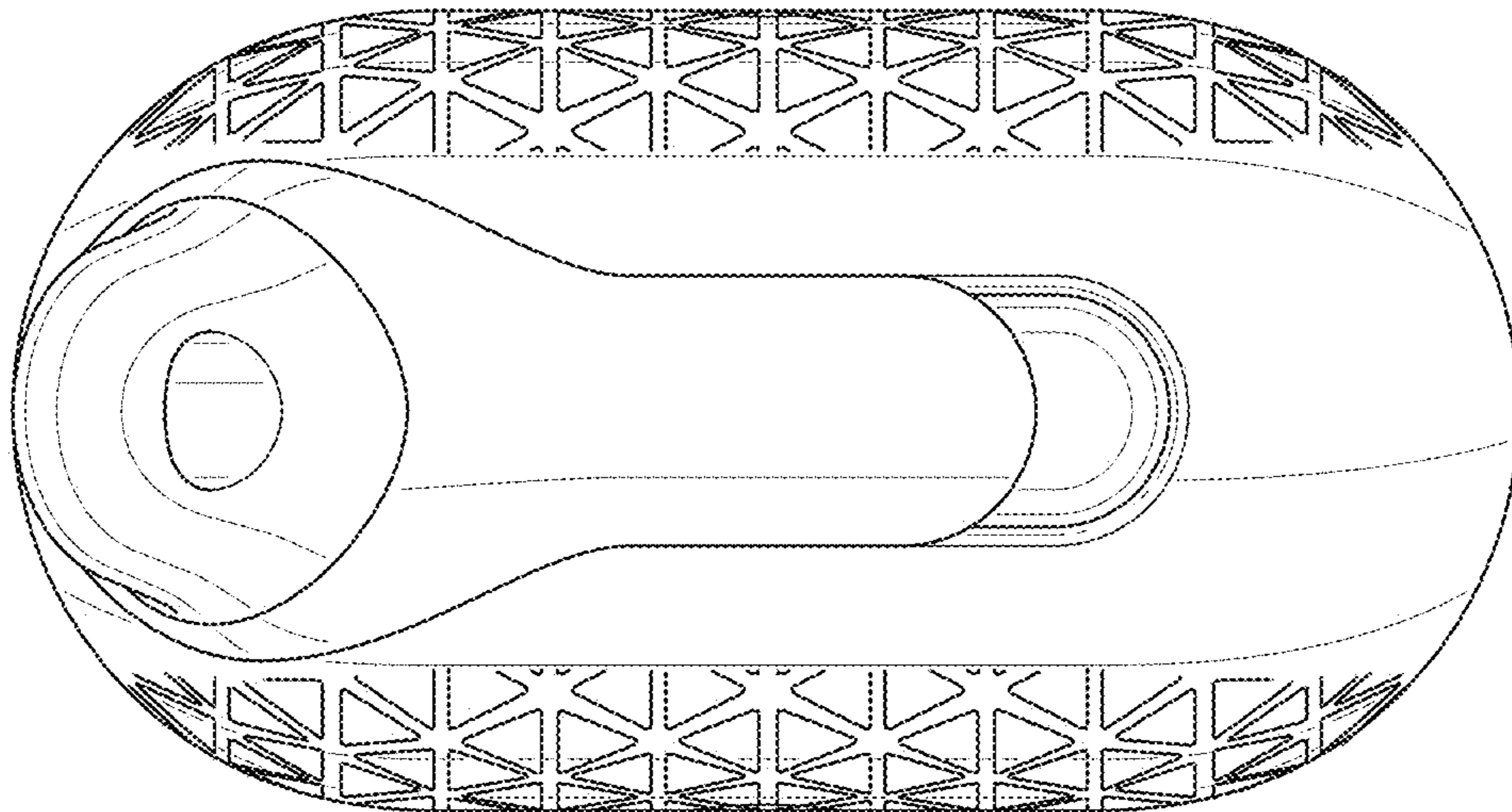

FIG. 8

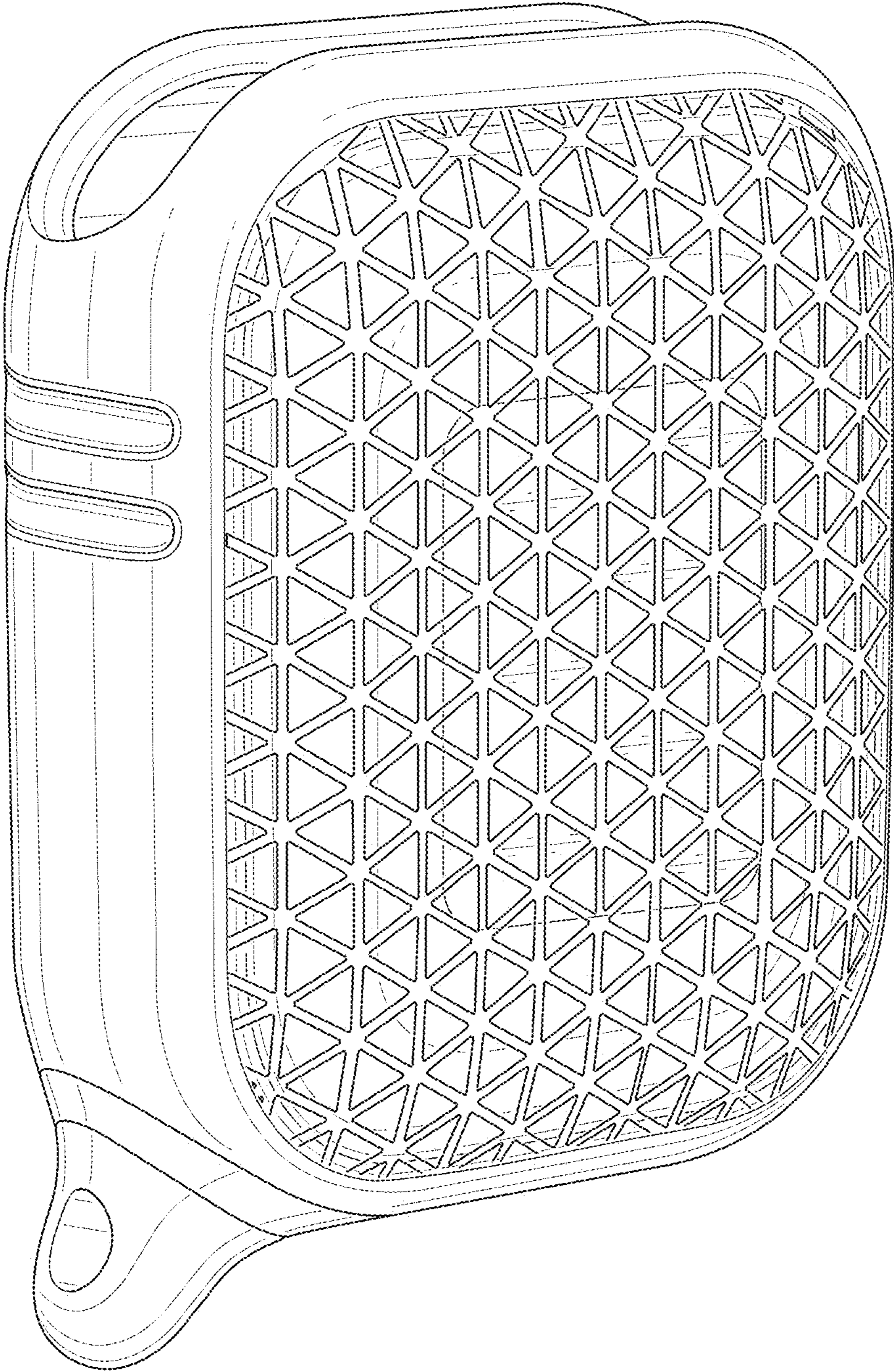

FIG. 9

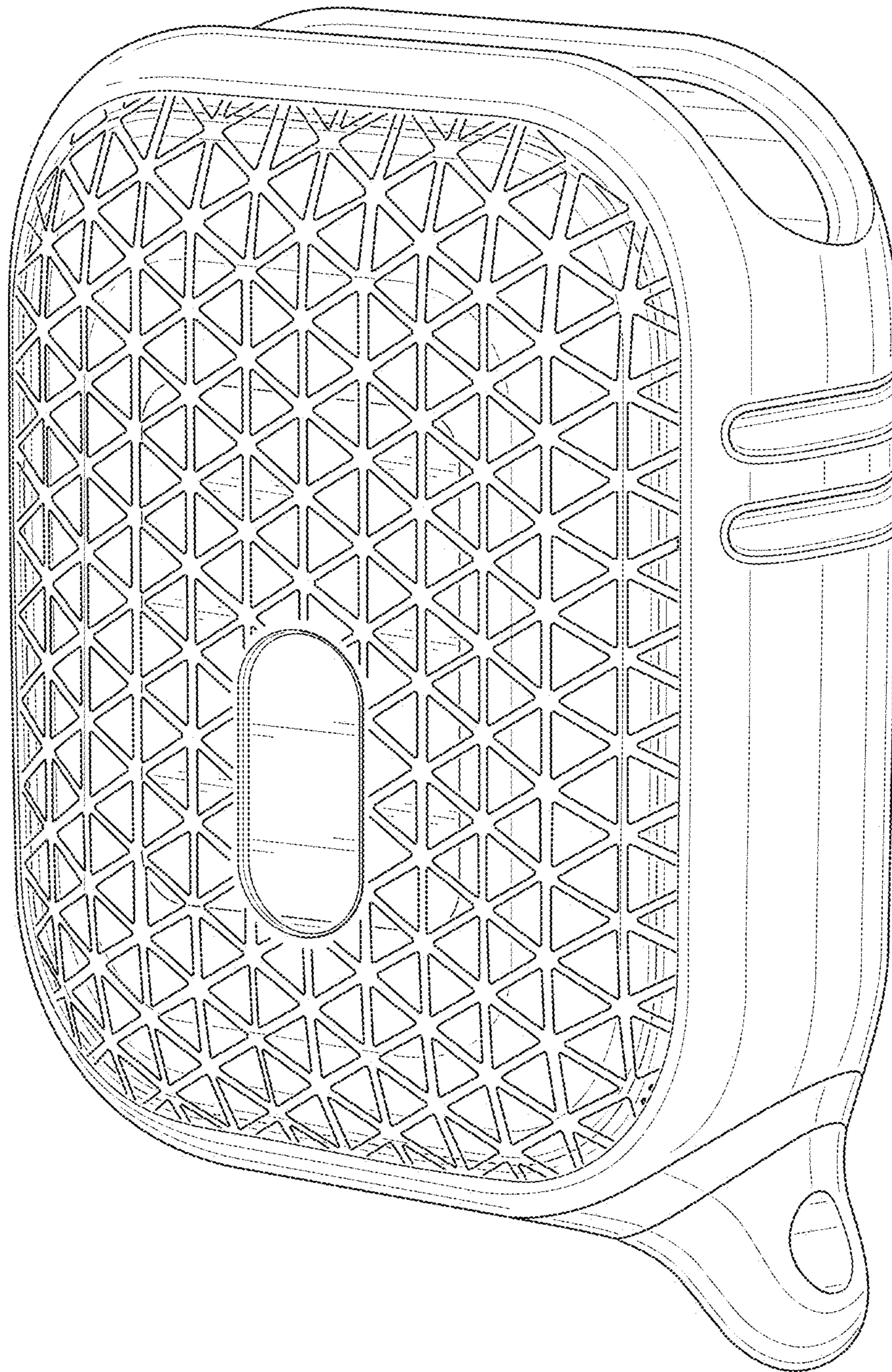

FIG. 10

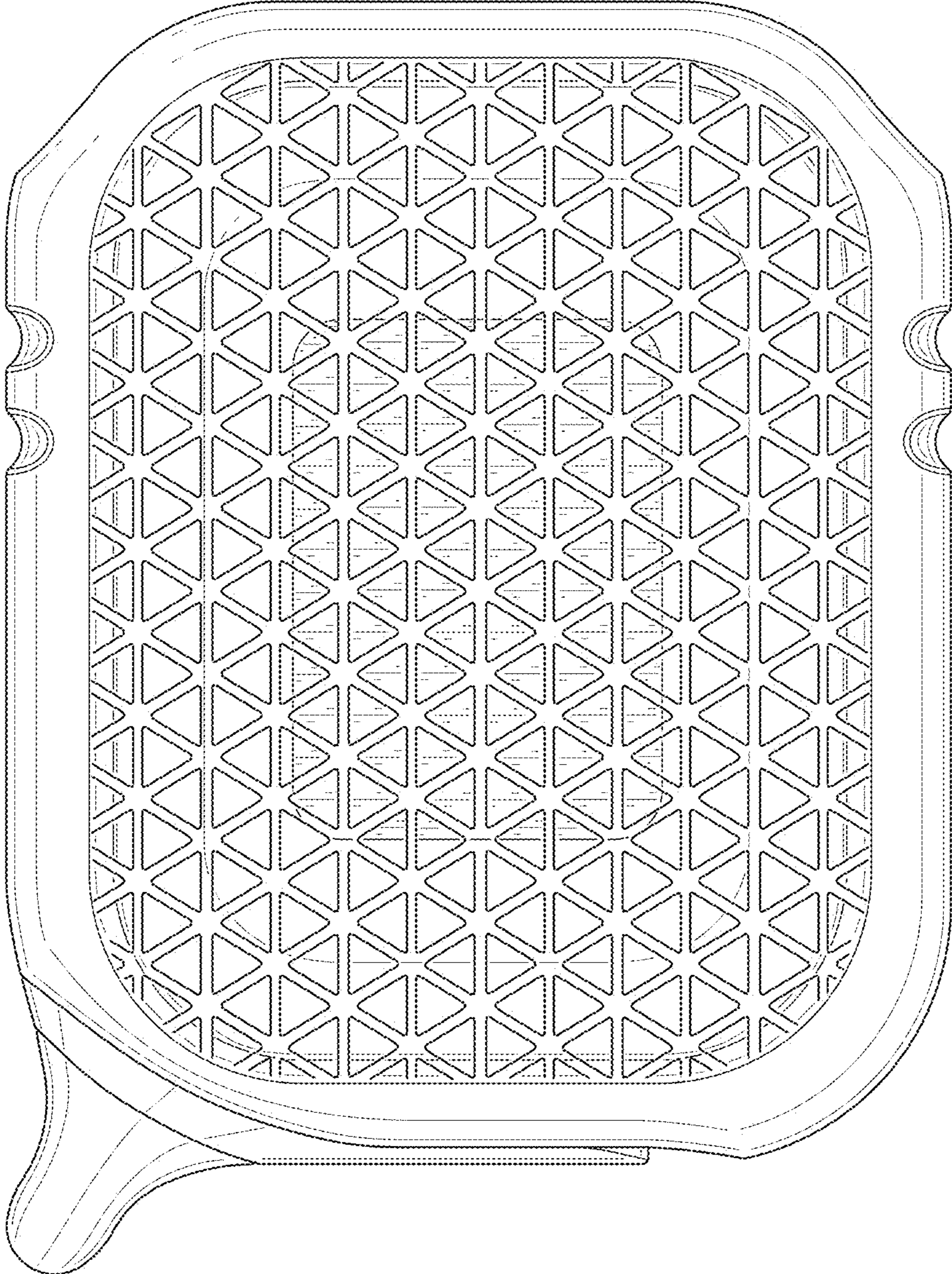

FIG. 11

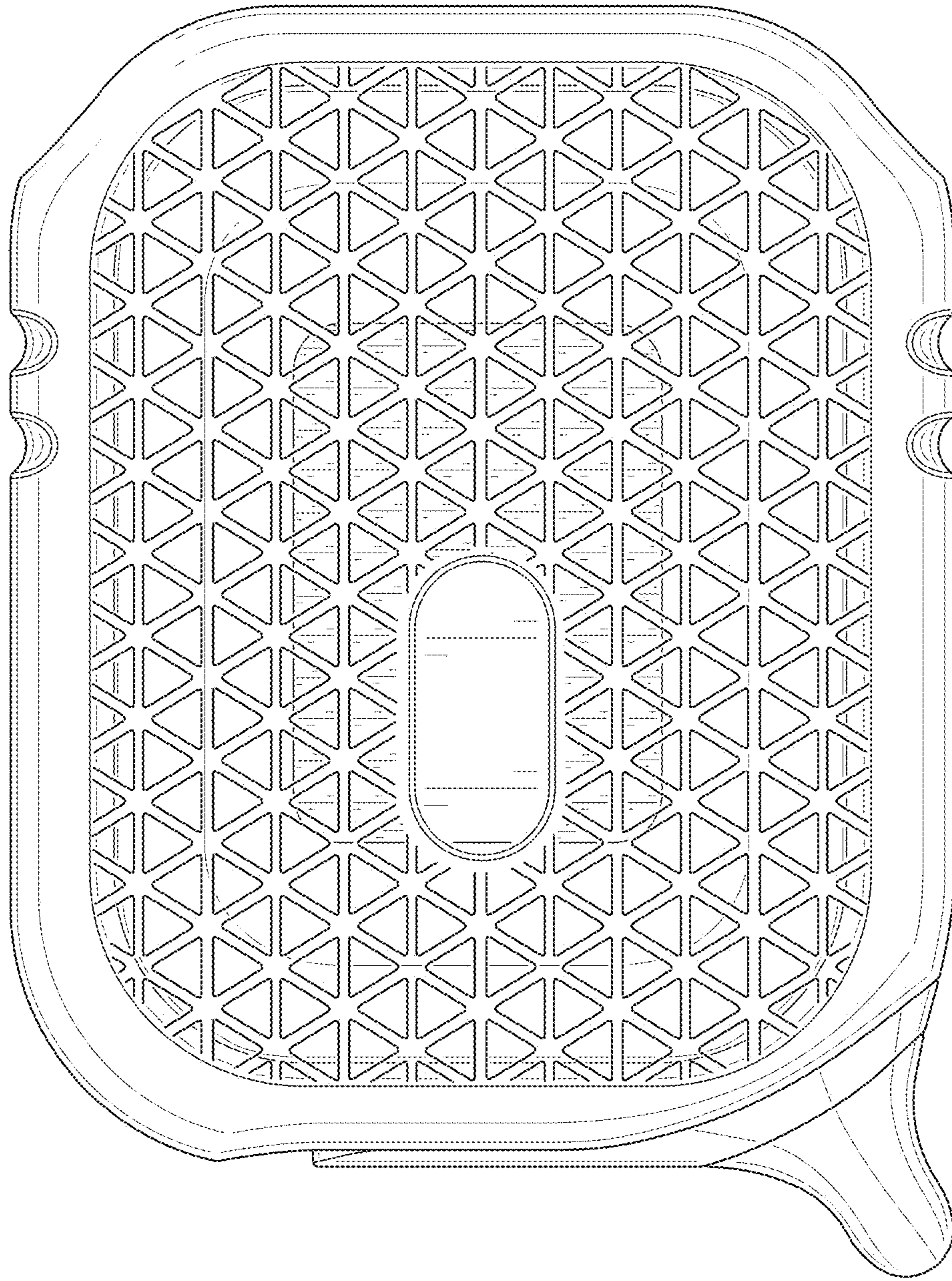

FIG. 12

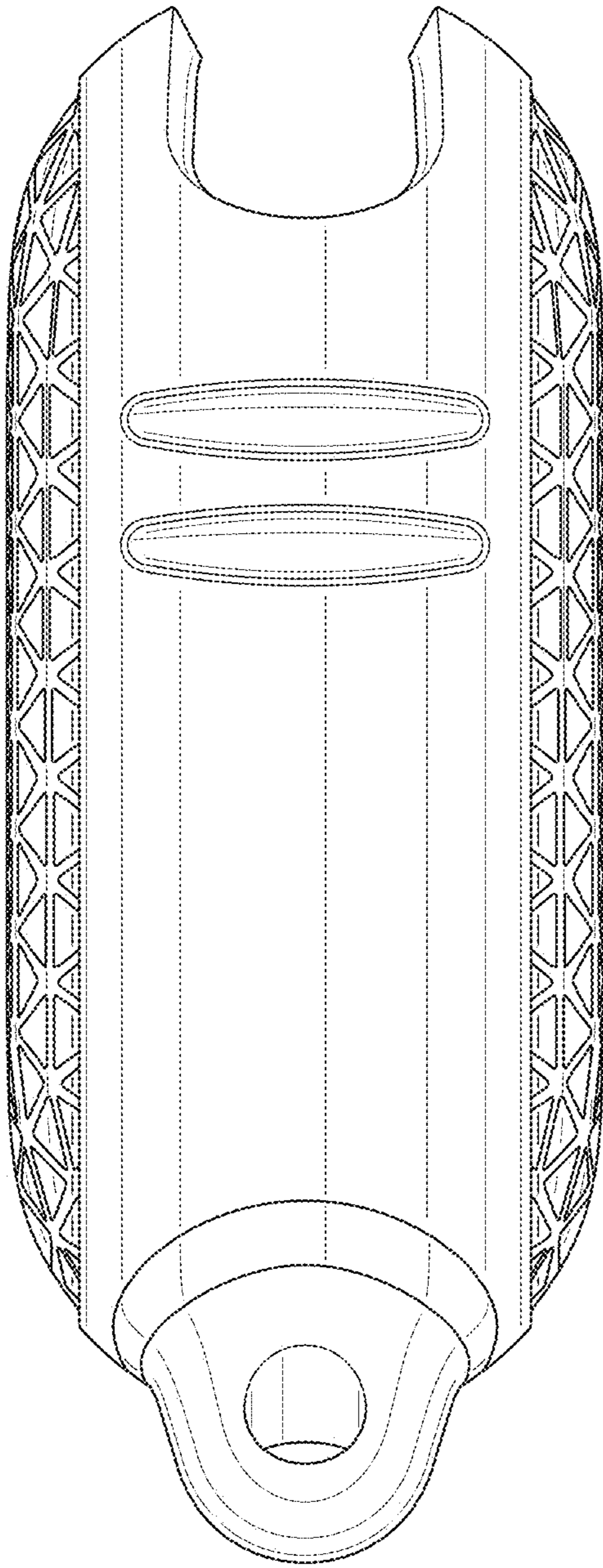

FIG. 13

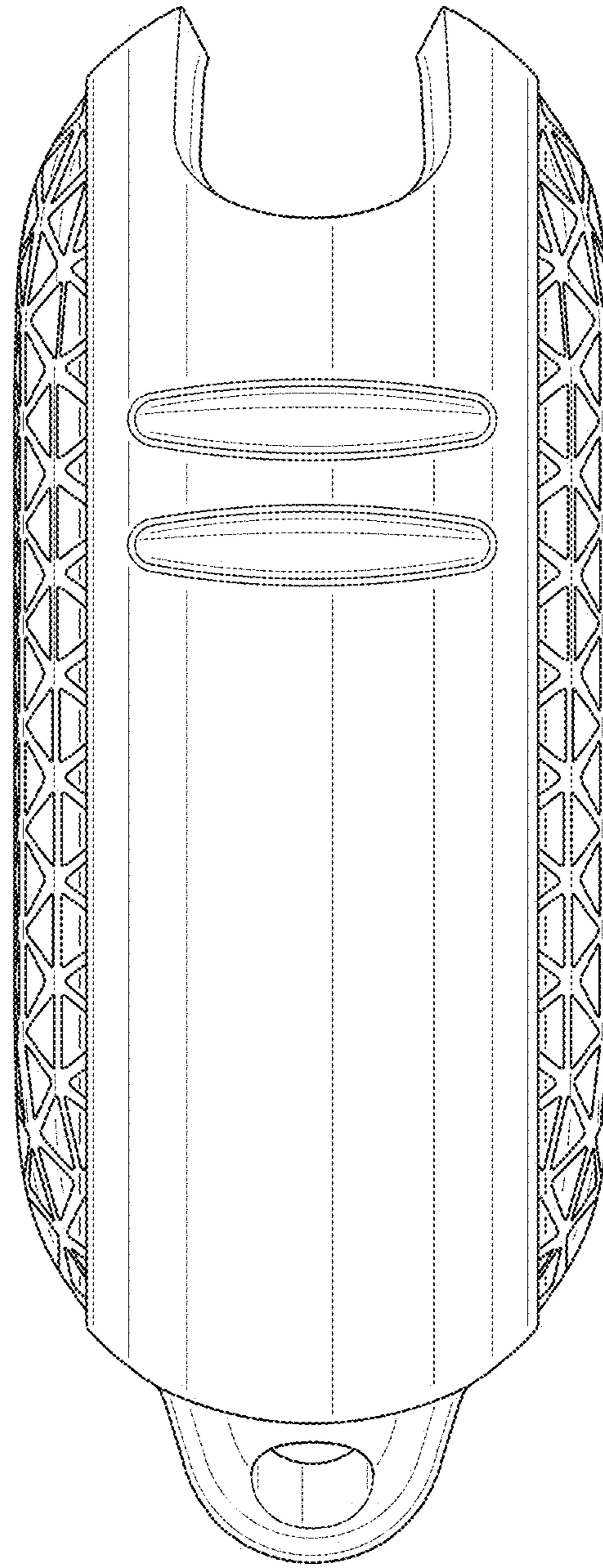

FIG. 14

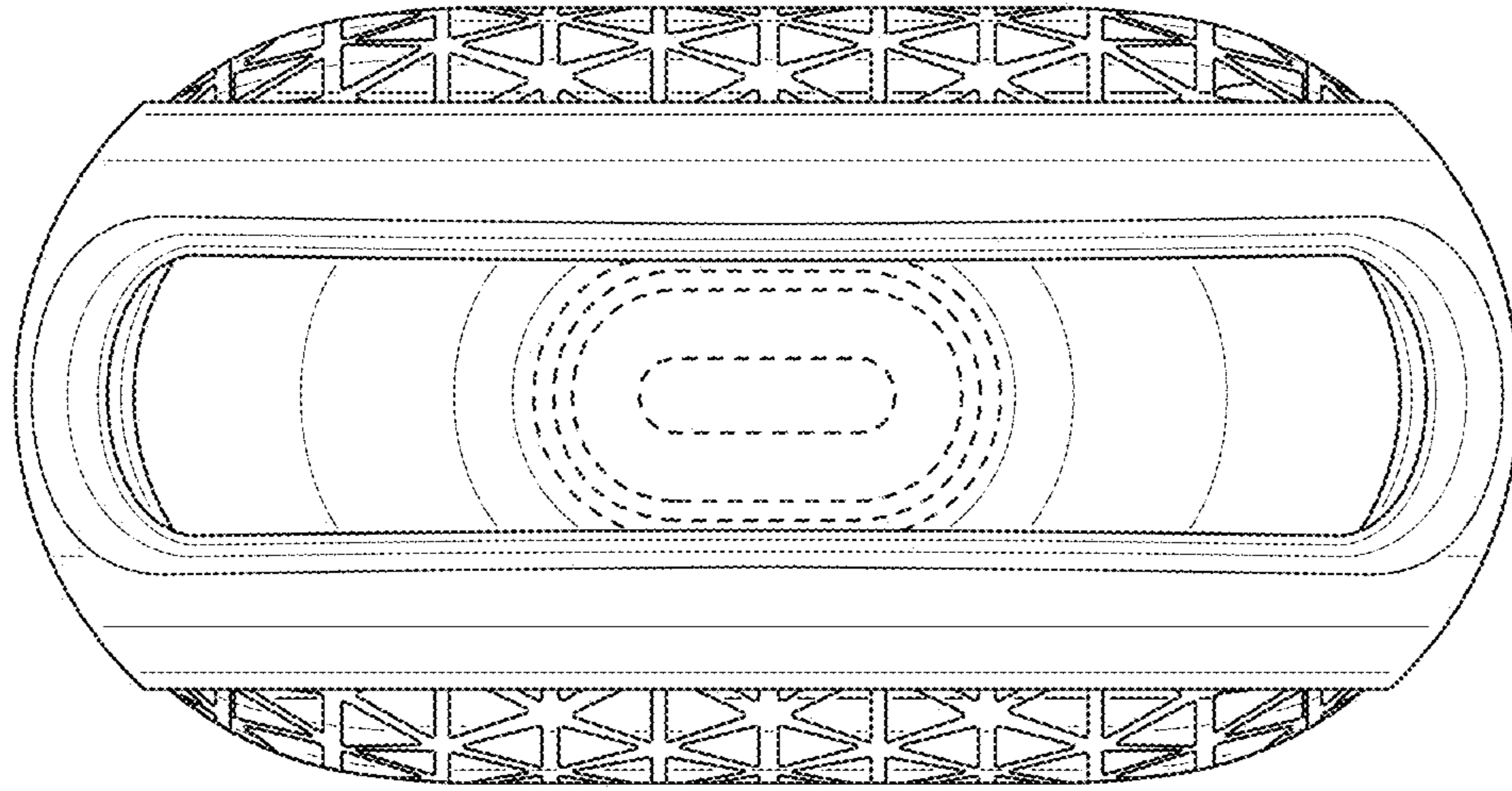

FIG. 15

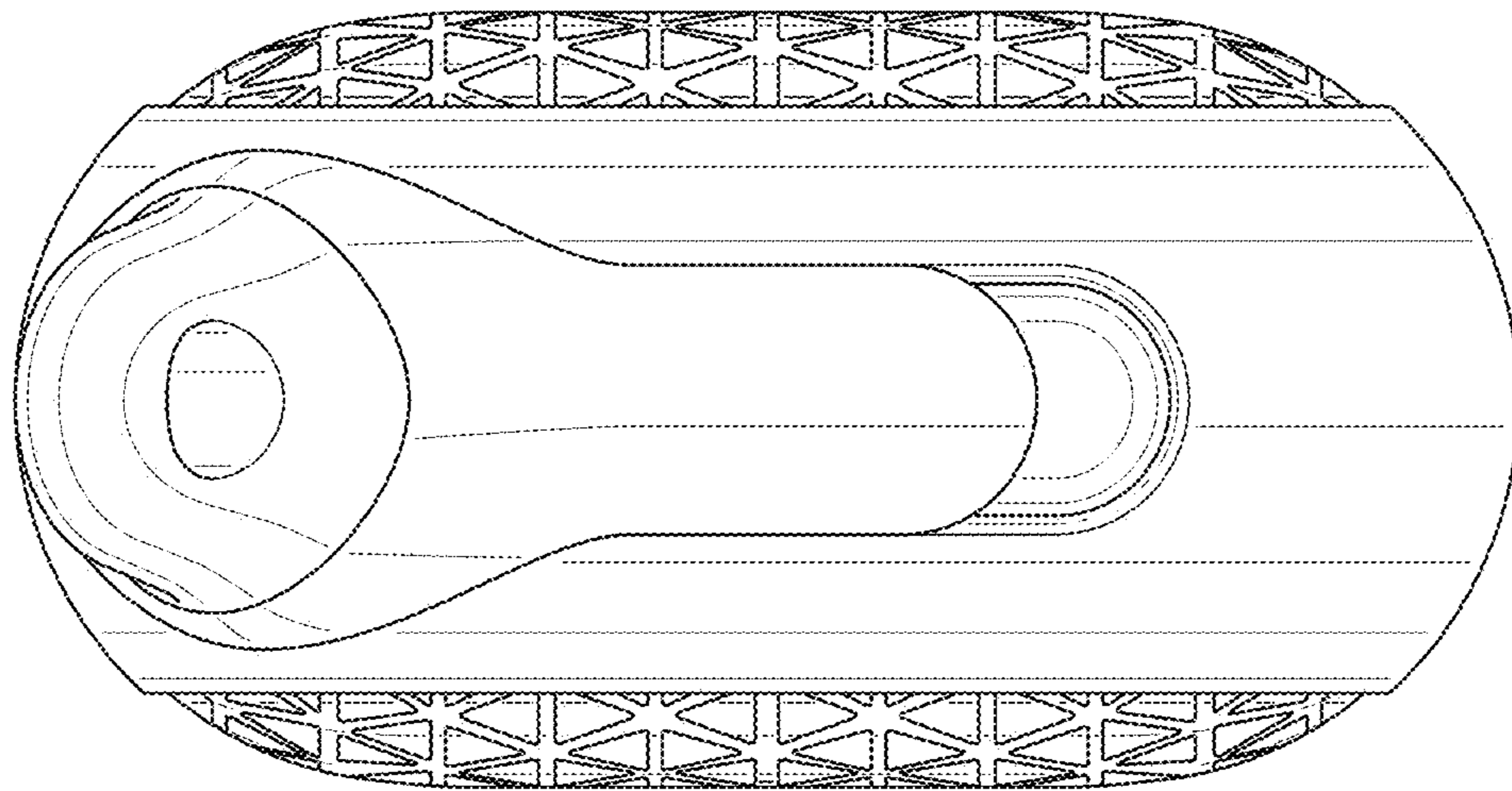

FIG. 16



FIG. 17

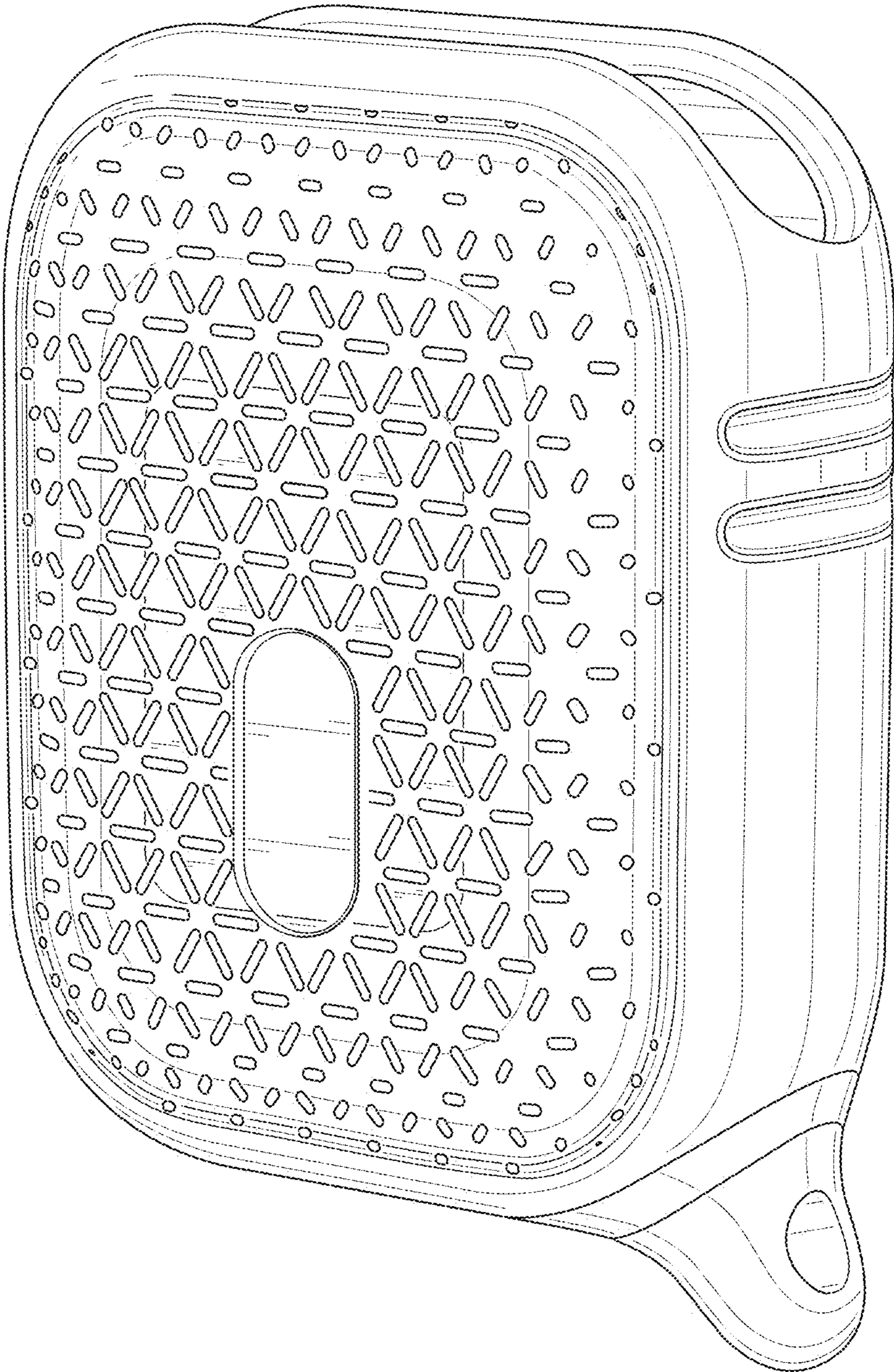

FIG. 18

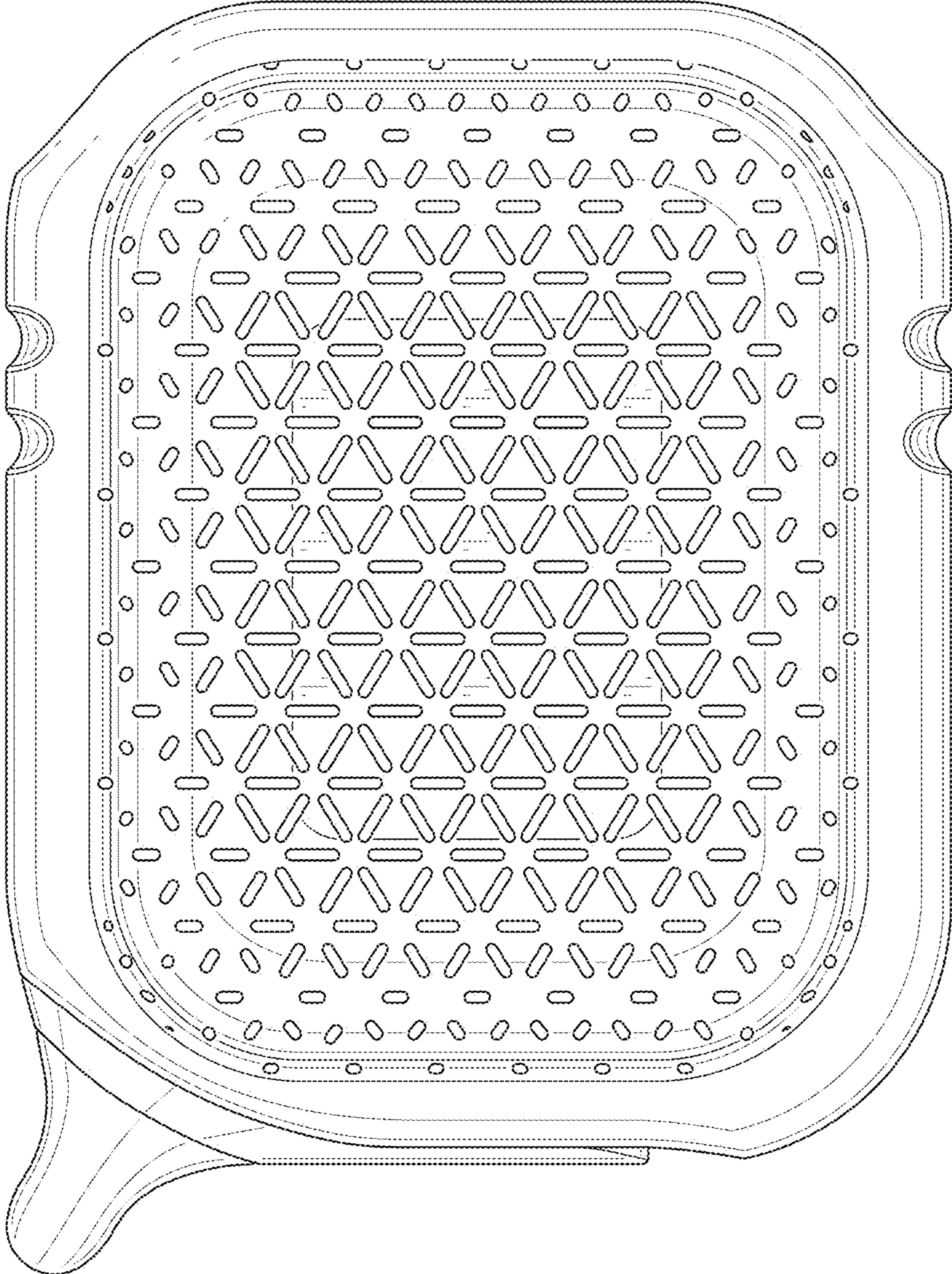

FIG. 19

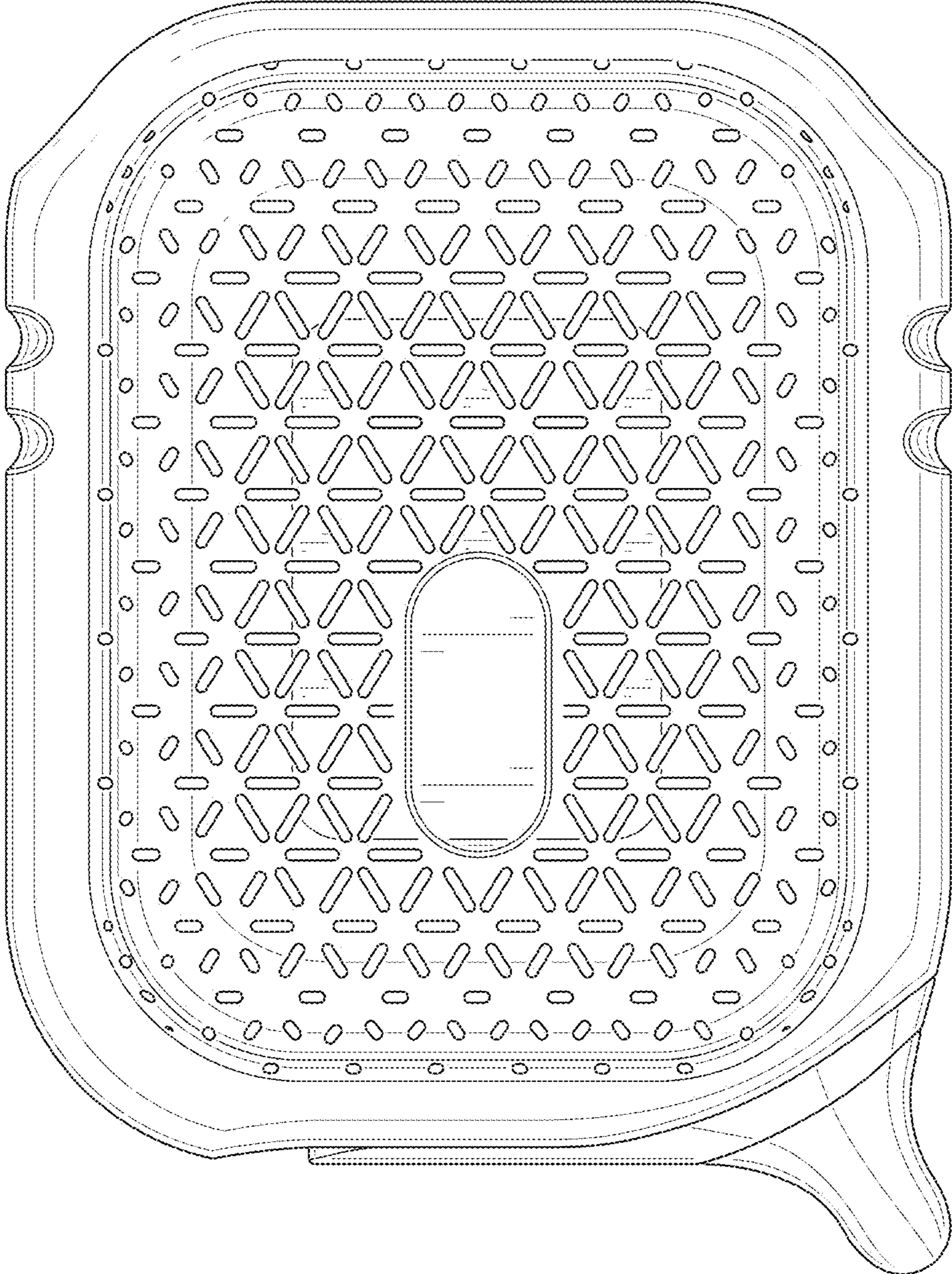

FIG. 20

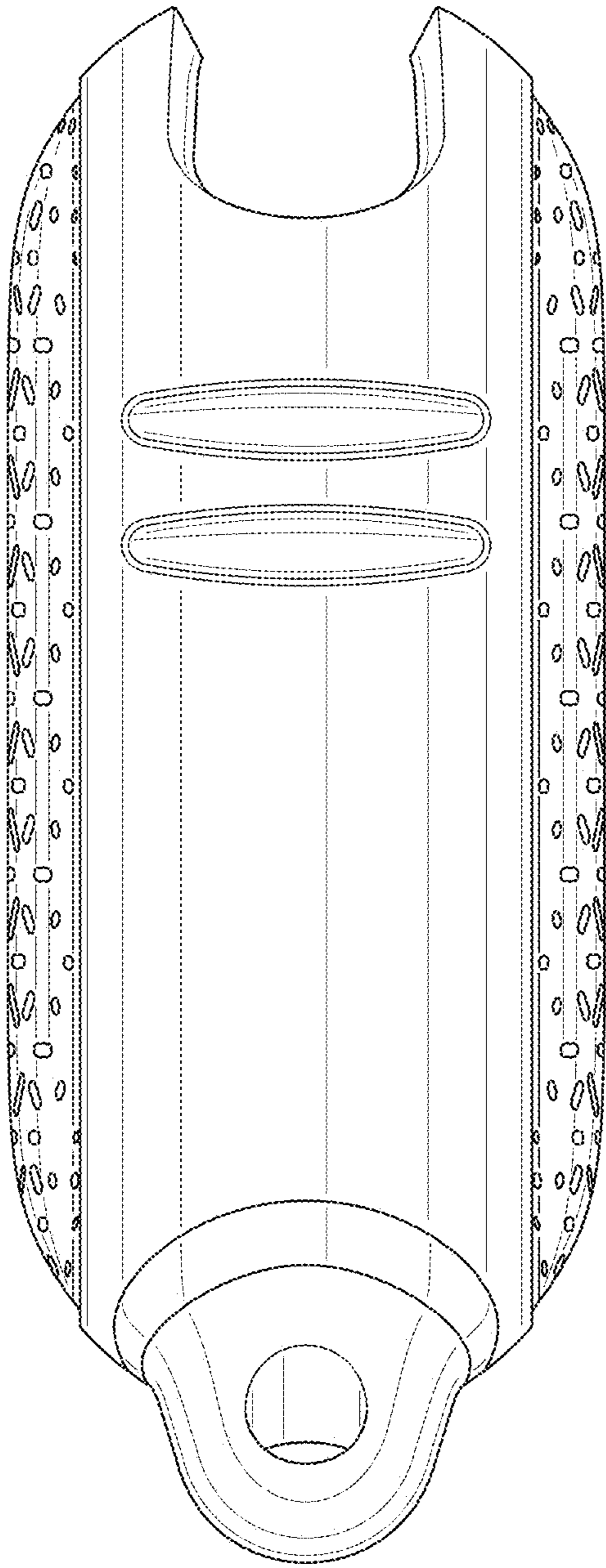

FIG. 21

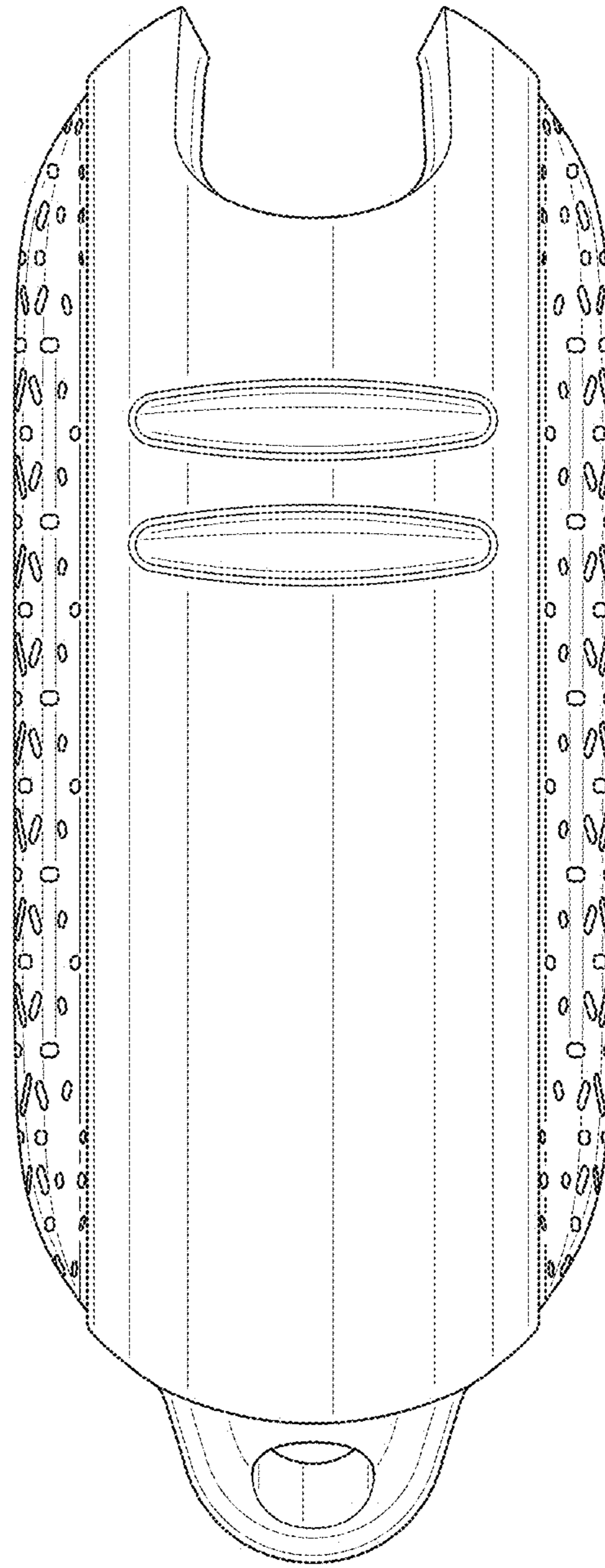

FIG. 22

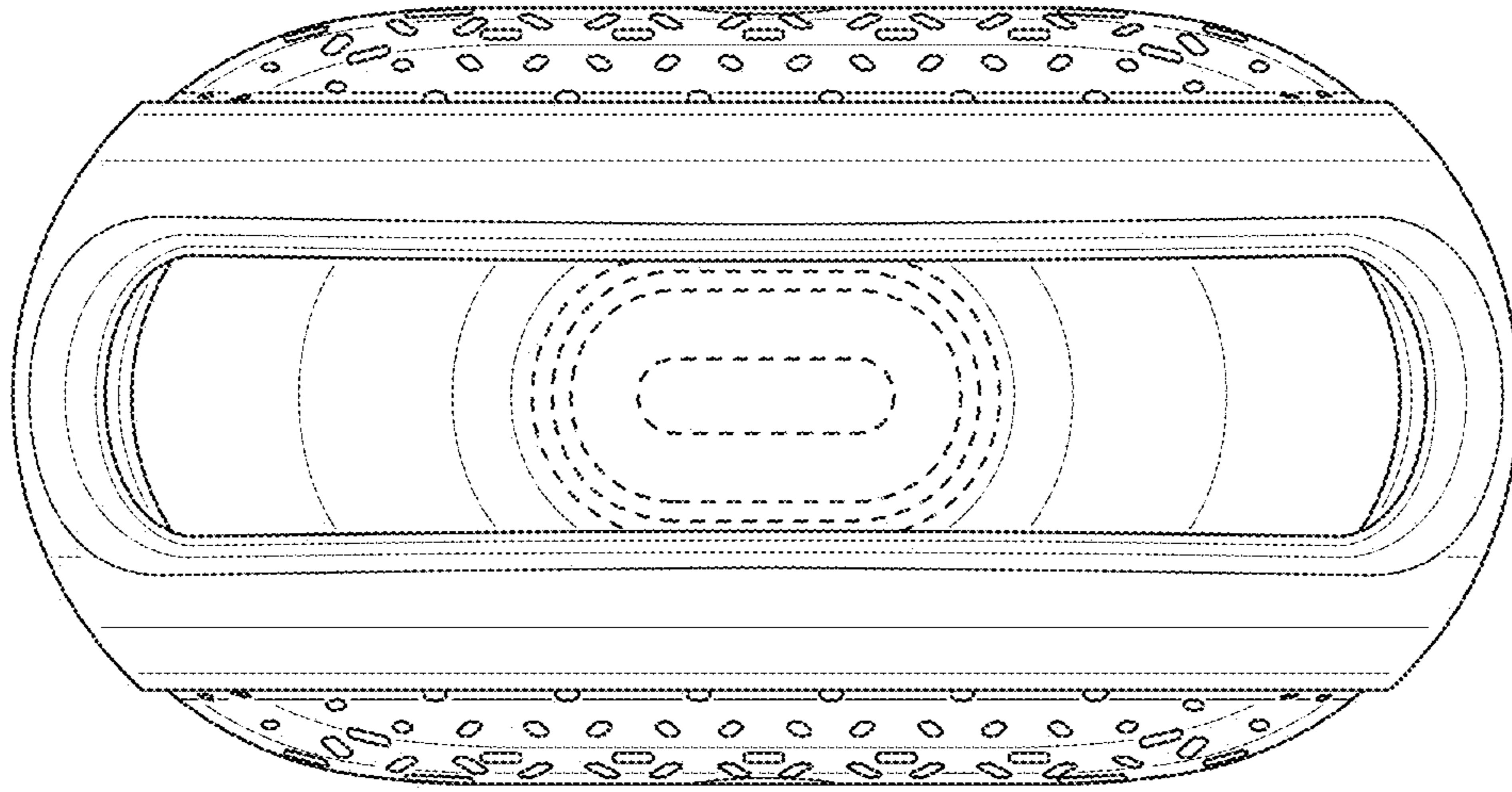

FIG. 23

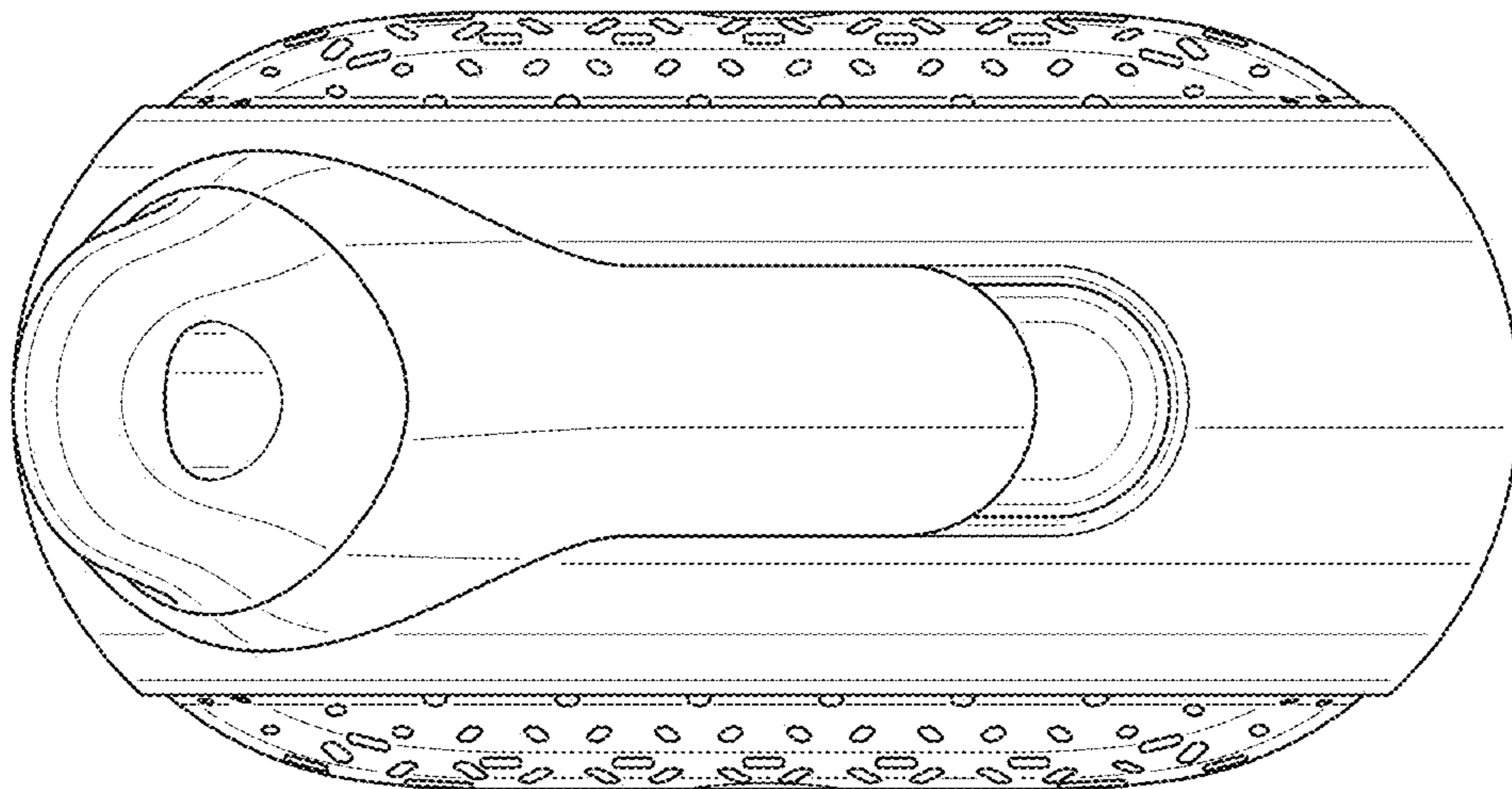

FIG. 24

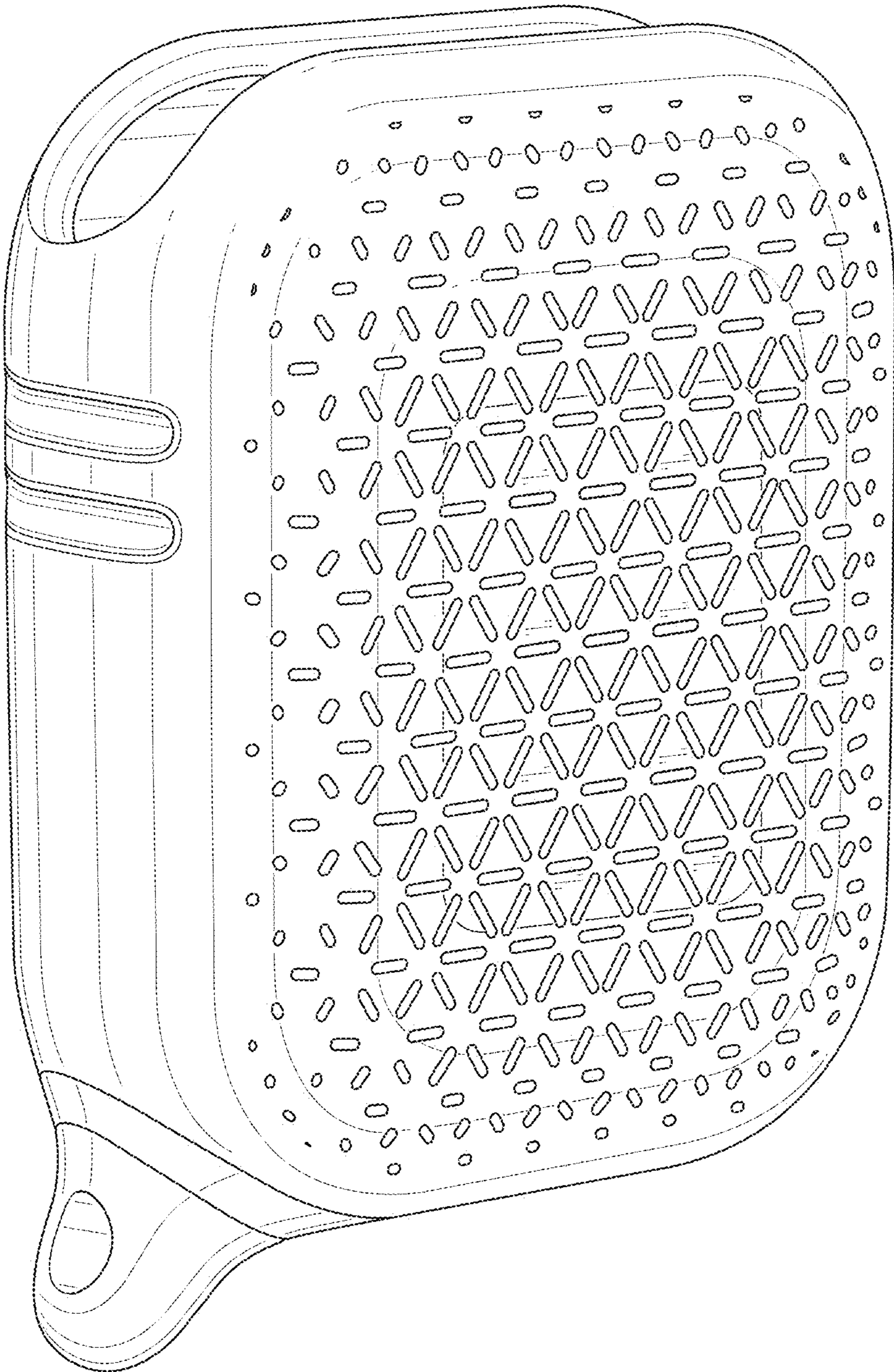

FIG. 25

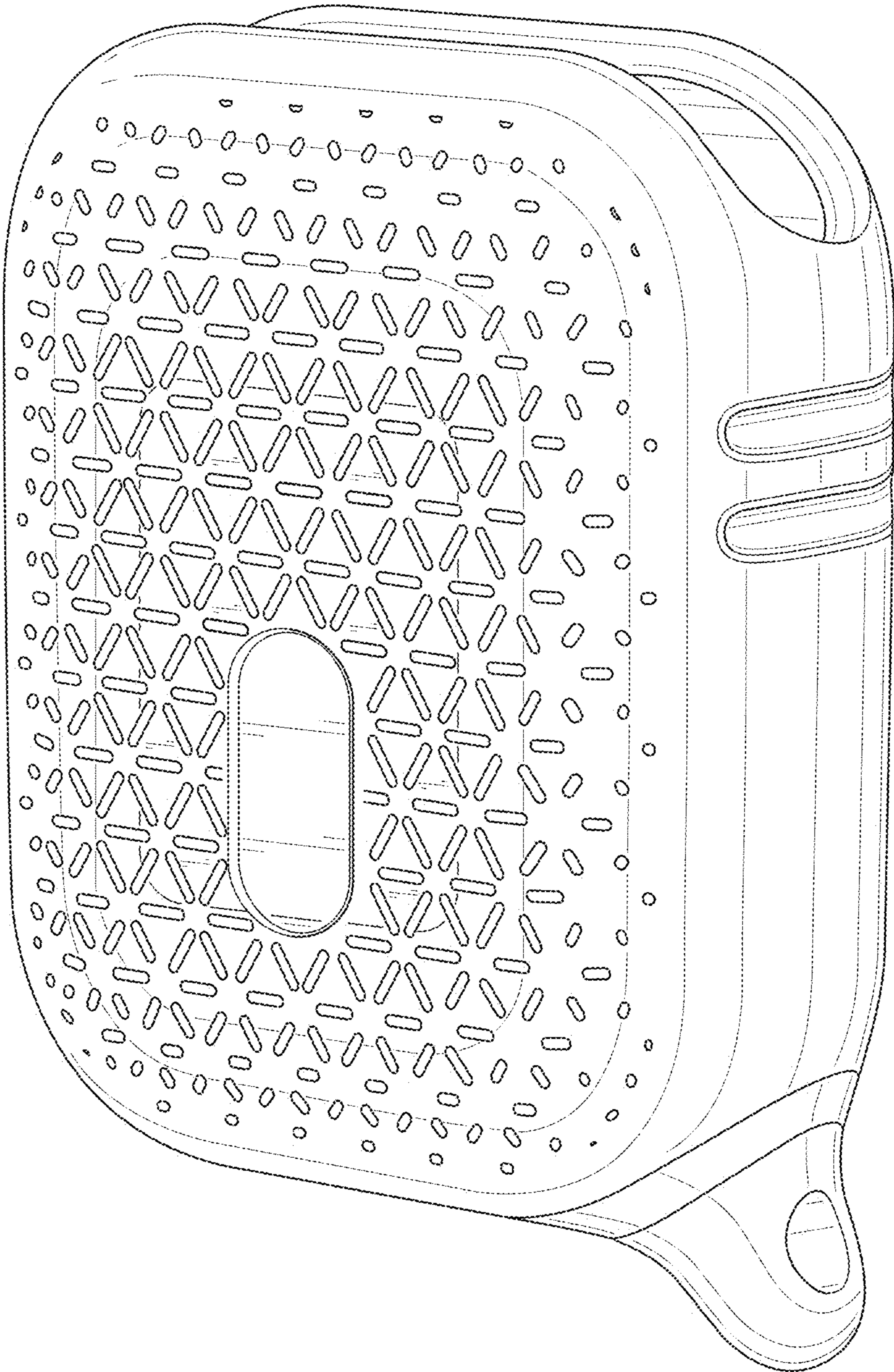

FIG. 26

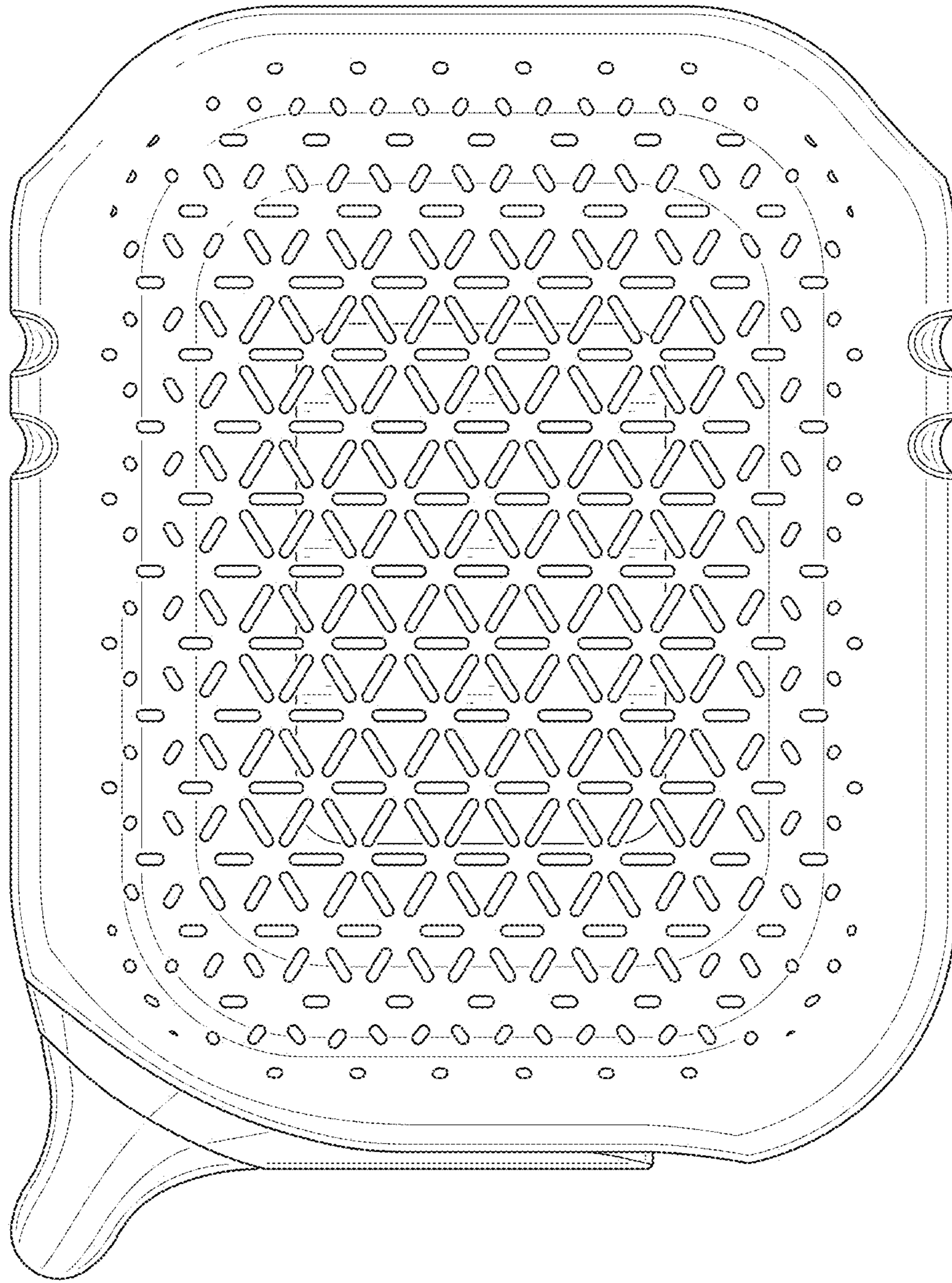

FIG. 27

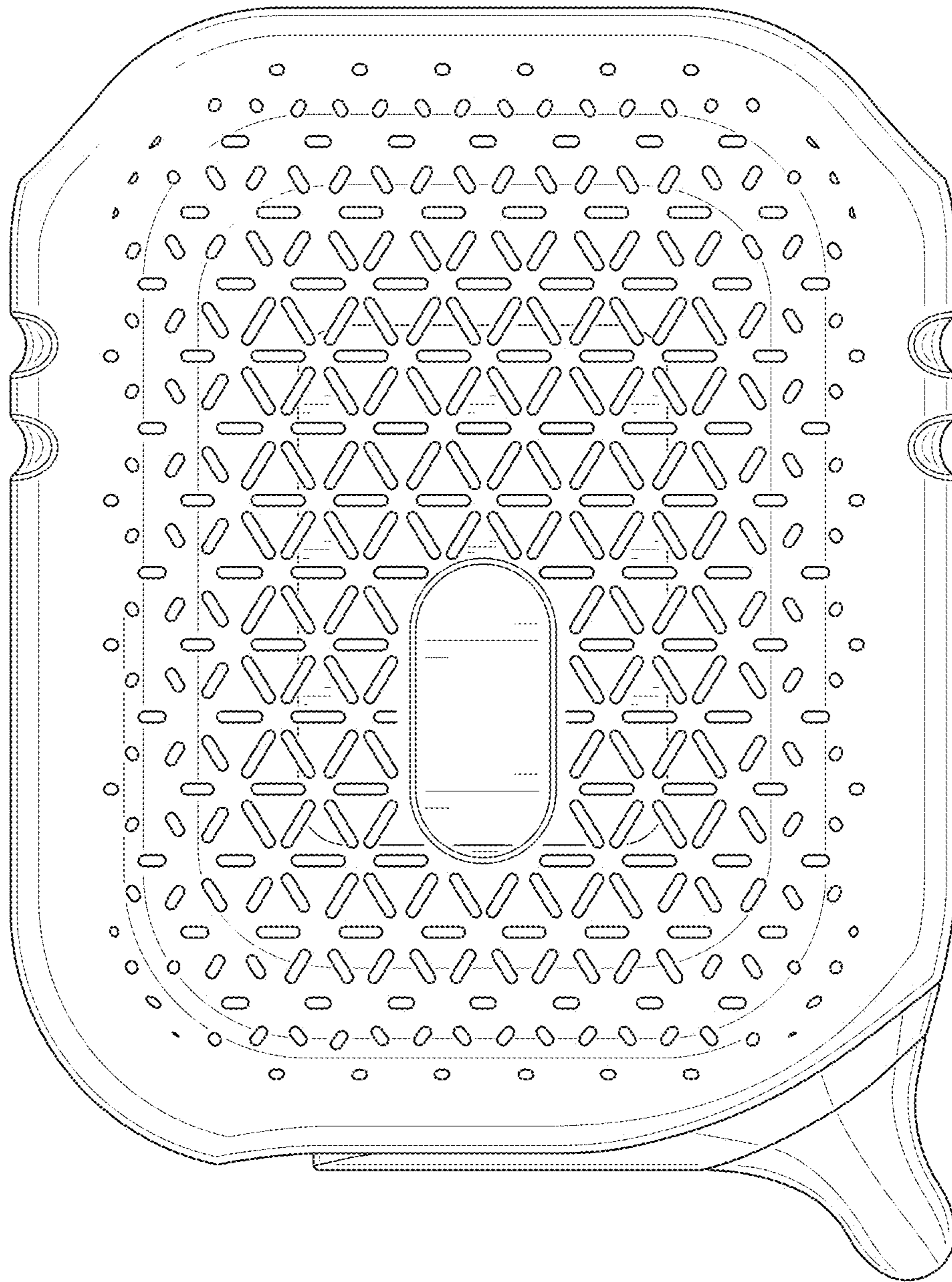

FIG. 28

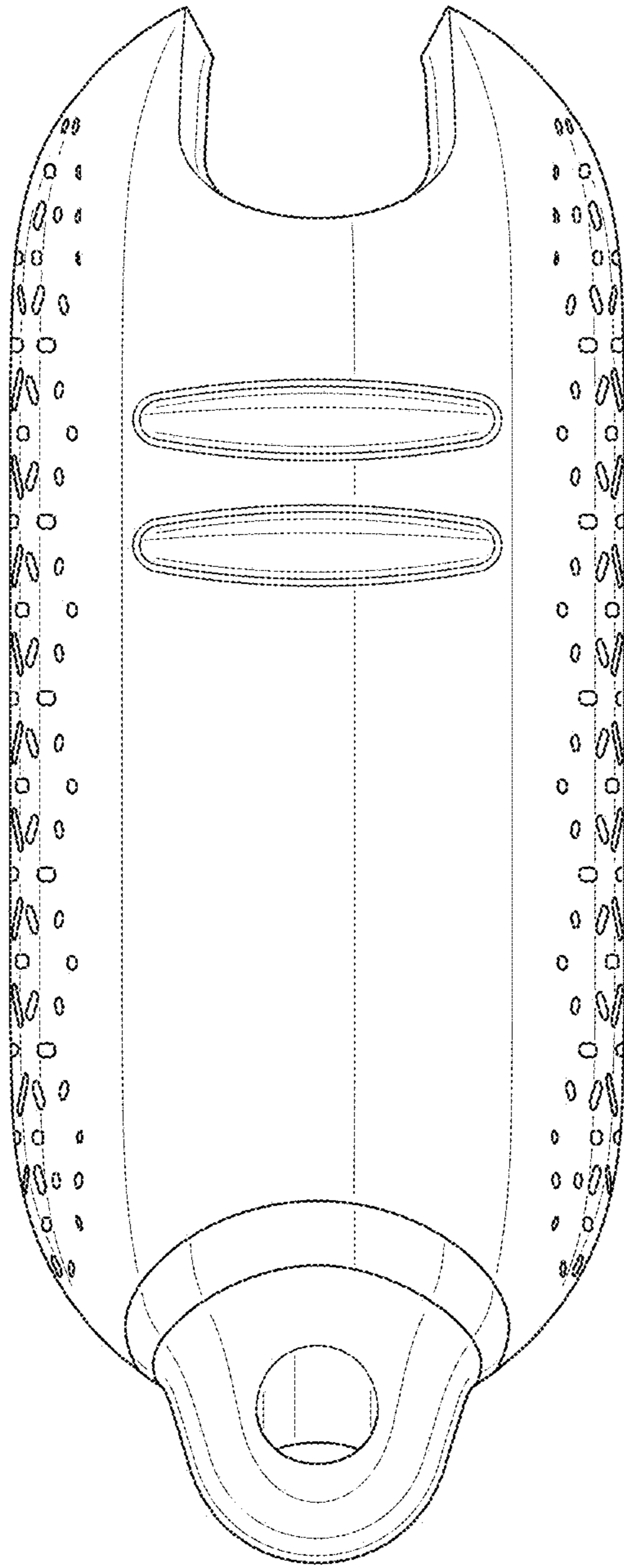

FIG. 29

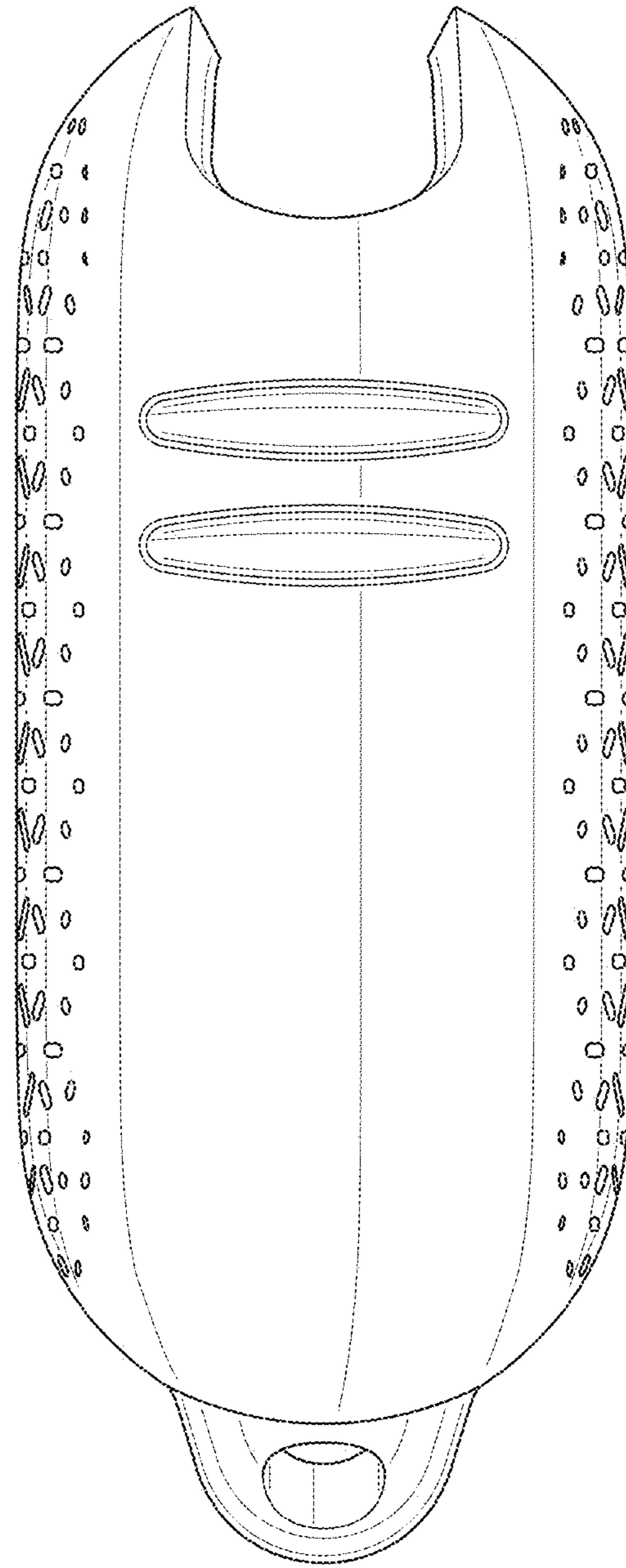

FIG. 30

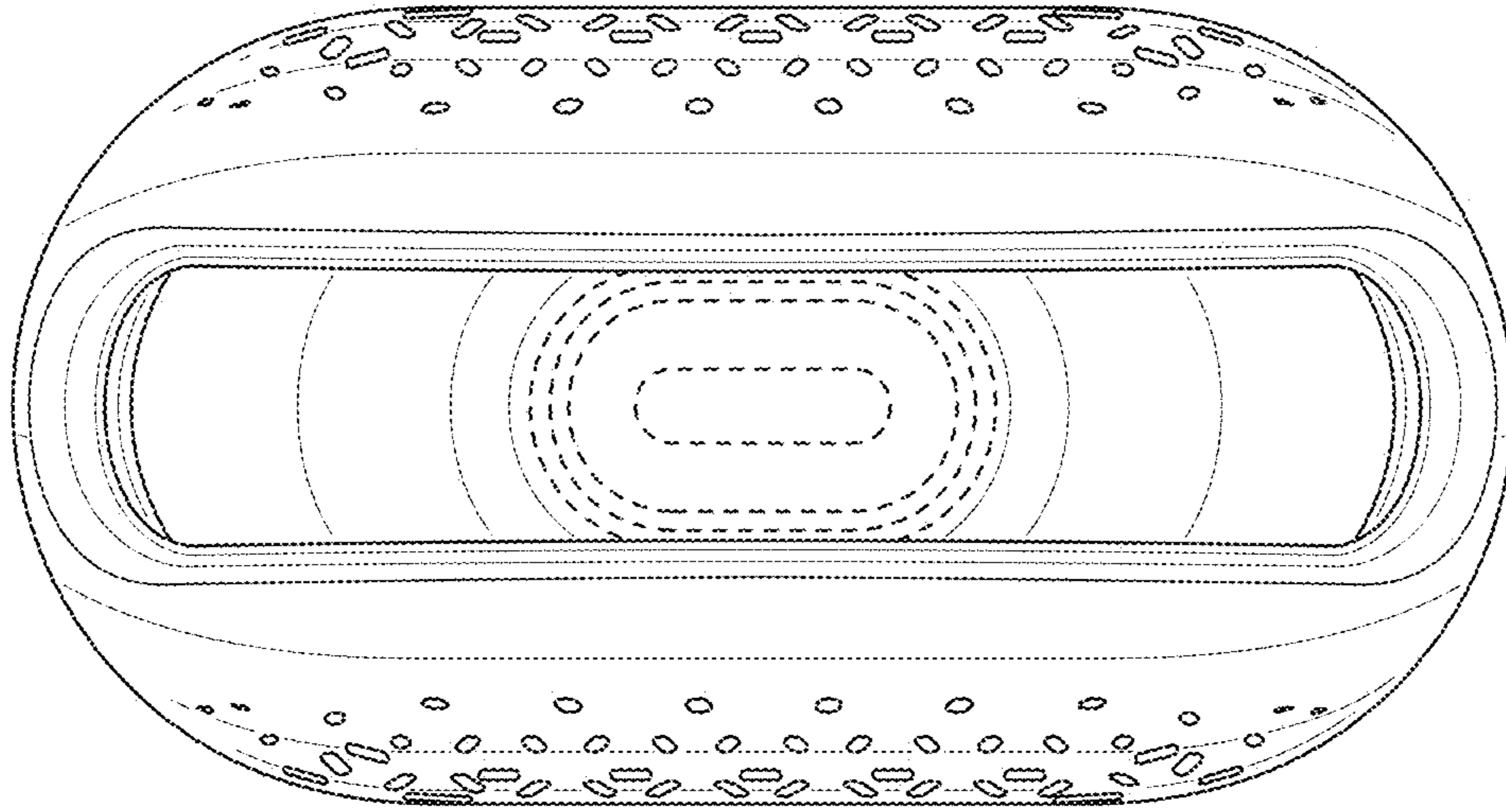

FIG. 31

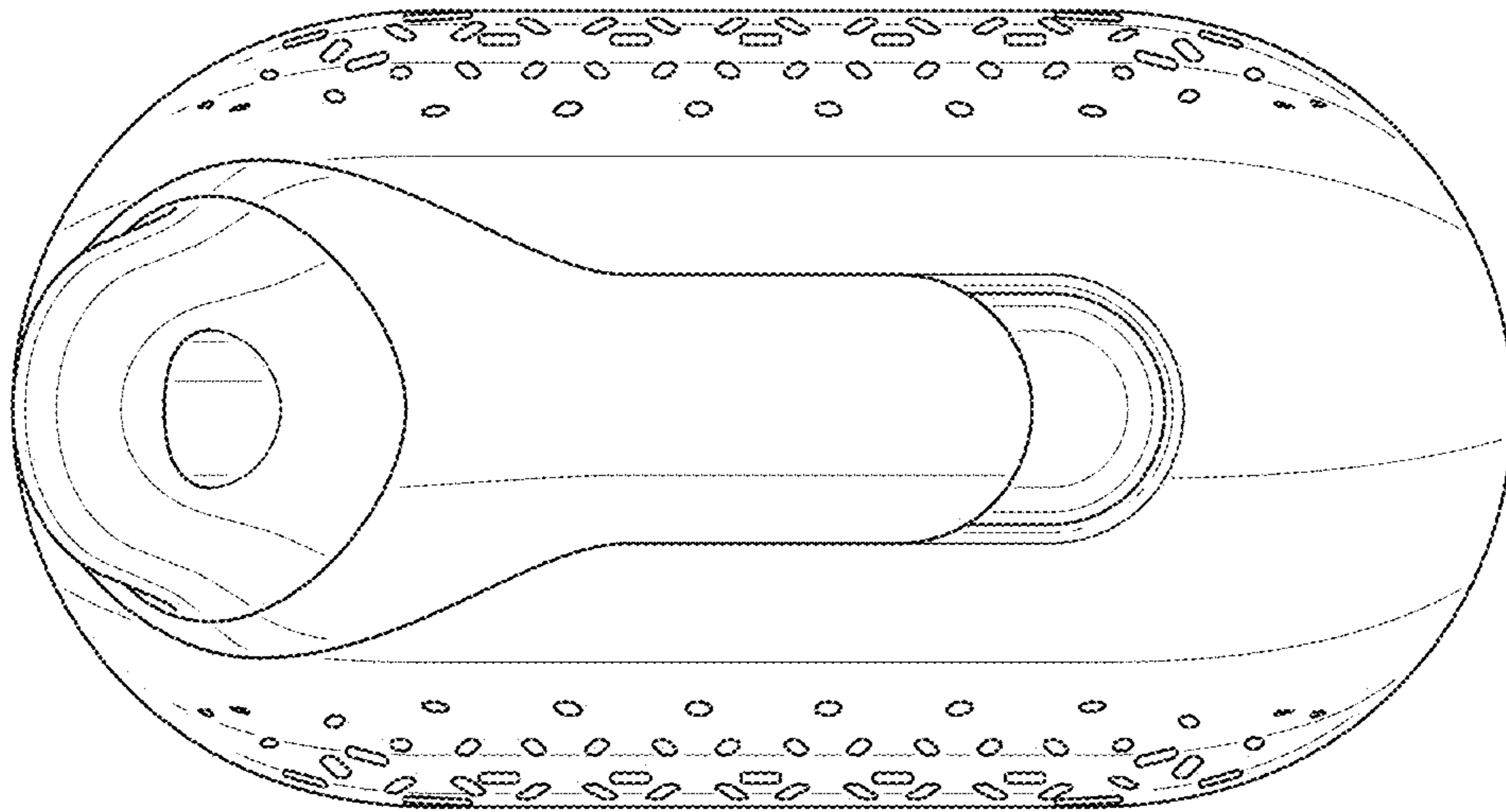

FIG. 32

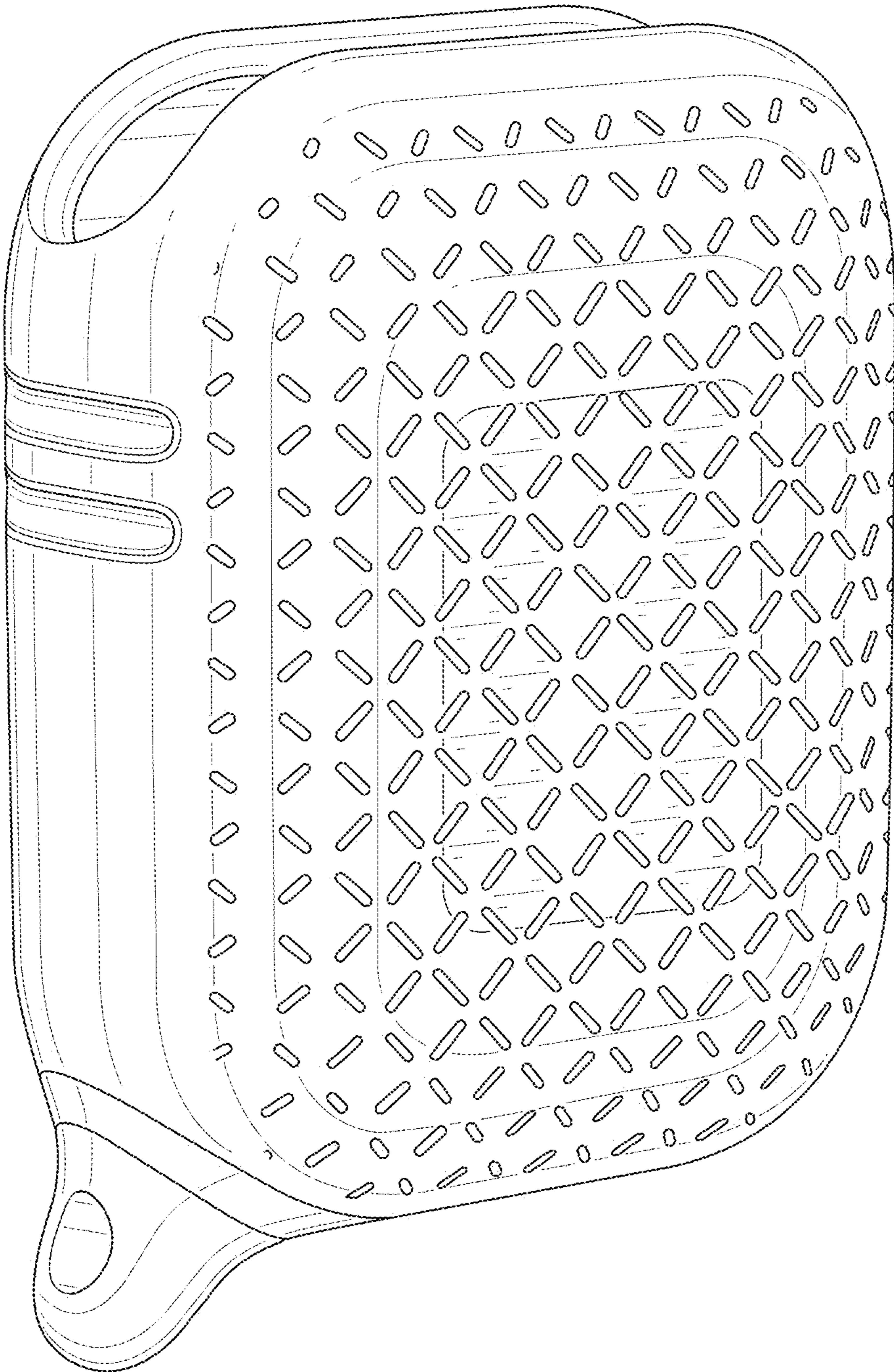

FIG. 33

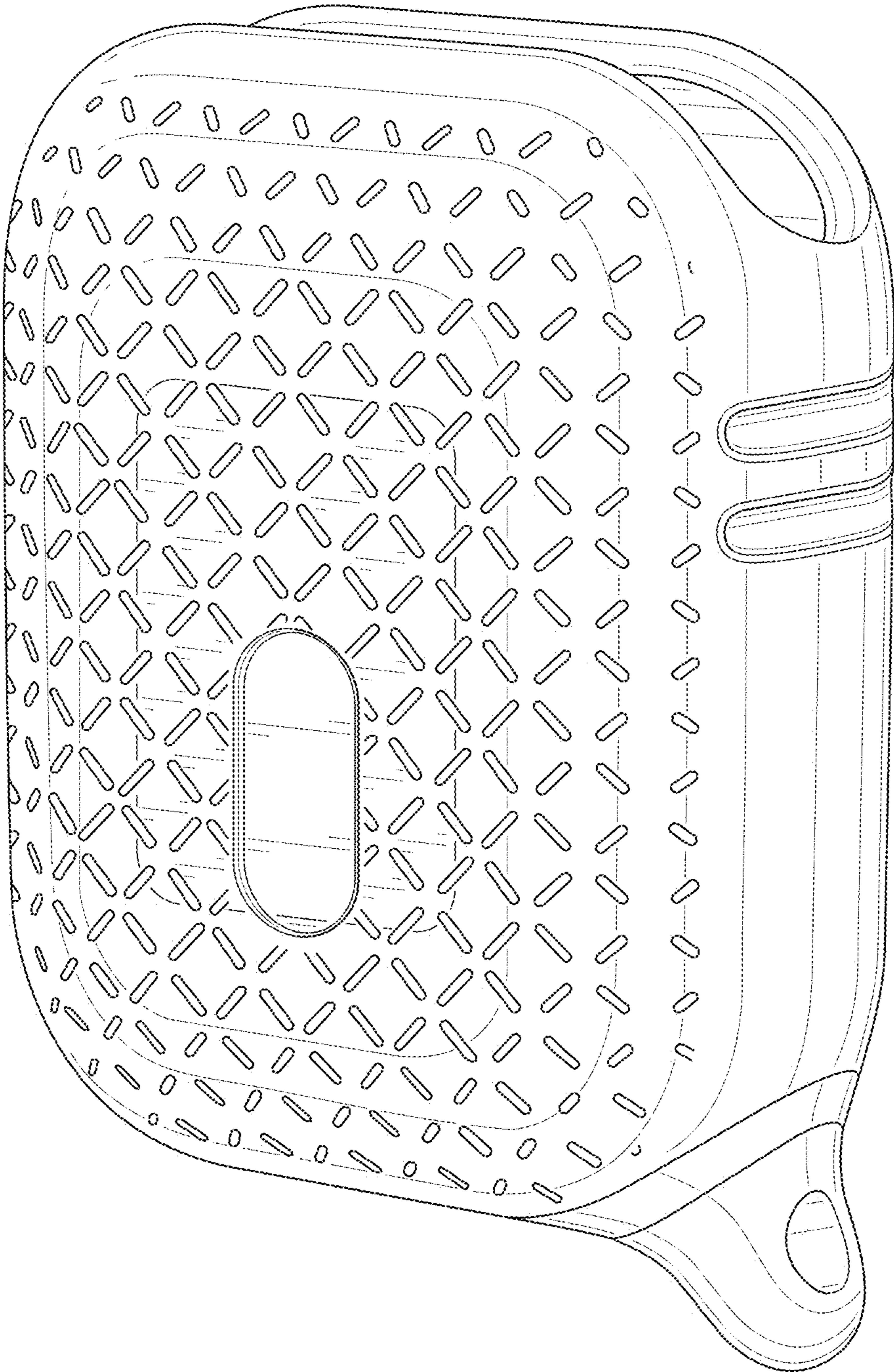

FIG. 34

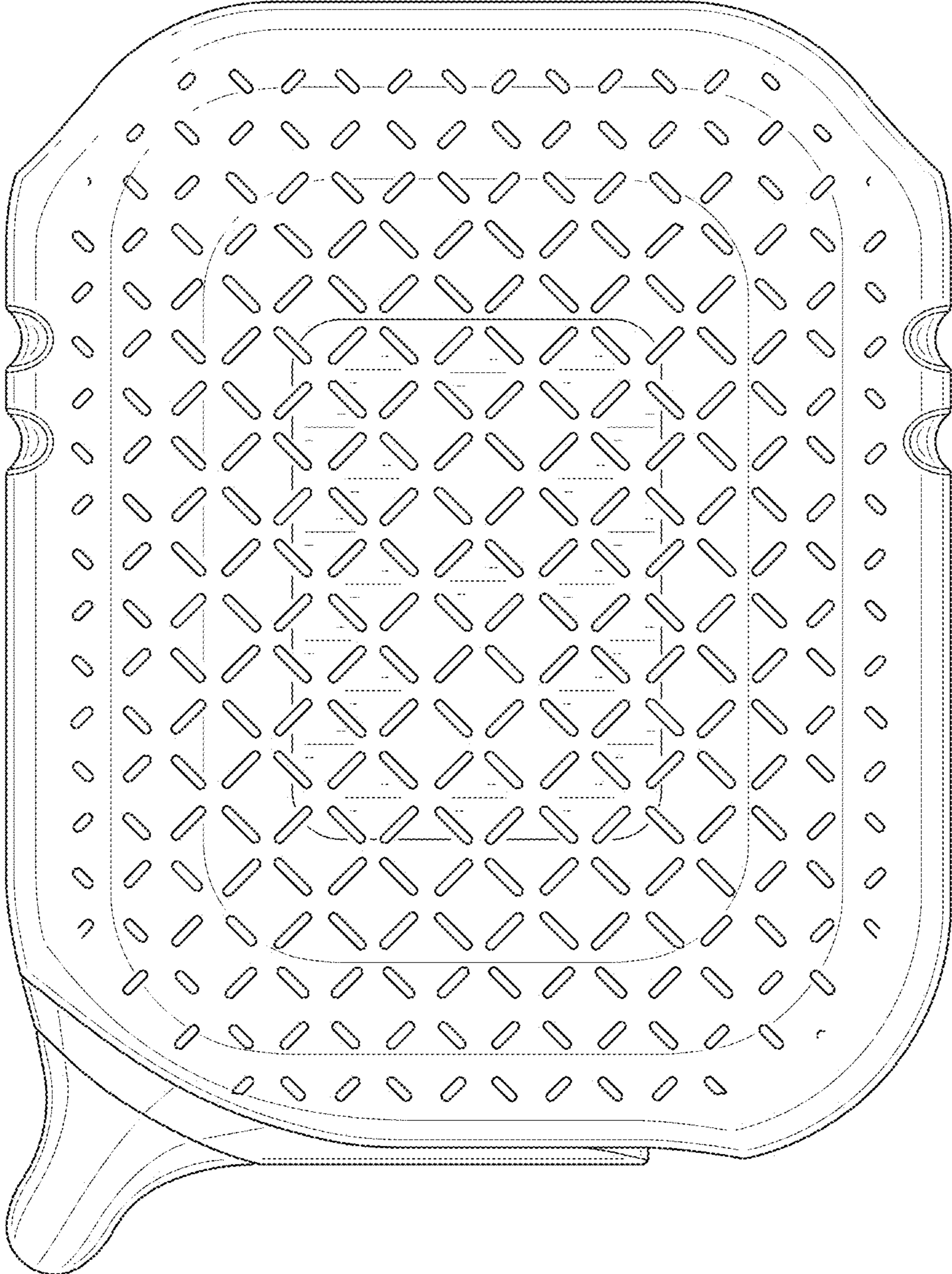

FIG. 35

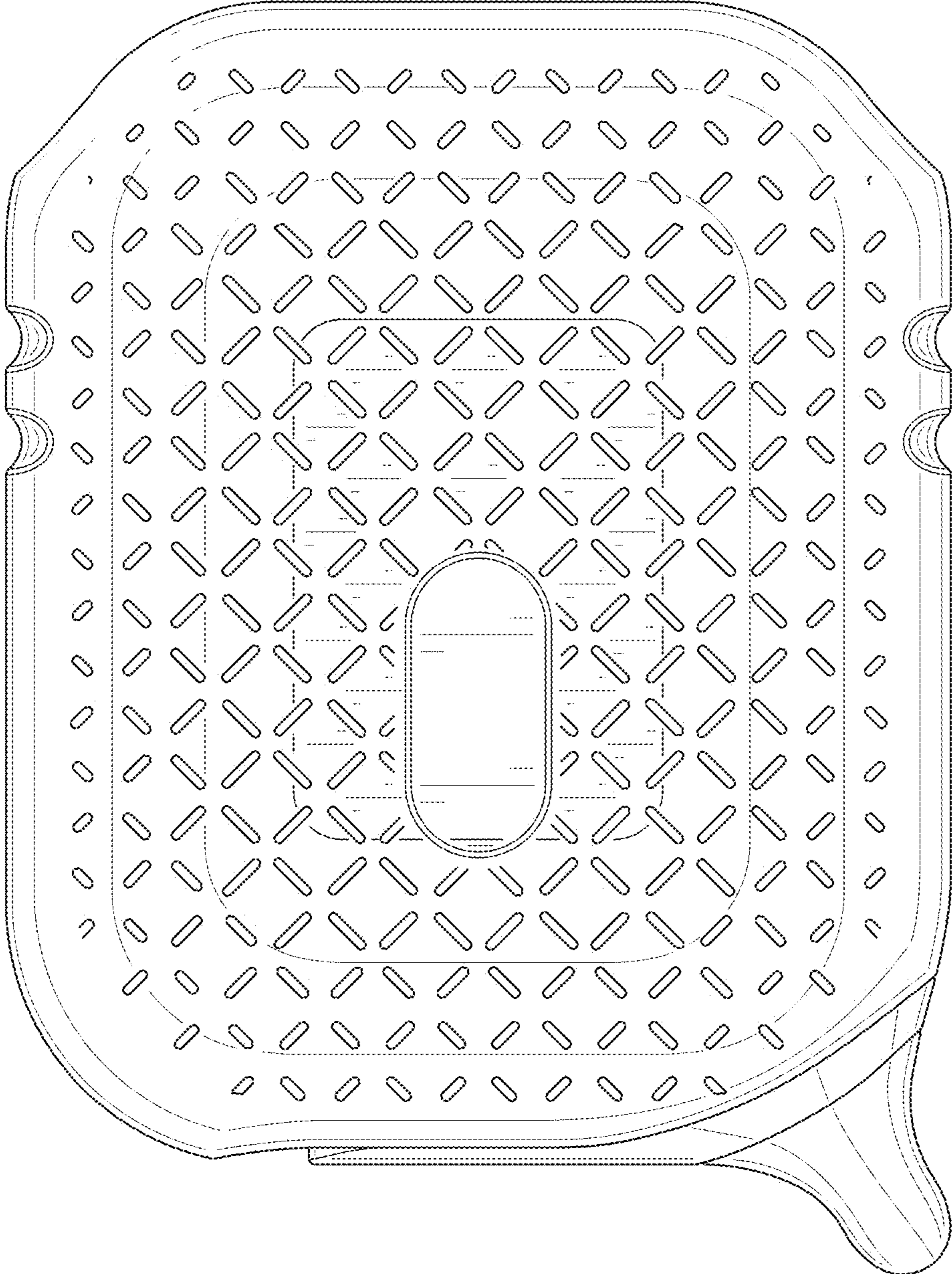

FIG. 36

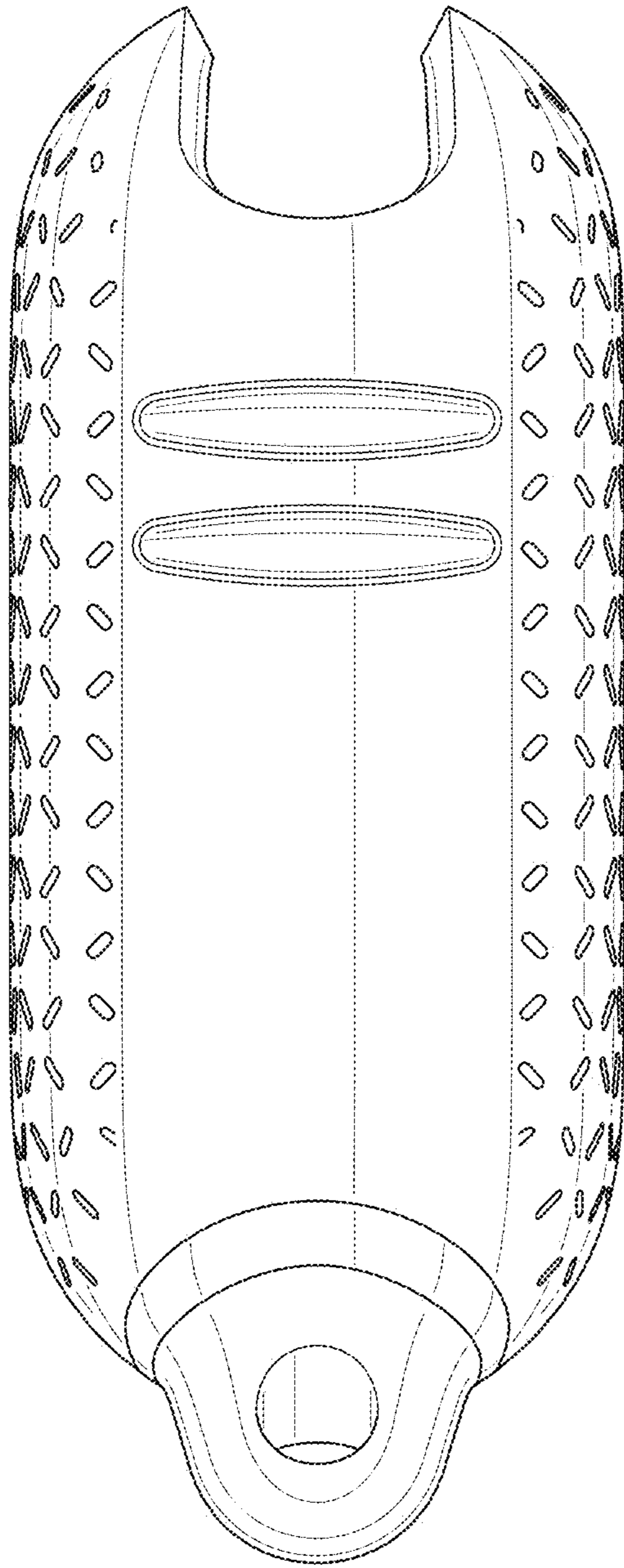

FIG. 37

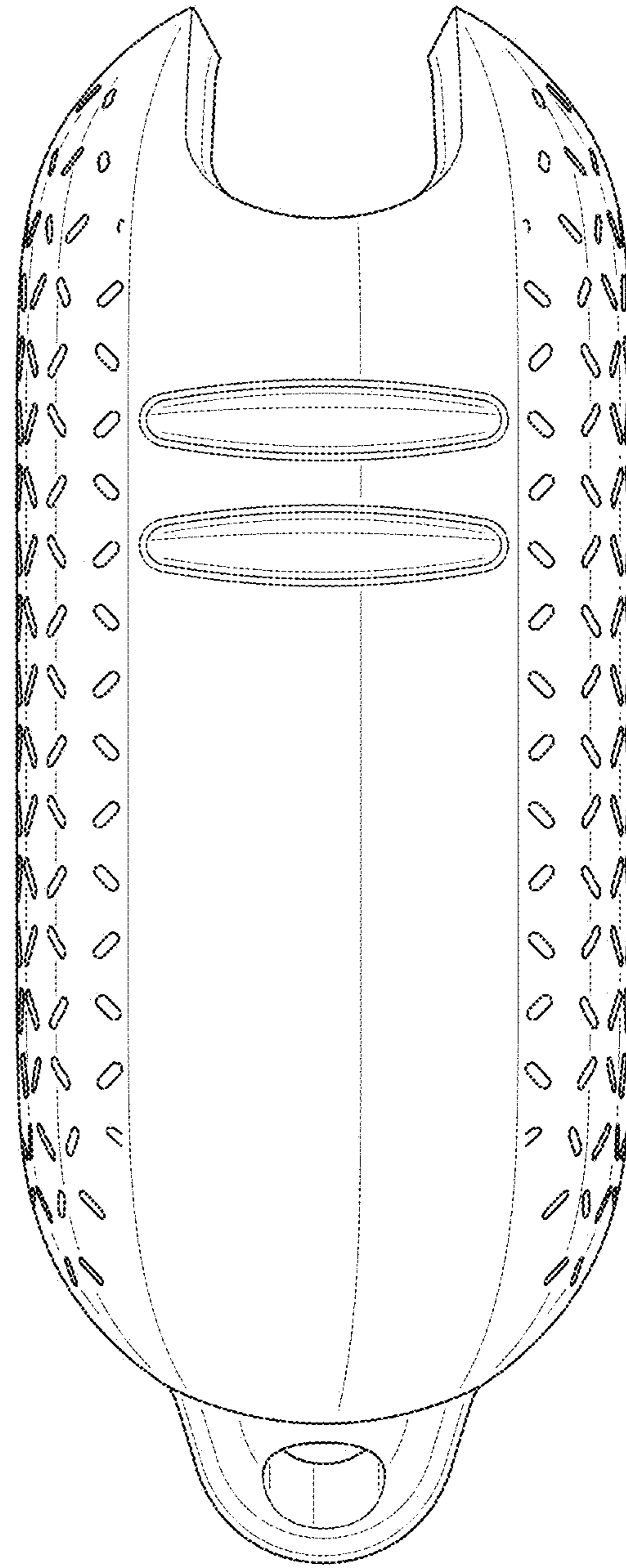

FIG. 38

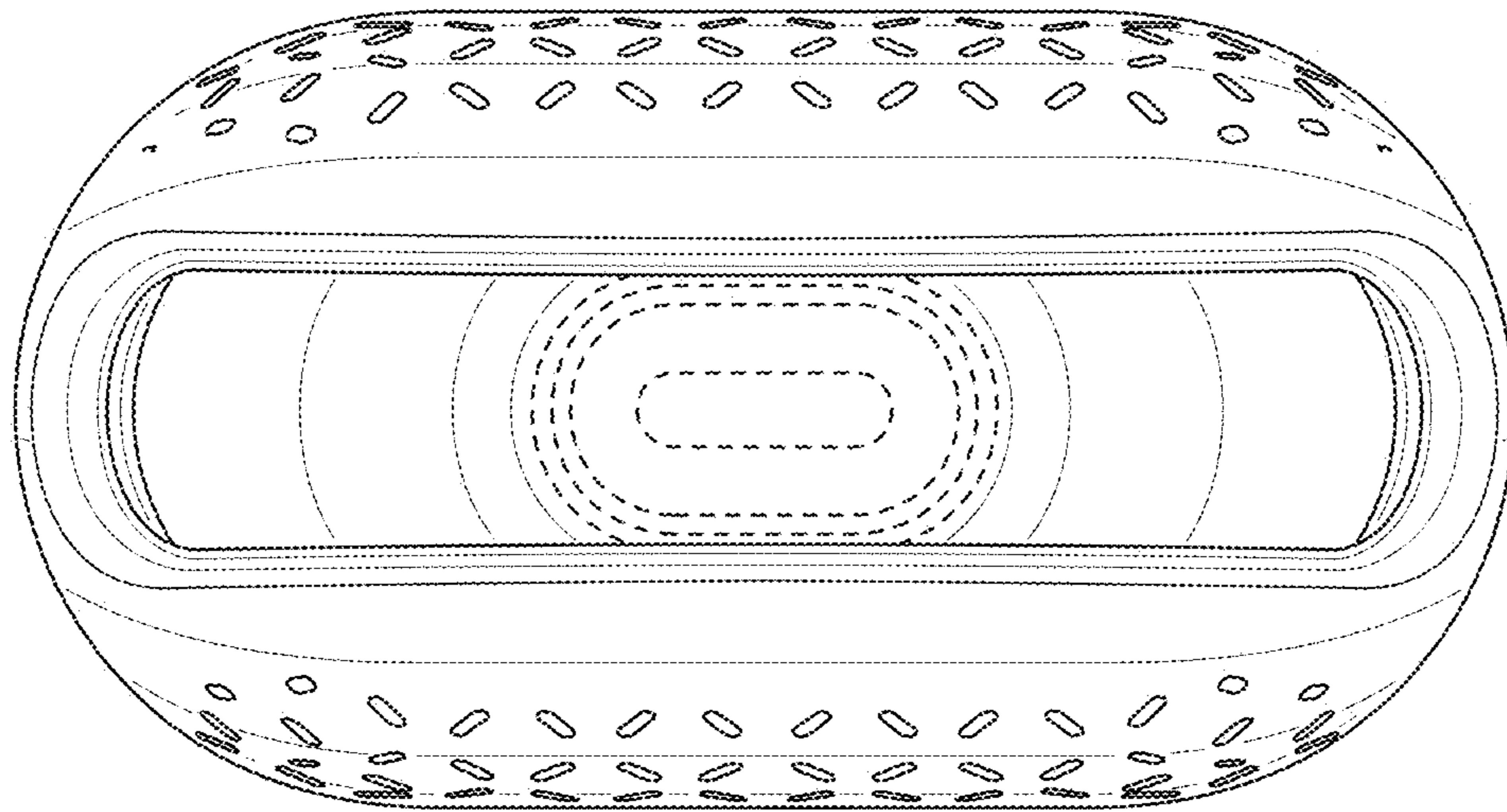

FIG. 39

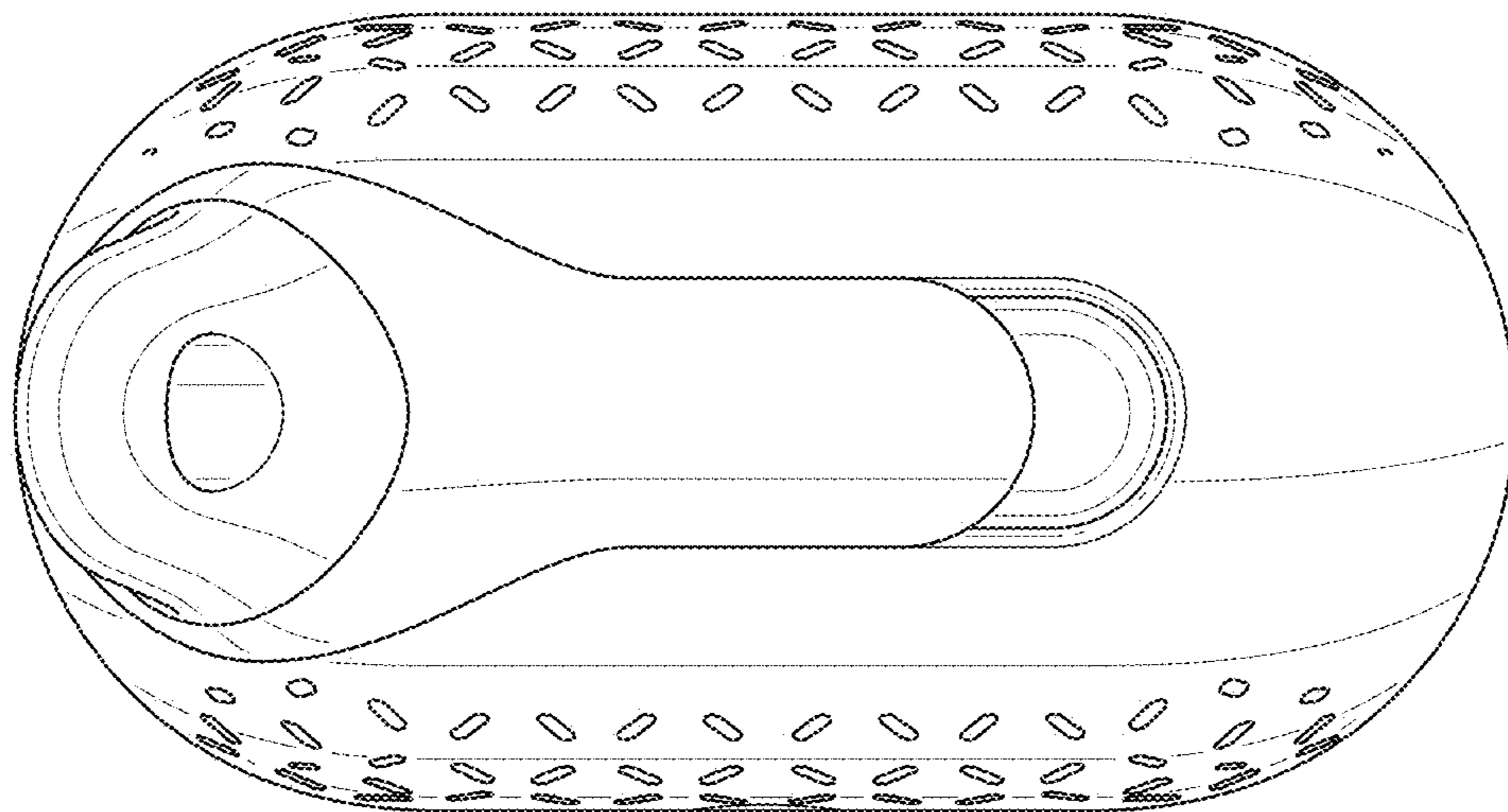

FIG. 40



FIG. 41

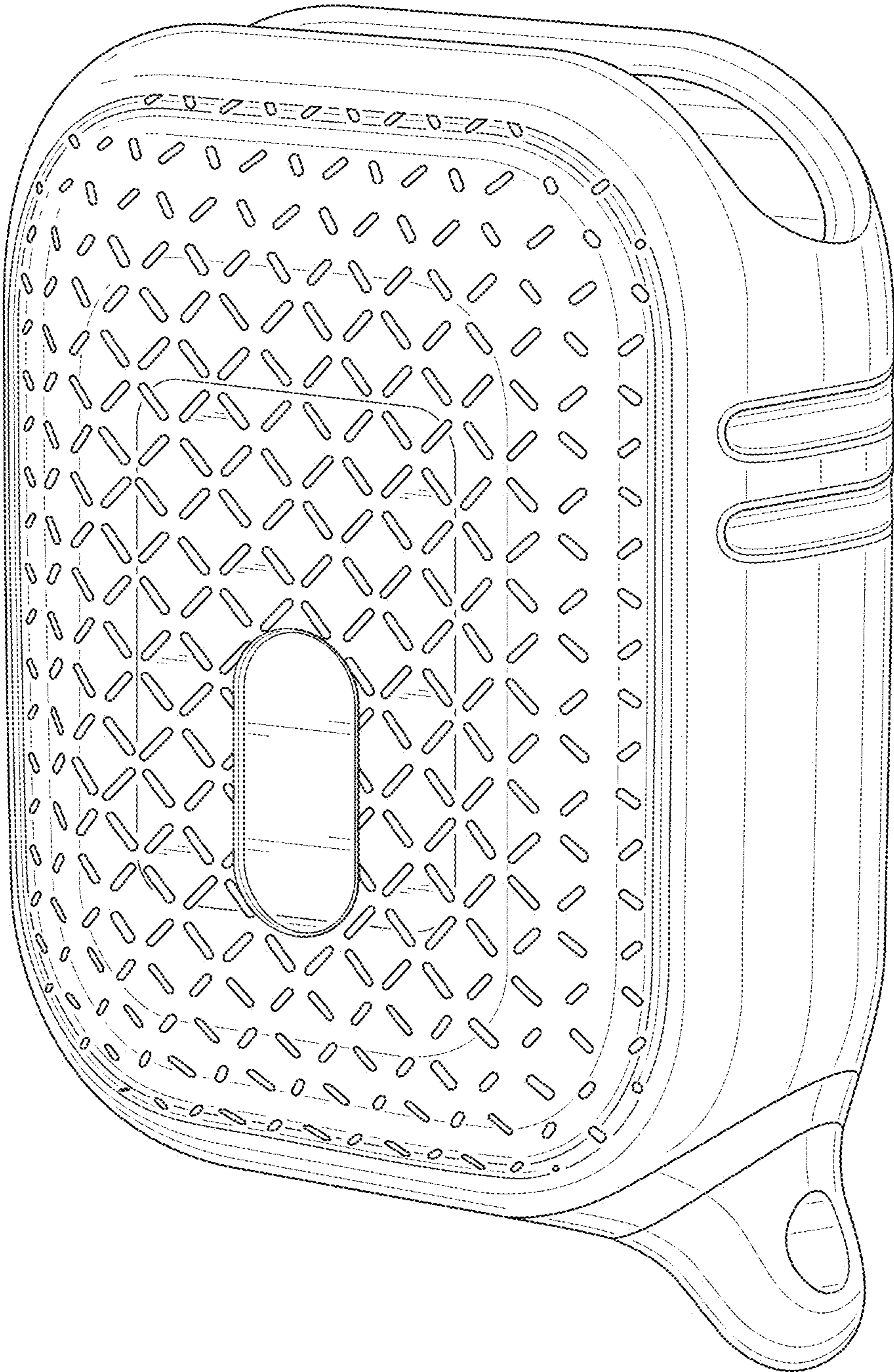

FIG. 42

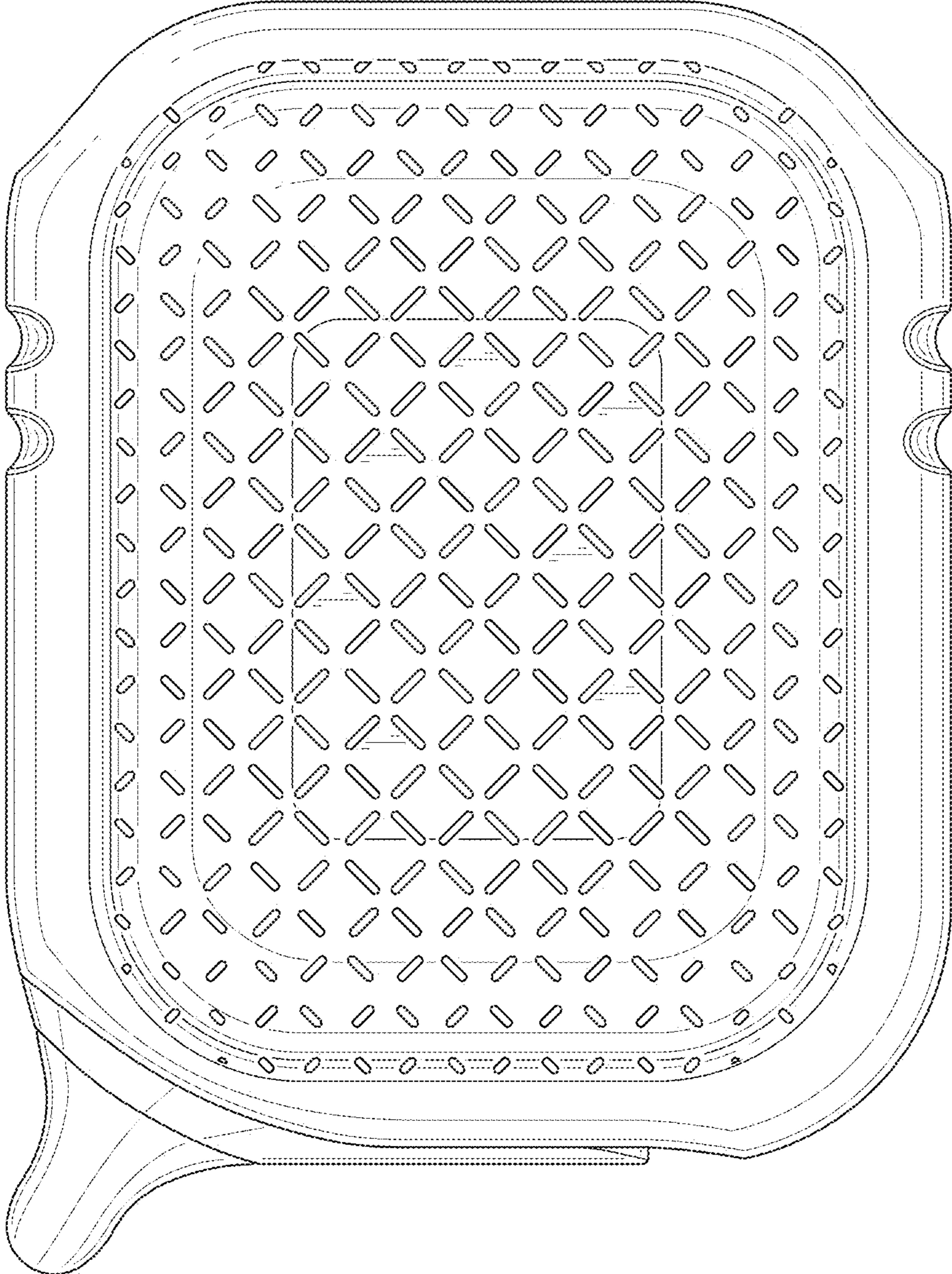

FIG. 43

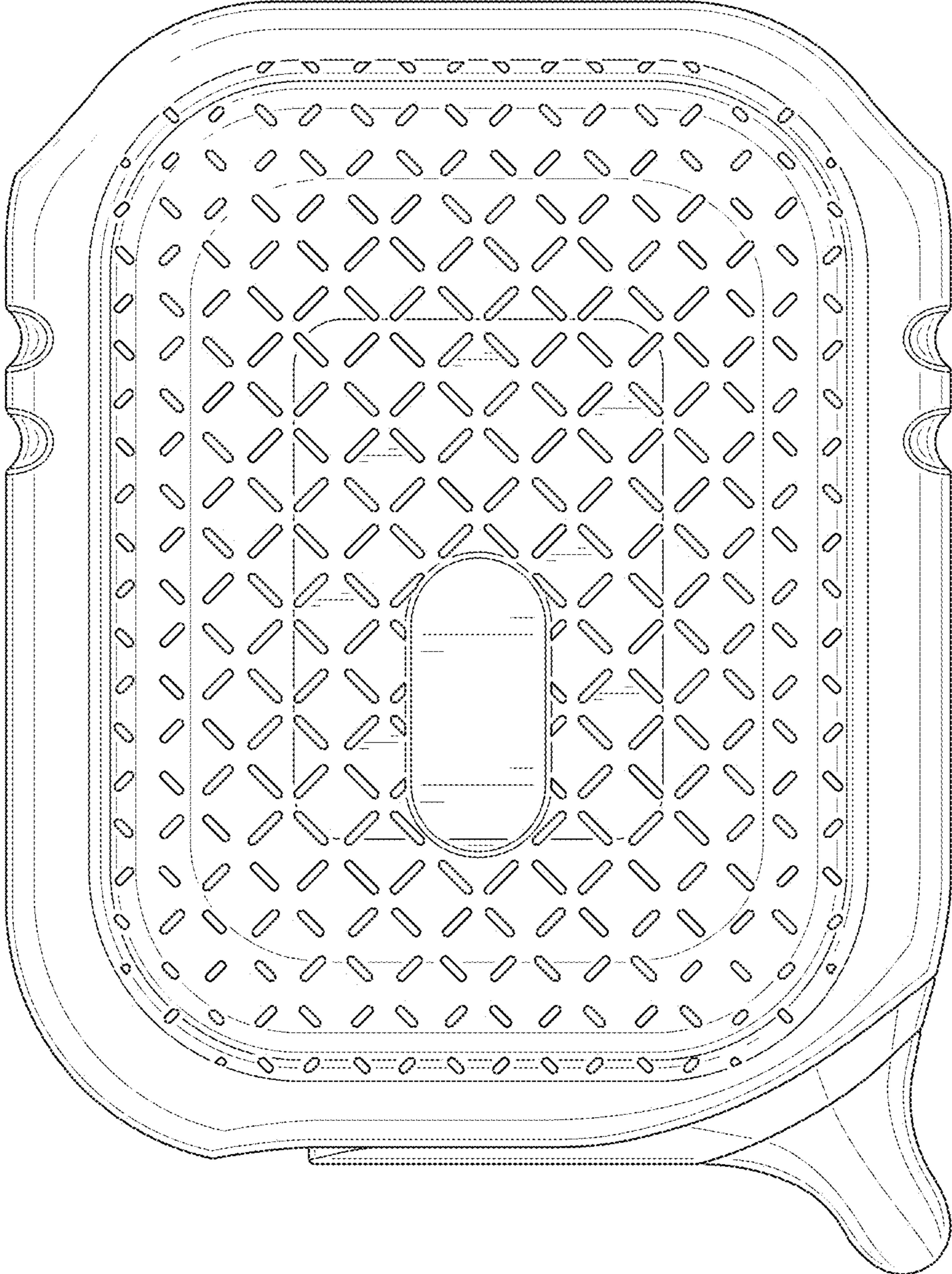

FIG. 44

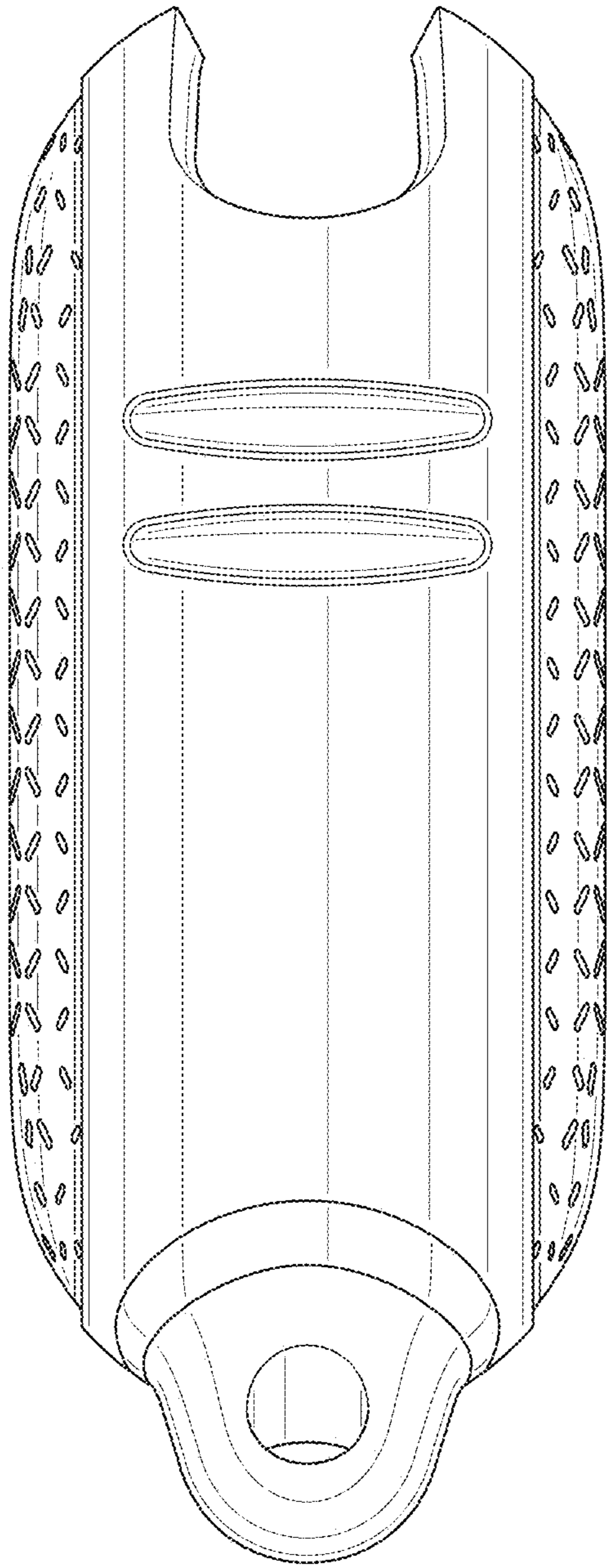

FIG. 45

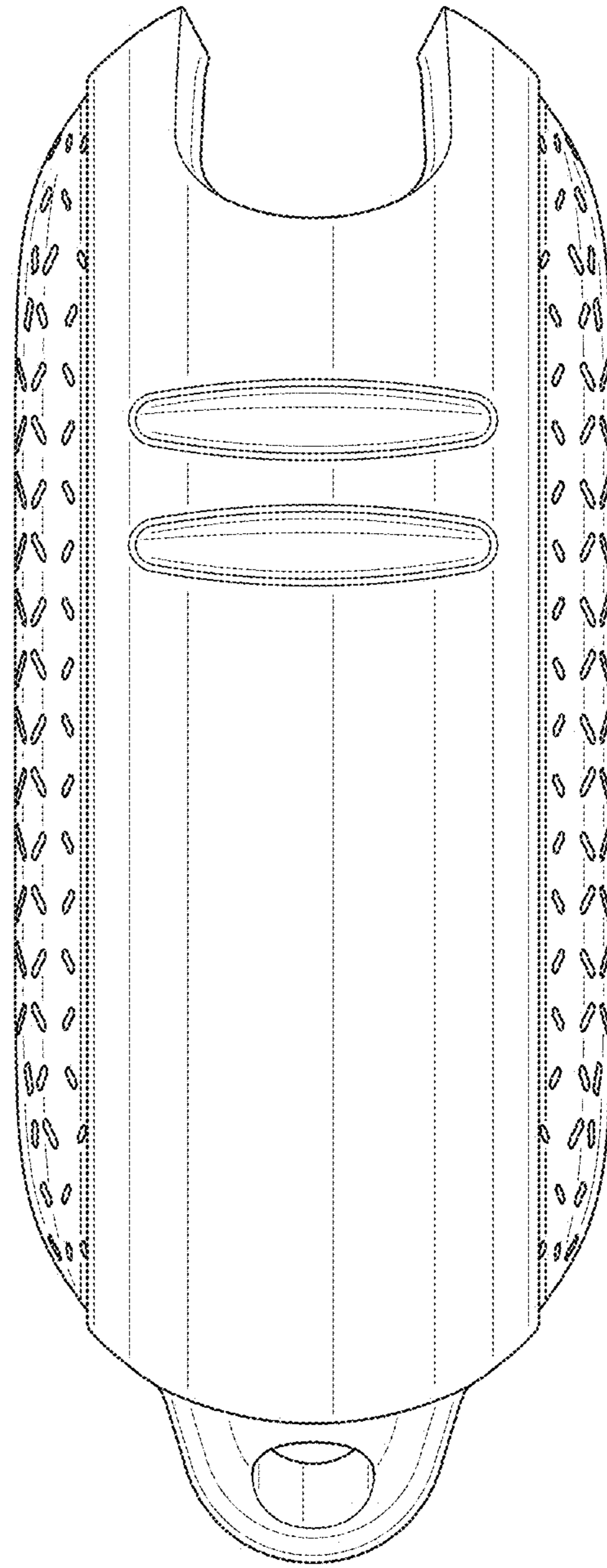

FIG. 46

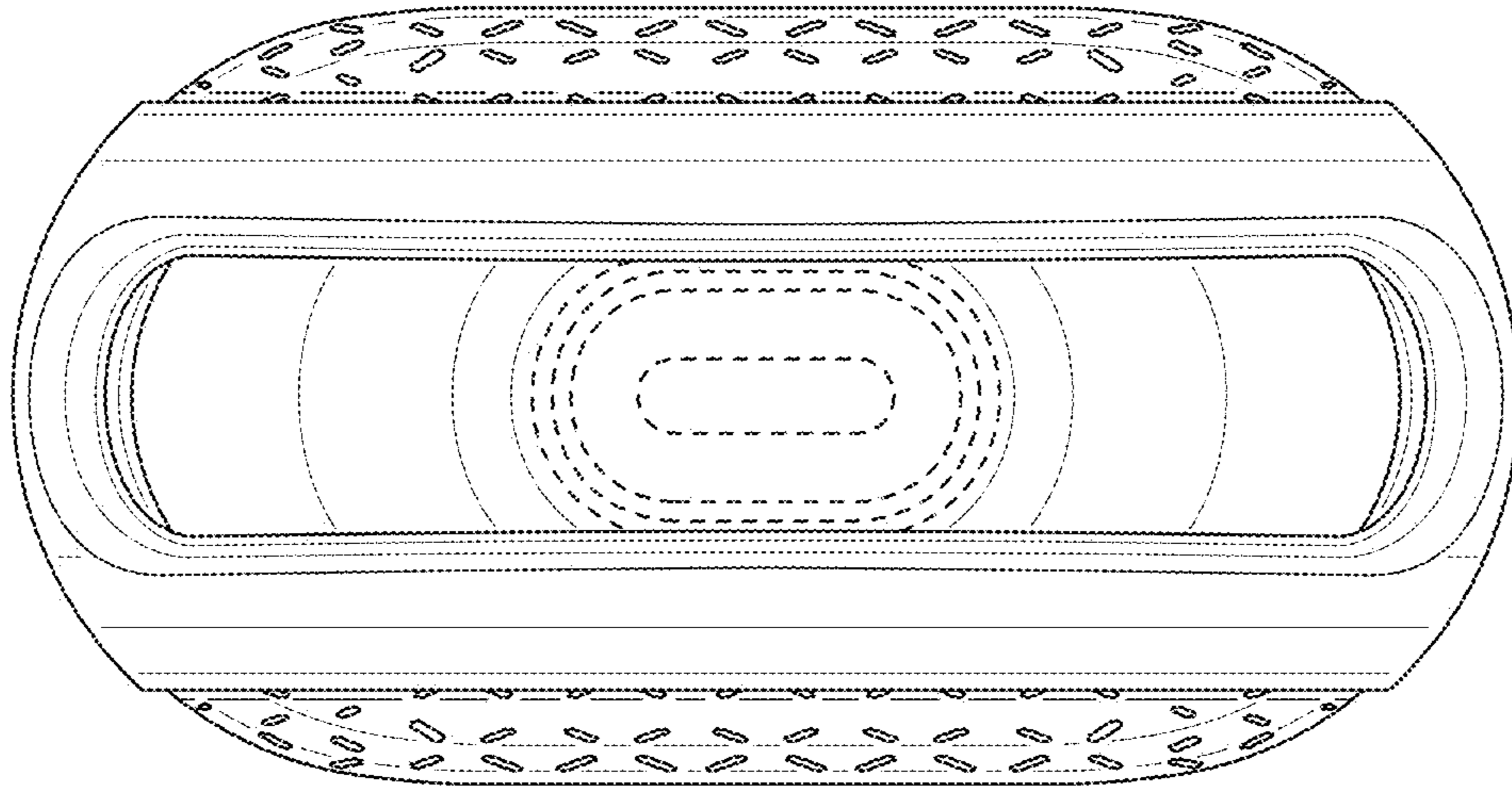

FIG. 47

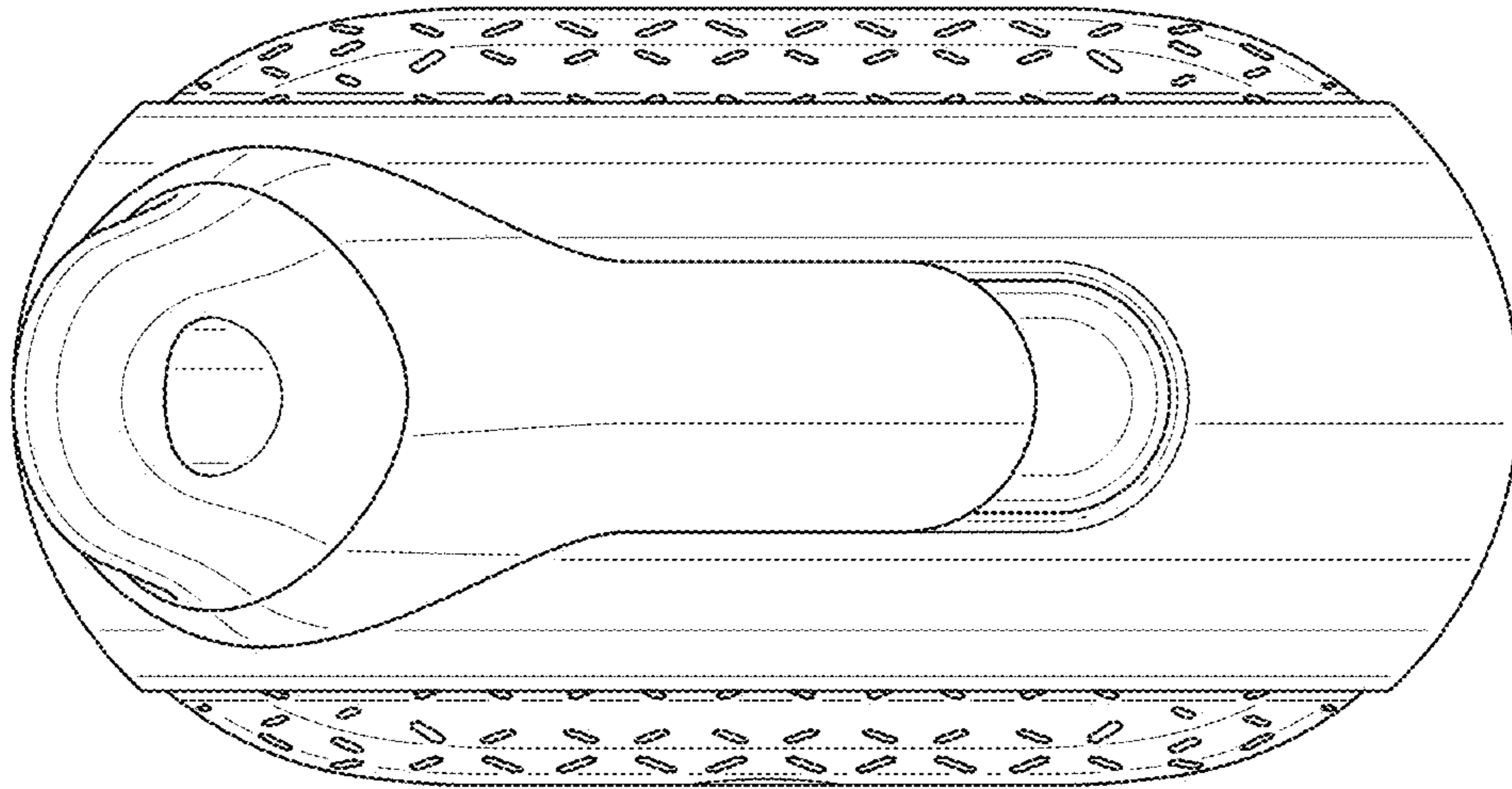

FIG. 48

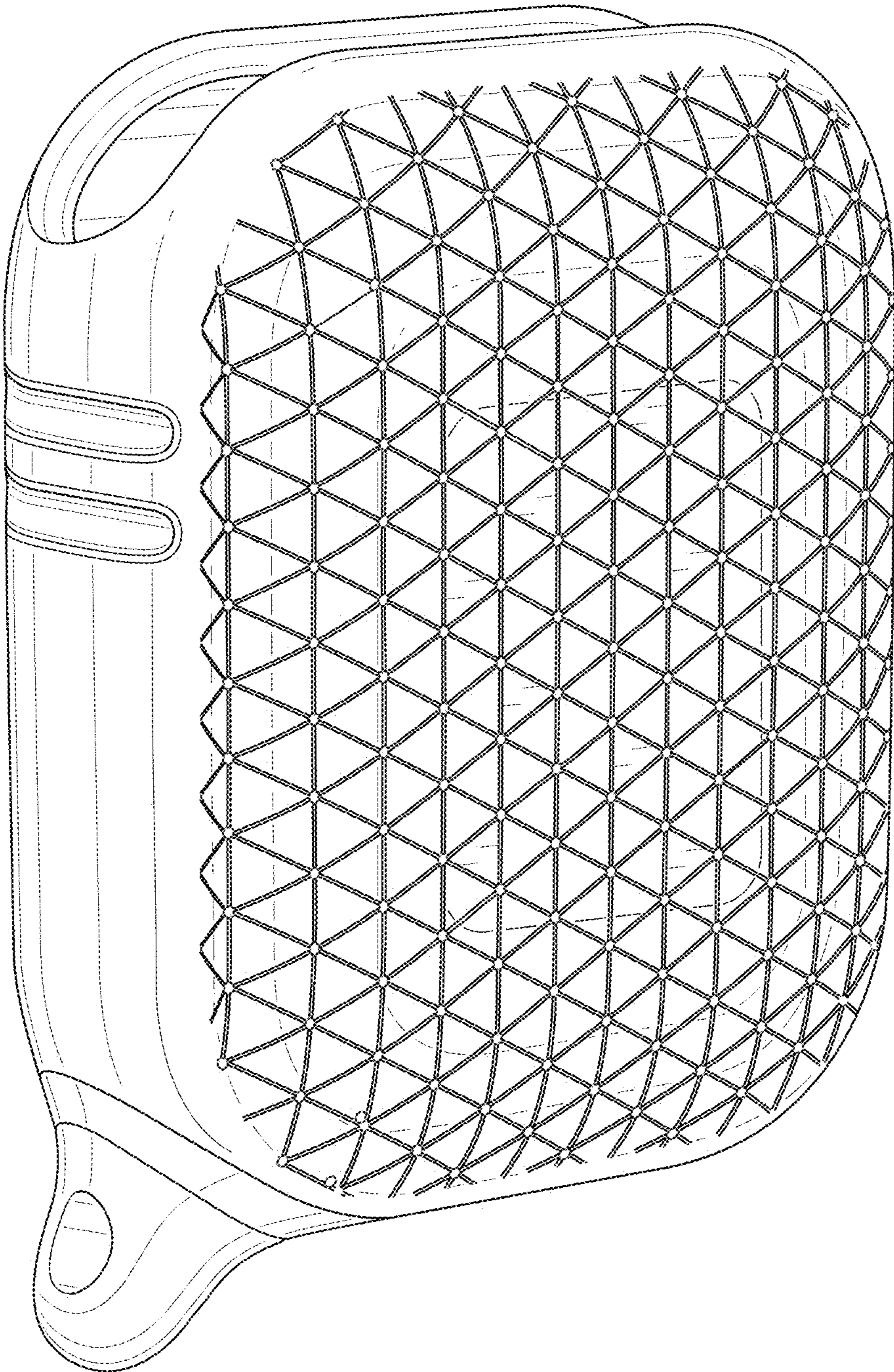

FIG. 49

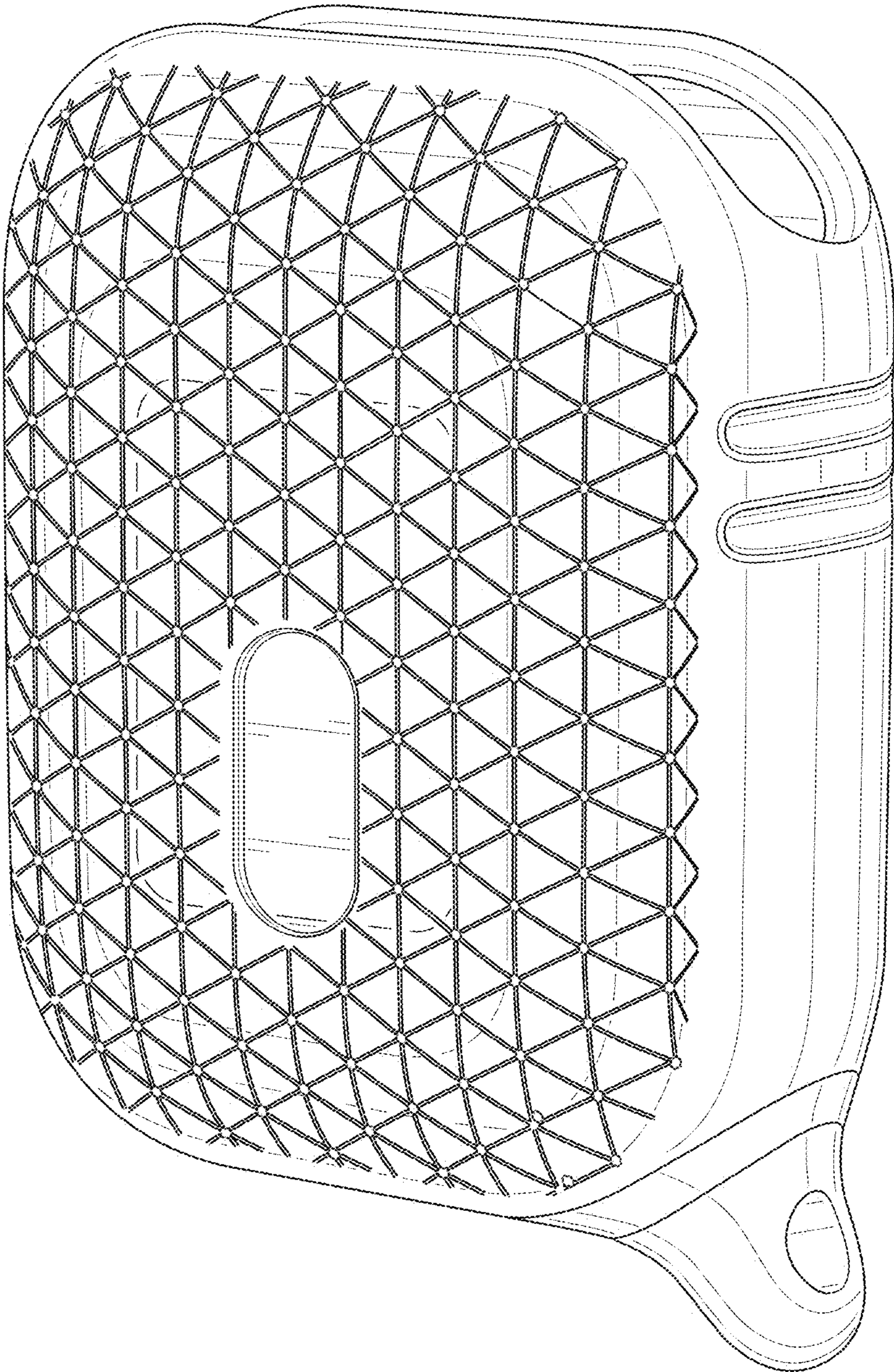

FIG. 50

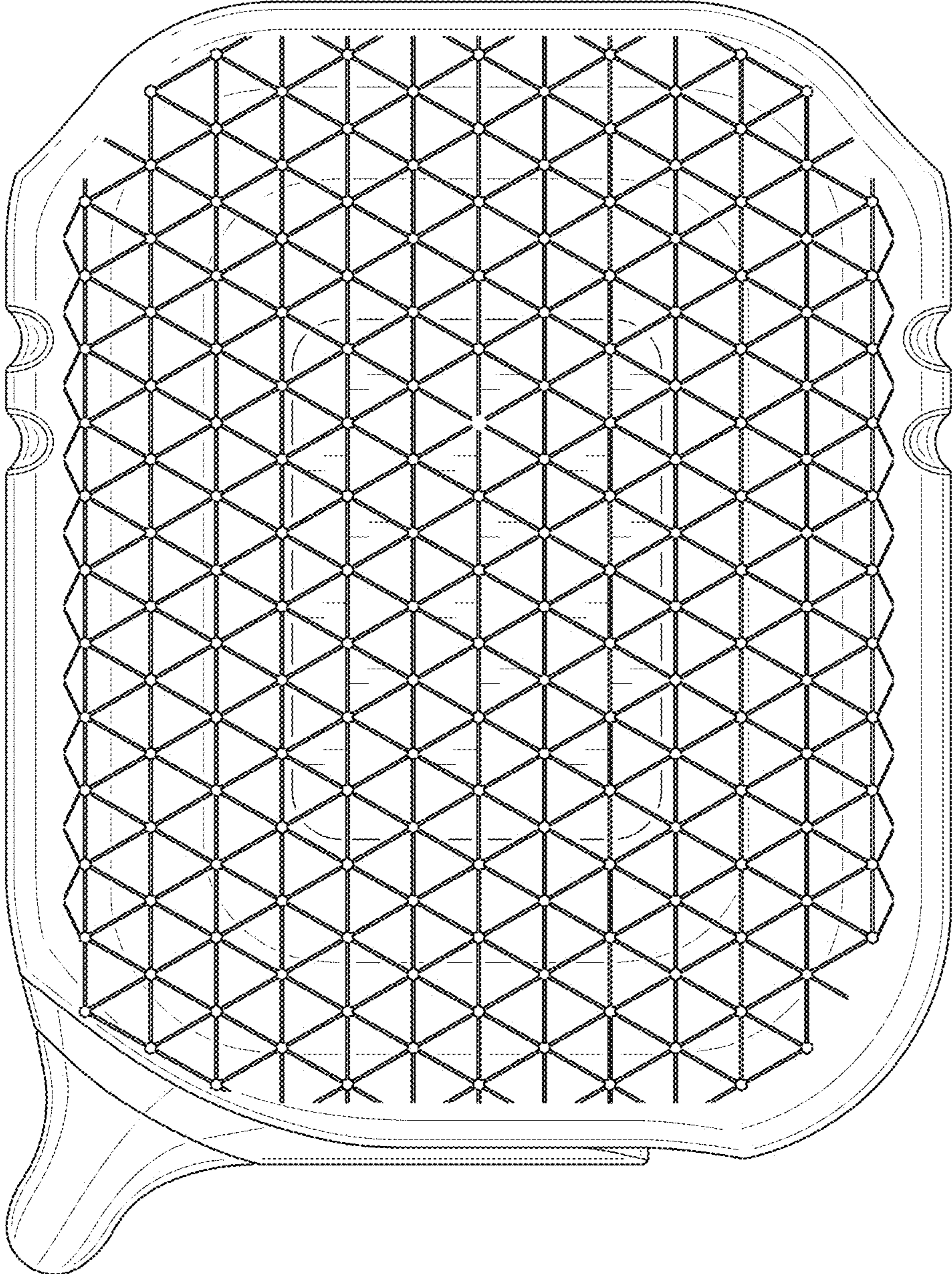

FIG. 51

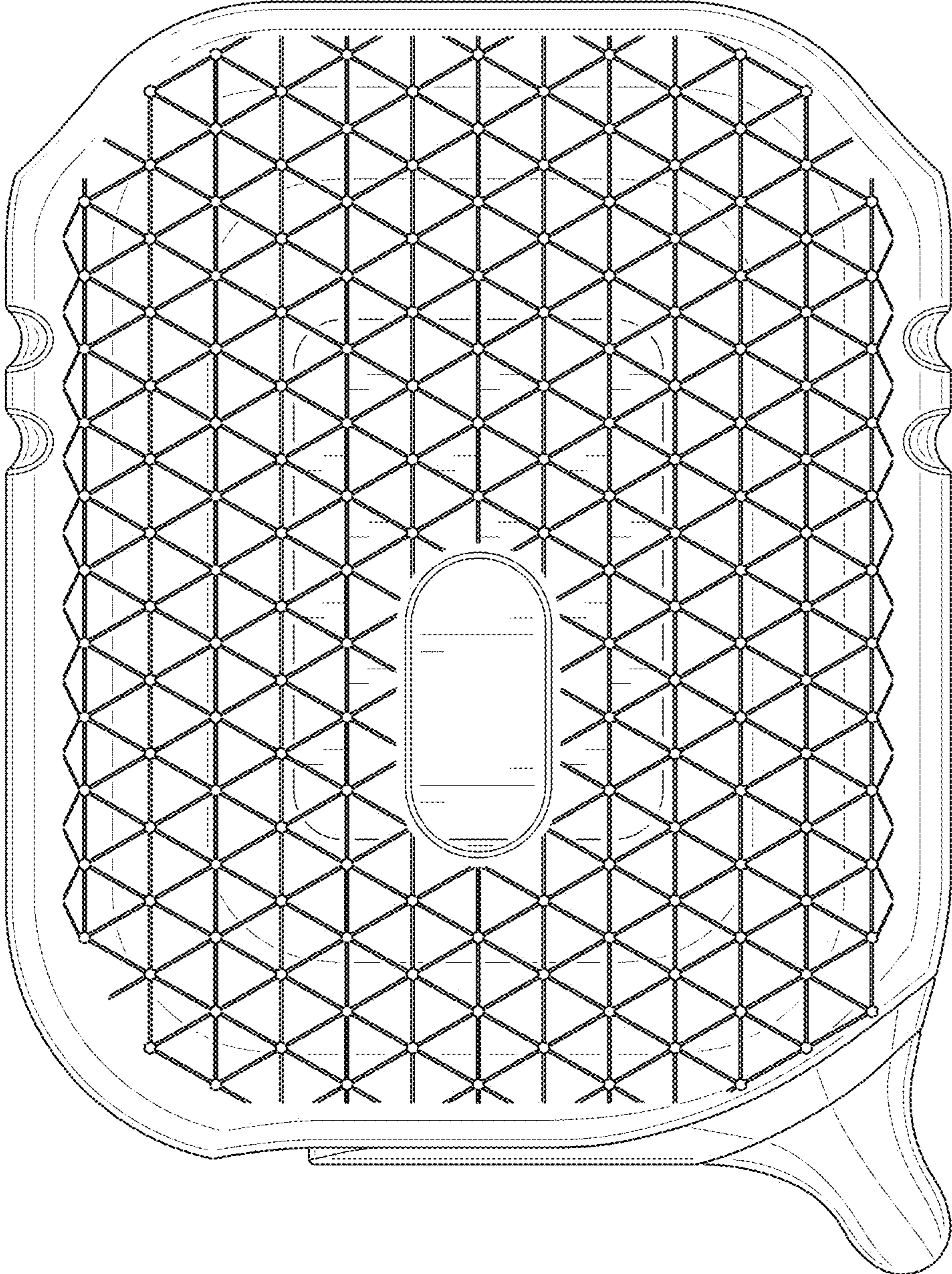

FIG. 52

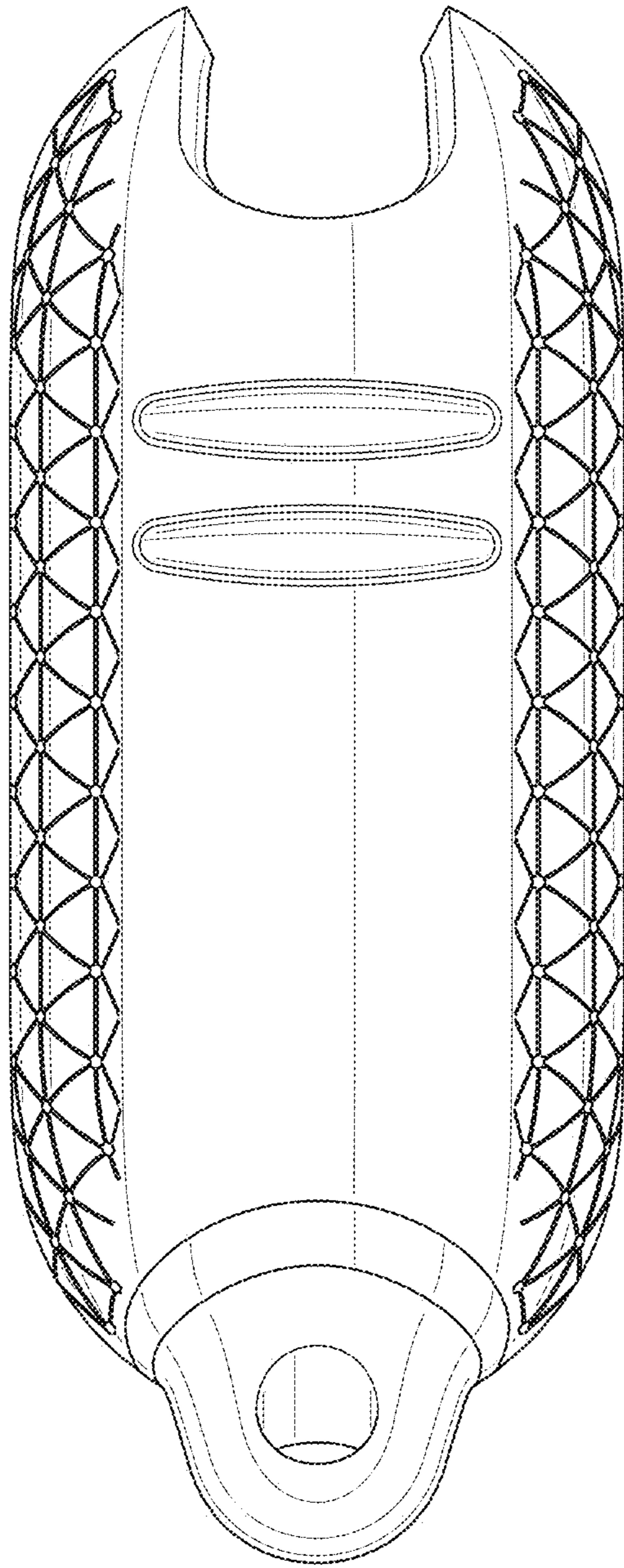

FIG. 53

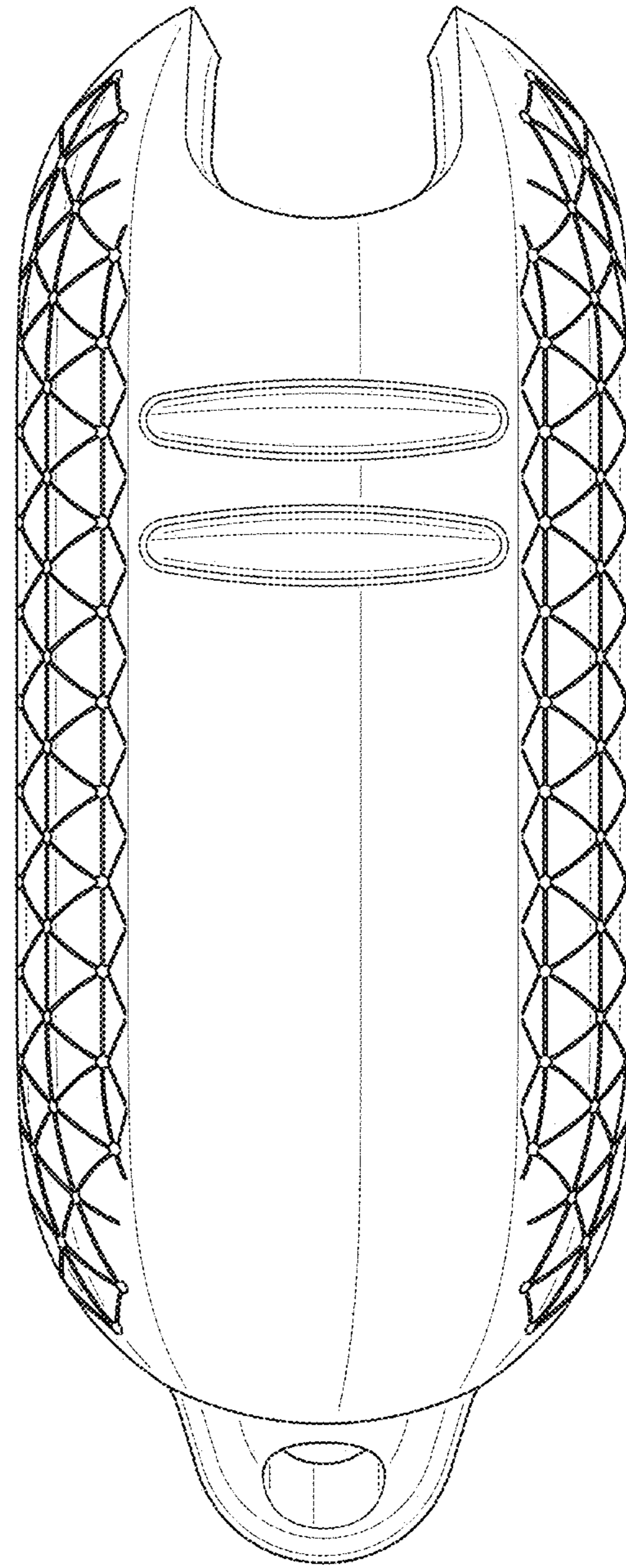

FIG. 54

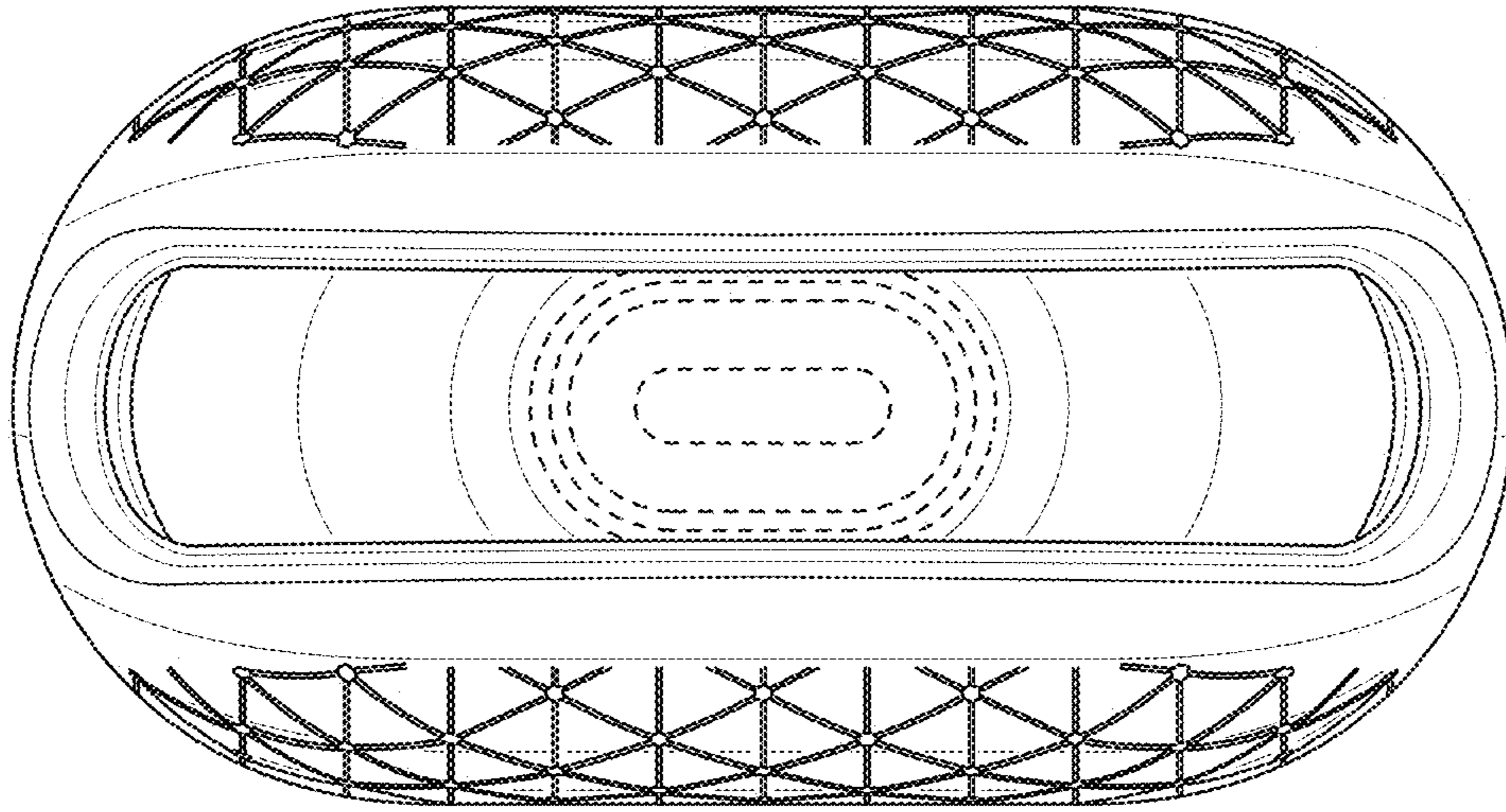

FIG. 55

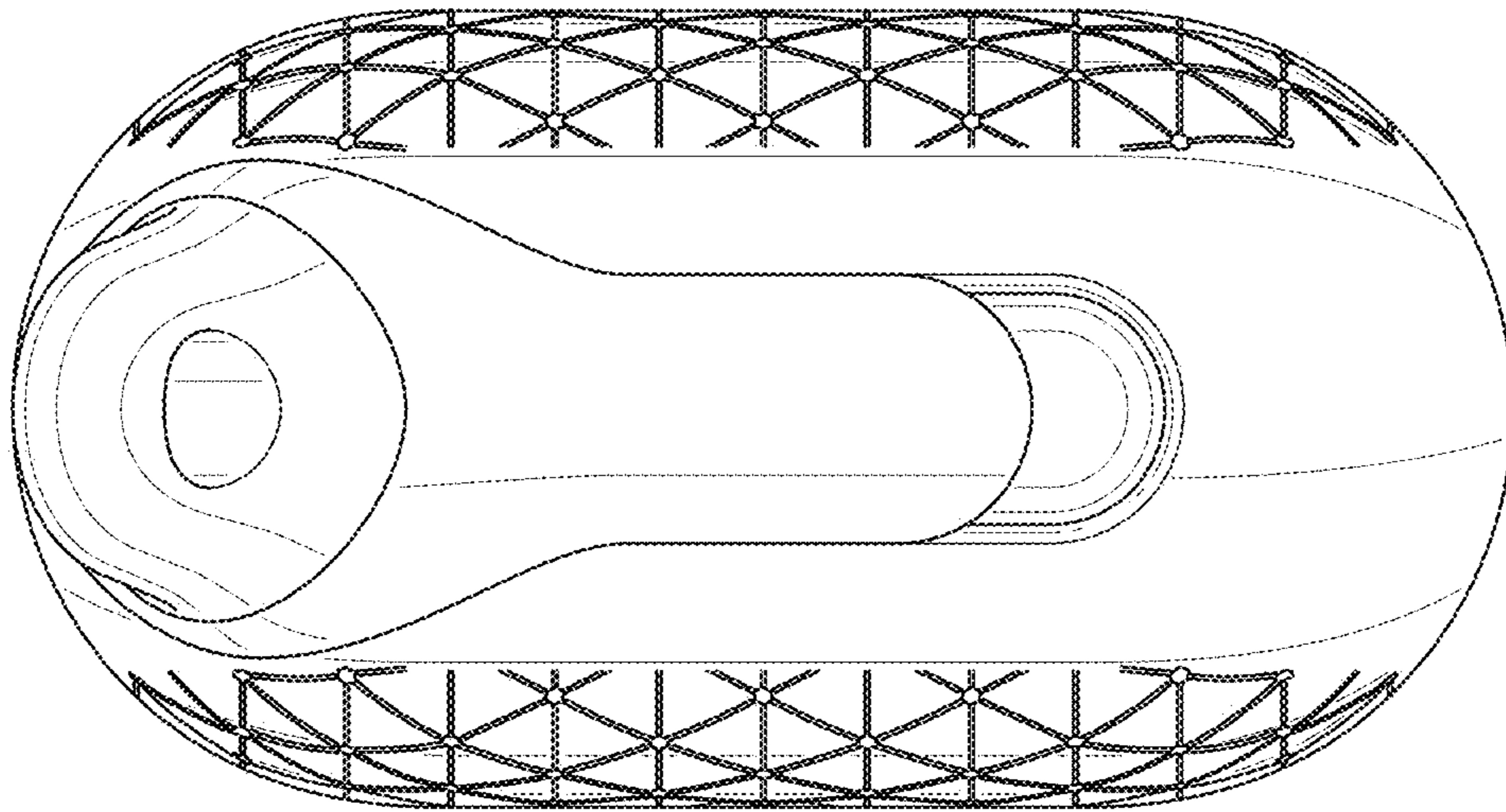

FIG. 56

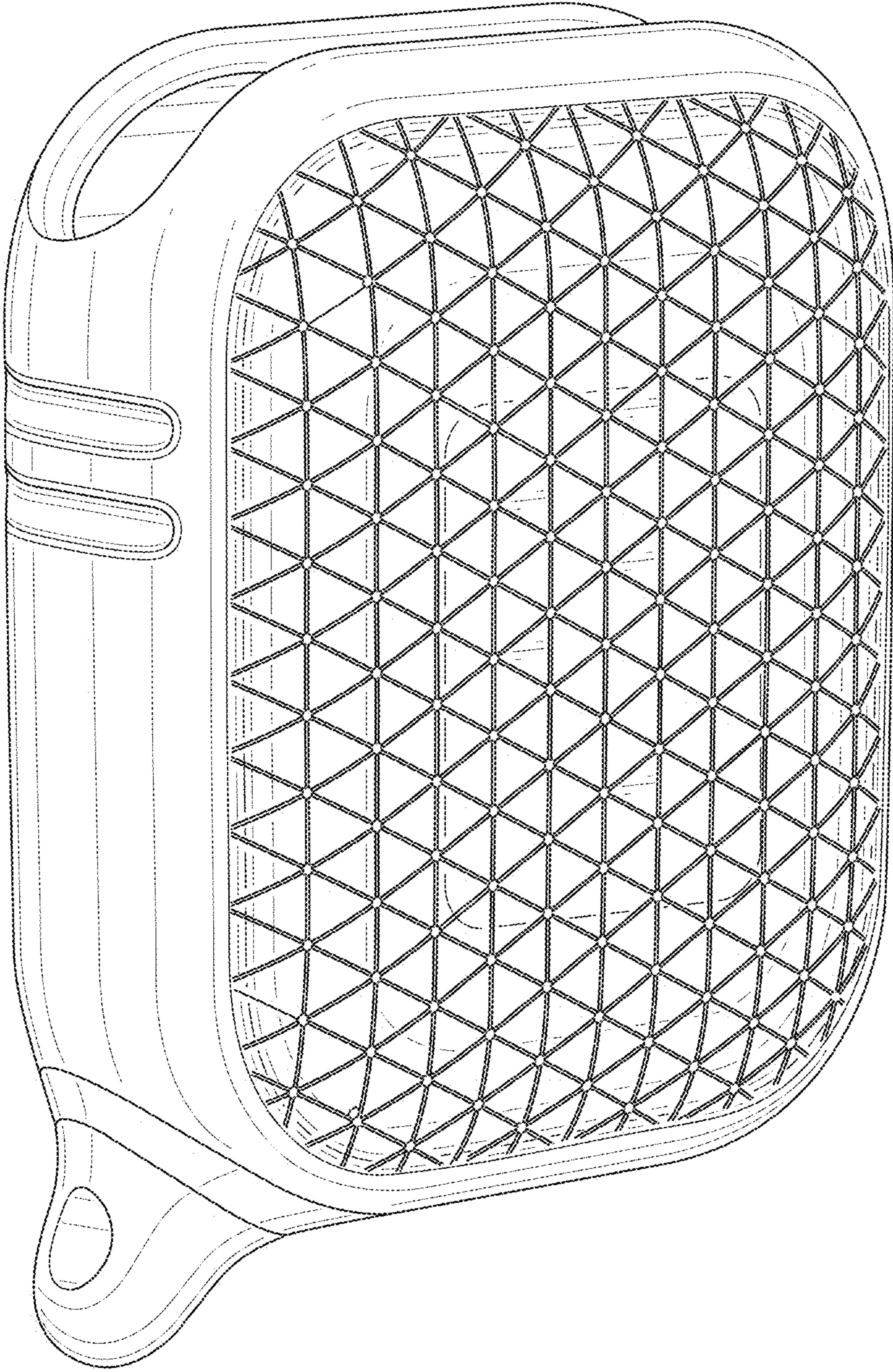

FIG. 57

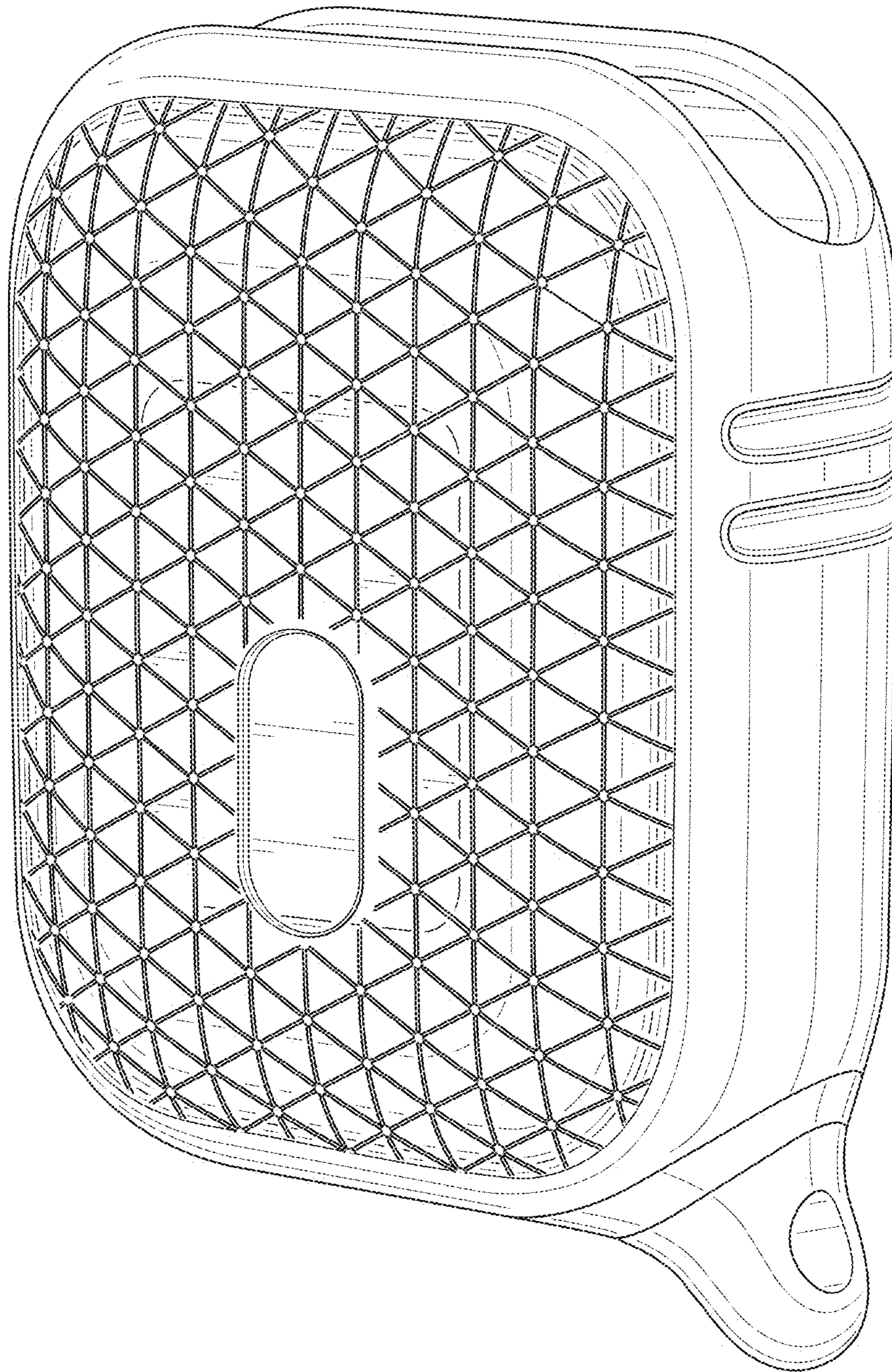

FIG. 58

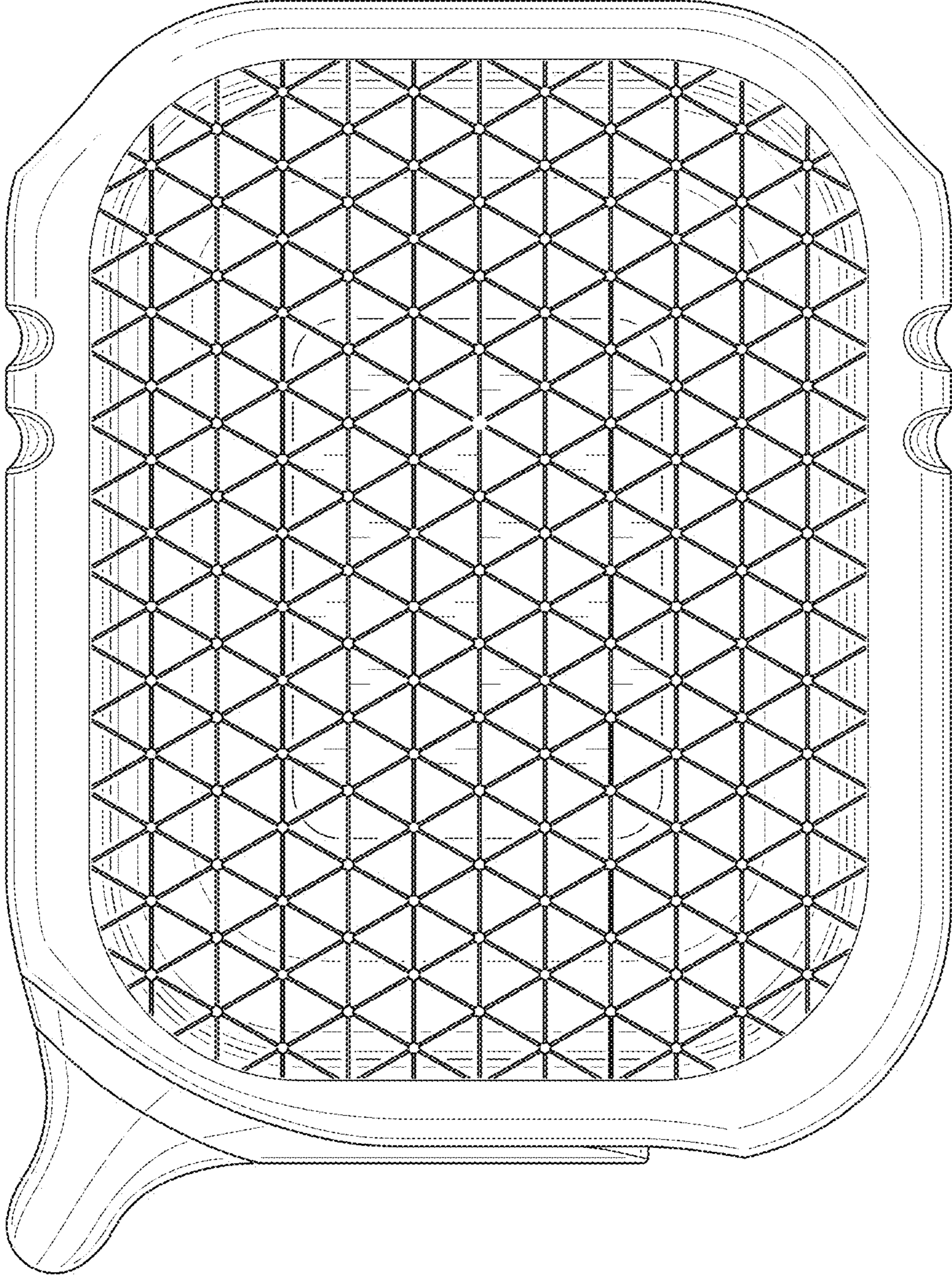

FIG. 59

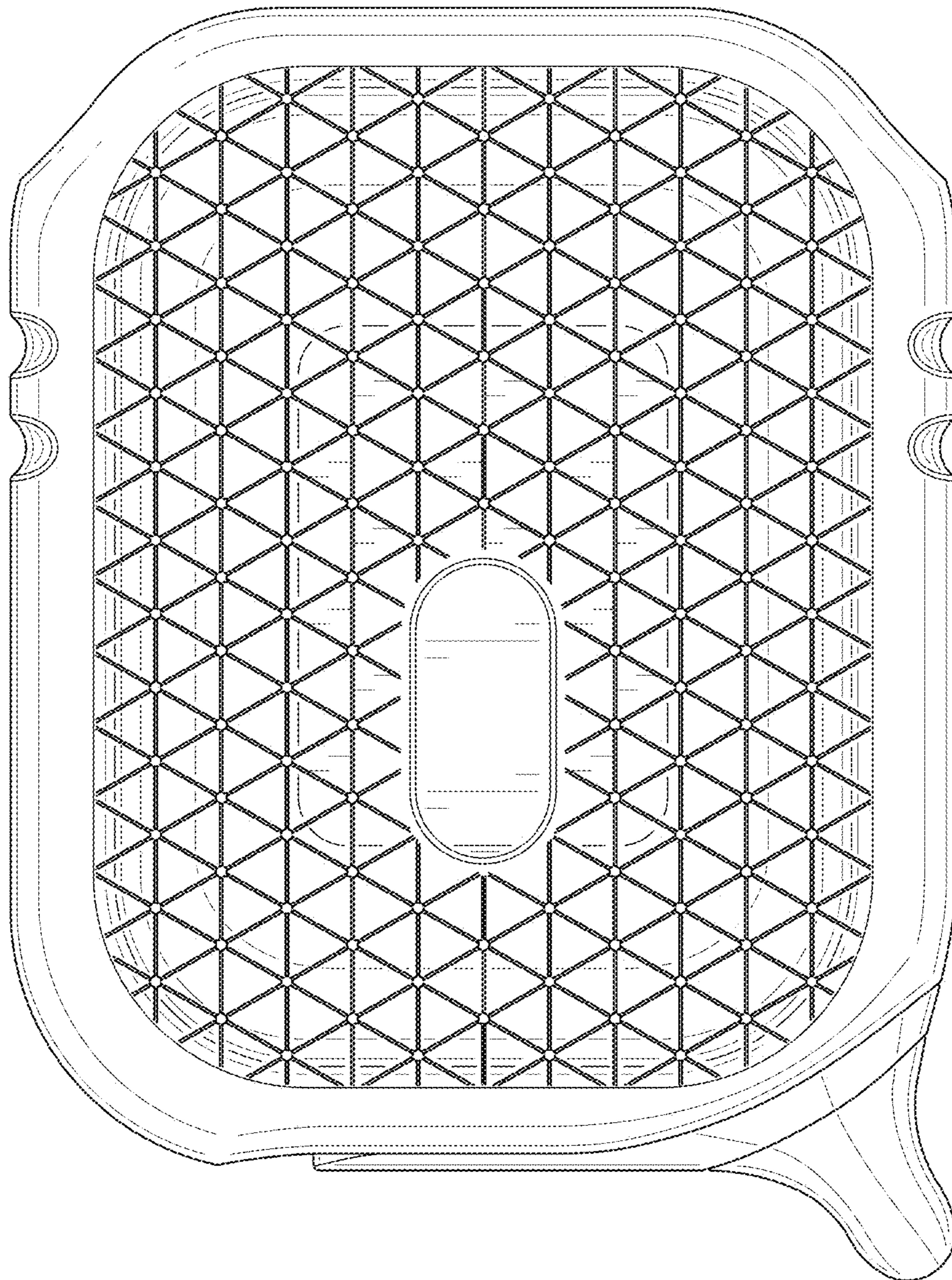

FIG. 60

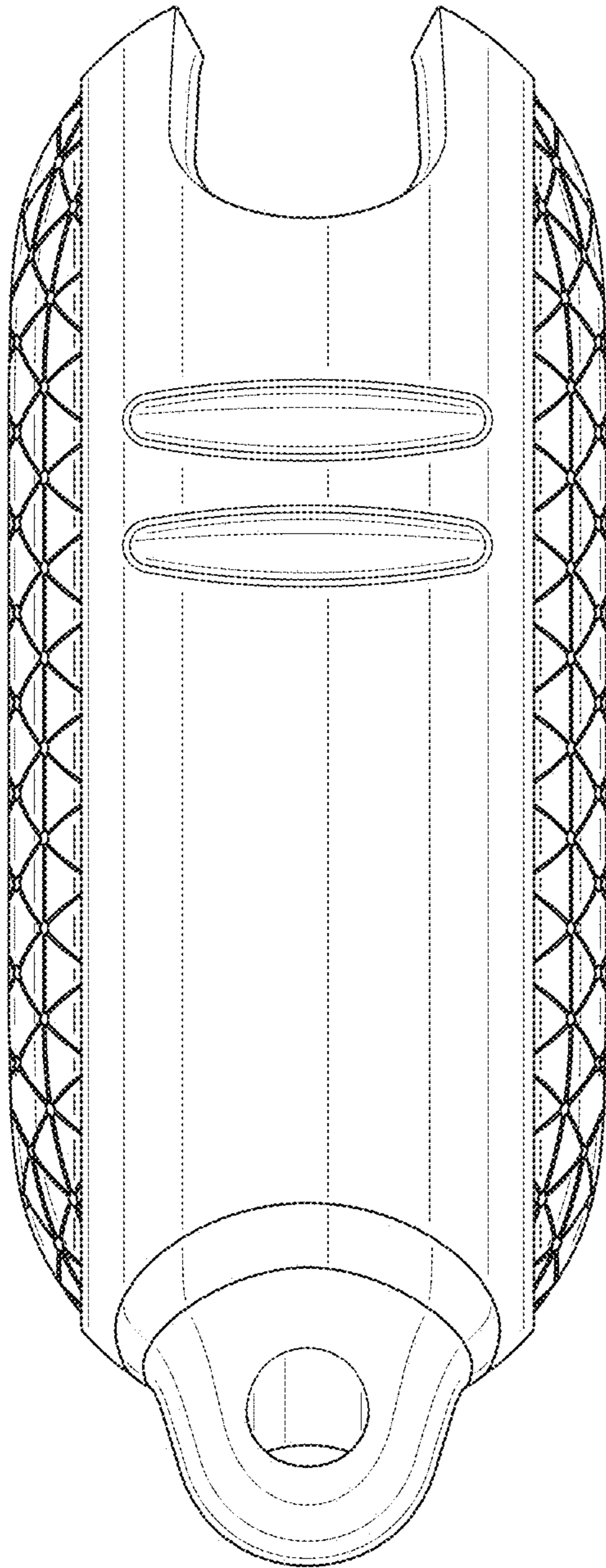

FIG. 61

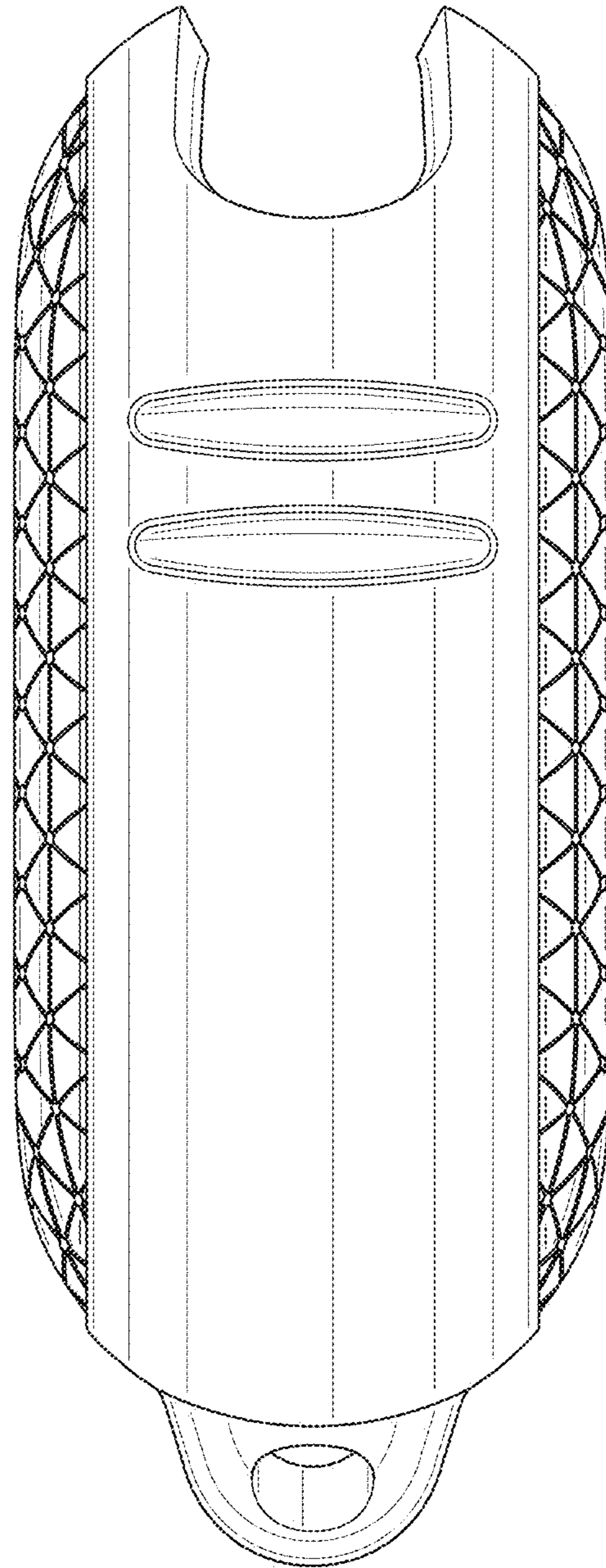

FIG. 62

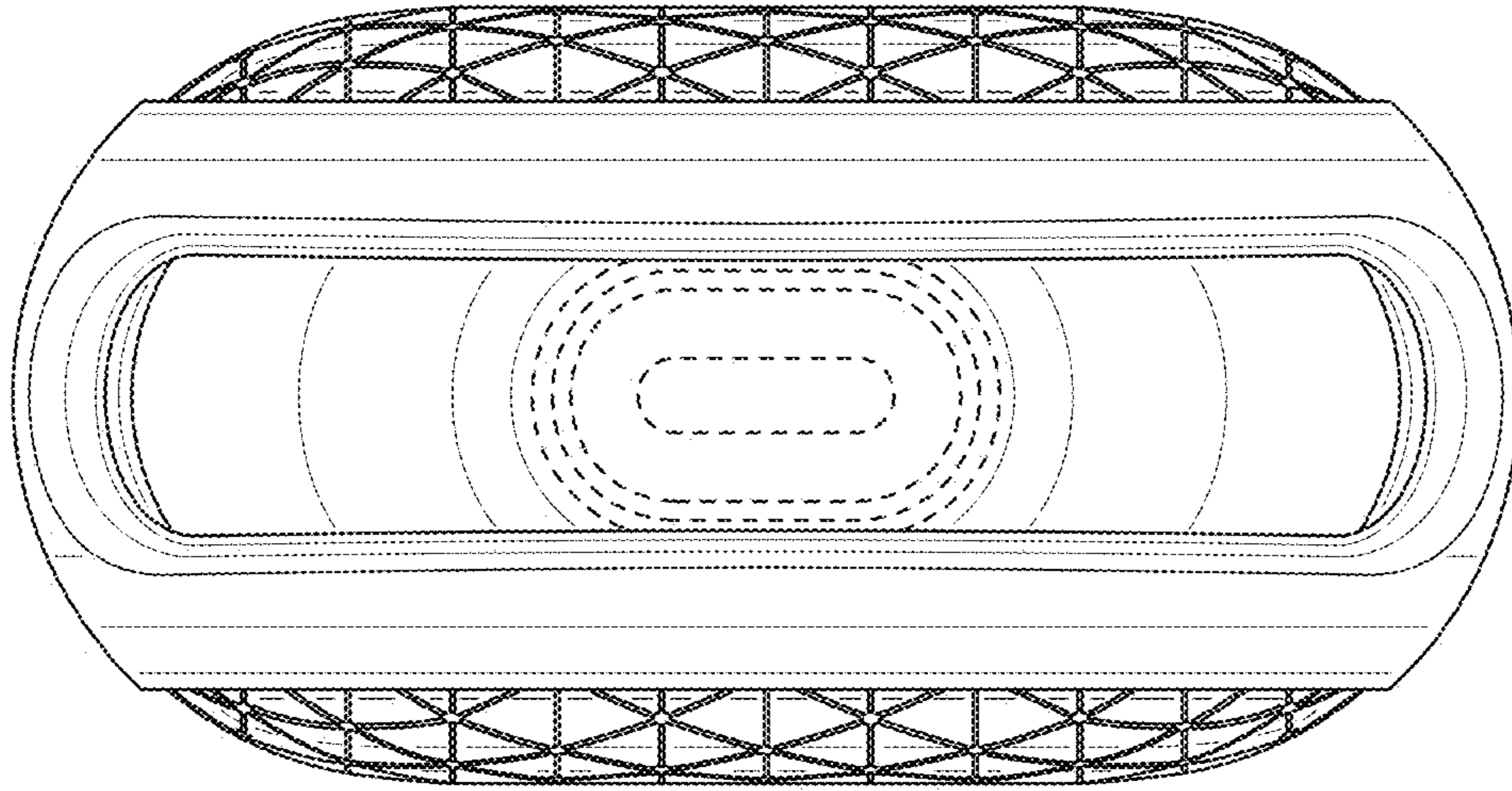

FIG. 63

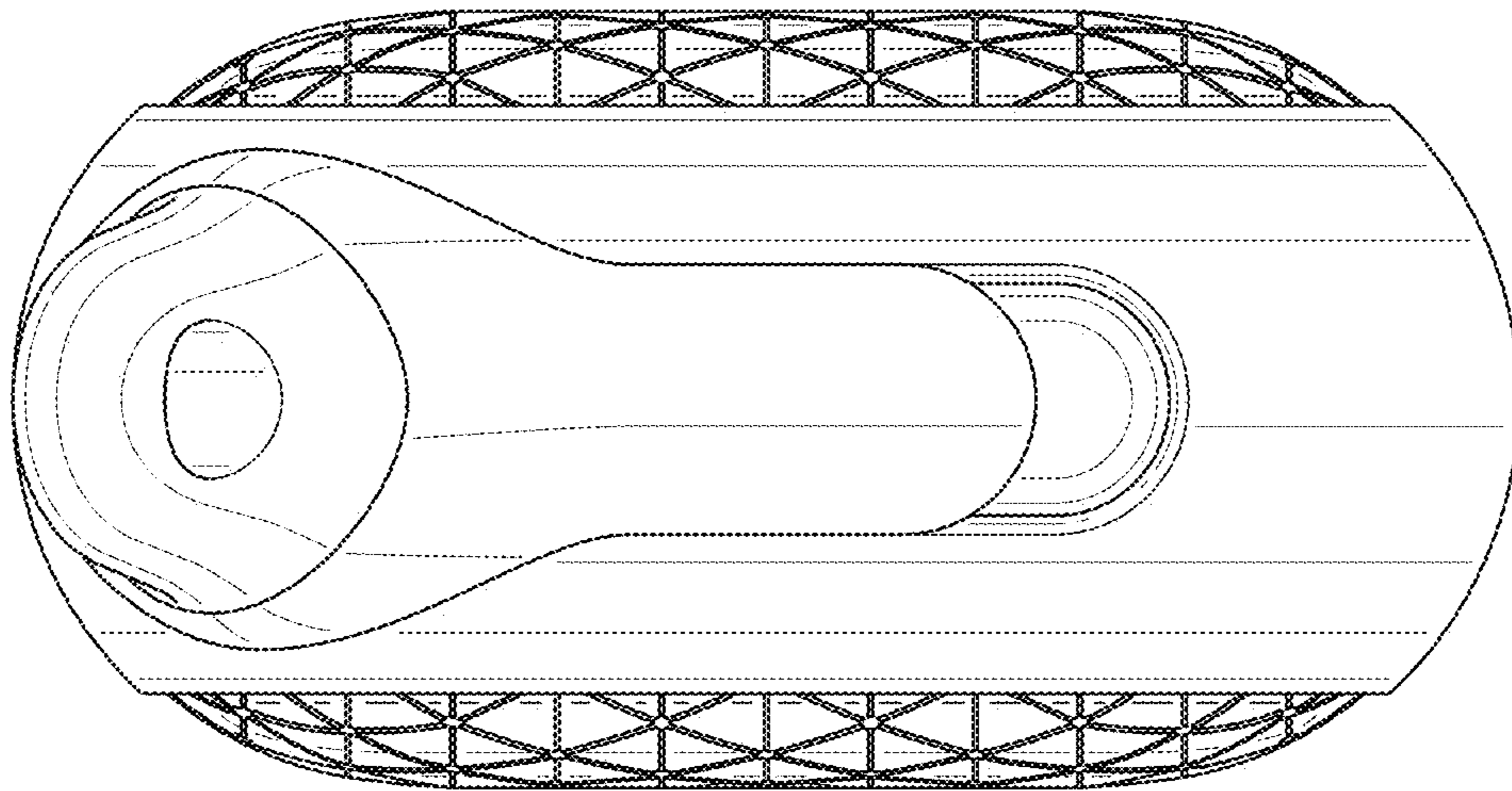

FIG. 64

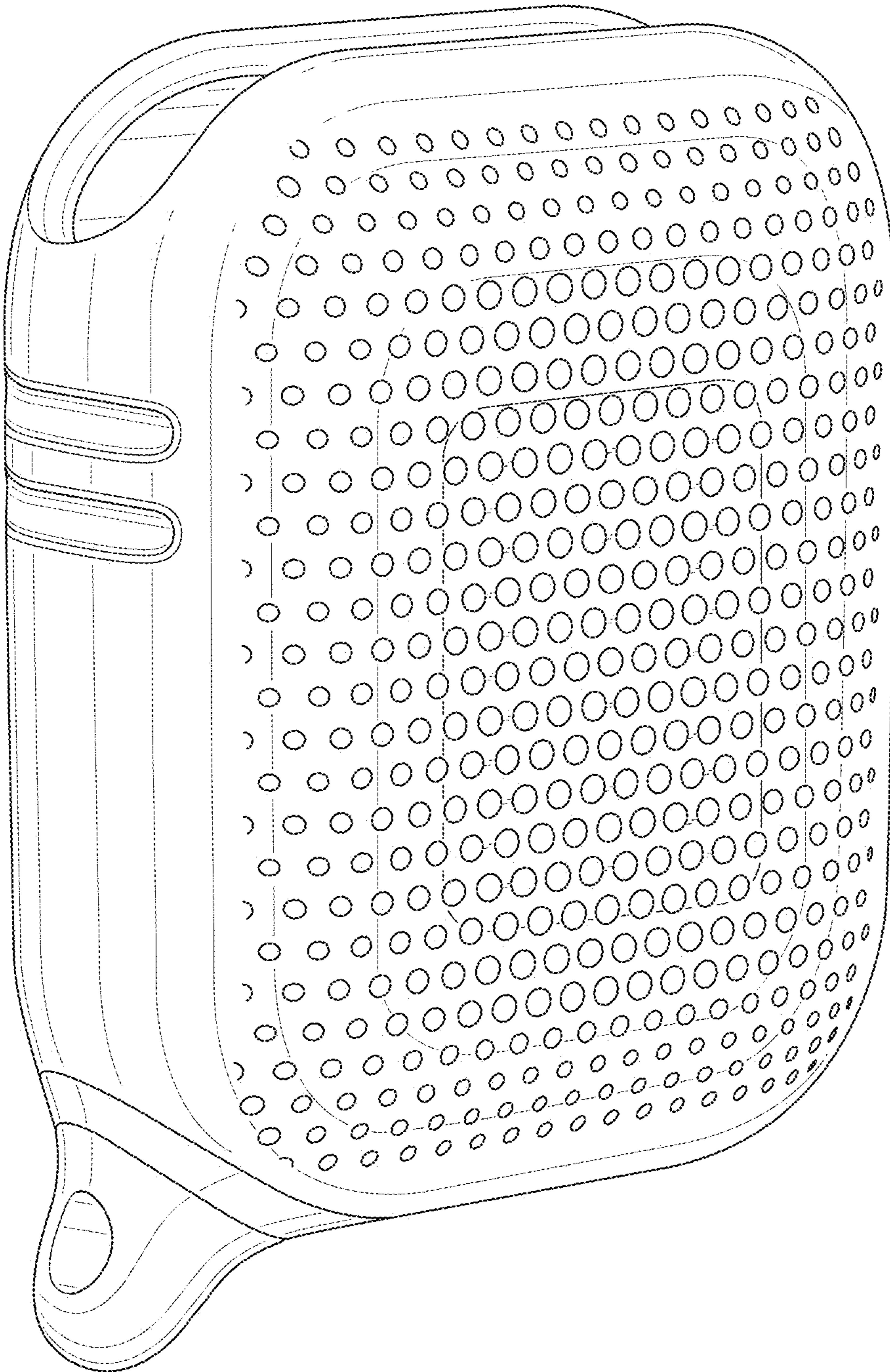

FIG. 65

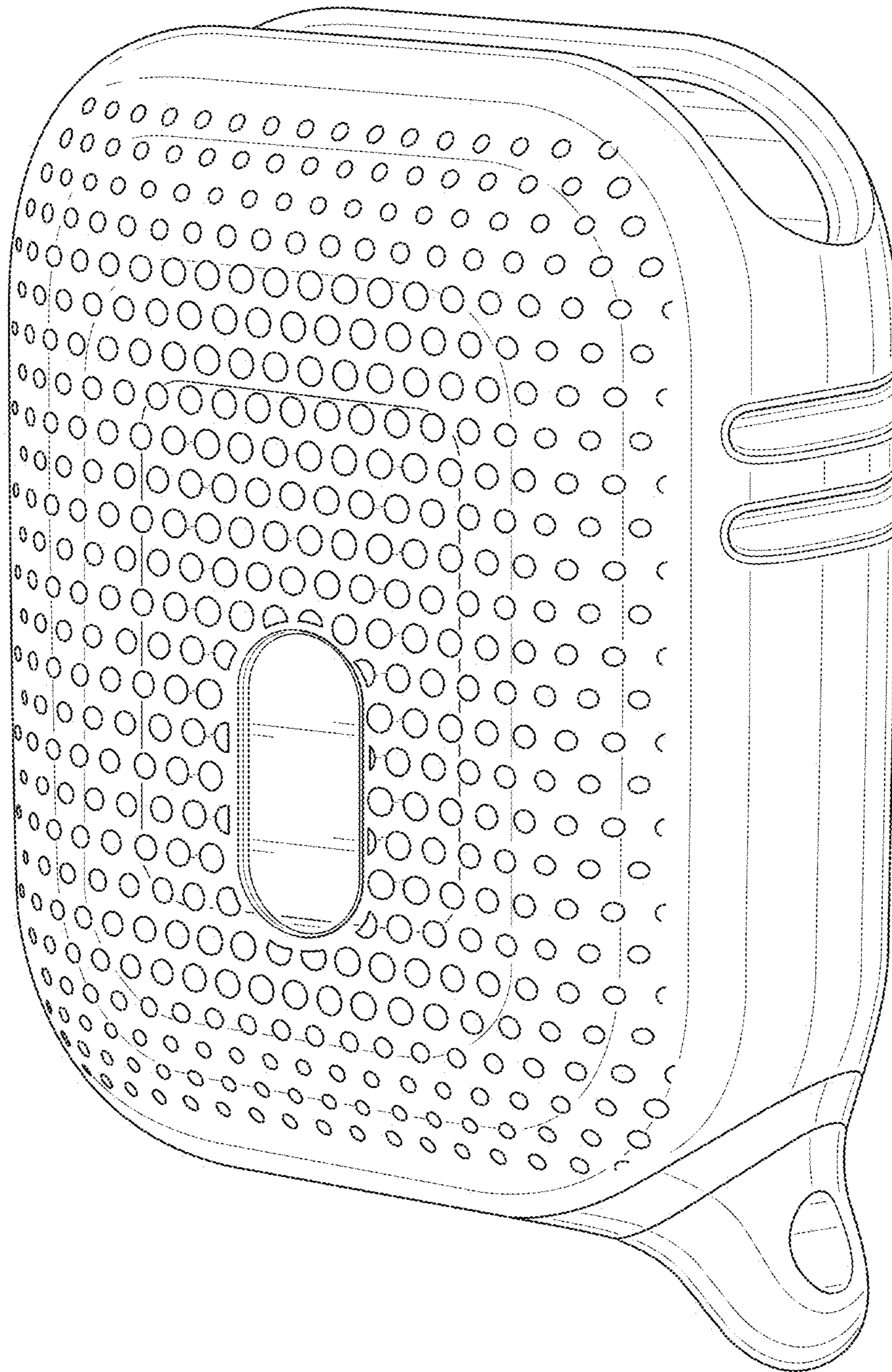

FIG. 66

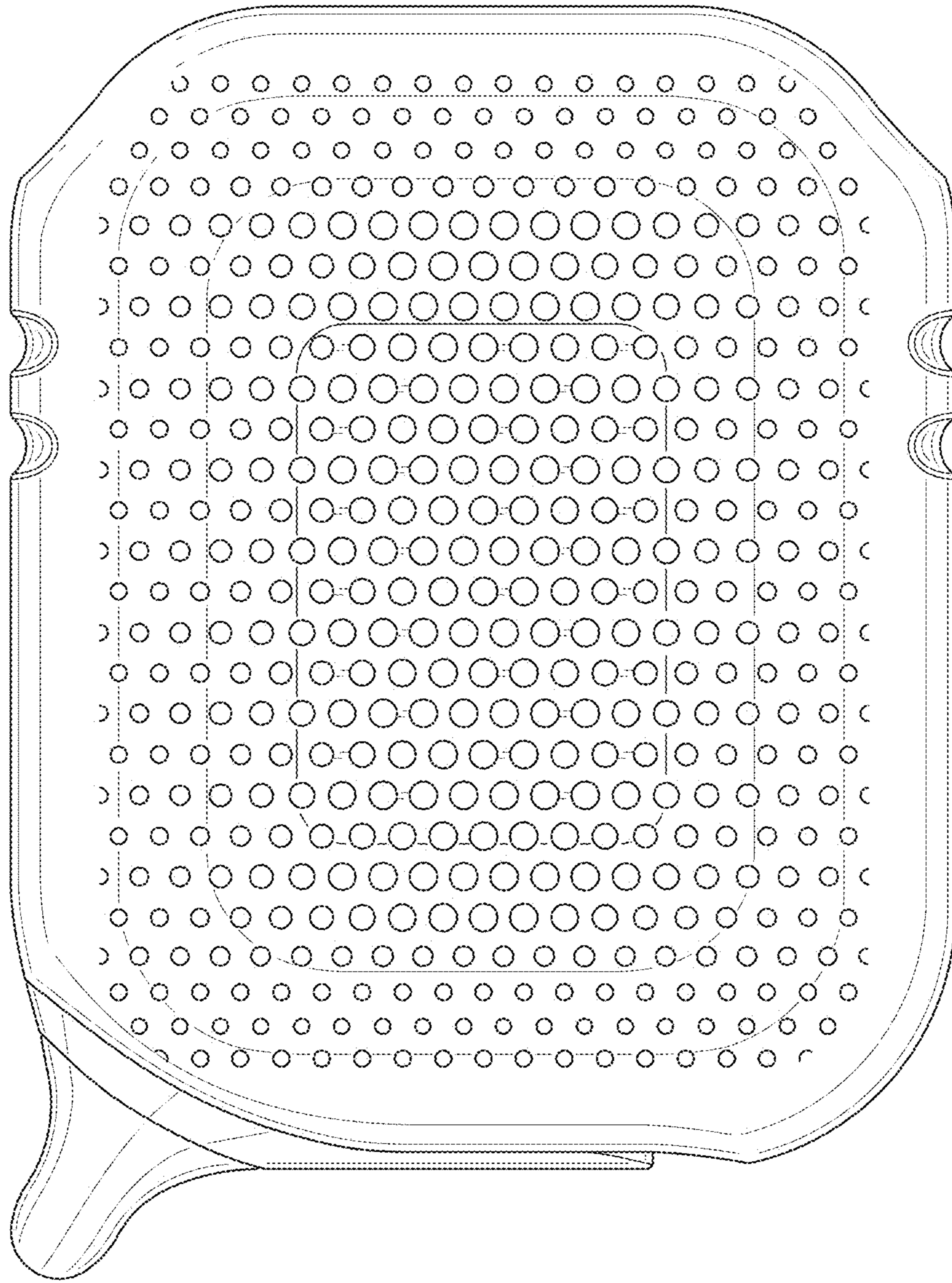

FIG. 67

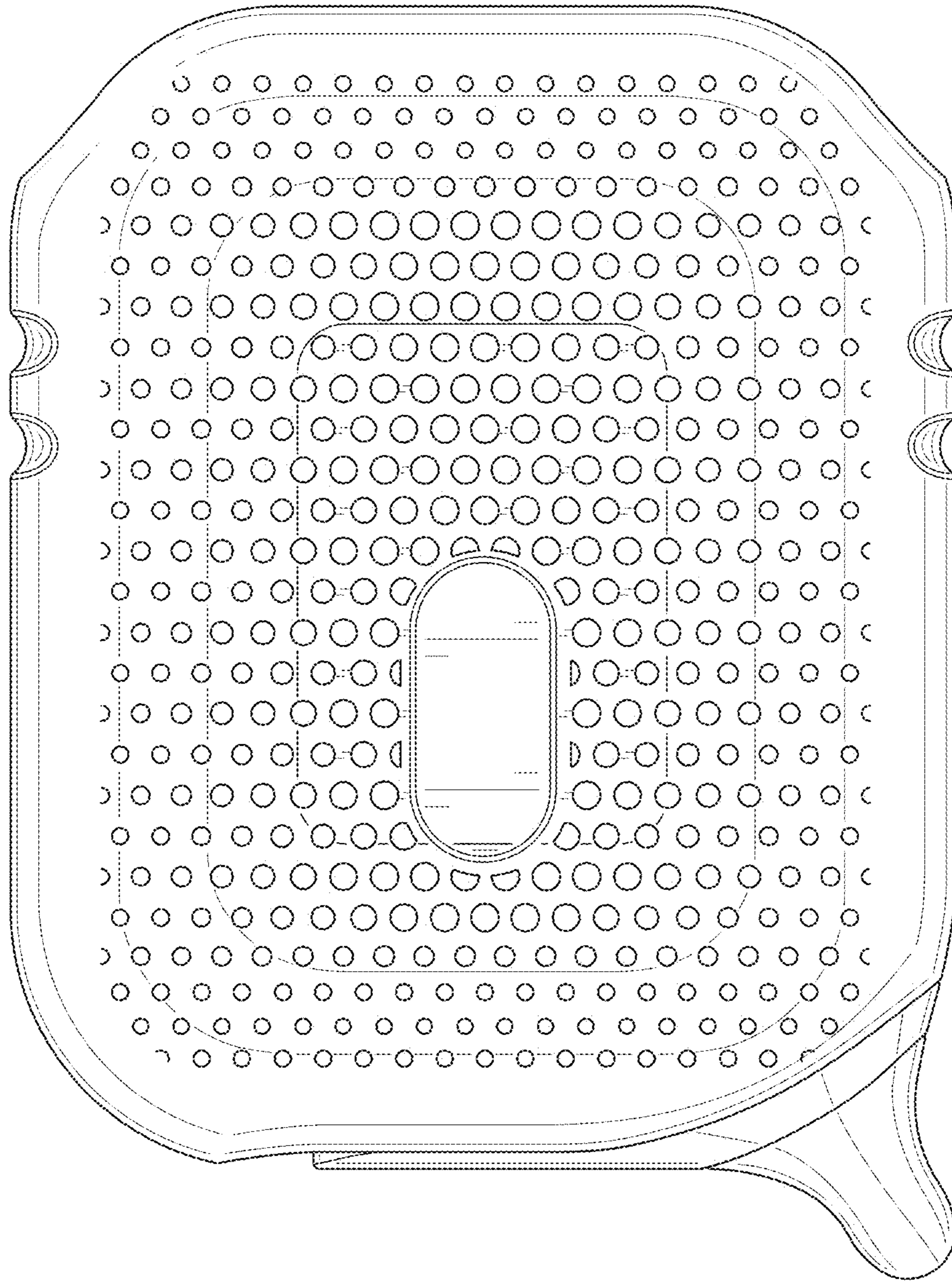

FIG. 68

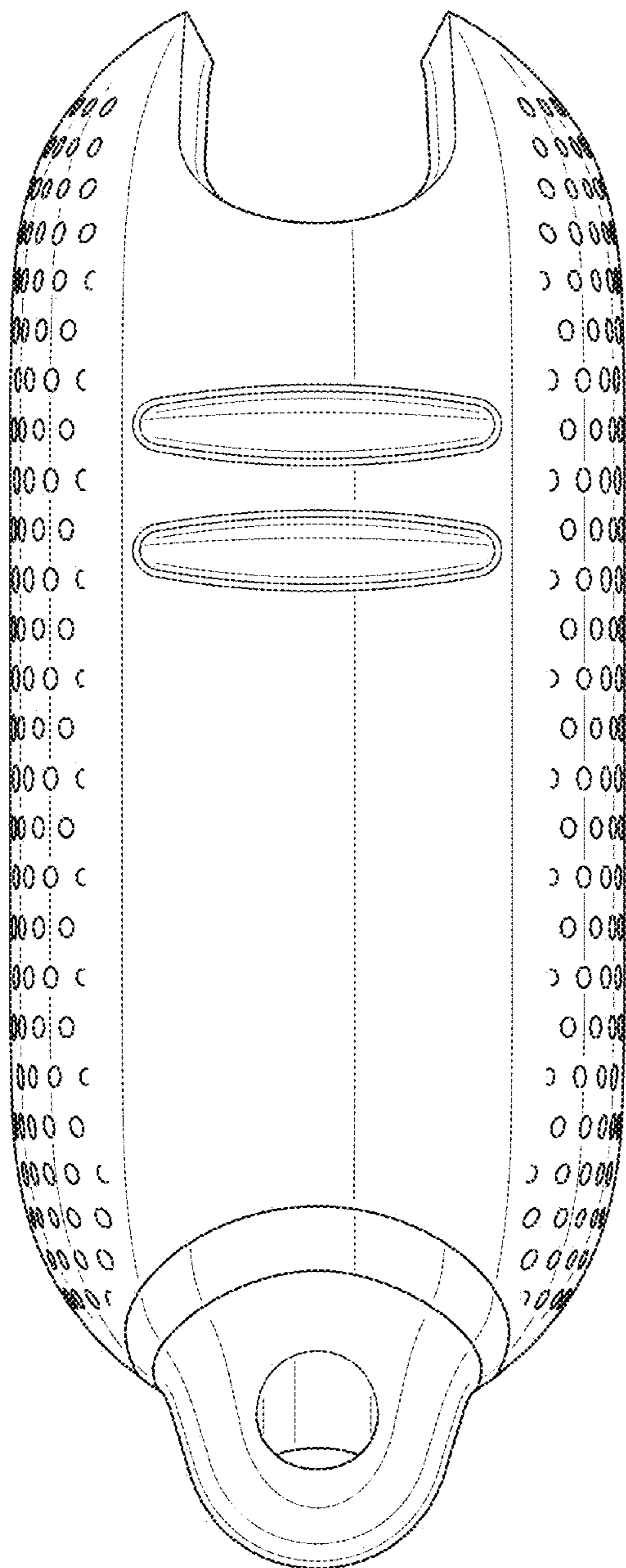

FIG. 69

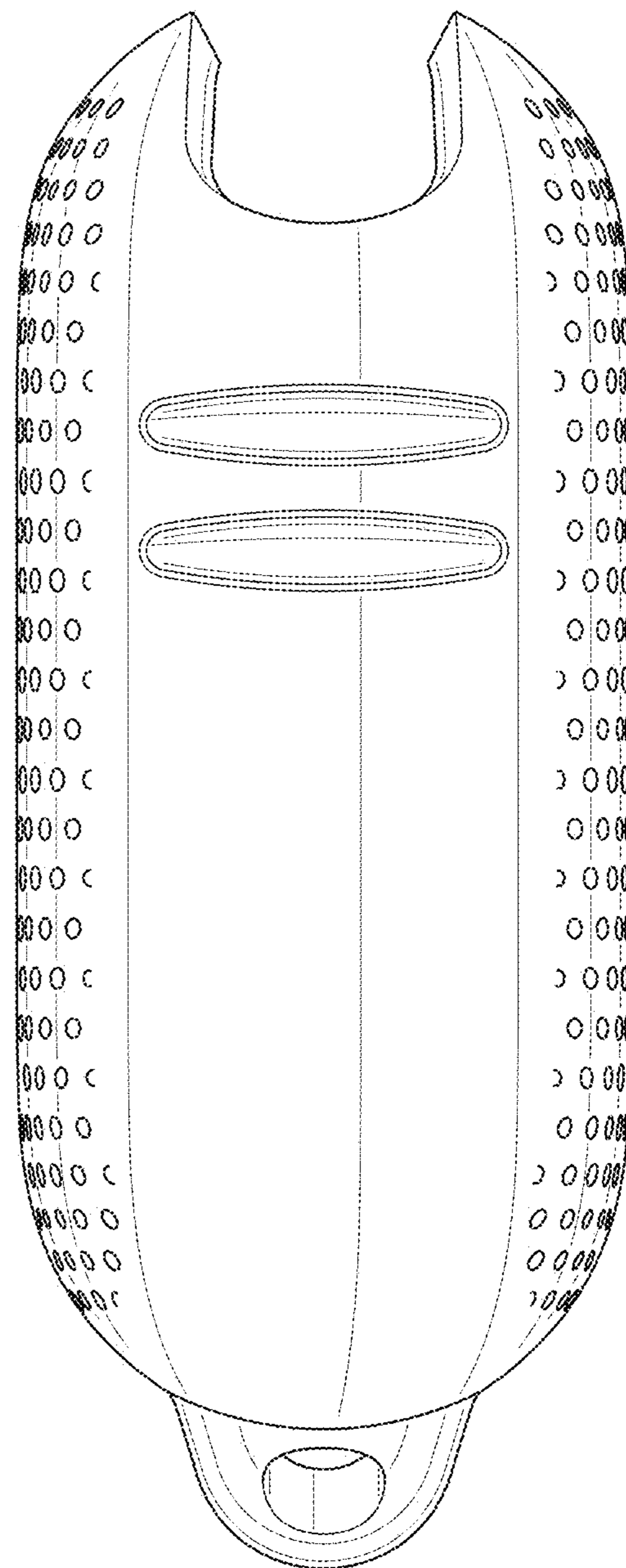

FIG. 70

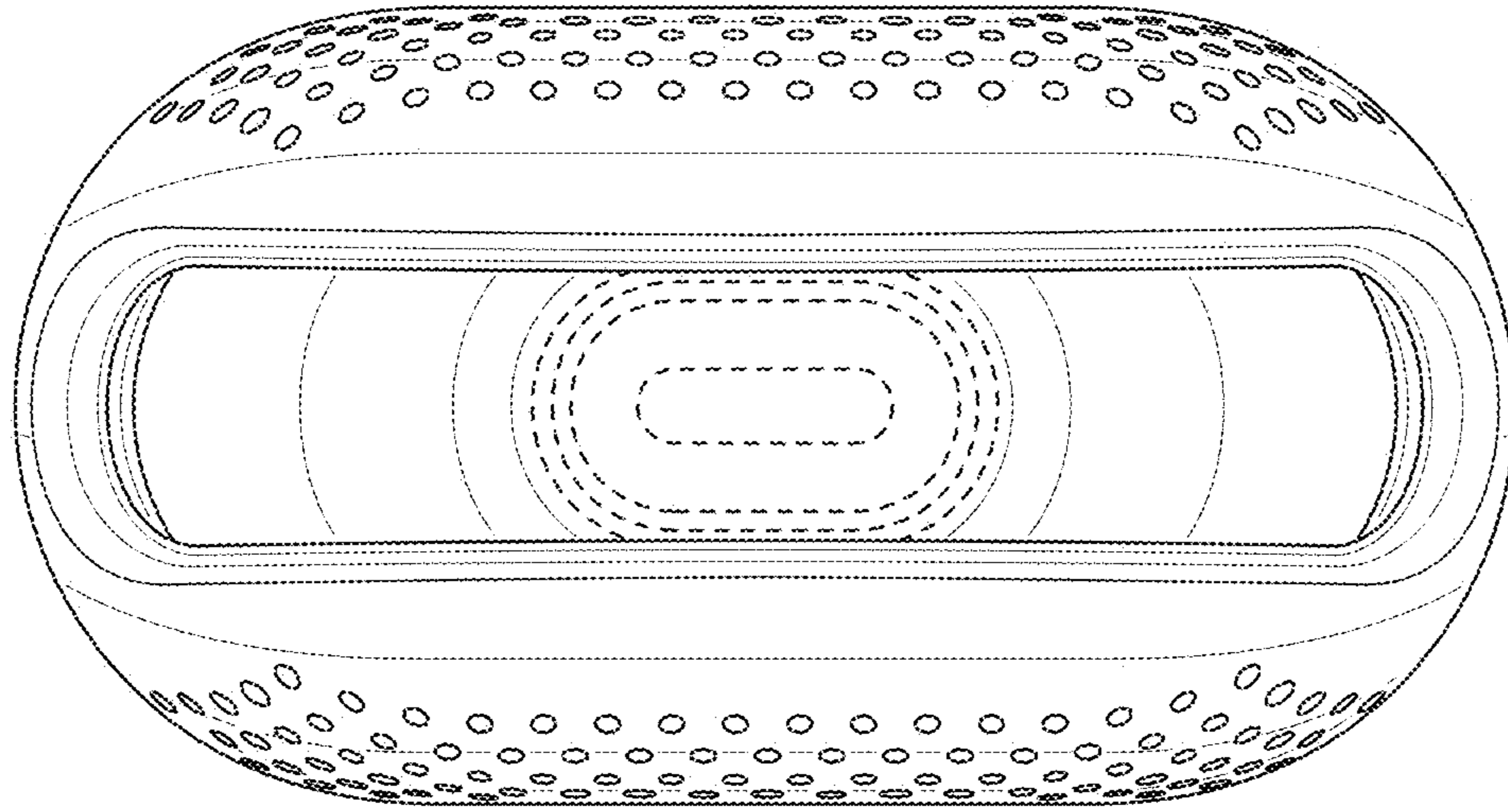

FIG. 71

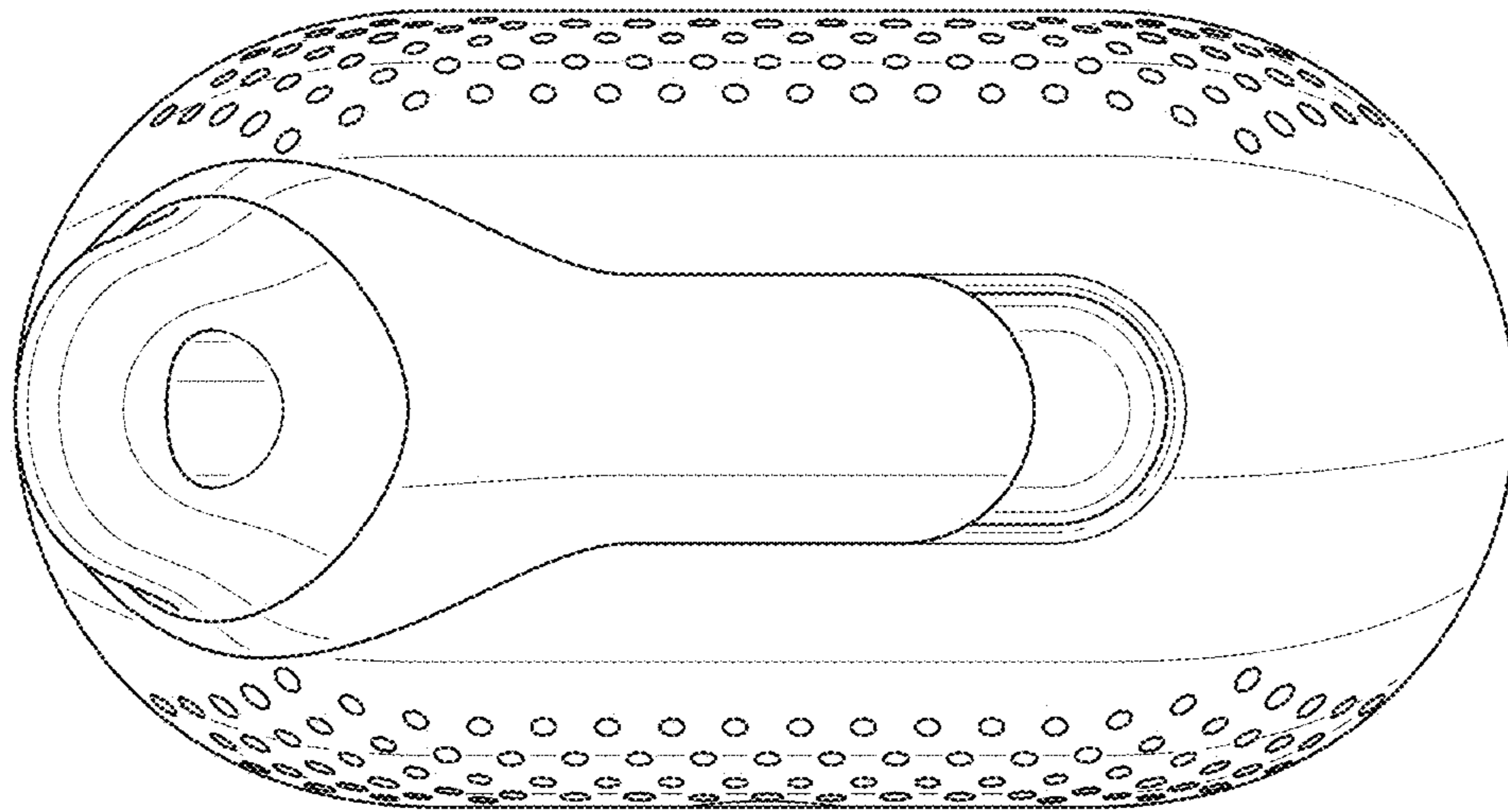

FIG. 72

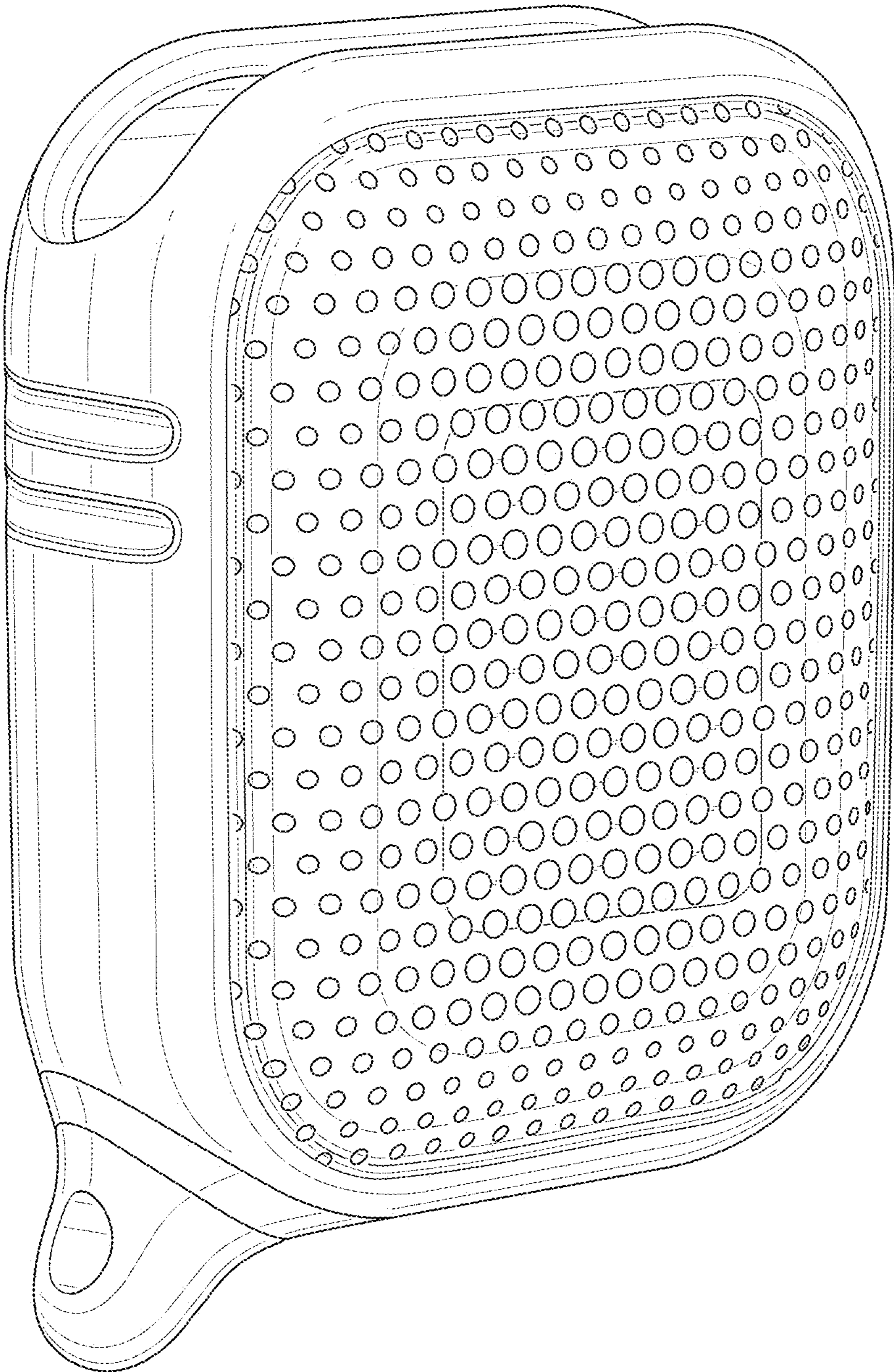

FIG. 73

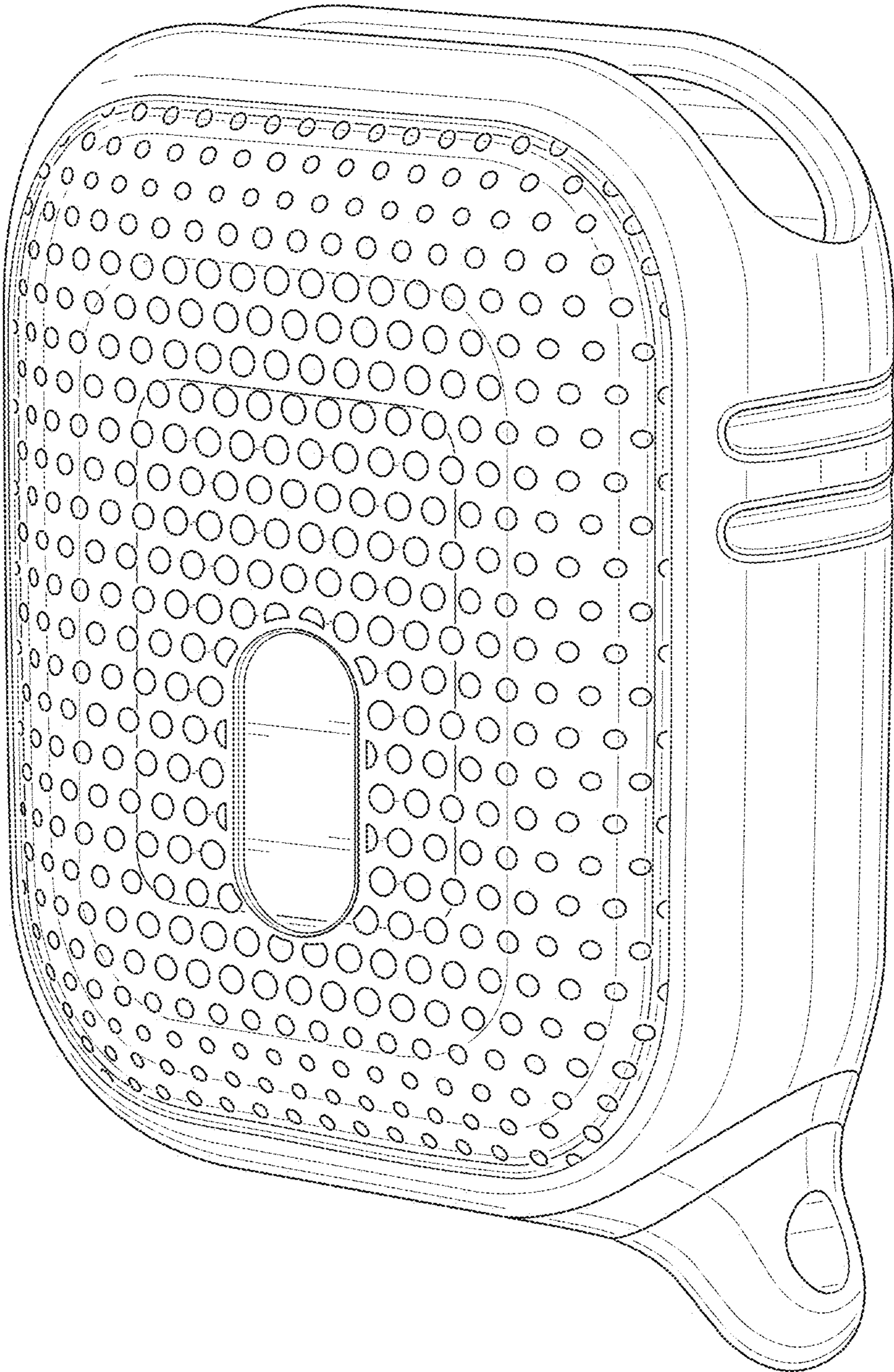

FIG. 74

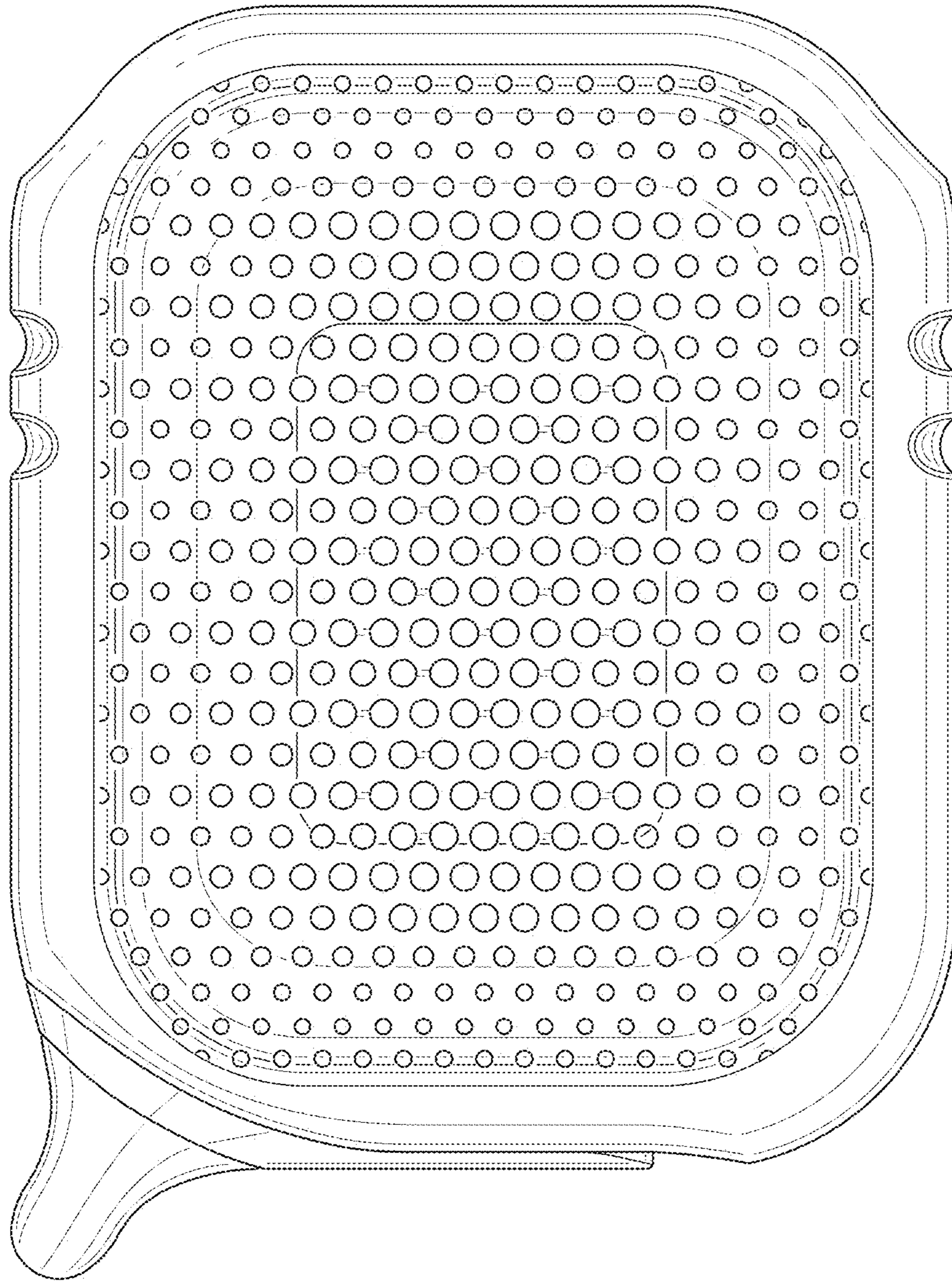

FIG. 75

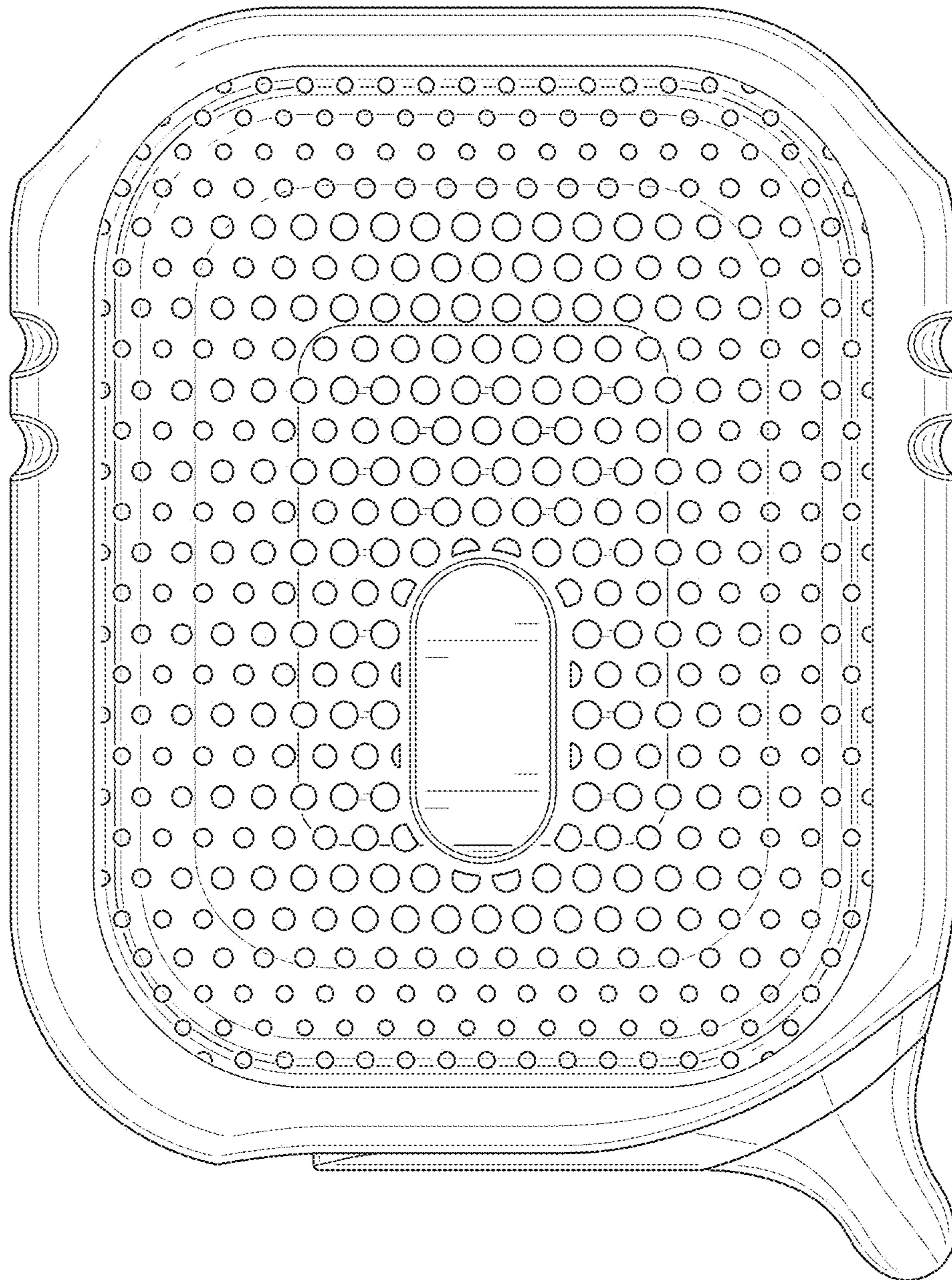

FIG. 76

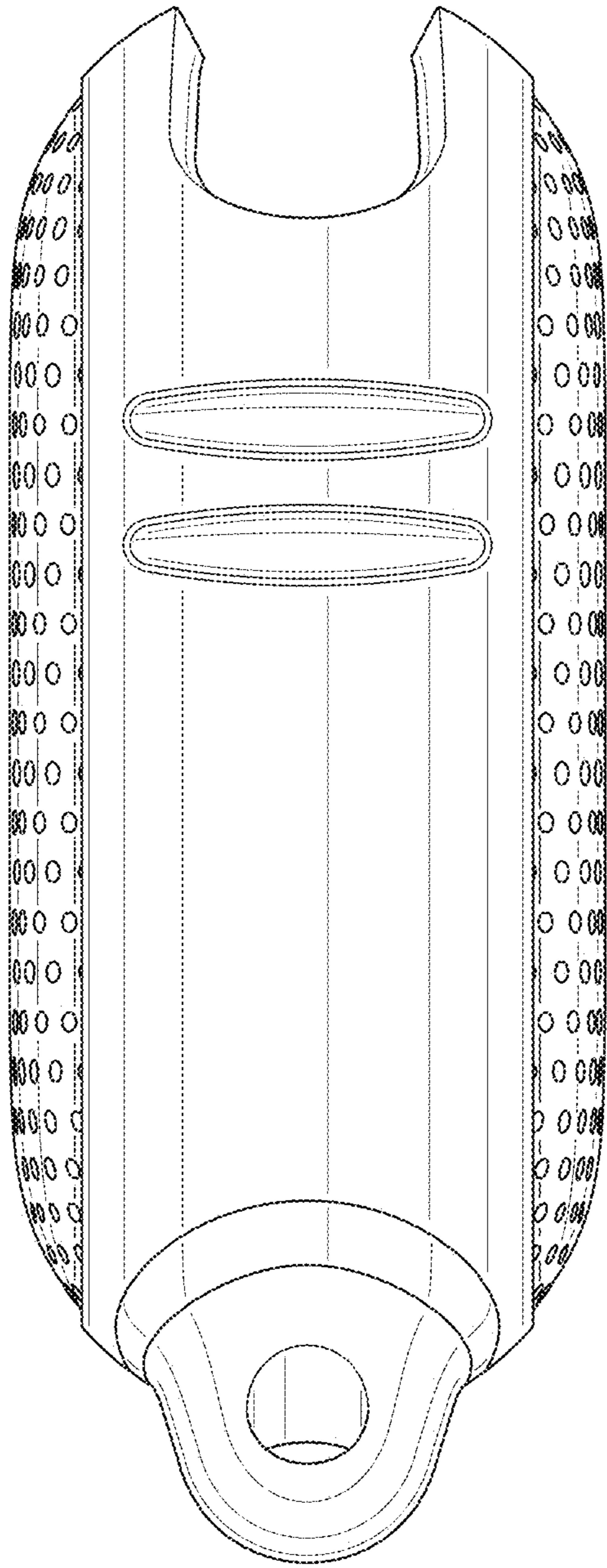

FIG. 77

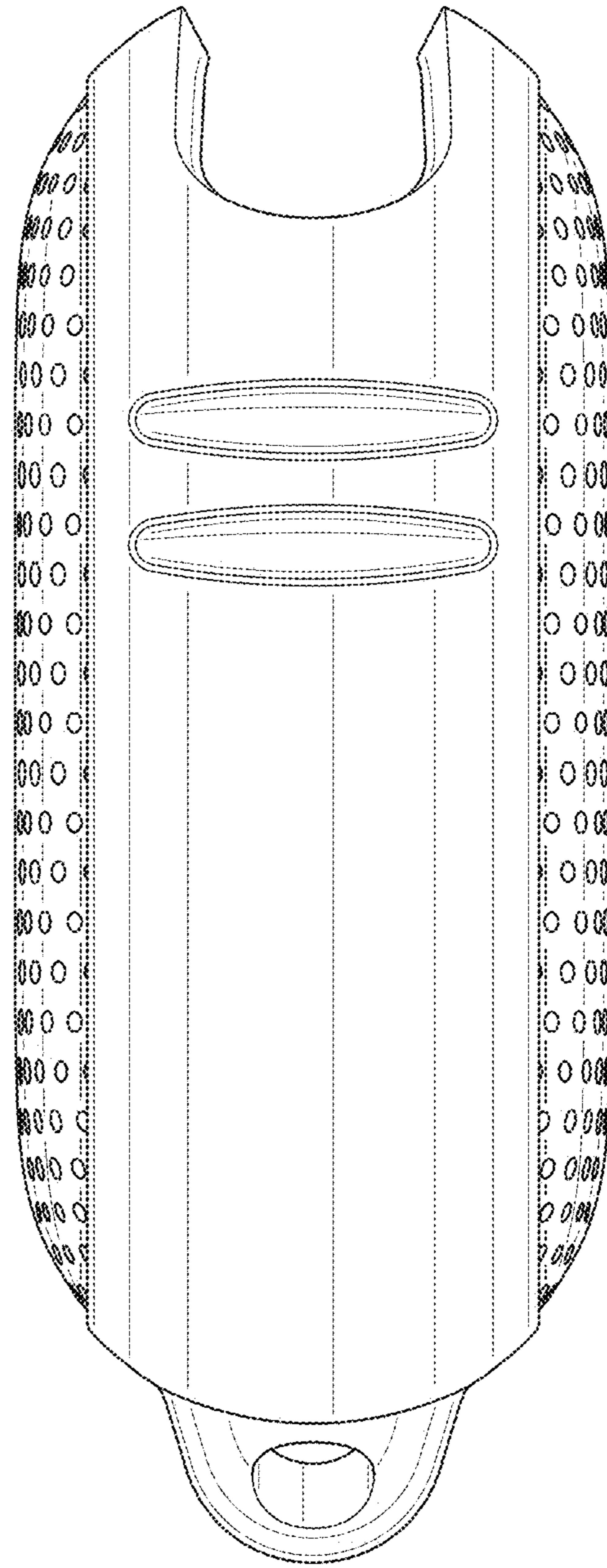

FIG. 78

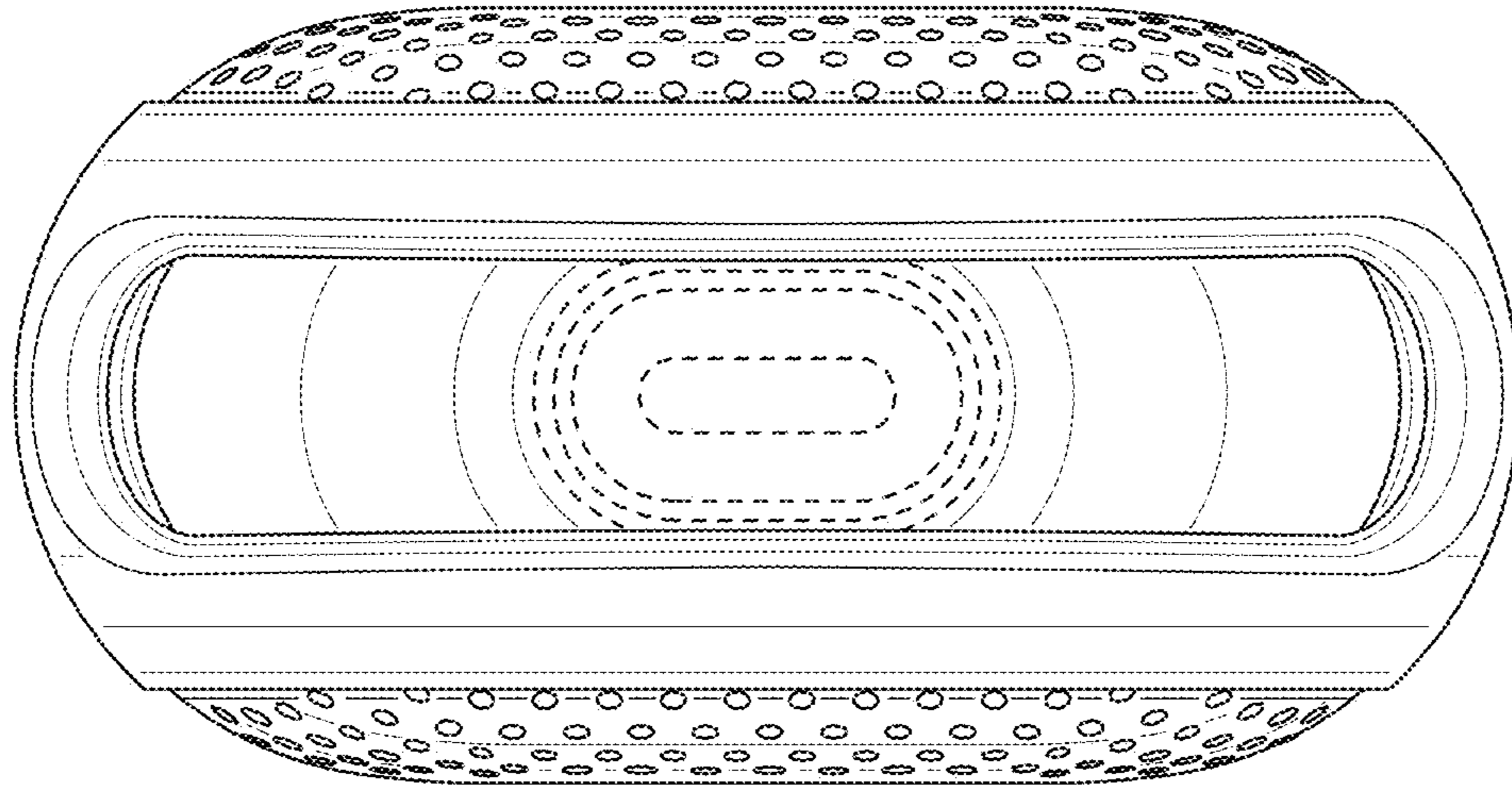

FIG. 79

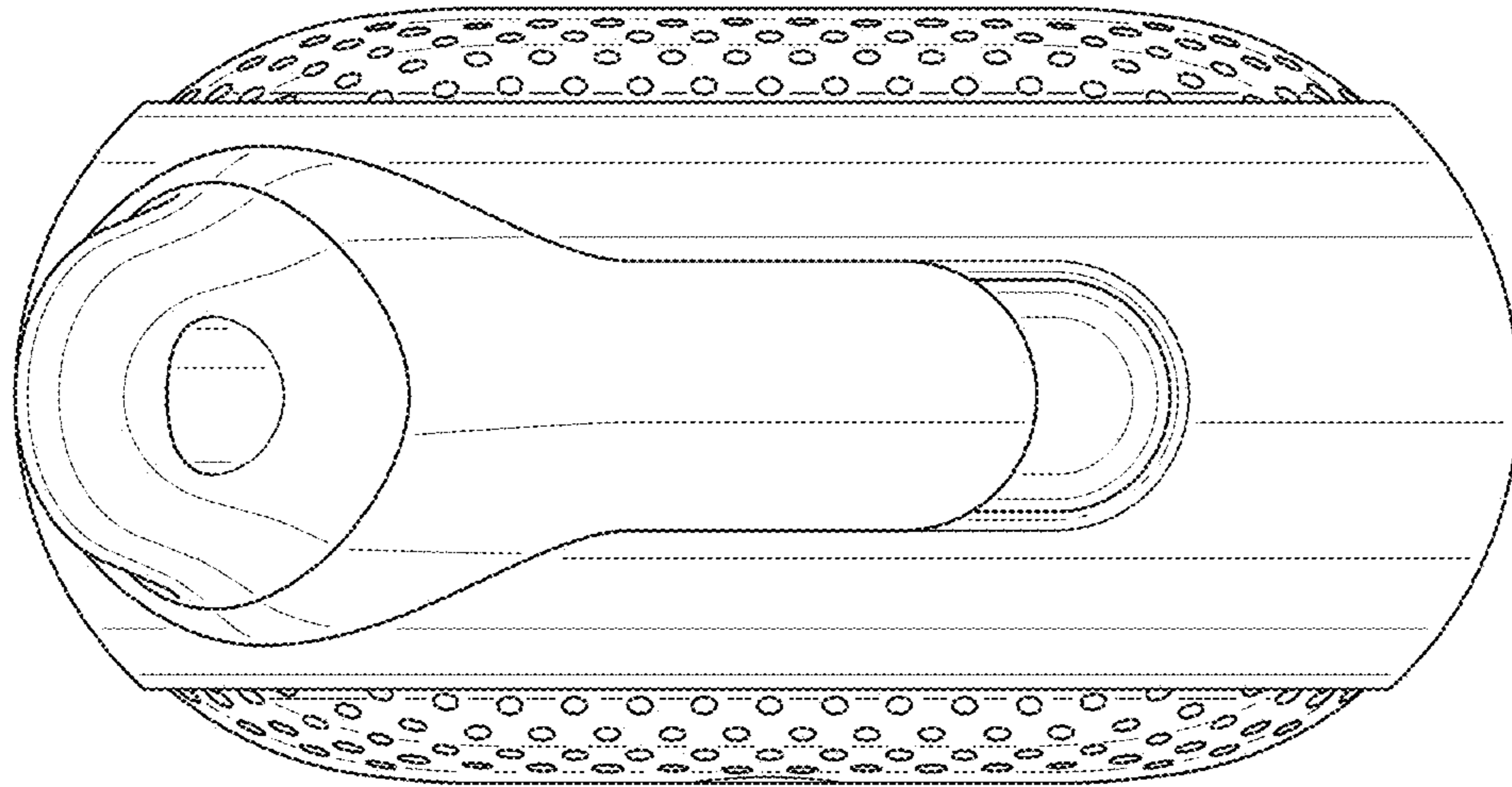

FIG. 80

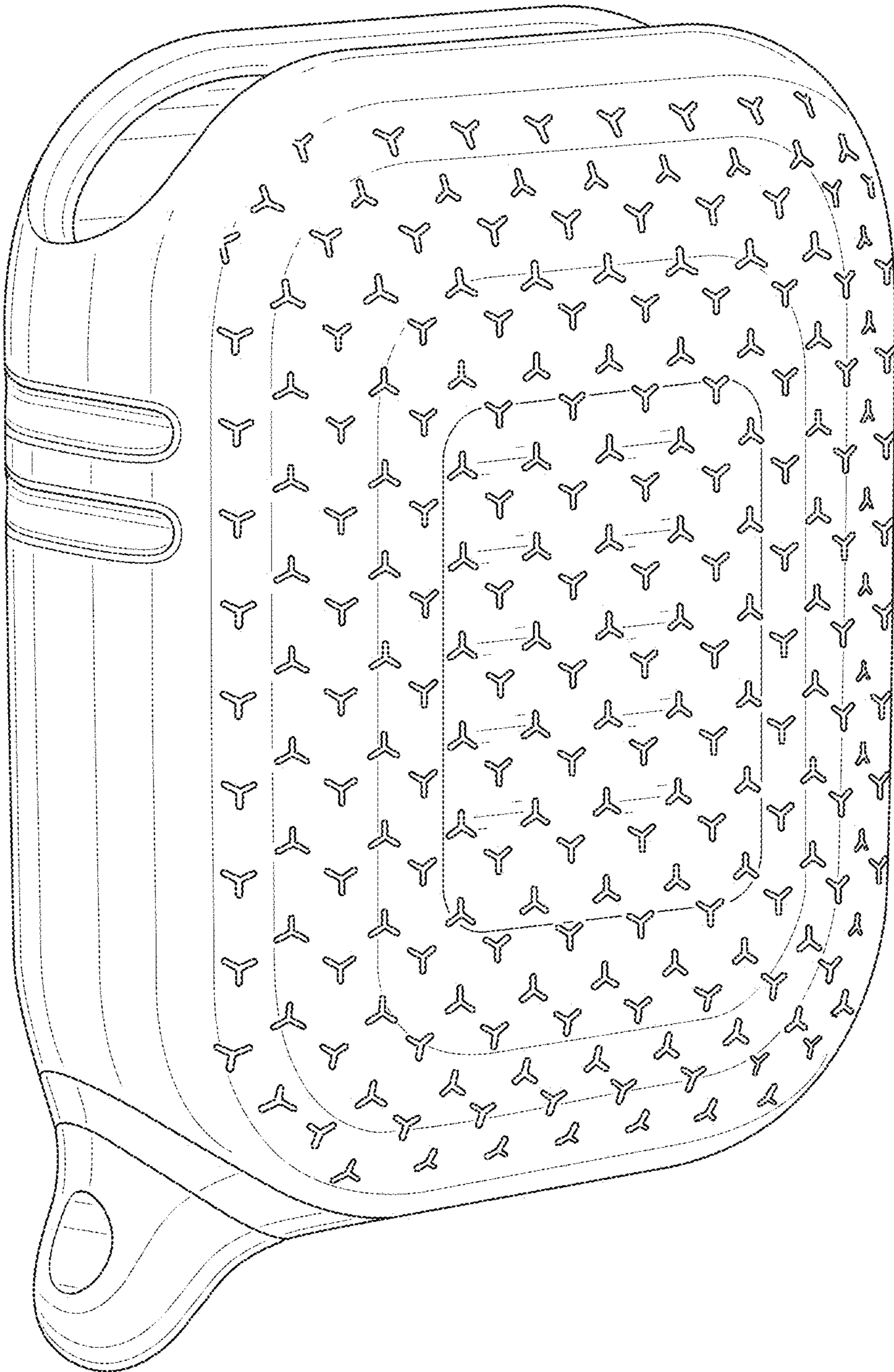

FIG. 81

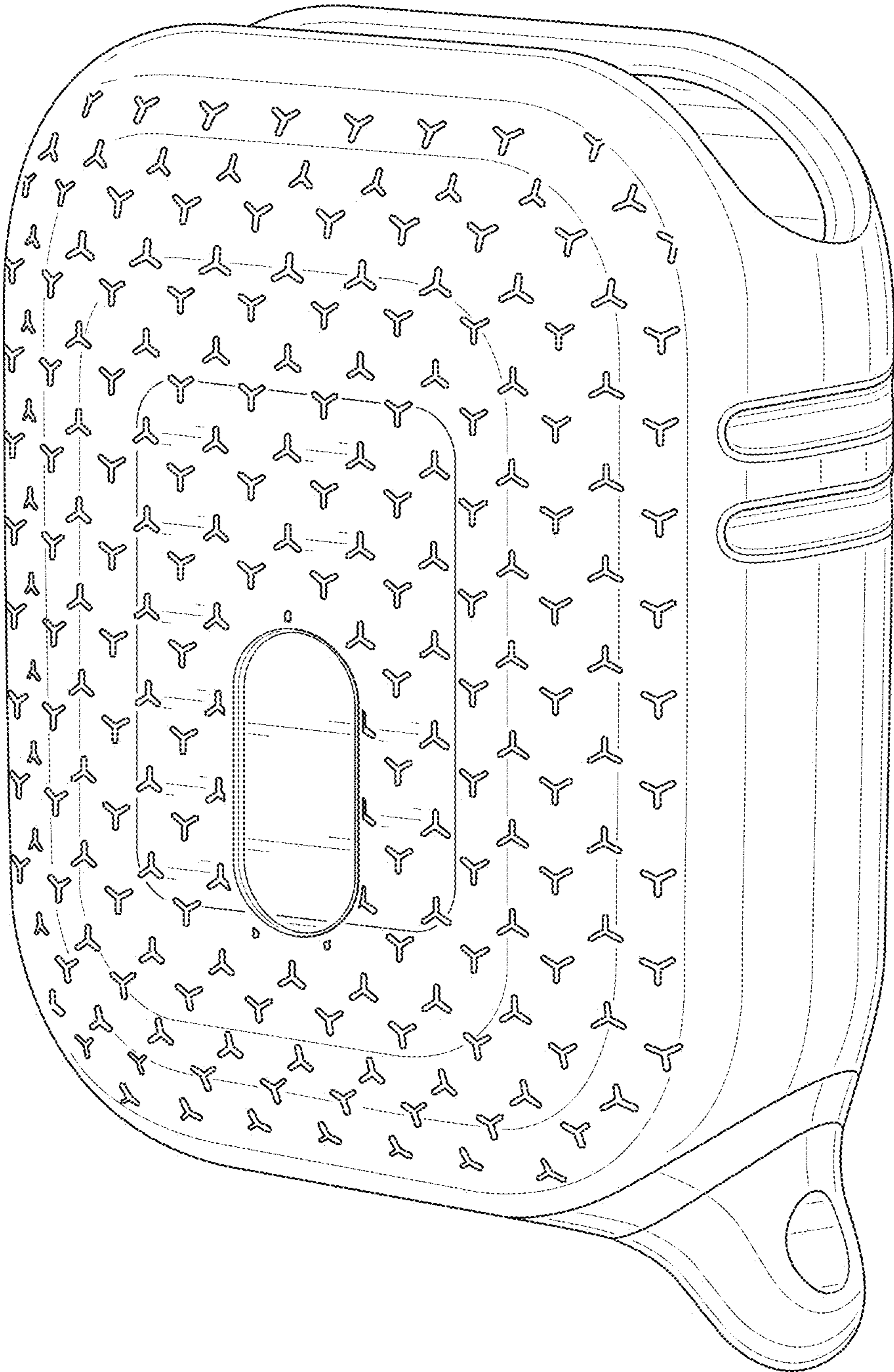

FIG. 82

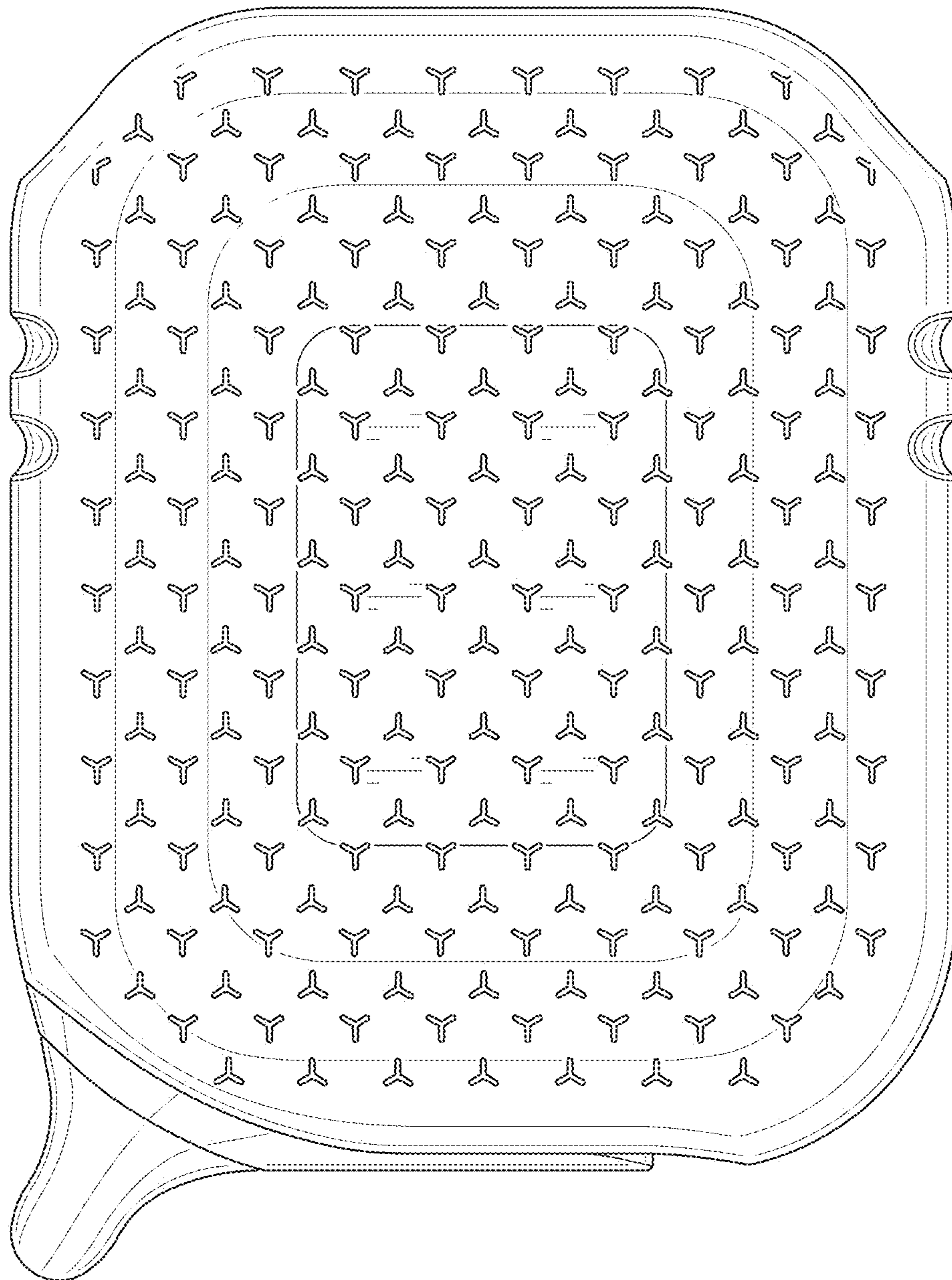

FIG. 83

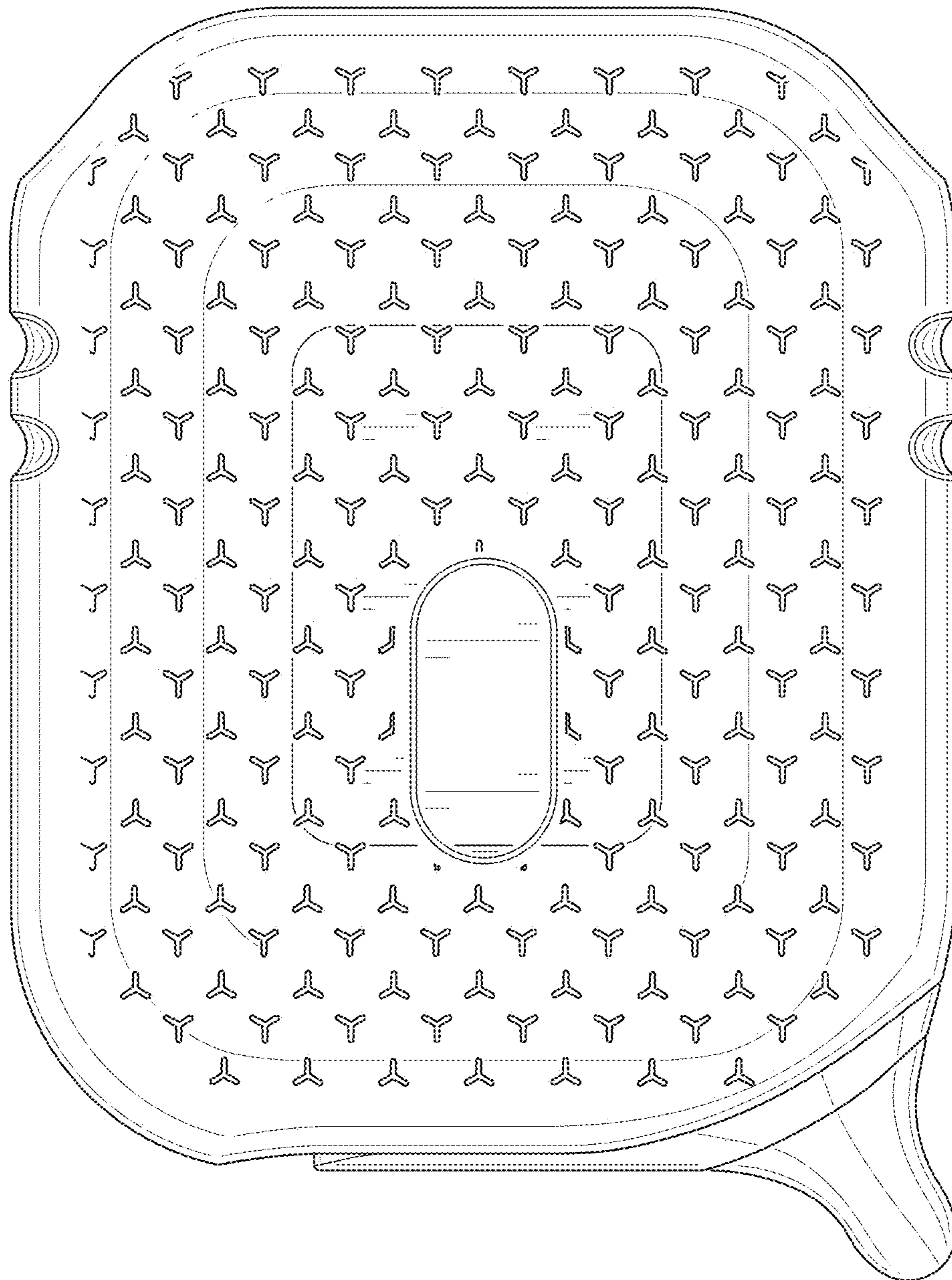

FIG. 84

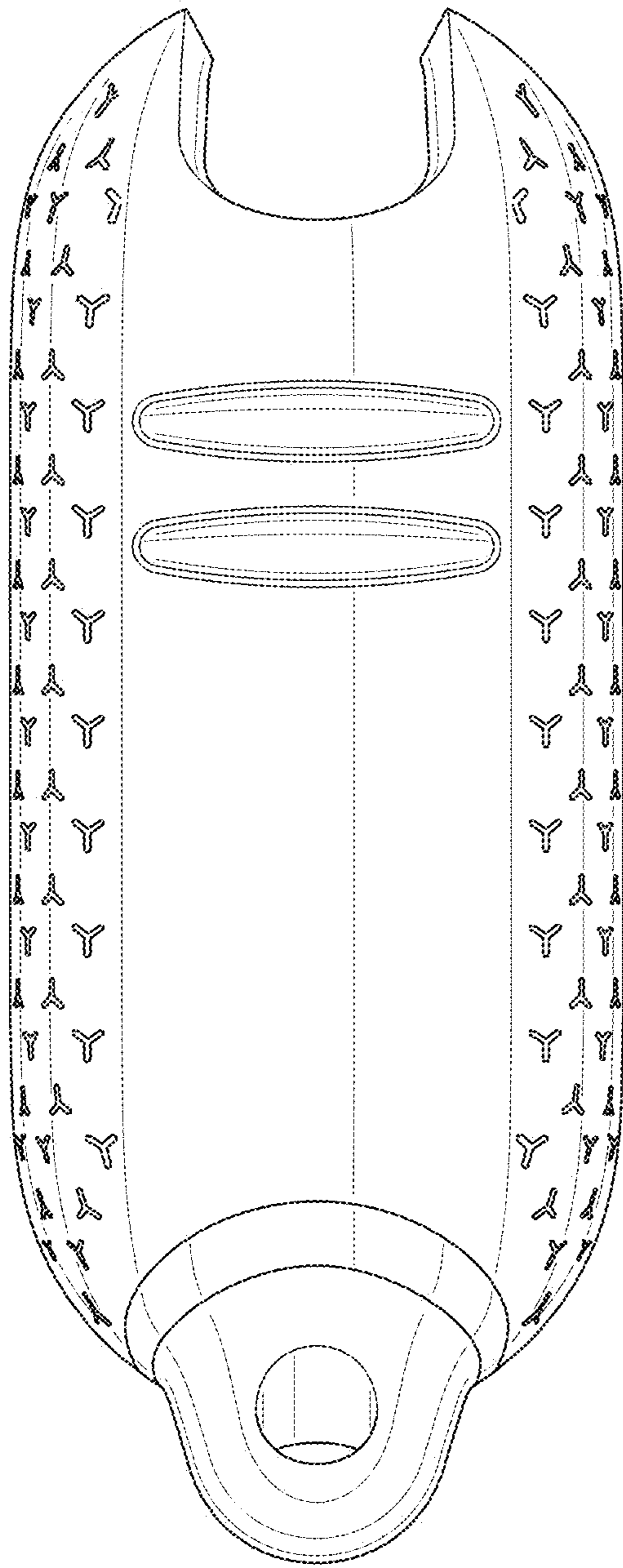

FIG. 85

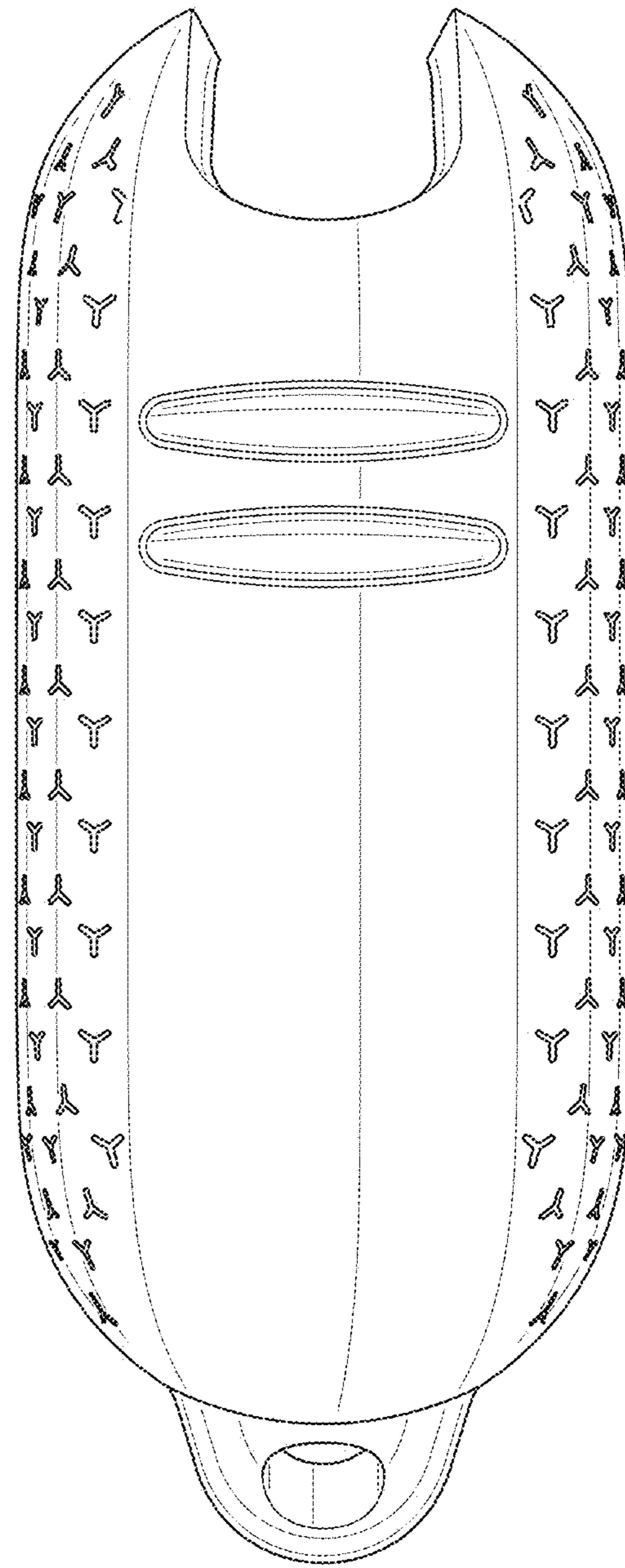

FIG. 86

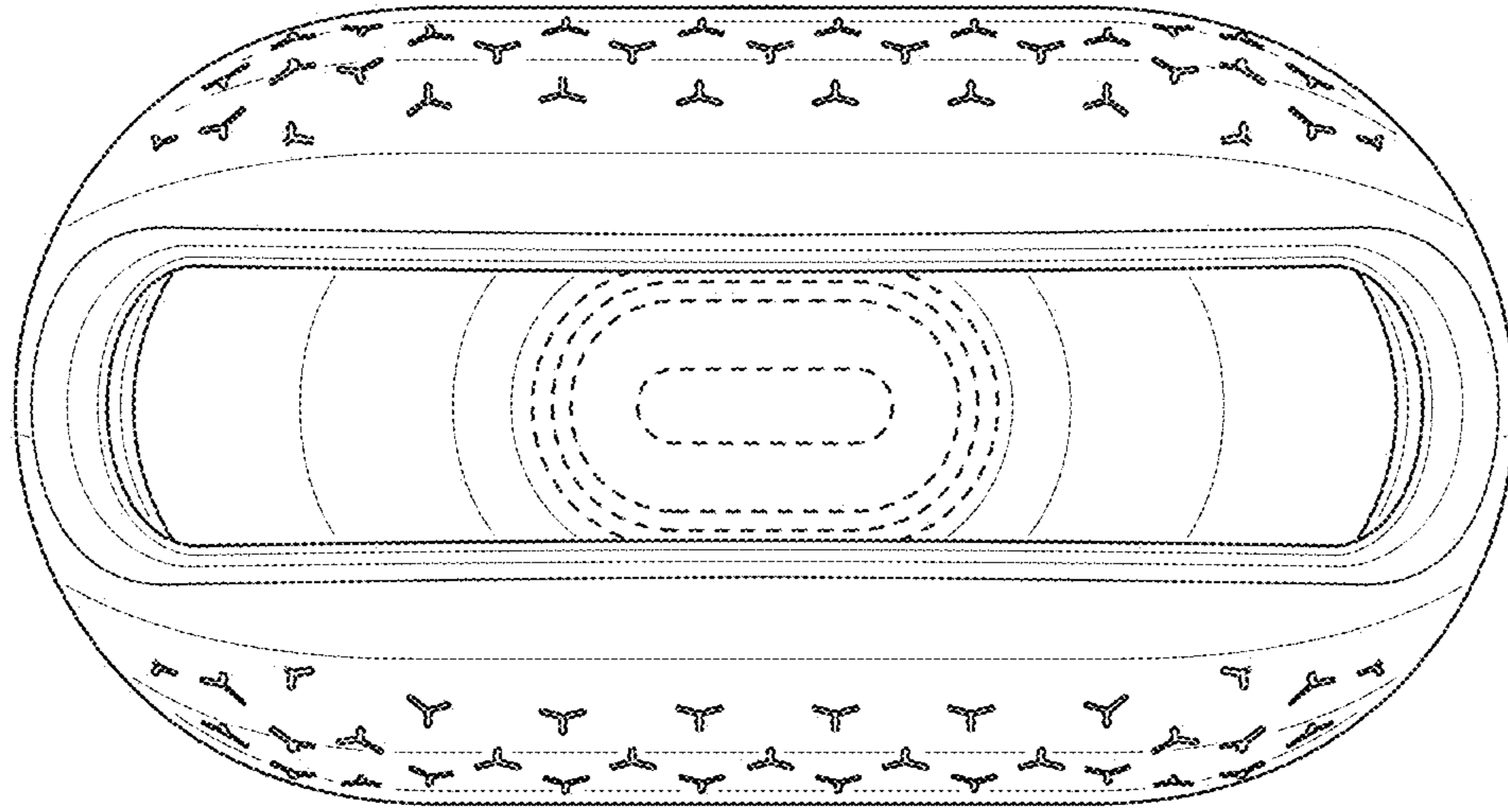

FIG. 87

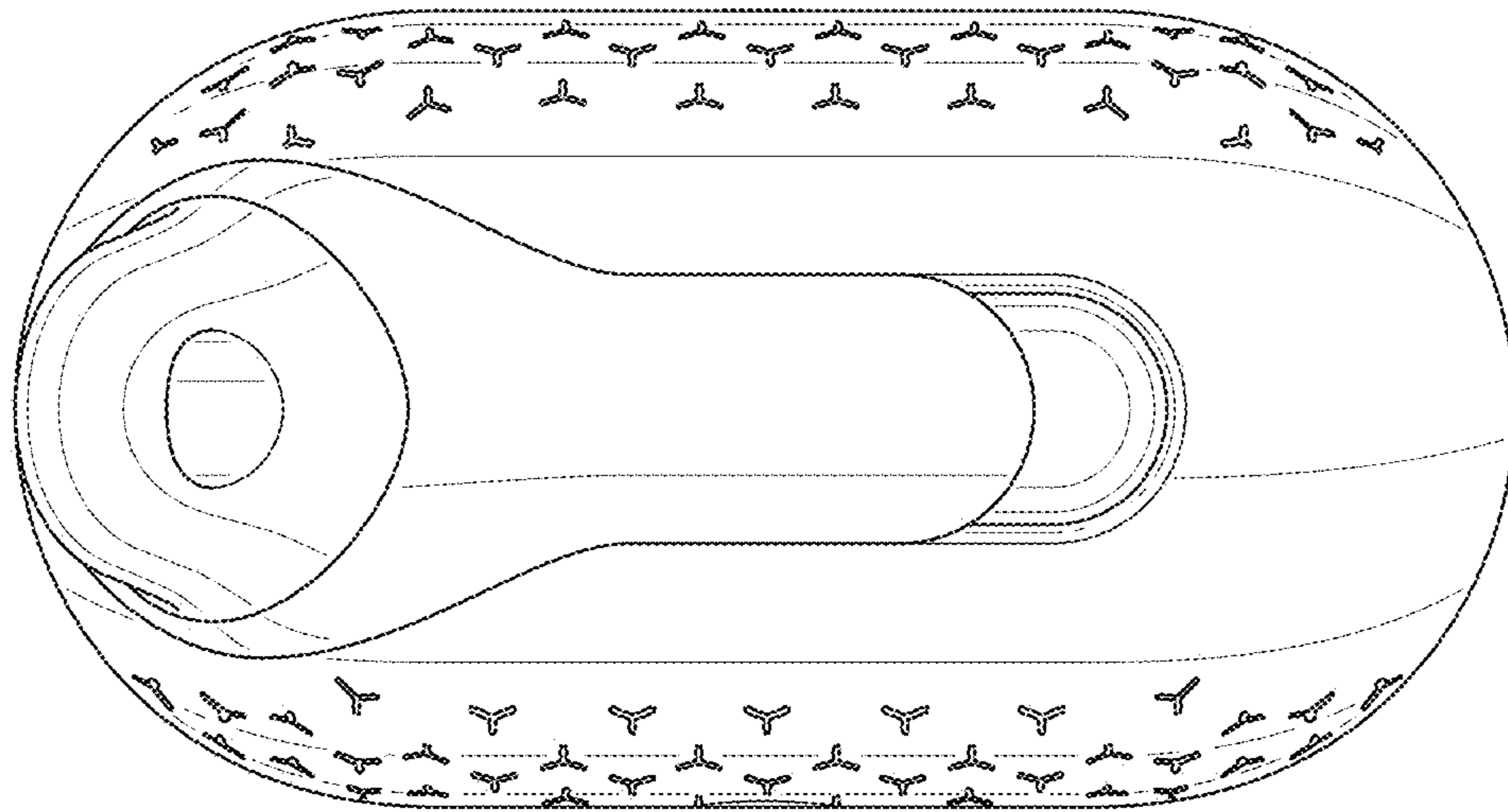

FIG. 88



FIG. 89

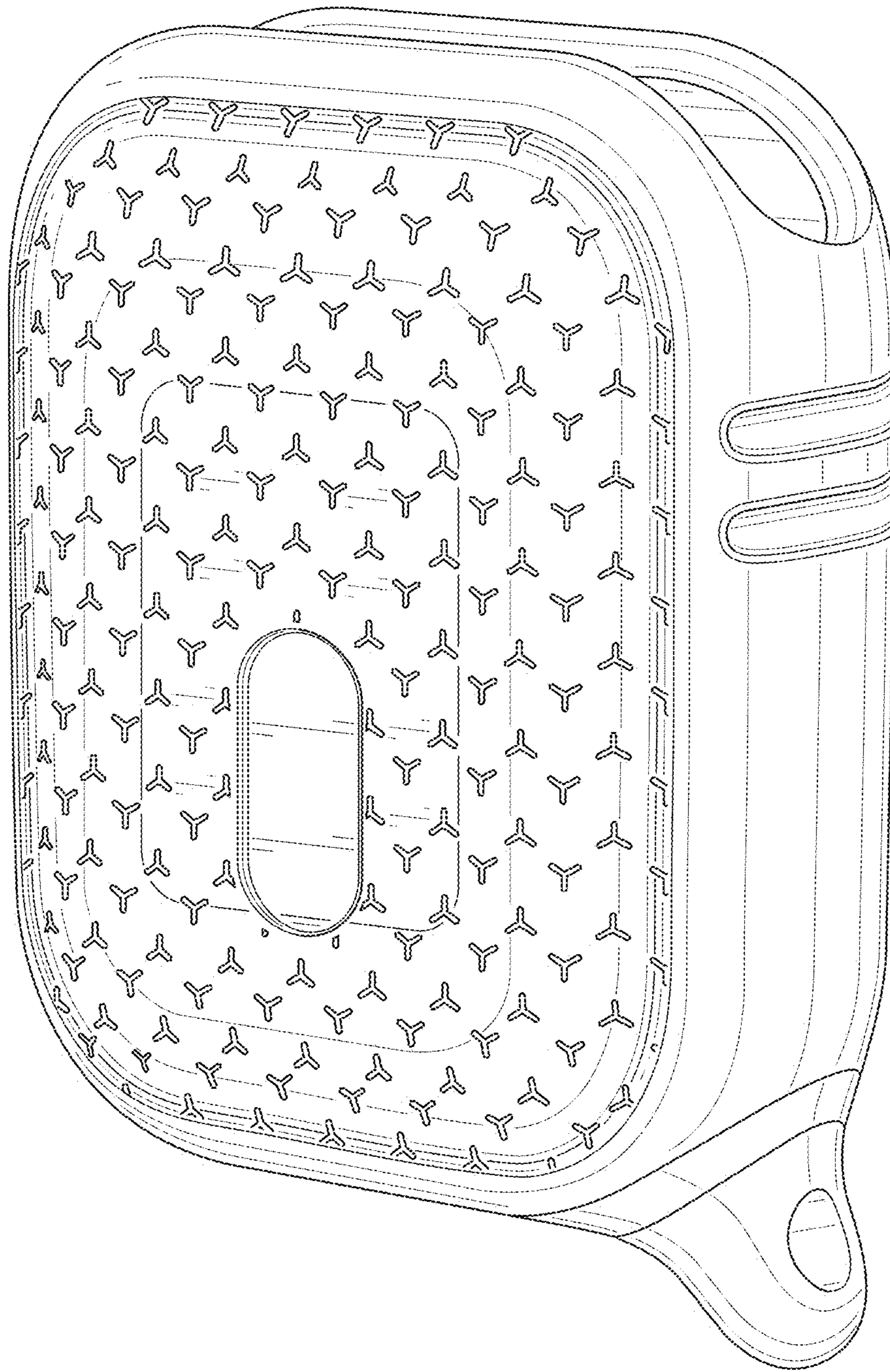

FIG. 90

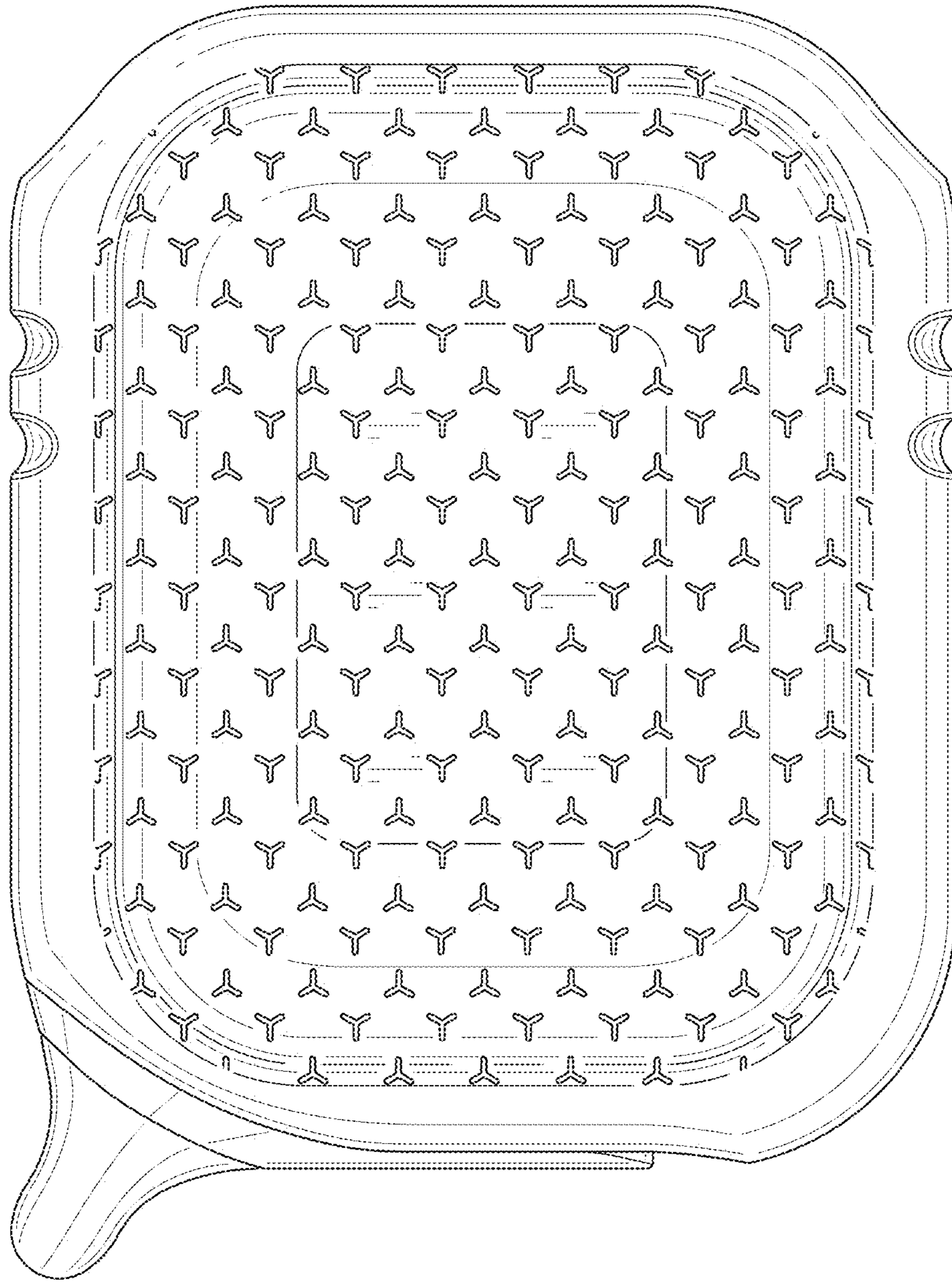

FIG. 91

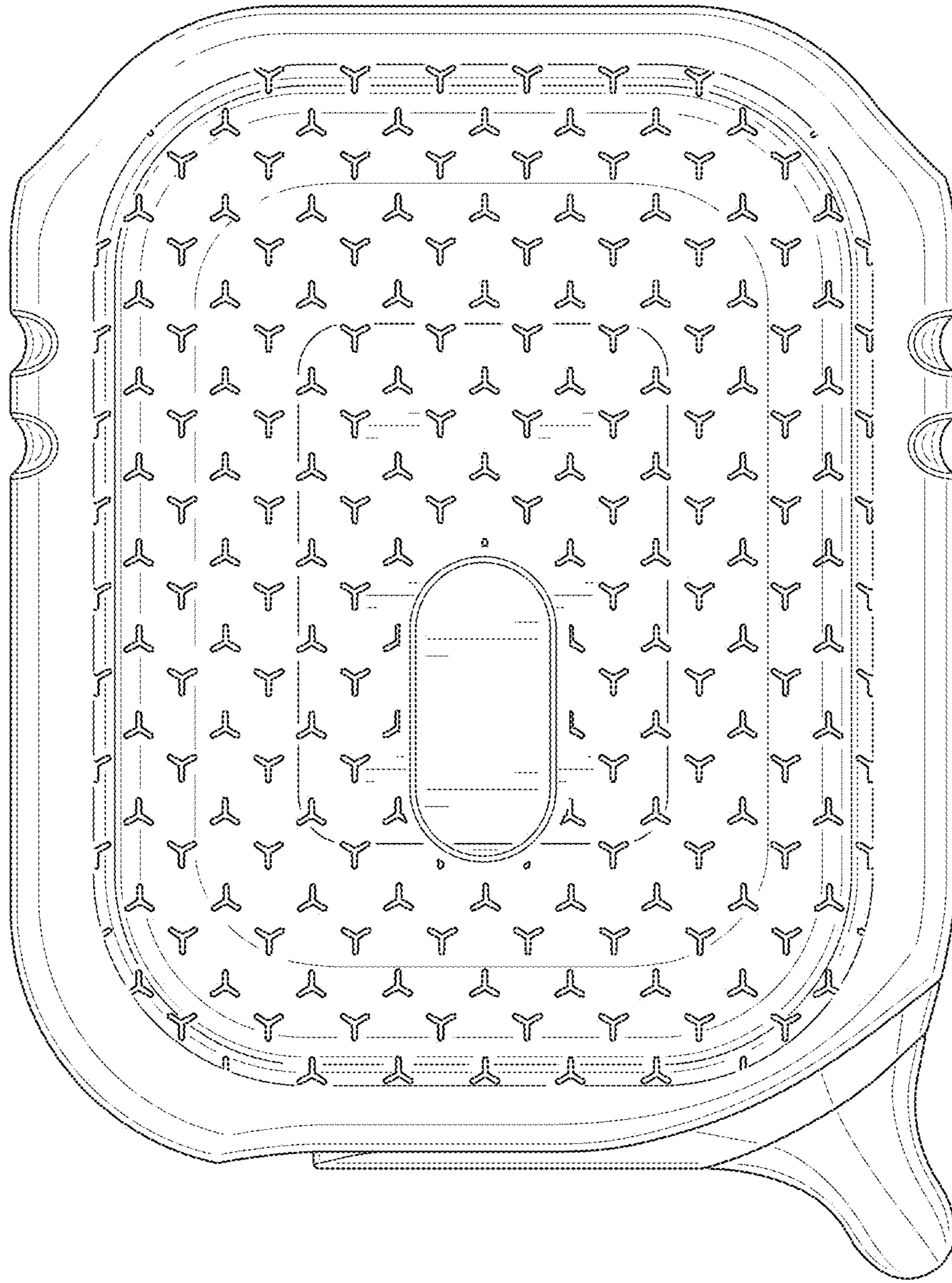

FIG. 92

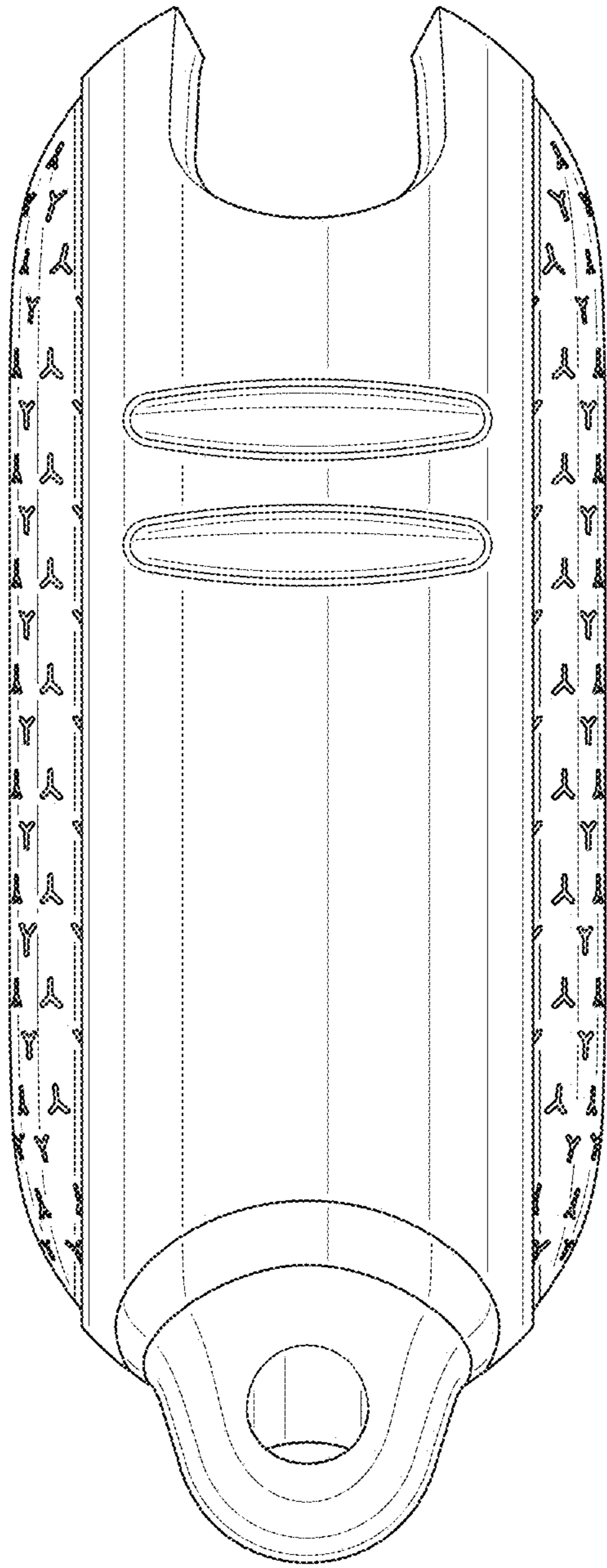

FIG. 93

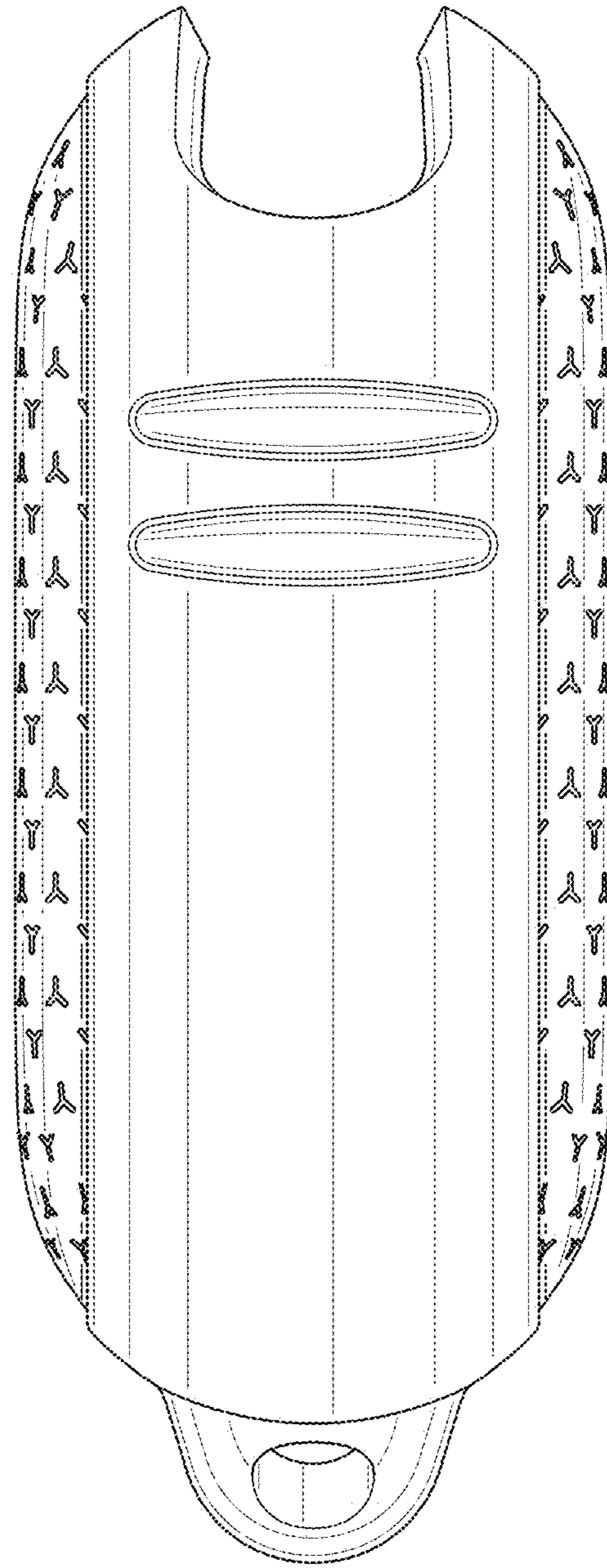

FIG. 94

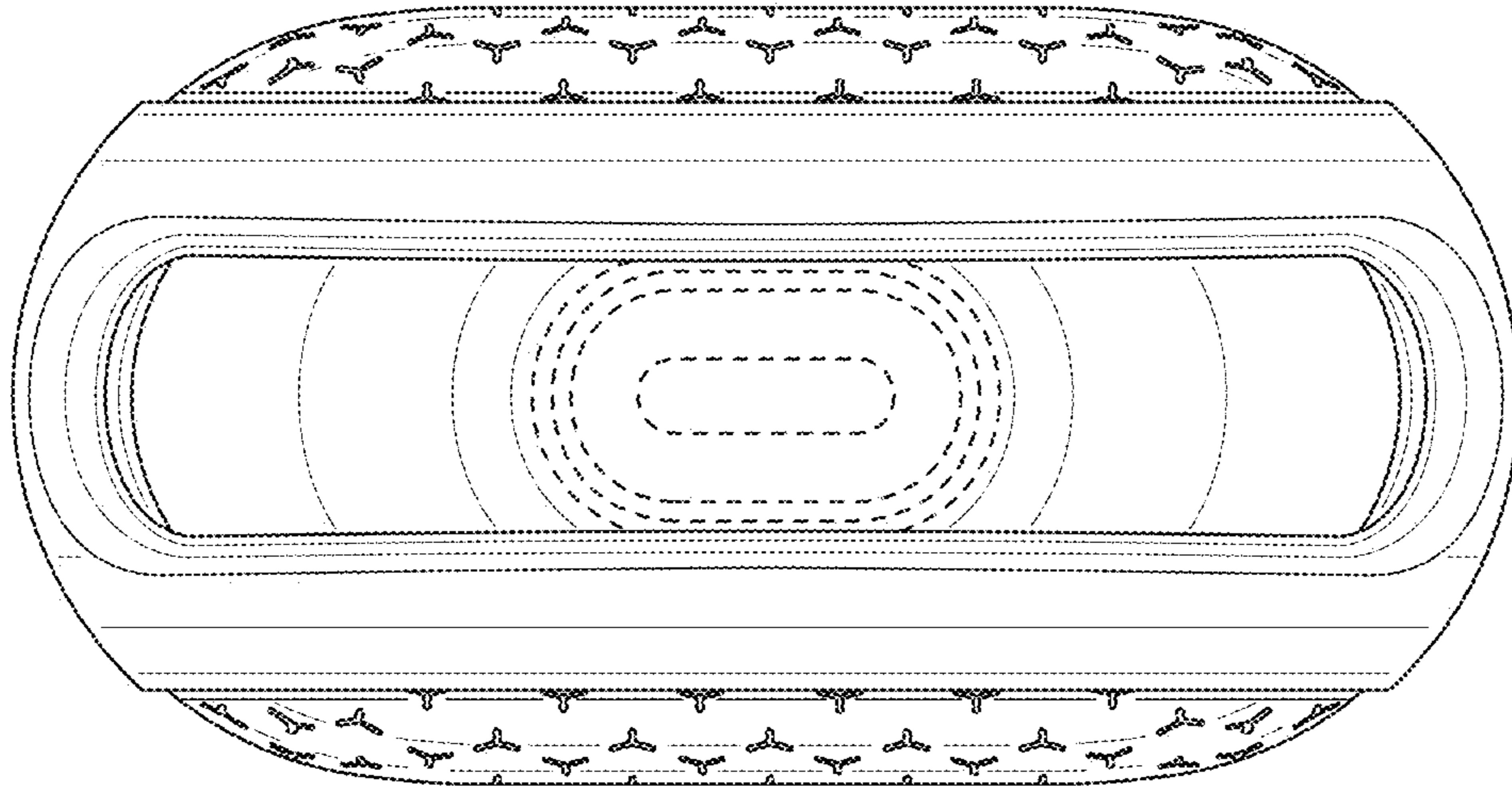

FIG. 95

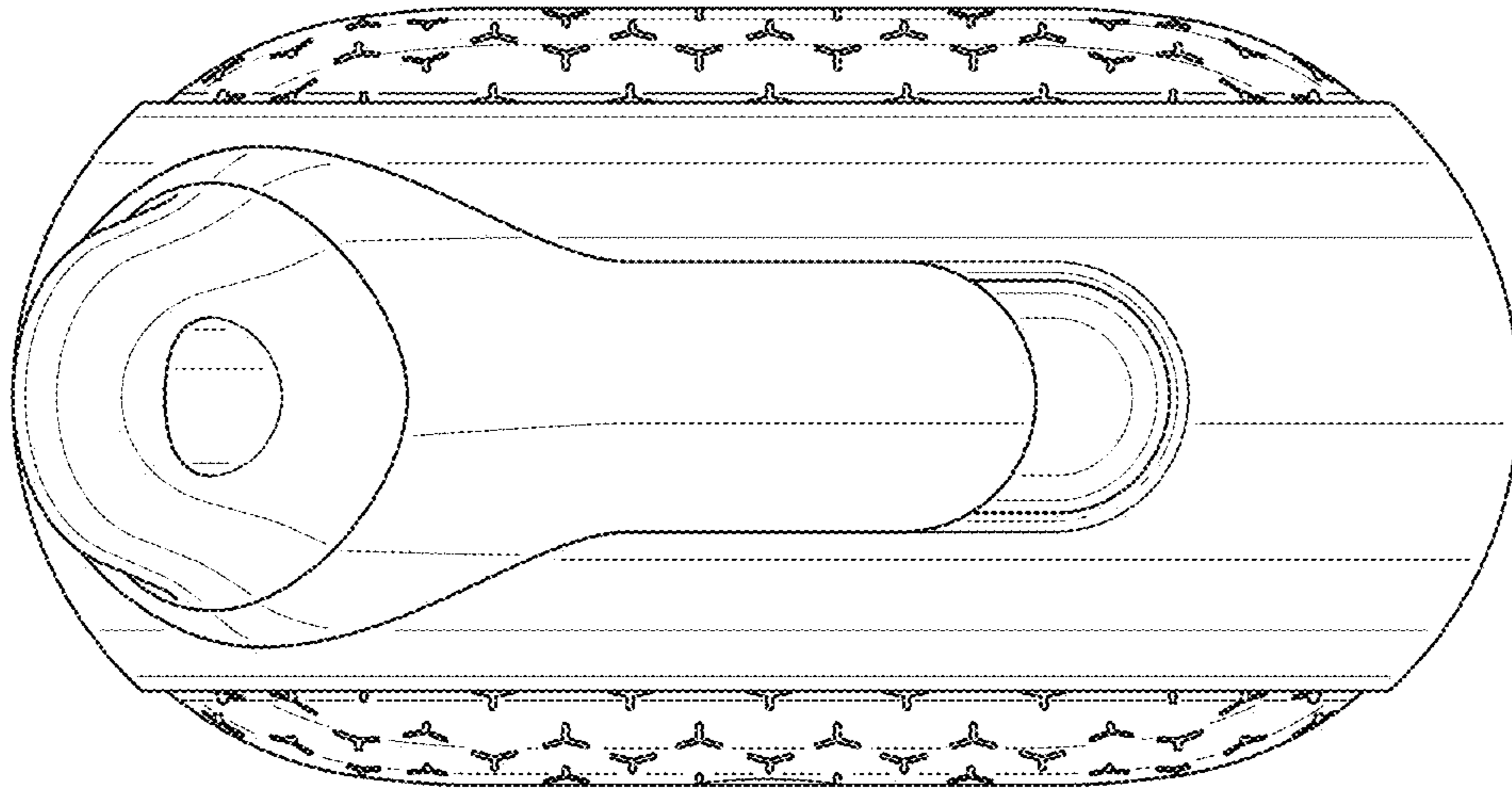

FIG. 96

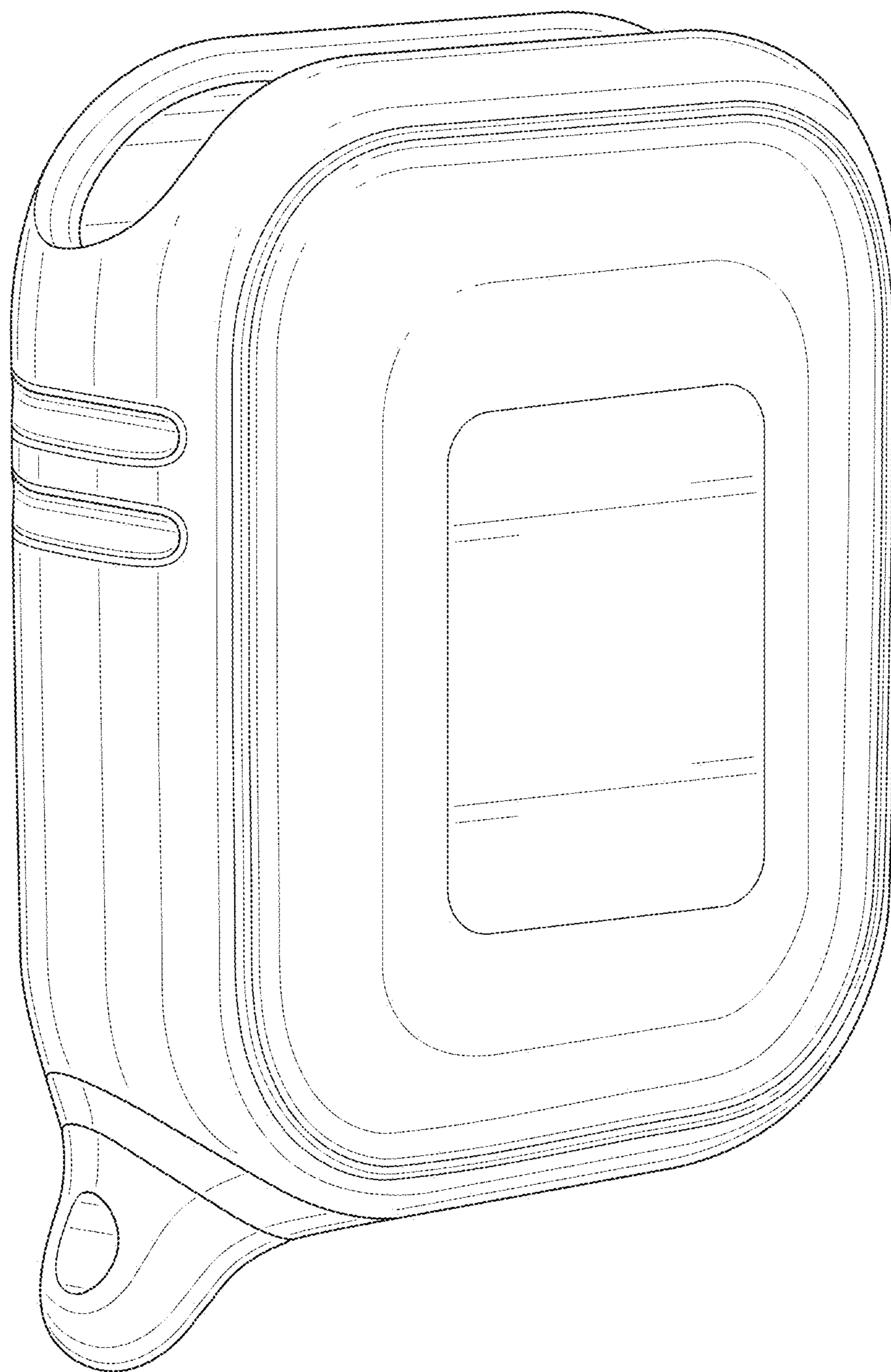

FIG. 97

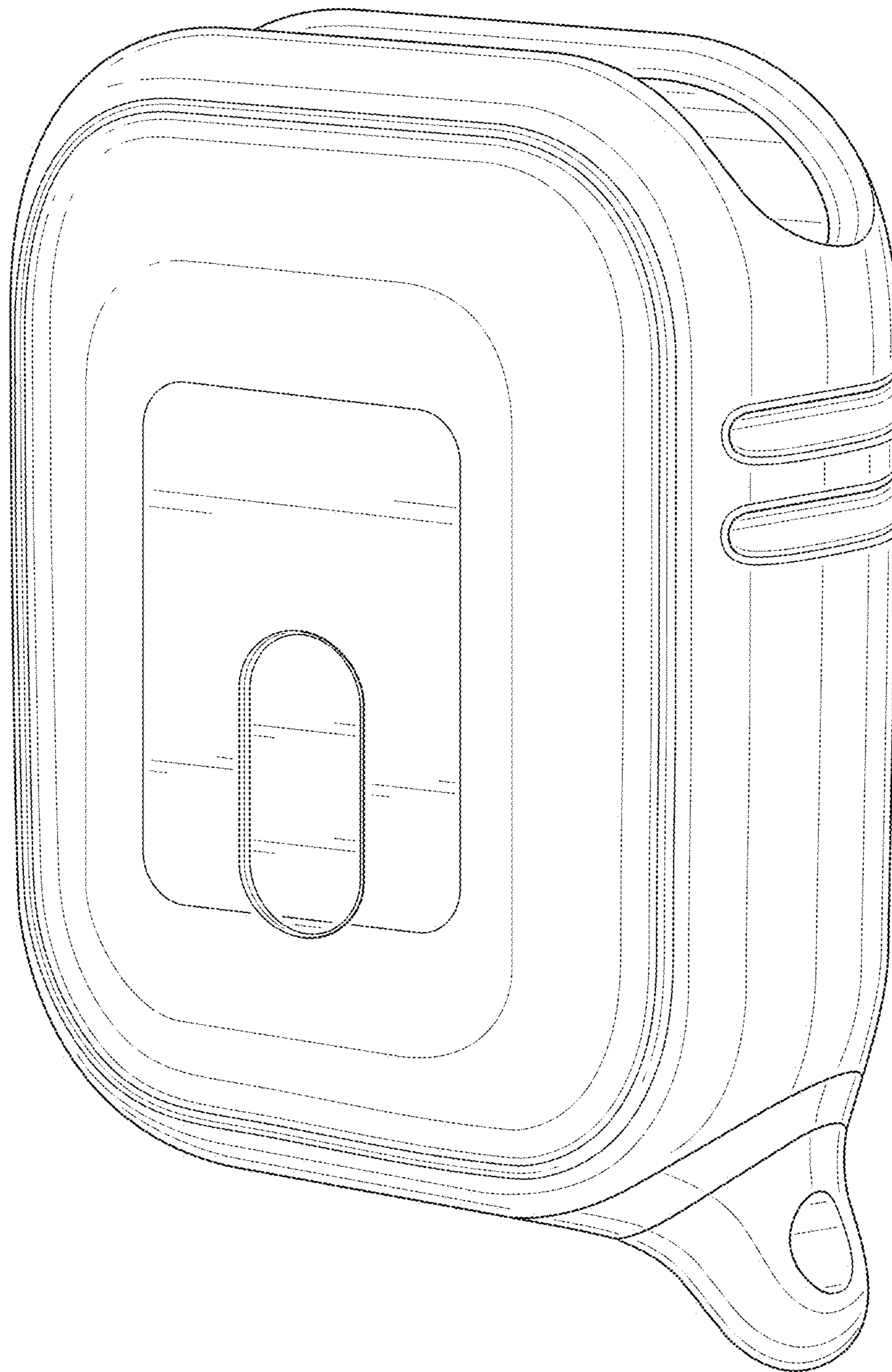

FIG. 98

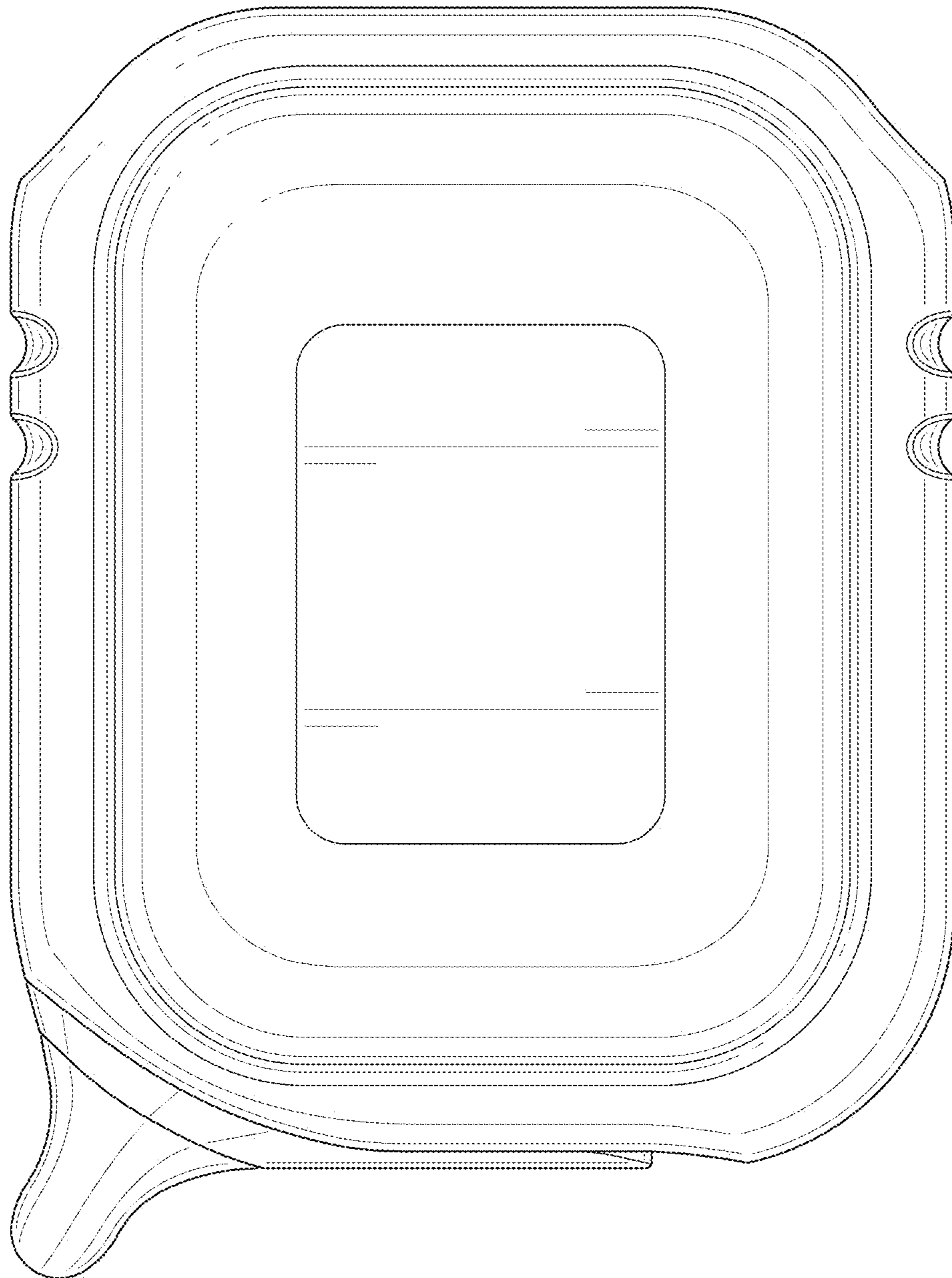

FIG. 99

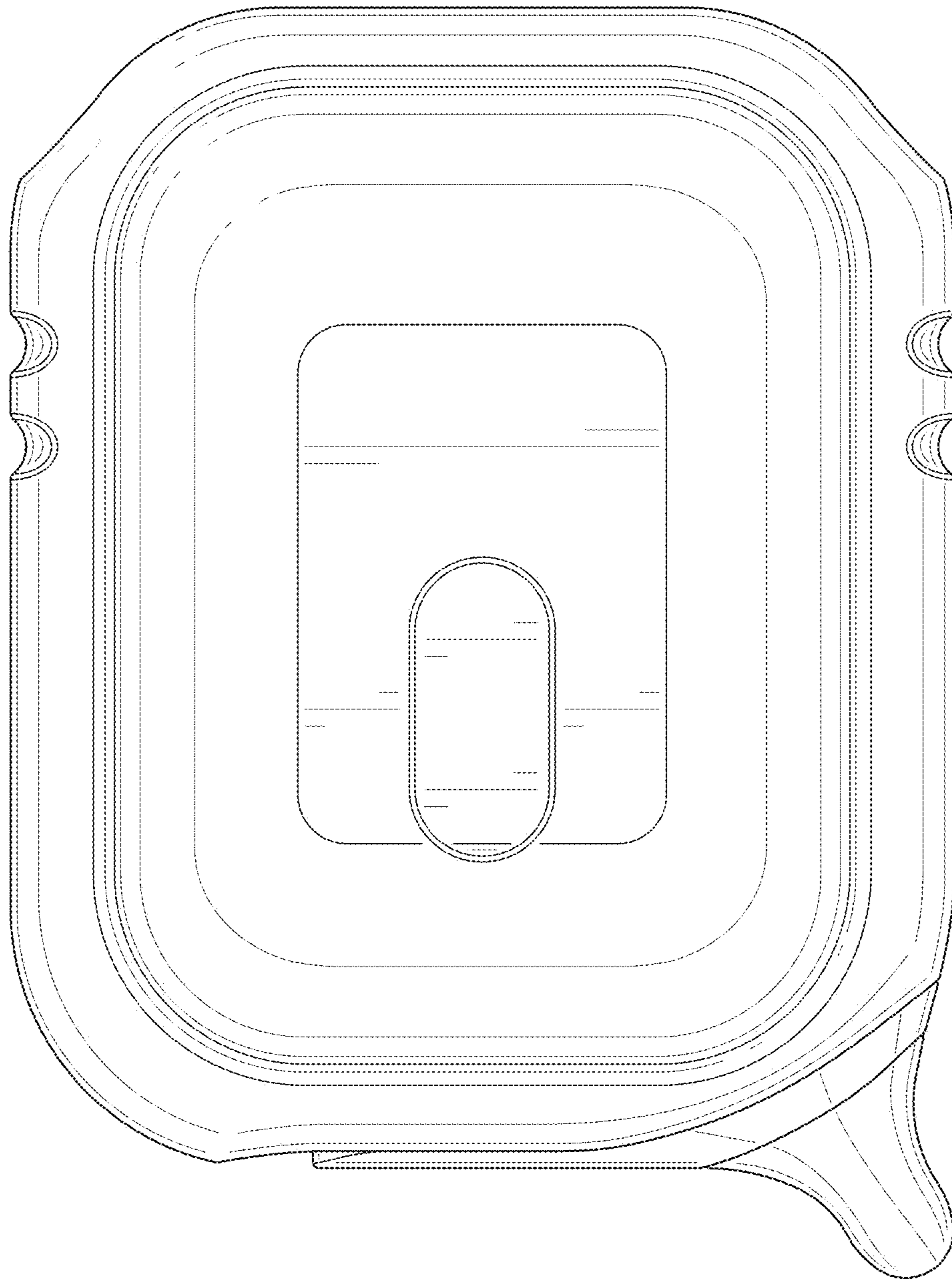

FIG. 100

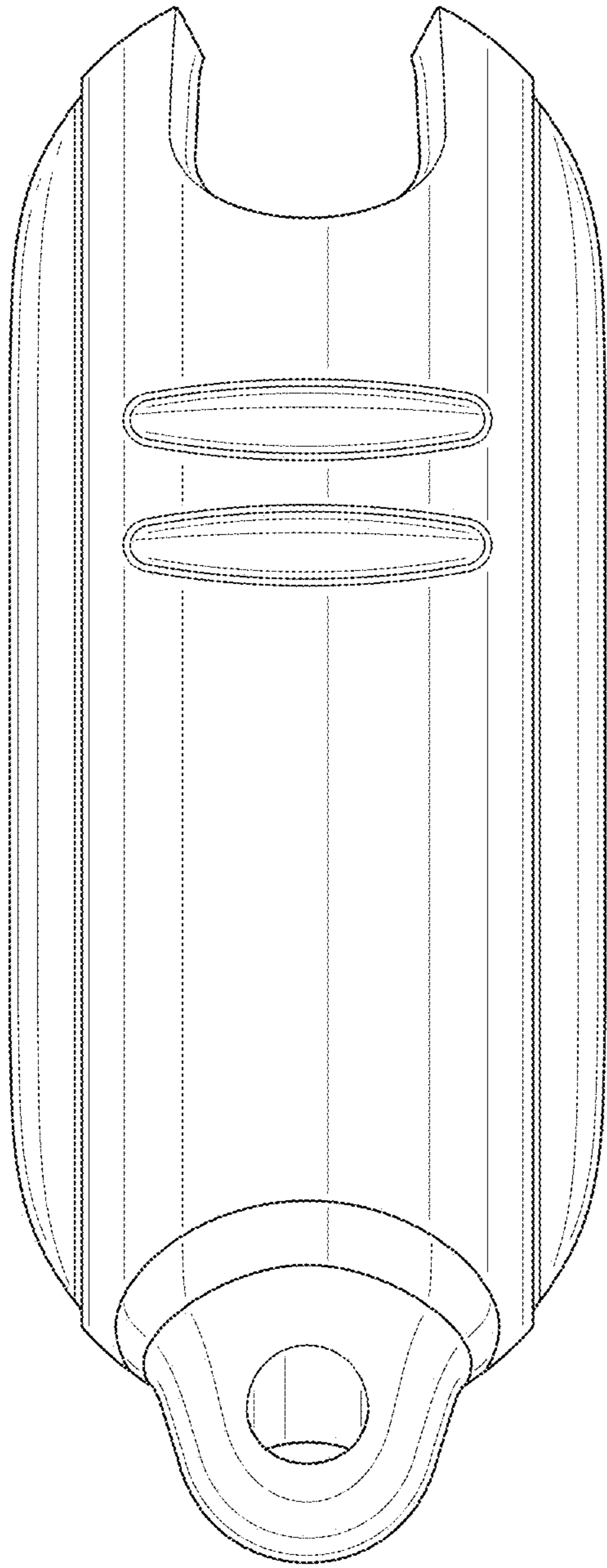

FIG. 101

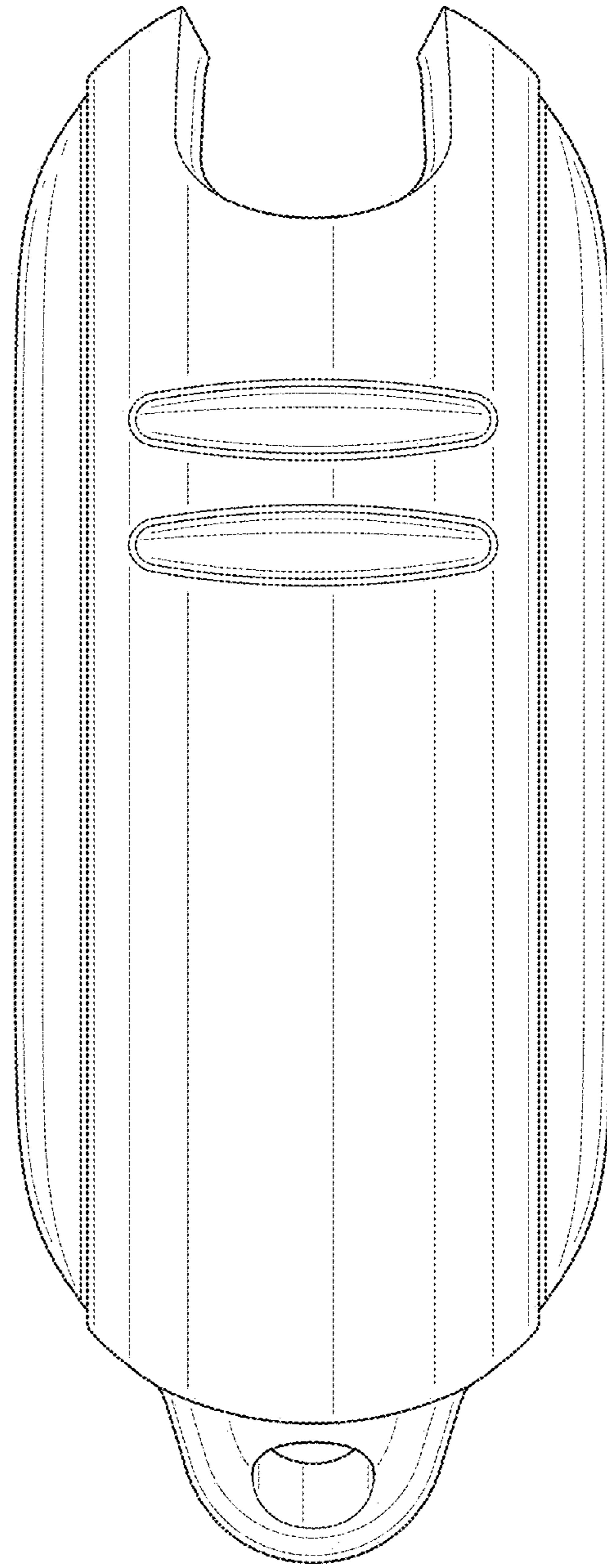

FIG. 102

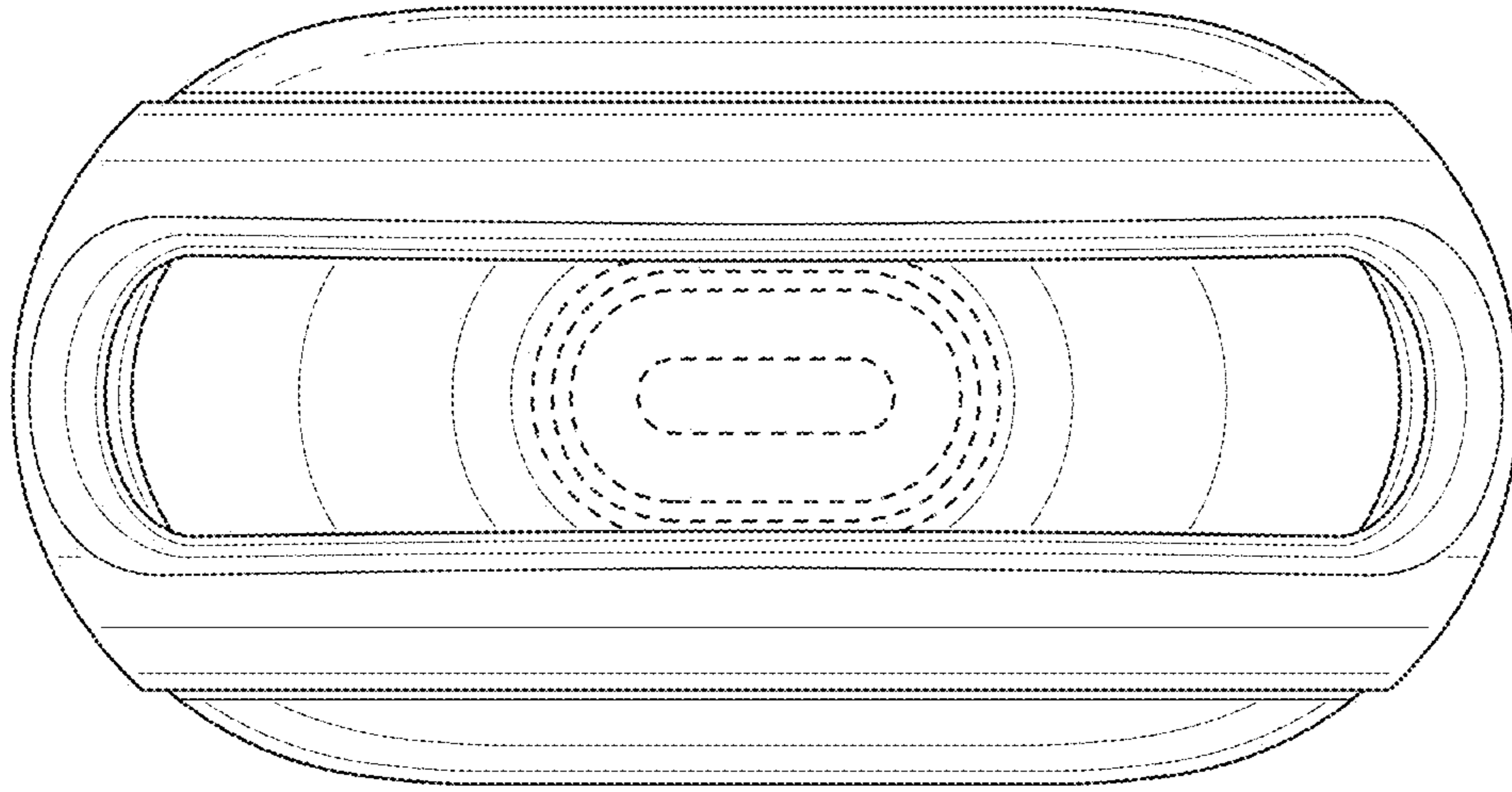

FIG. 103

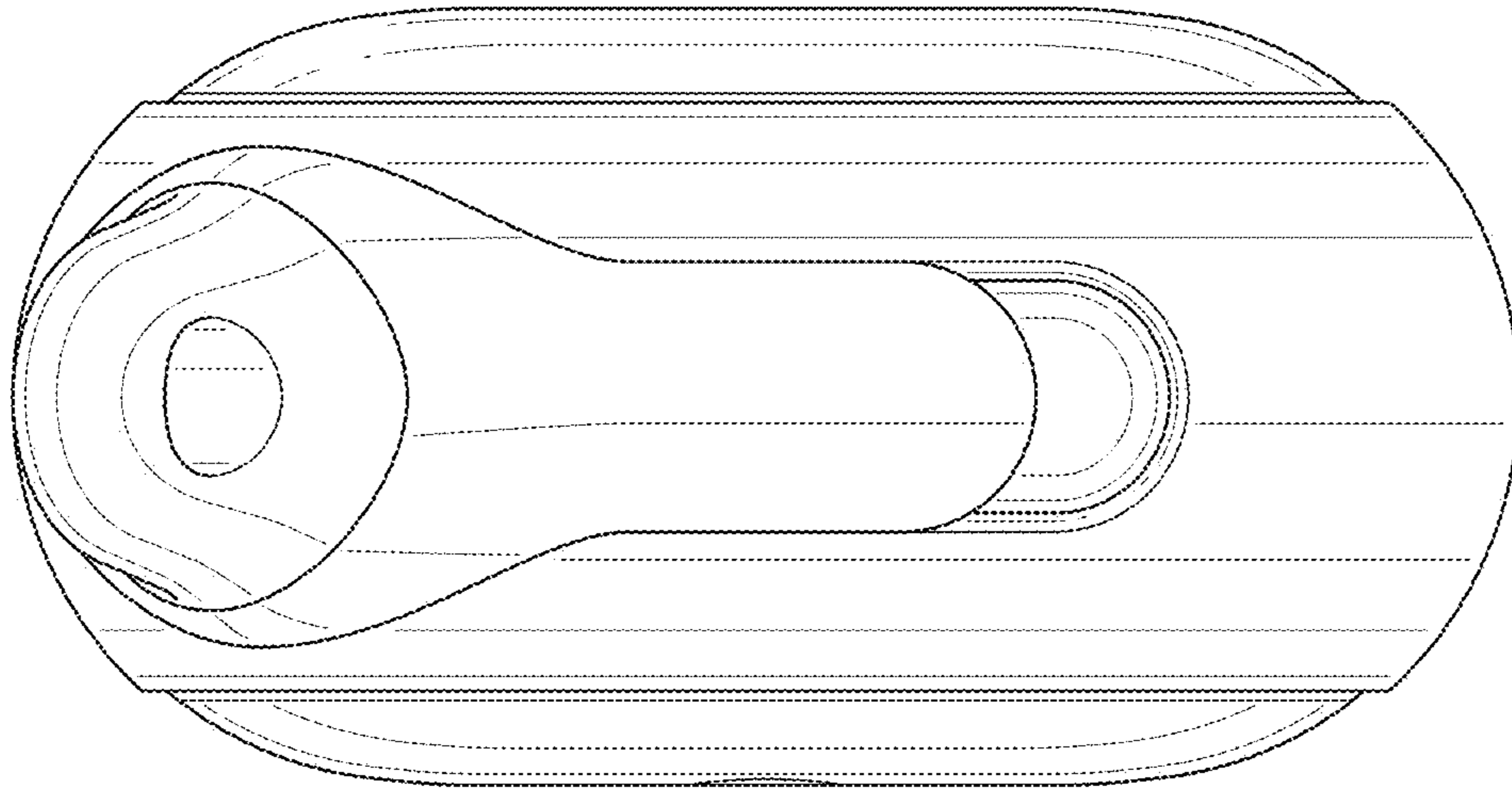

FIG. 104

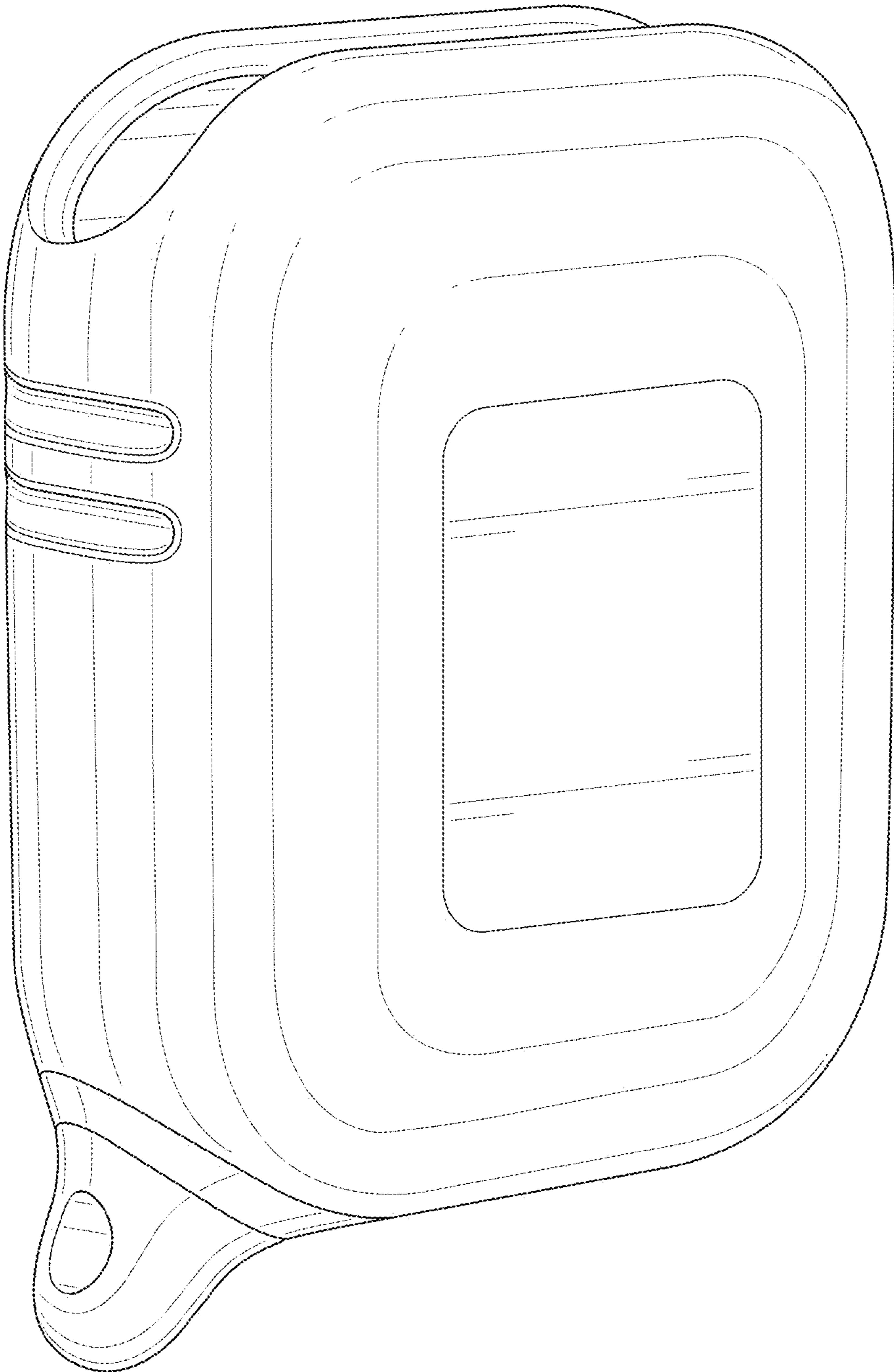

FIG. 105

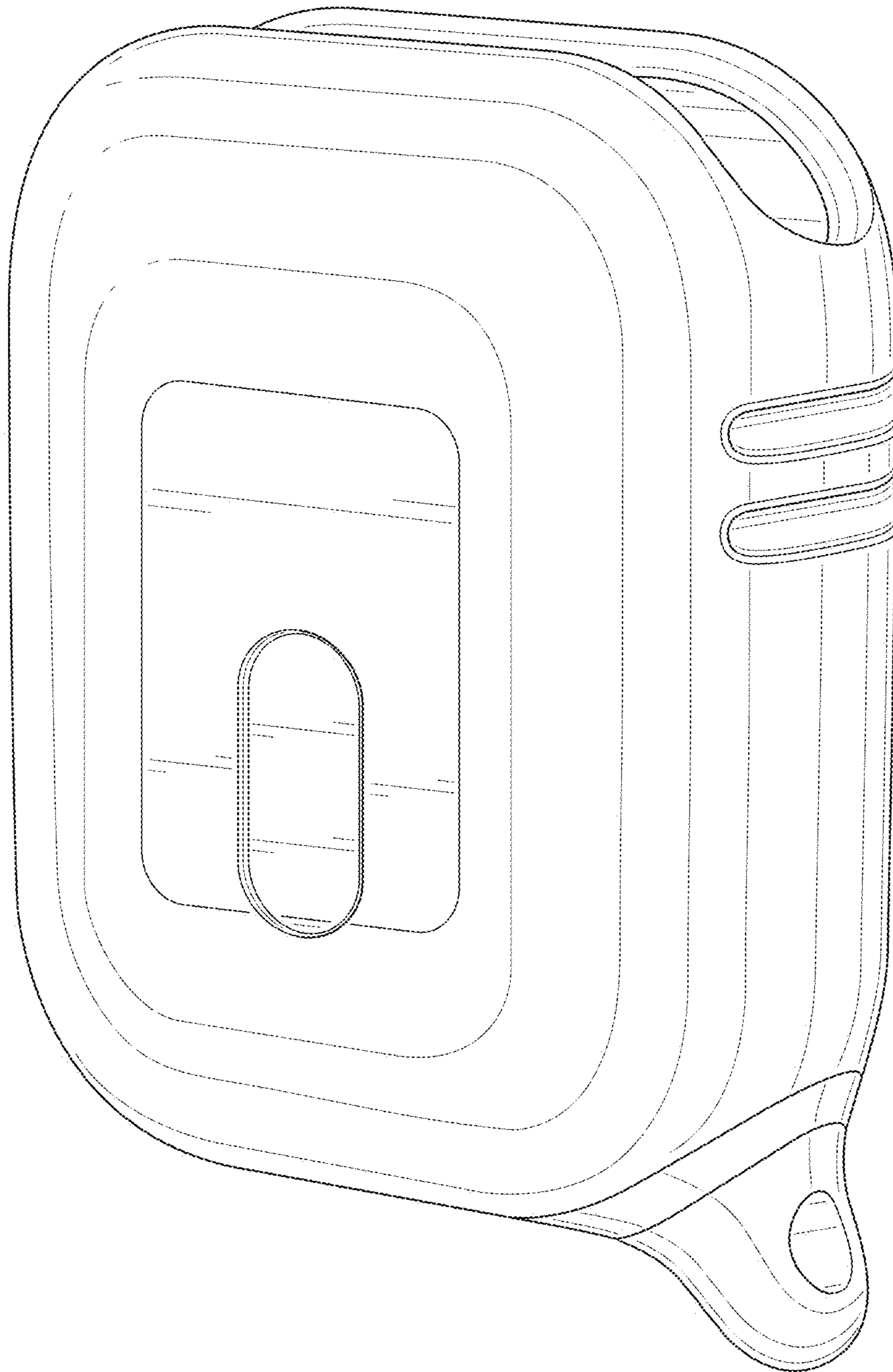

FIG. 106

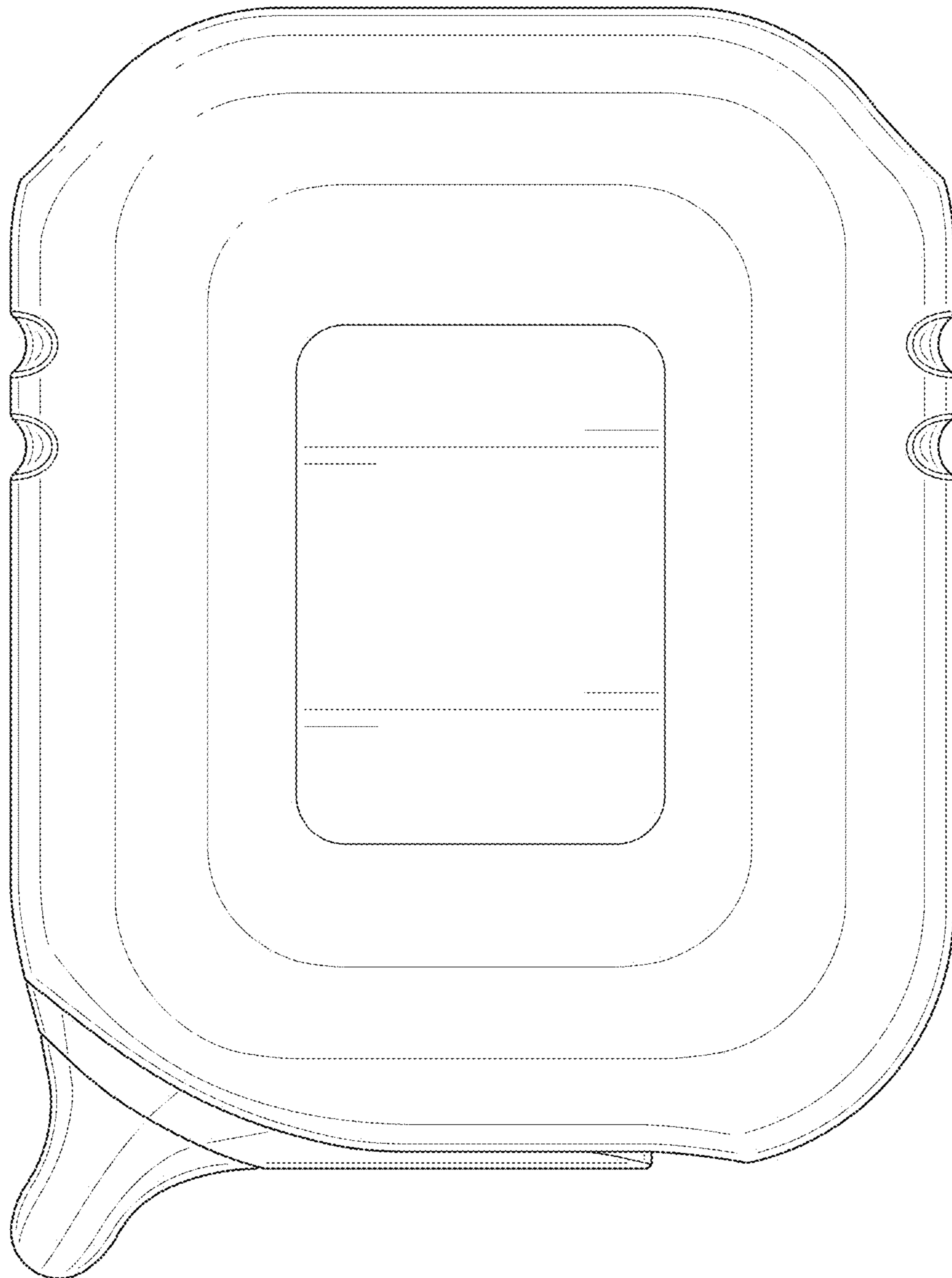

FIG. 107

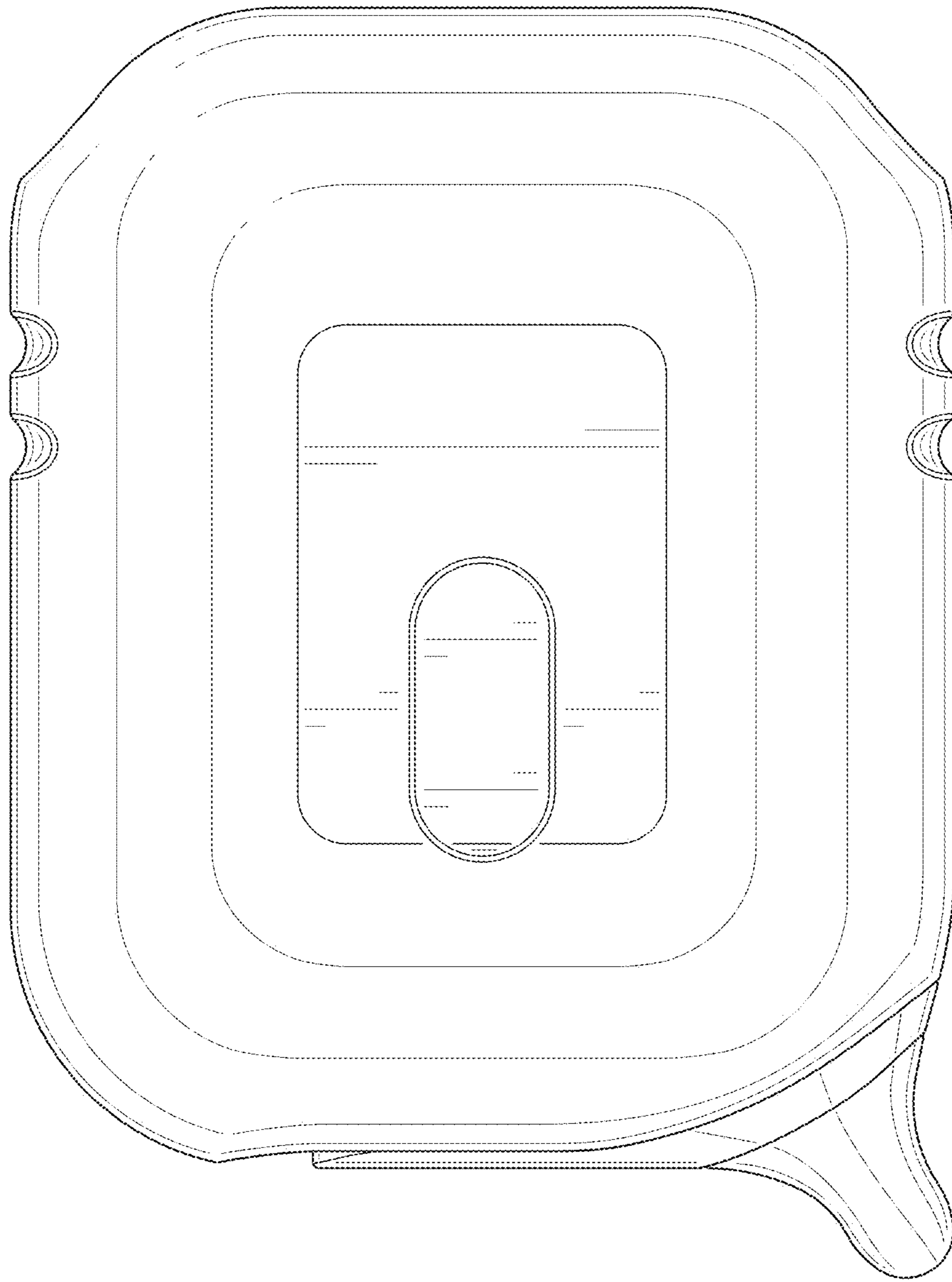

FIG. 108

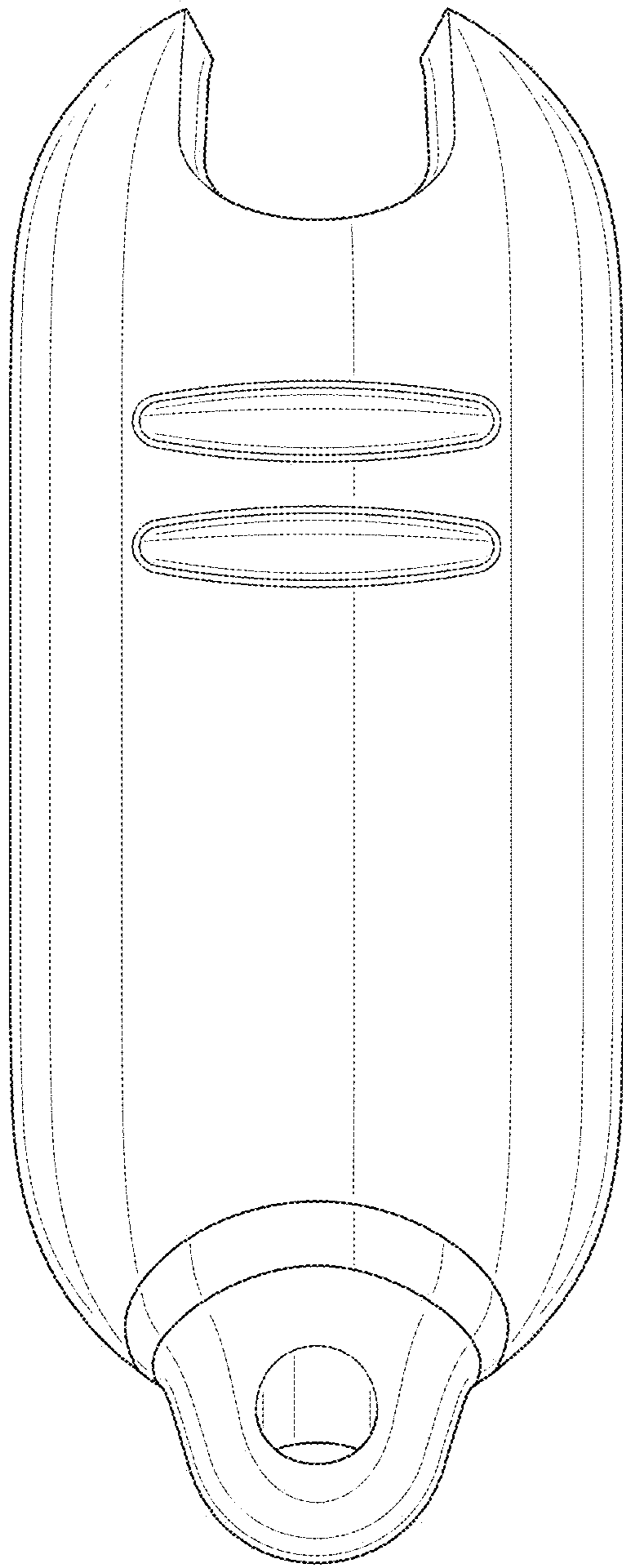

FIG. 109

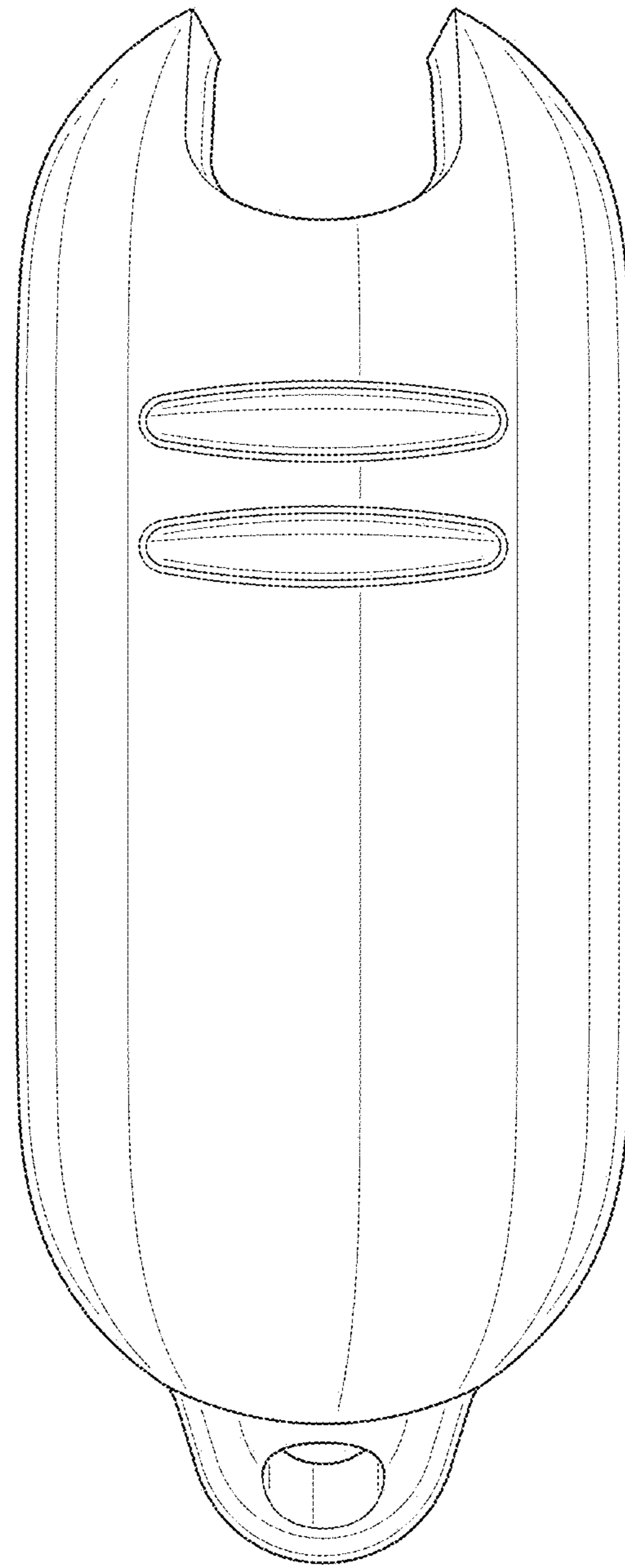

FIG. 110

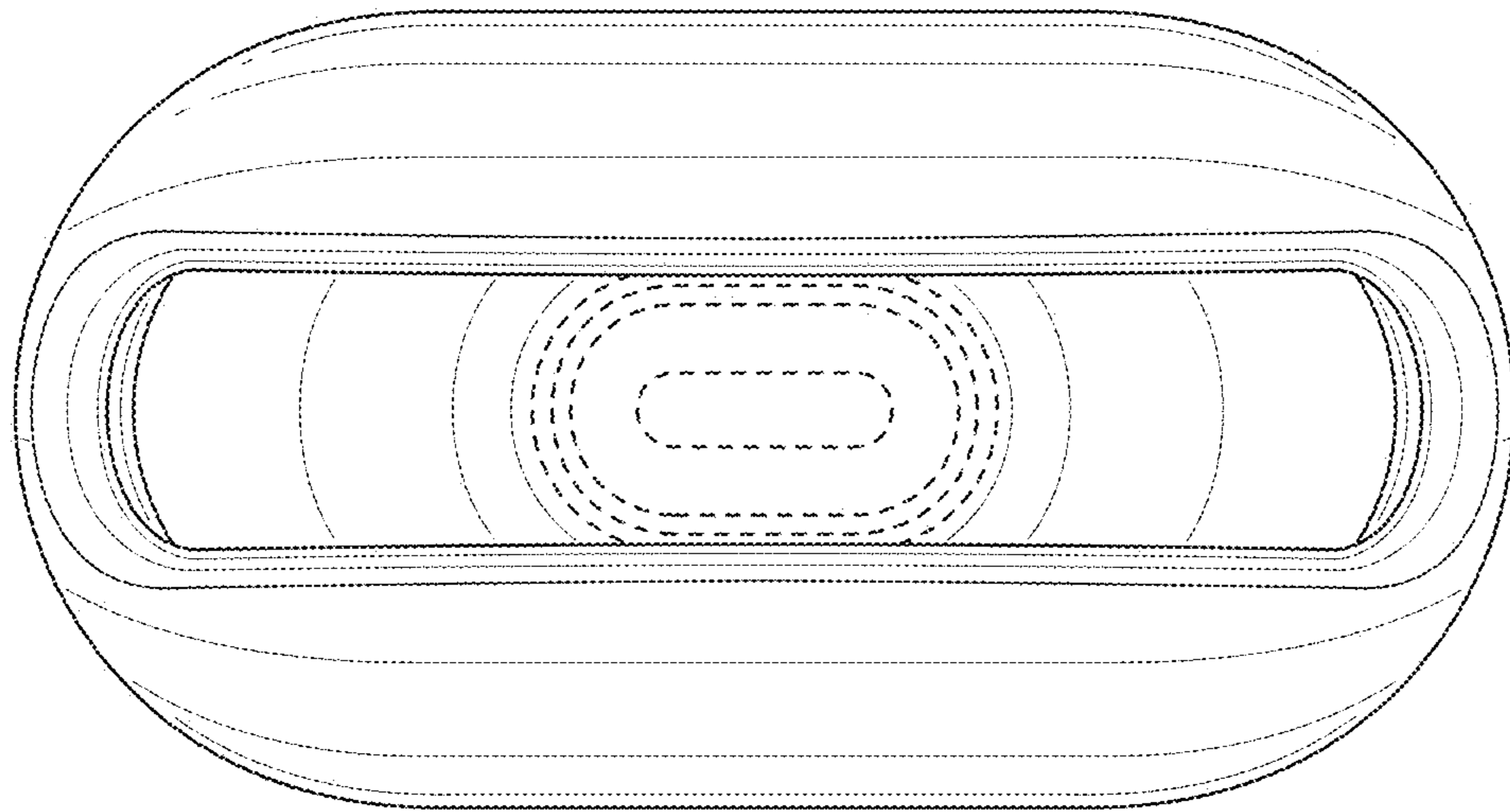

FIG. 111

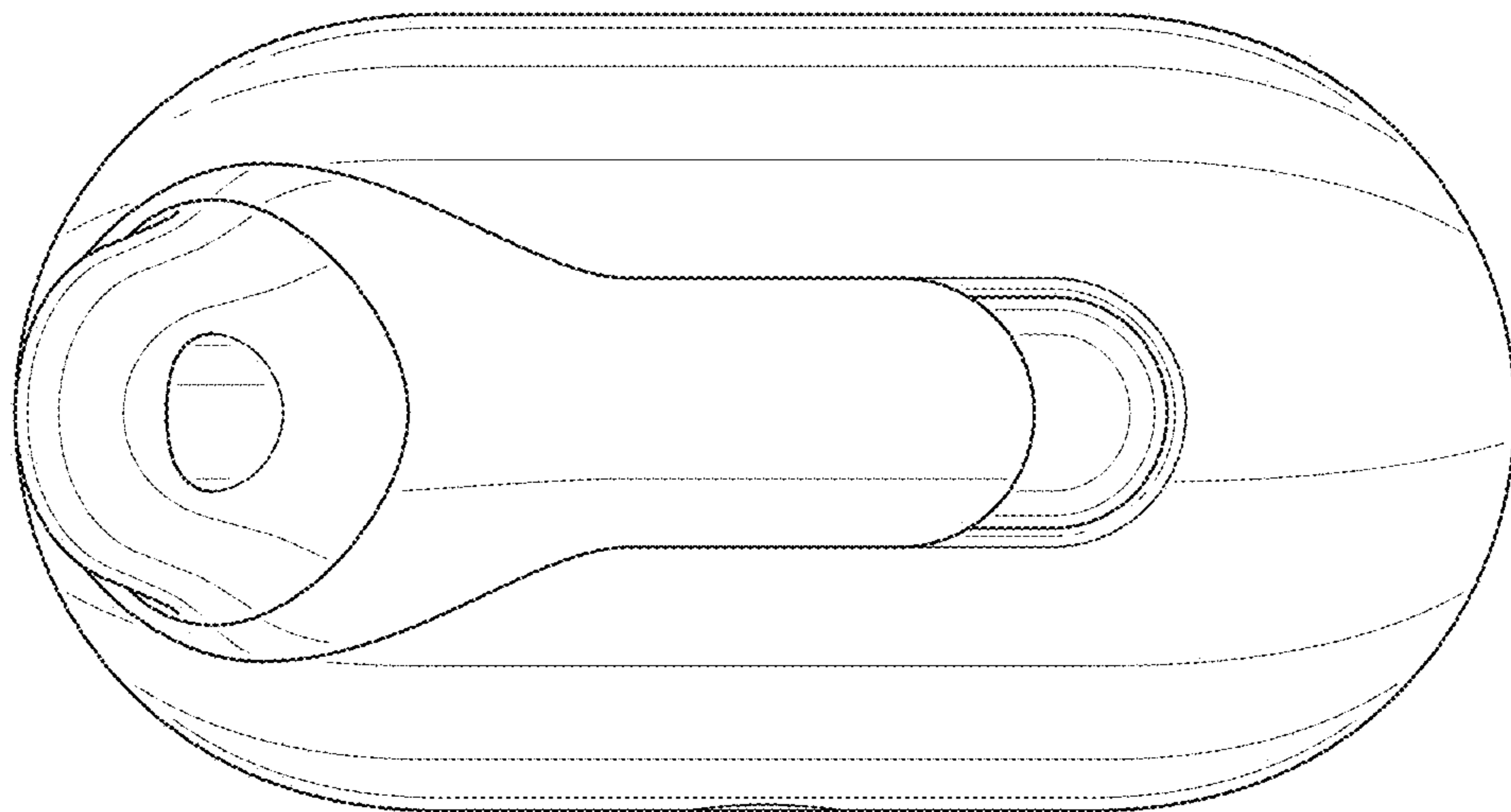

FIG. 112