



US00D942891S

(12) **United States Design Patent**  
**Montagano**

(10) **Patent No.:** **US D942,891 S**

(45) **Date of Patent:** **\*\* Feb. 8, 2022**

(54) **MESH TRAY**

(71) Applicant: **MONDI PRODUCTS LTD.,**  
Vancouver (CA)

(72) Inventor: **Michael Montagano,** Vancouver (CA)

(73) Assignee: **MONDI PRODUCTS LTD.,**  
Vancouver (CA)

(\*\*) Term: **15 Years**

(21) Appl. No.: **29/699,734**

(22) Filed: **Jul. 29, 2019**

(30) **Foreign Application Priority Data**

Apr. 24, 2019 (CA) ..... CA 187139

(51) **LOC (13) Cl.** ..... **11-02**

(52) **U.S. Cl.**  
USPC ..... **D11/155**

(58) **Field of Classification Search**  
USPC ..... D3/304, 315; D6/403, 404, 405, 680.2;  
D26/55

(Continued)

(56) **References Cited**

**U.S. PATENT DOCUMENTS**

D210,750 S \* 4/1968 Paxton ..... D11/155  
D259,777 S \* 7/1981 Ehrreich ..... D11/155

(Continued)

**OTHER PUBLICATIONS**

Monster Gardens website, Mondri black and white propagation tray,  
Publication date unknown, [site visited Feb. 21, 2021], Available on  
the Internet URL <https://monstergardens.com/mondi-black-and-white-propagation-tray-10-x-20-25-pack.html> (Year: 2021).\*

(Continued)

*Primary Examiner* — S. Bryan Reinholdt, Jr.

(74) *Attorney, Agent, or Firm* — Moore & Van Allen  
PLLC; Jeffrey R. Gray

(57) **CLAIM**

The ornamental design for a mesh tray, as shown and described.

**DESCRIPTION**

FIG. 1 is a front perspective view of a first variant of a mesh tray;

FIG. 2 is a front view of the mesh tray of FIG. 1;

FIG. 3 is a side elevation view of one side of the mesh tray of FIG. 1;

FIG. 4 is a side view of the mesh tray of FIG. 1;

FIG. 5 is a top perspective view of the mesh tray of FIG. 1;

FIG. 6 is an enlarged detail view of area 6 circumscribed within the mesh tray of FIG. 5;

FIG. 7 is a bottom perspective view of the mesh tray of FIG. 1;

FIG. 8 is a perspective view of the mesh tray of FIG. 1 in a use configuration with environment;

FIG. 9 is a perspective view of the mesh tray of FIG. 1 in a use configuration with environment;

FIG. 10 is a front perspective view of a second embodiment of a mesh tray;

FIG. 11 is a front view of the mesh tray of FIG. 10;

FIG. 12 is a side elevation view of one side of the mesh tray of FIG. 10;

FIG. 13 is a side view of the mesh tray of FIG. 10;

FIG. 14 is a top perspective view of the mesh tray of FIG. 10;

FIG. 15 is an enlarged detail view of area 15 circumscribed within the mesh tray of FIG. 14;

FIG. 16 is a bottom perspective view of the mesh tray of FIG. 10;

FIG. 17 is a perspective view of the mesh tray of FIG. 10 in a use configuration with environment;

FIG. 18 is a perspective view of a mesh tray of FIG. 10 in a use configuration with environment;

FIG. 19 is a front perspective view of a third embodiment of a mesh tray;

FIG. 20 is a front view of the mesh tray of FIG. 19;

(Continued)

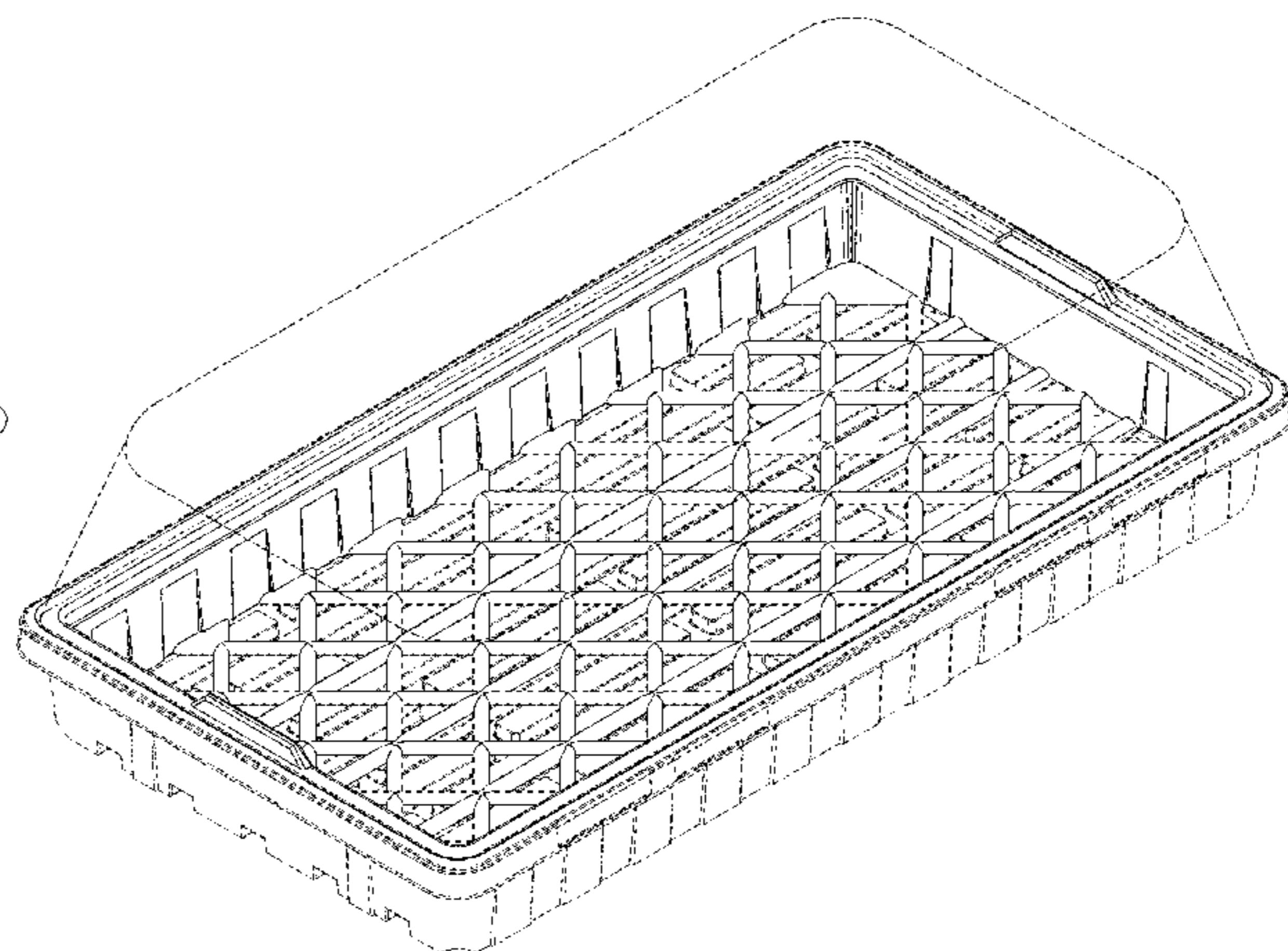
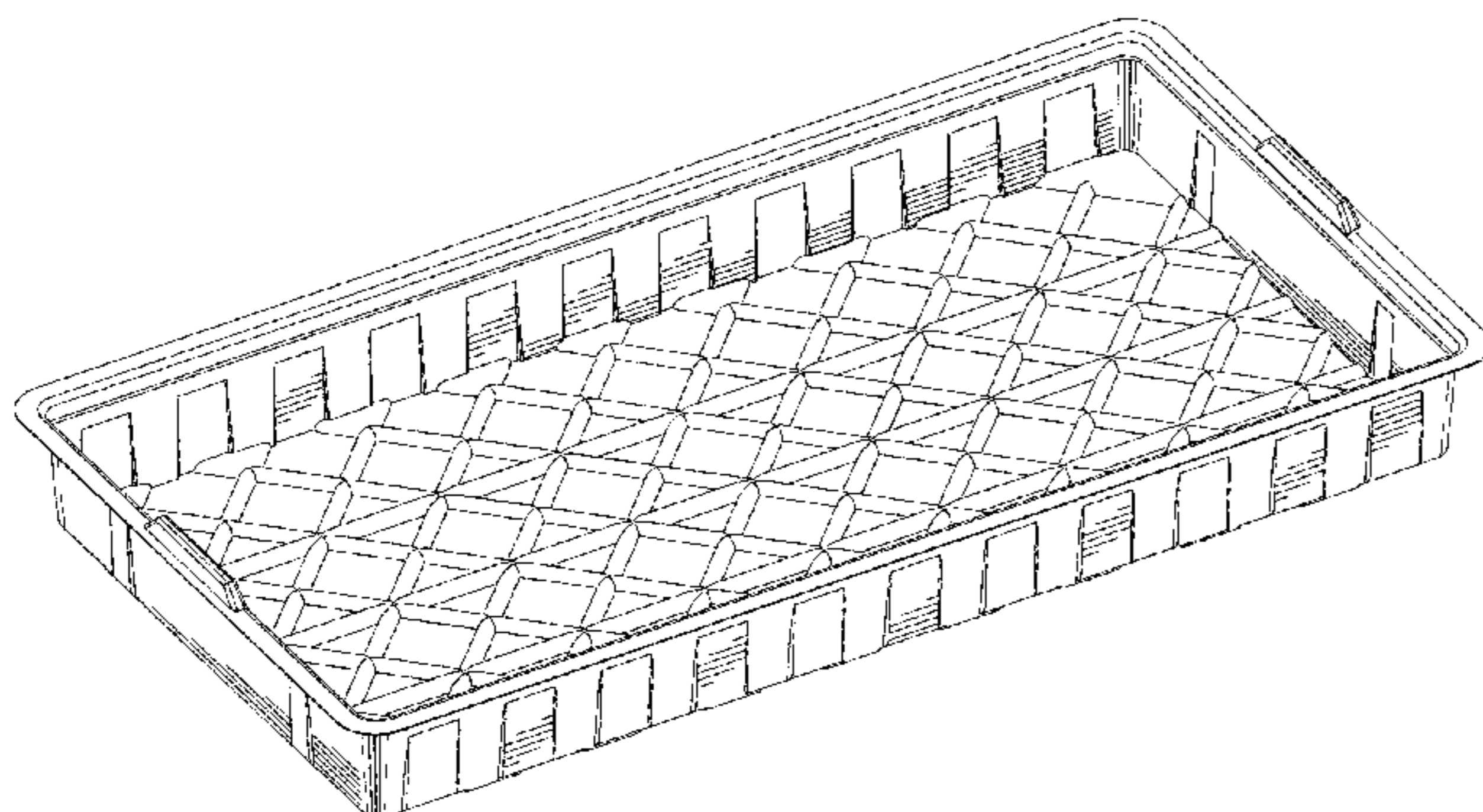

FIG. 21 is a side elevation view of one side of the mesh tray of FIG. 19;  
 FIG. 22 is a side view of the mesh tray of FIG. 19;  
 FIG. 23 is a top perspective view of the mesh tray of FIG. 19;  
 FIG. 24 is an enlarged detail view of area 26 circumscribed within the mesh tray of FIG. 23;  
 FIG. 25 is a bottom perspective view of the mesh tray of FIG. 19;  
 FIG. 26 is a perspective view of a mesh tray of FIG. 19 in a use configuration with environment; and,  
 FIG. 27 is a perspective view of a mesh tray of FIG. 19 in a use configuration with environment.  
 The dot-dash-dot broken lines in FIGS. 5, 6, 14, 15, 23, and 24 depict the boundaries of the enlargements that form no part of the claimed design. The evenly spaced broken lines in FIGS. 8, 17, and 26 depict environment of a propagation tray that forms no part of the claimed design. The evenly spaced broken lines in FIGS. 9, 18, and 27 depict environment of a propagation tray and cover that form no part of the claimed design.

**1 Claim, 21 Drawing Sheets**

(58) **Field of Classification Search**

CPC ..... A01G 9/02  
 See application file for complete search history.

(56) **References Cited**

U.S. PATENT DOCUMENTS

D259,867 S \* 7/1981 Kenyon ..... D11/155  
 4,349,124 A \* 9/1982 Faller ..... B65D 1/44  
 220/608

D463,202 S \* 9/2002 Smith ..... D7/359  
 D558,453 S \* 1/2008 Richter ..... D3/304  
 D653,158 S \* 1/2012 Wardenburg ..... D11/145  
 D654,162 S \* 2/2012 Sykes ..... D23/393  
 D727,791 S \* 4/2015 Montagano ..... D11/155  
 D750,996 S \* 3/2016 Butler ..... D11/155  
 D793,161 S \* 8/2017 Fullmer ..... D7/409  
 D831,532 S \* 10/2018 Larsen ..... D11/143  
 2016/0143235 A1\* 5/2016 Torres ..... A01G 31/02  
 47/60

OTHER PUBLICATIONS

Mondi website, Propagation Tray 1020, Earliest publication date on wayback machine Oct. 27, 2020, [site visited Feb. 21, 2021], Available on the Internet URL <https://web.archive.org/web/20201027061831/https://mondiproducts.com/product/propagation-tray-1020-no-holes/> (Year: 2020).\*

Growershouse website, Mondi Propagation Trays 10x20 with Holes, Publication date unknown, [site visited Feb. 21, 2021], Available on the Internet URL <https://growershouse.com/mondi-propagation-trays-10-x-20-with-holes> (Year: 2021).\*

Amazon website, Mondi 10"x20" Tray, Earliest comment date Mar. 27, 2017, [site visited Feb. 21, 2021], Available on the Internet URL <https://www.amazon.com/Mondi-Tray-Humidity-Dome-Propagation/dp/B01N1V1DWB> (Year: 2017).\*

Amazon website, 1020 mesh bottom trays 5 pack, Date first available on Amazon Jun. 4, 2020, [site visited Jul. 24, 2021], Available on the Internet URL <https://www.amazon.com/1020-Mesh-Bottom-Trays-Pack/dp/B089Q6GZ6> (Year: 2020).\*

Mondi products website, Mesh tray 1020, Earliest date from the Wayback Machine Oct. 26, 2020, [site visited Jul. 24, 2021], Available on the Internet URL <https://web.archive.org/web/20201026181911/https://mondiproducts.com/product/mesh-tray-1020/> (Year: 2020).\*

\* cited by examiner

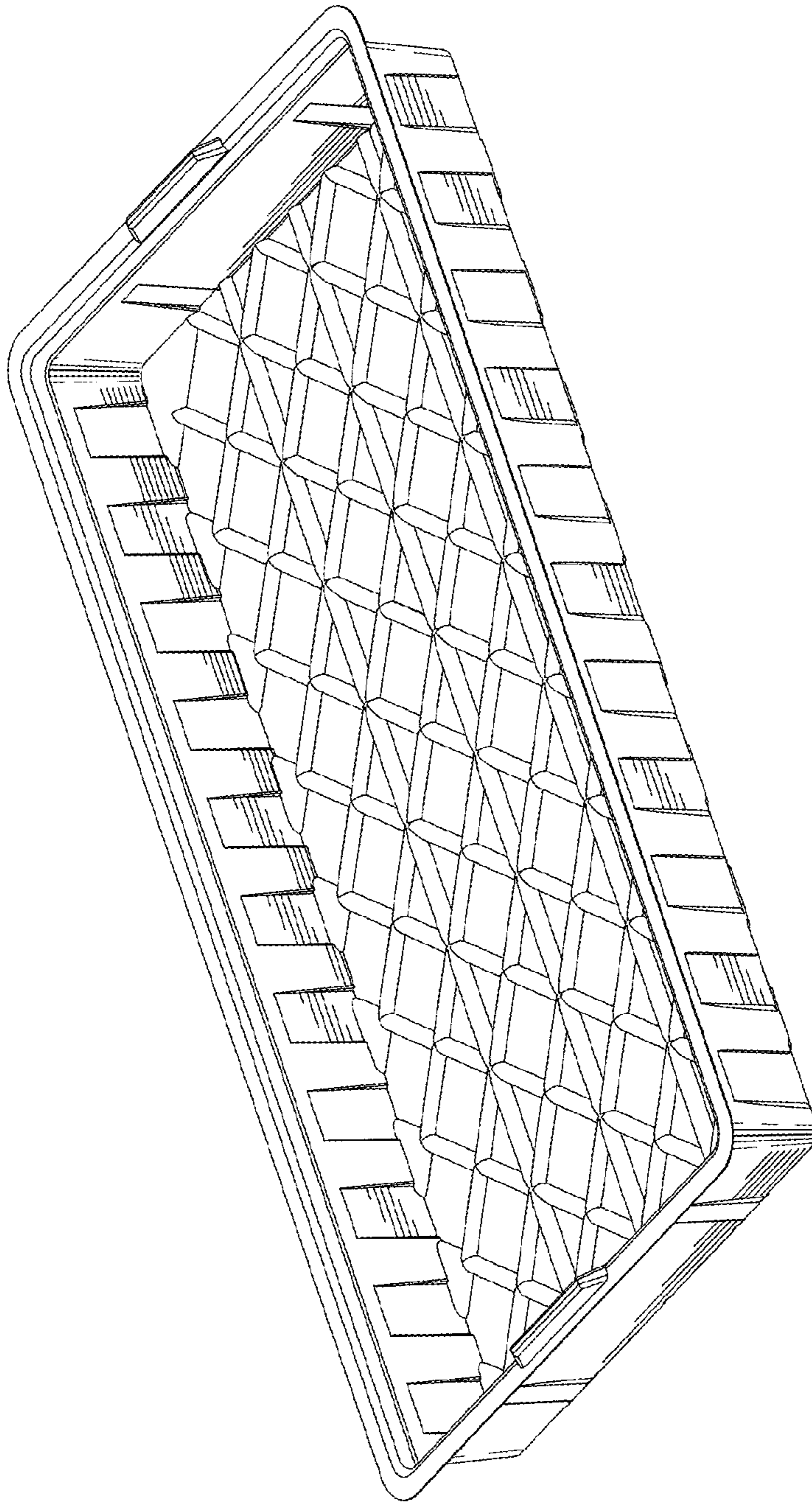

FIG. 1

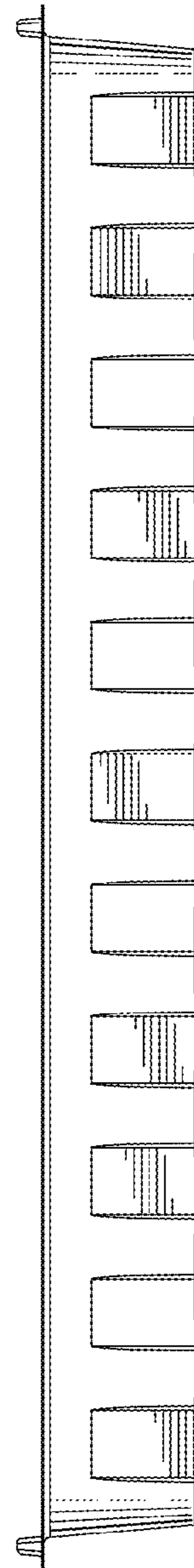

FIG. 2

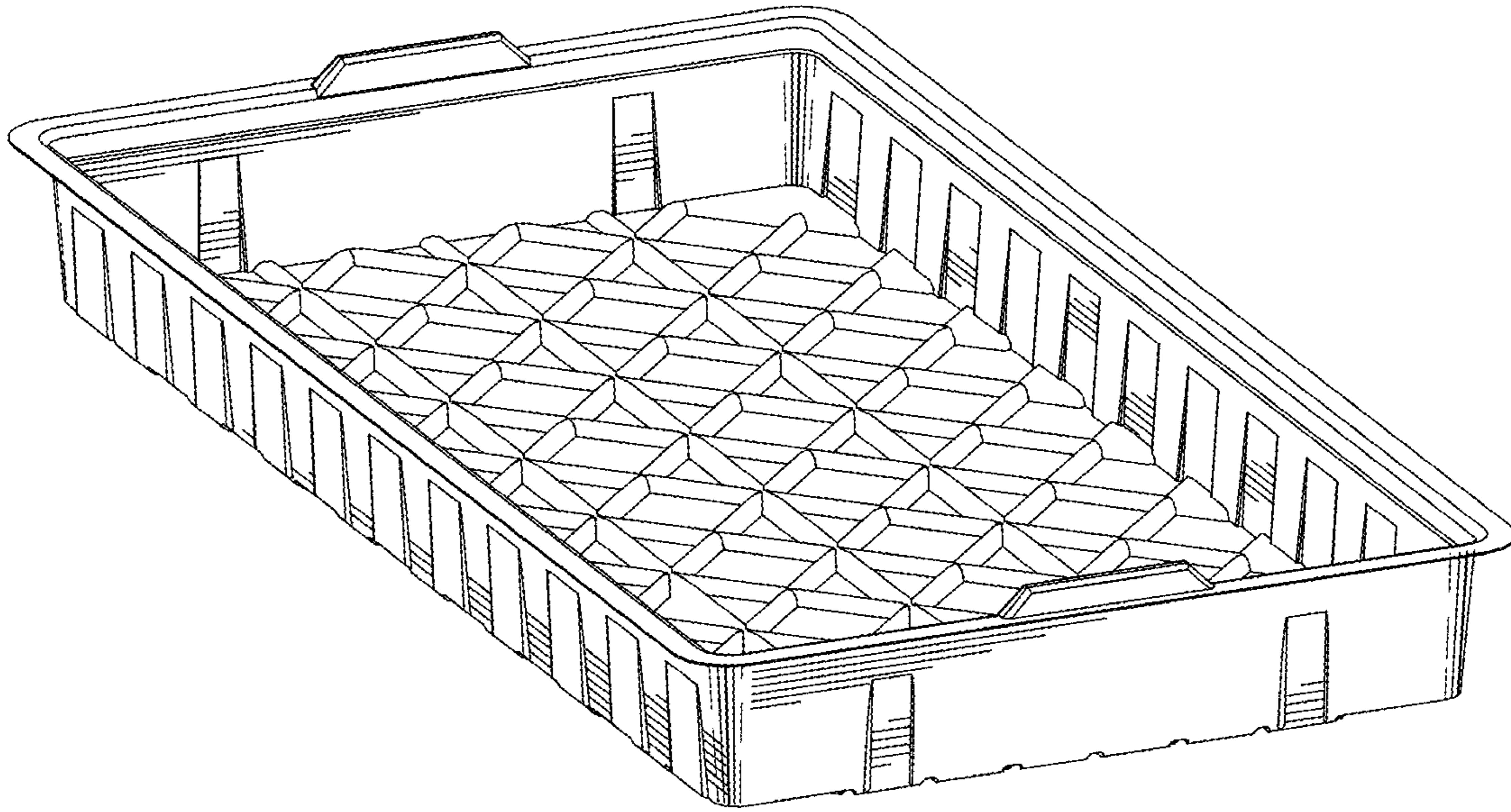

FIG. 3

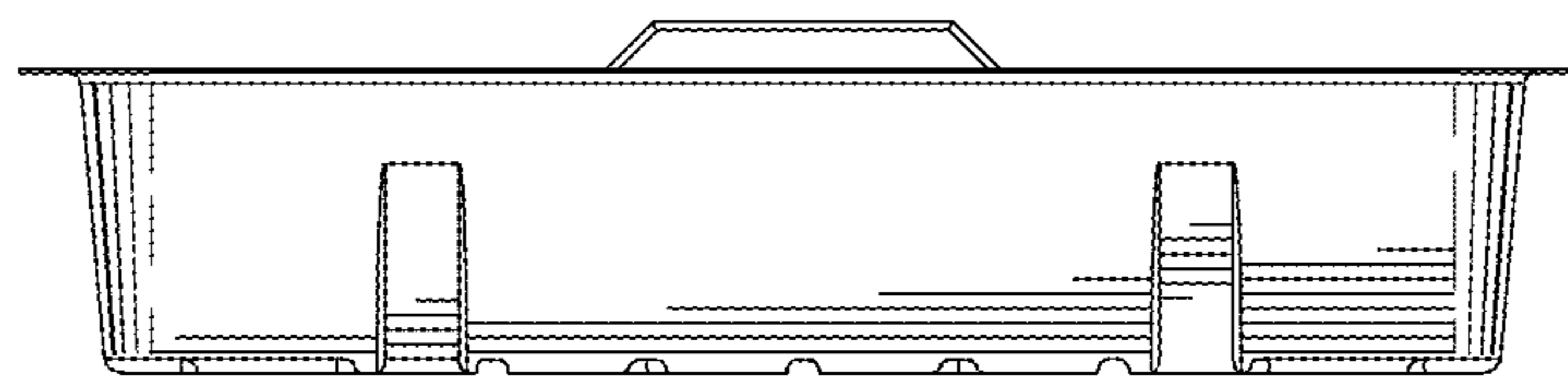

FIG. 4

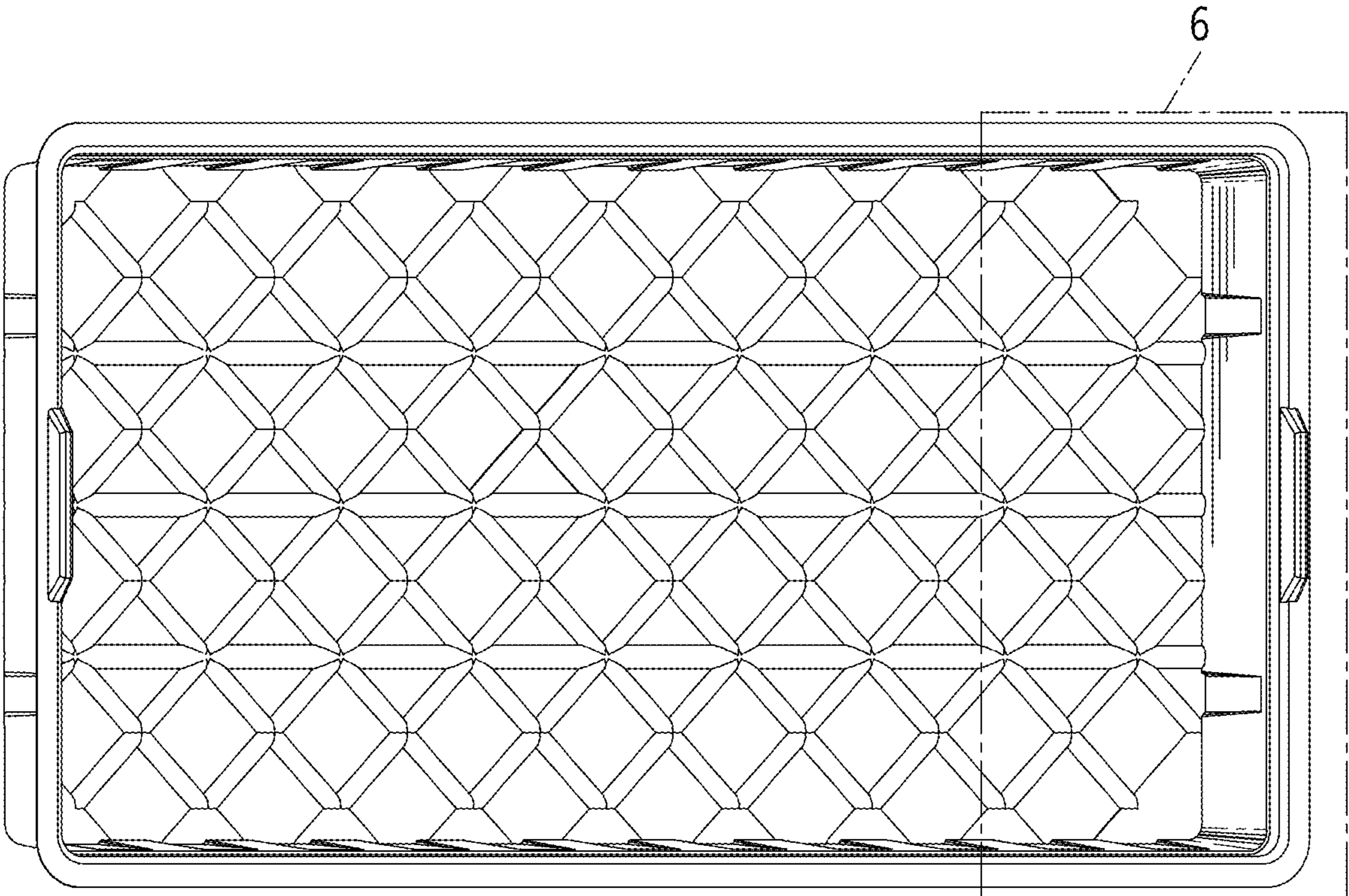

FIG. 5

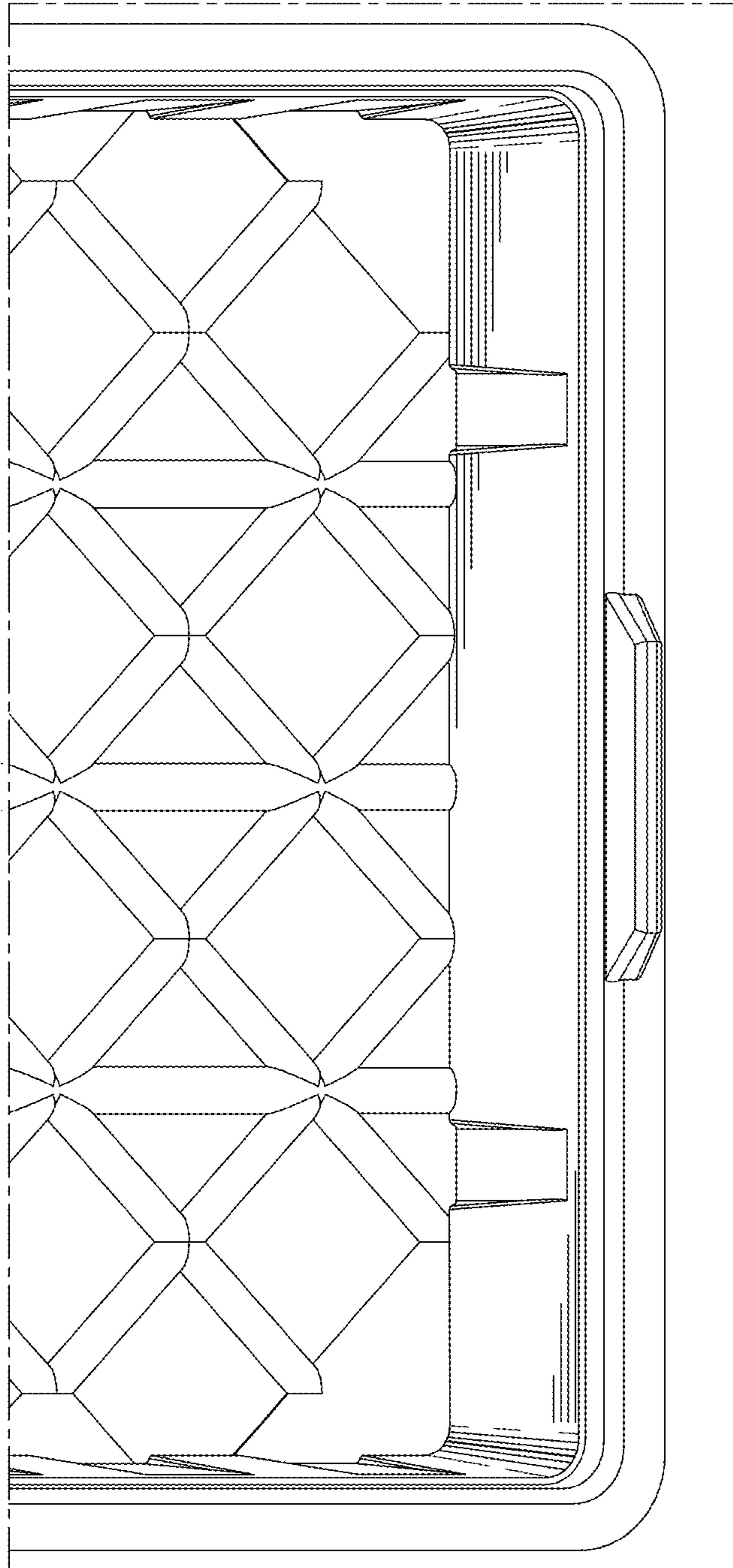

FIG. 6

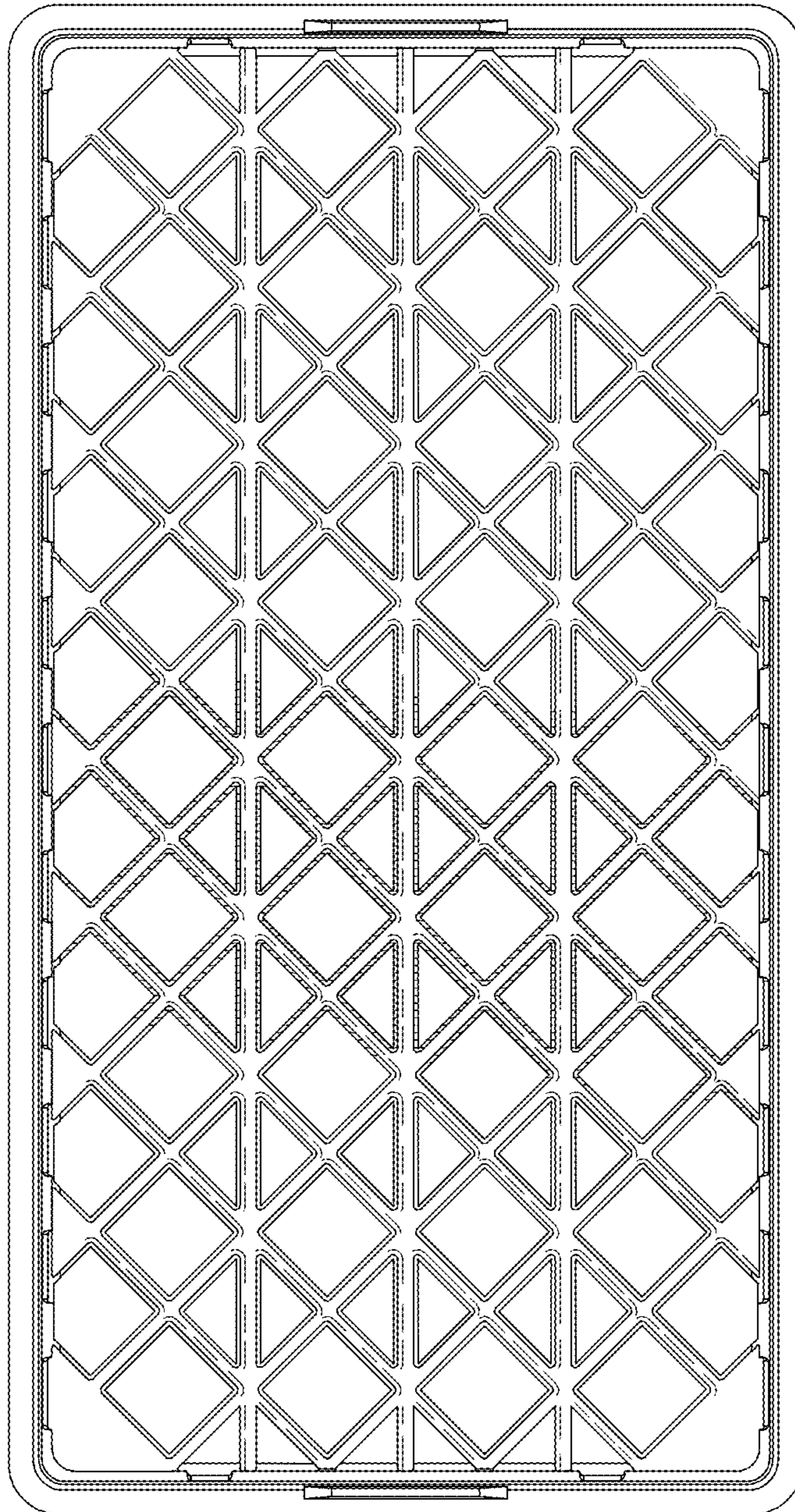

FIG. 7

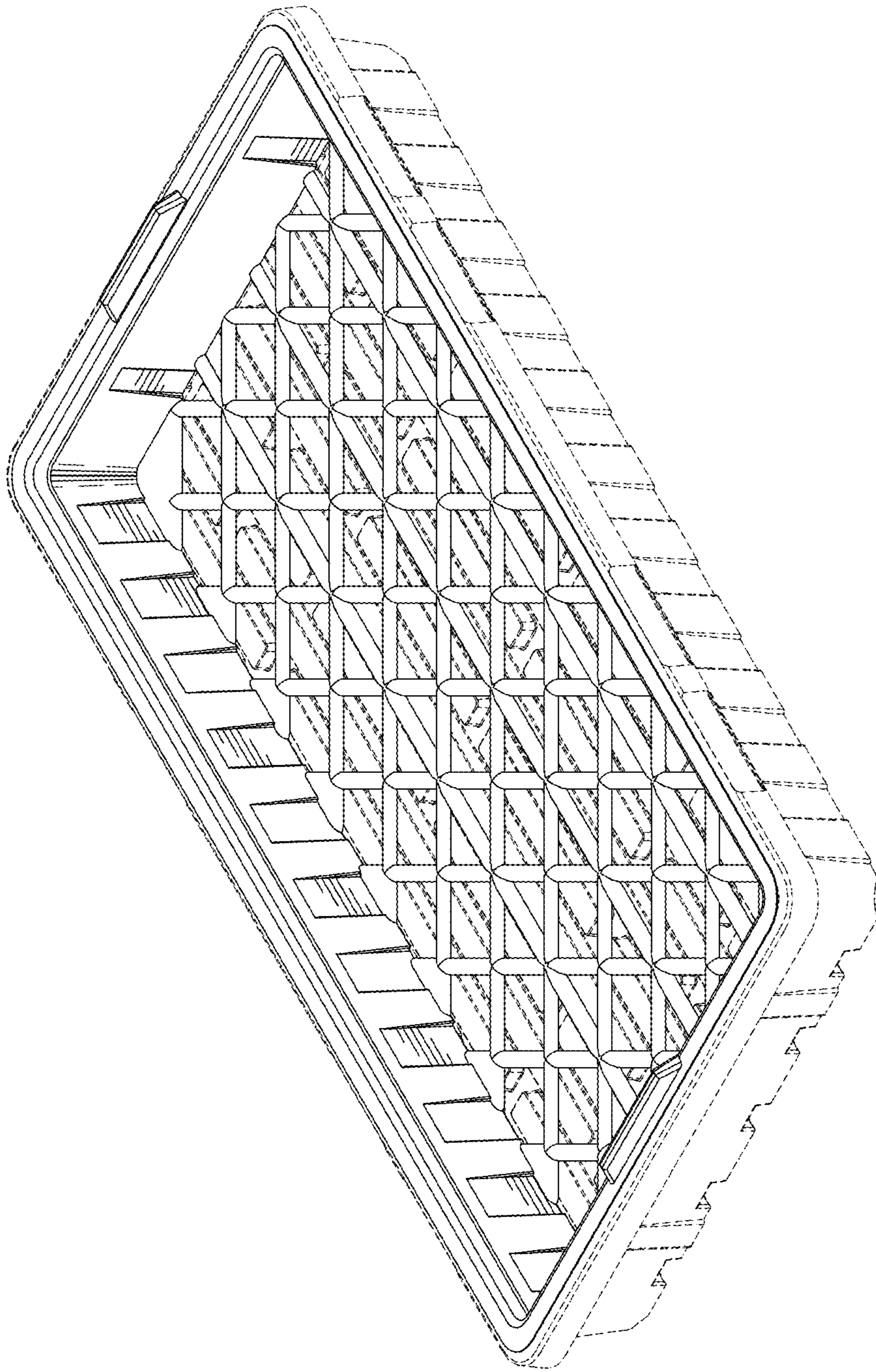

FIG. 6



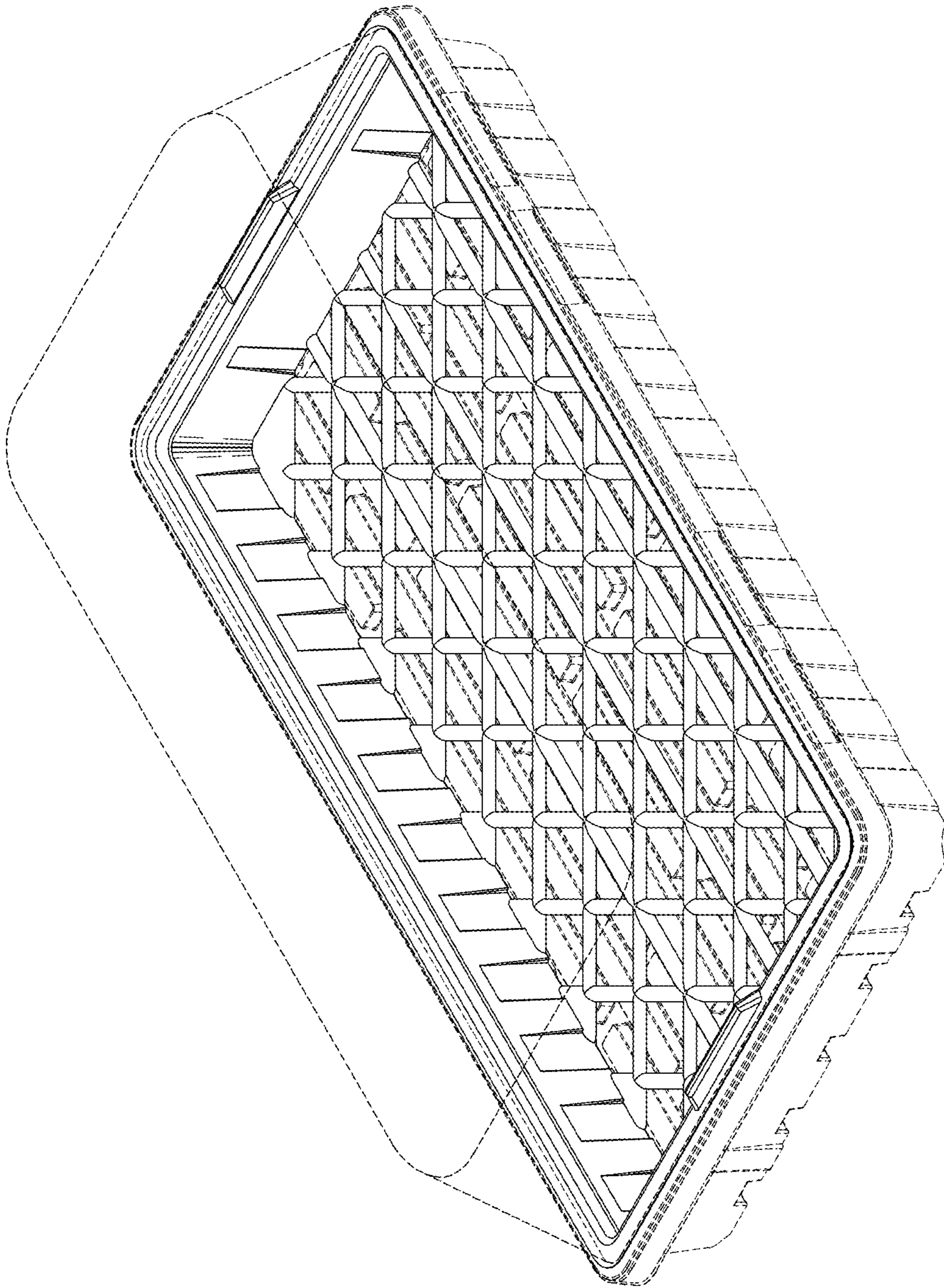

FIG. 7

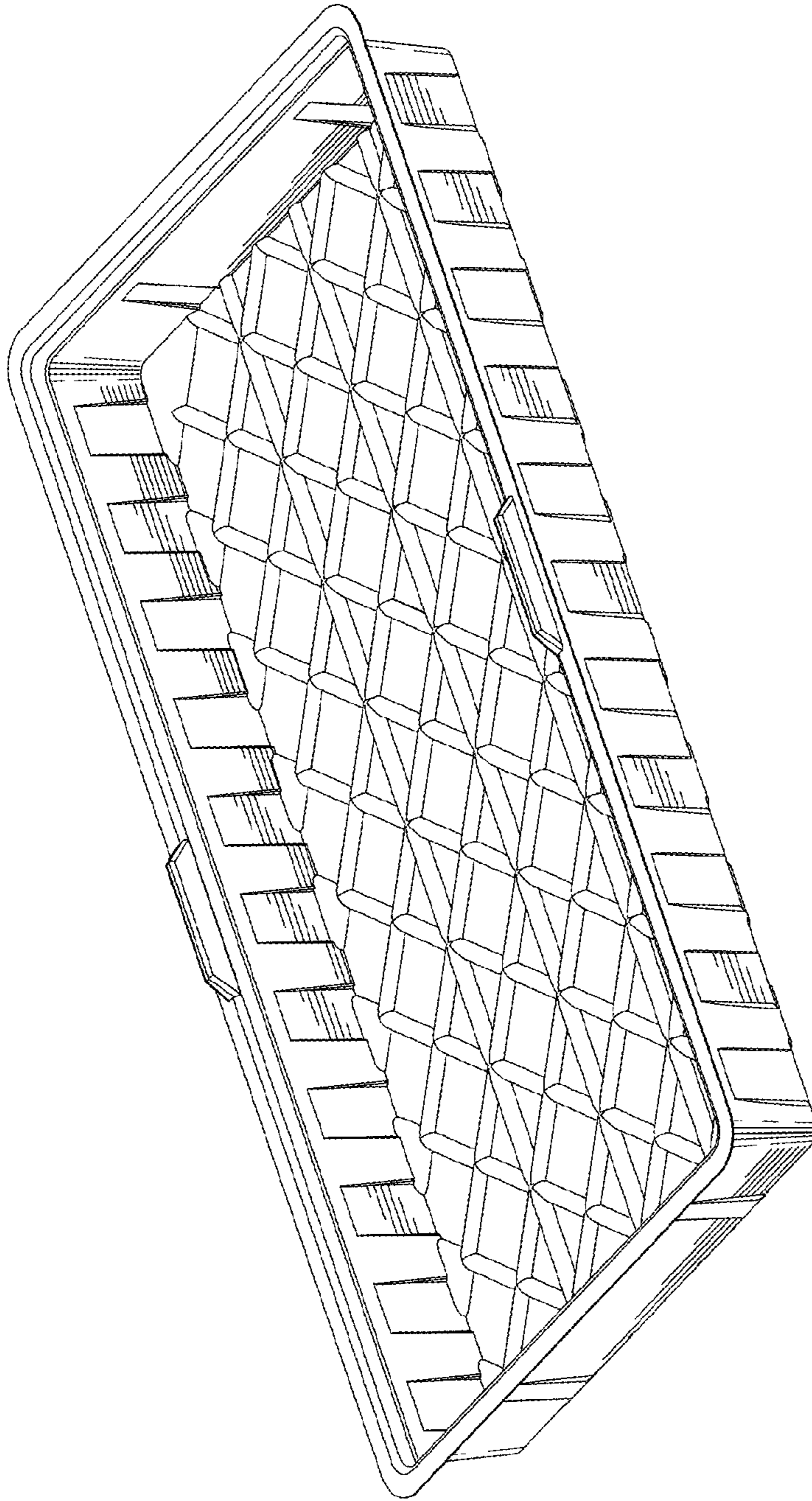

FIG. 10

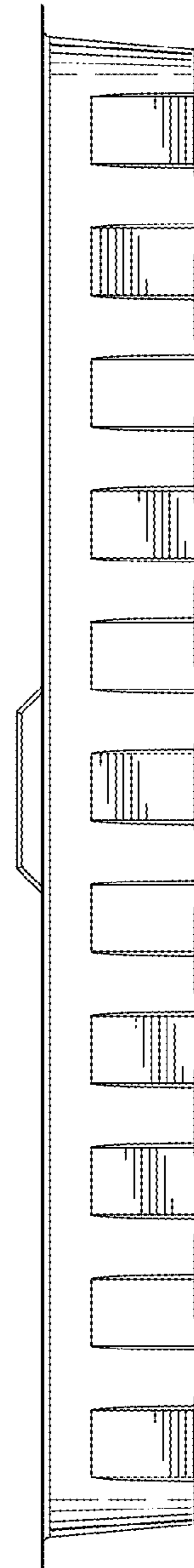

FIG. 11

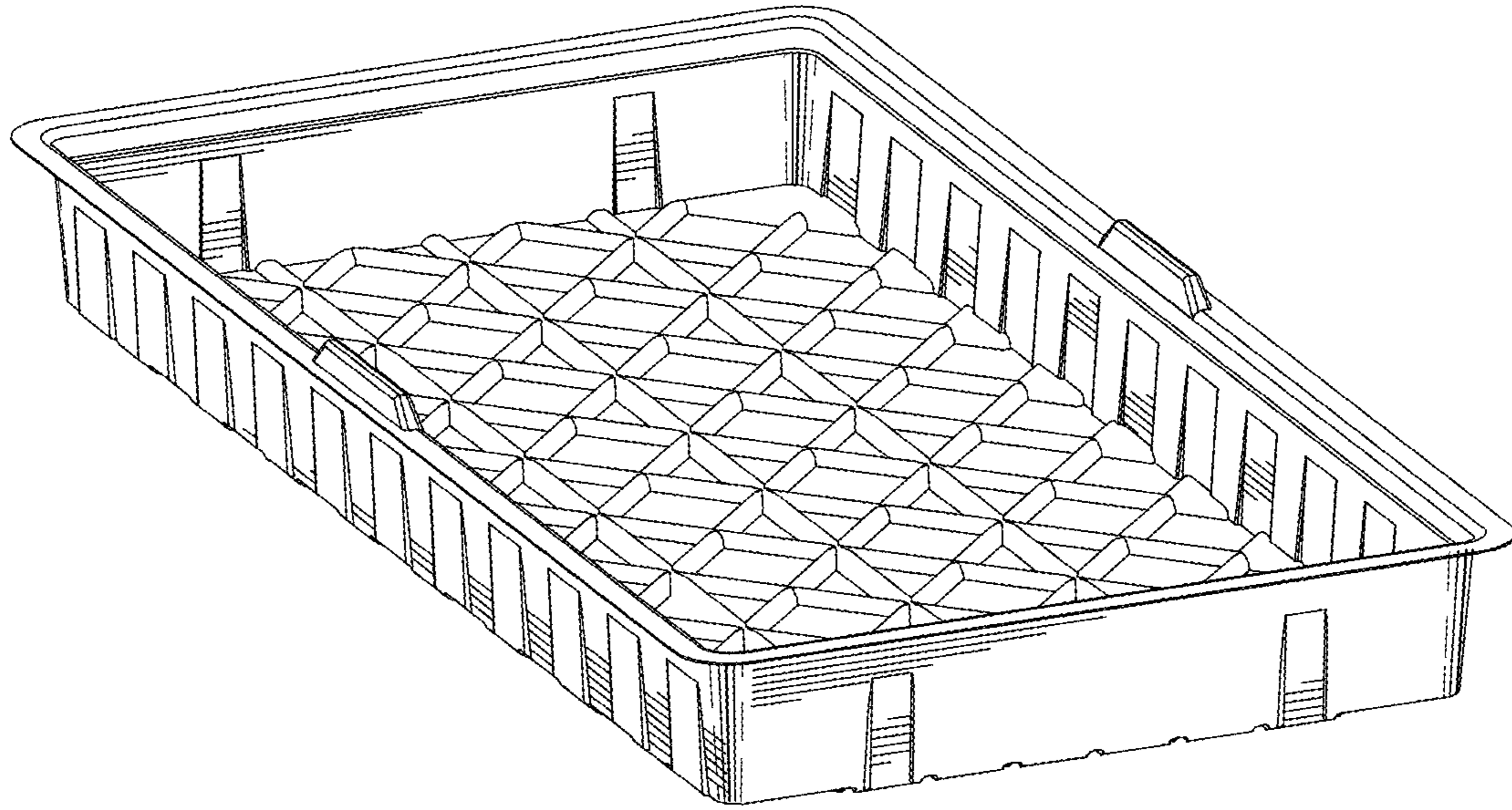

FIG. 12

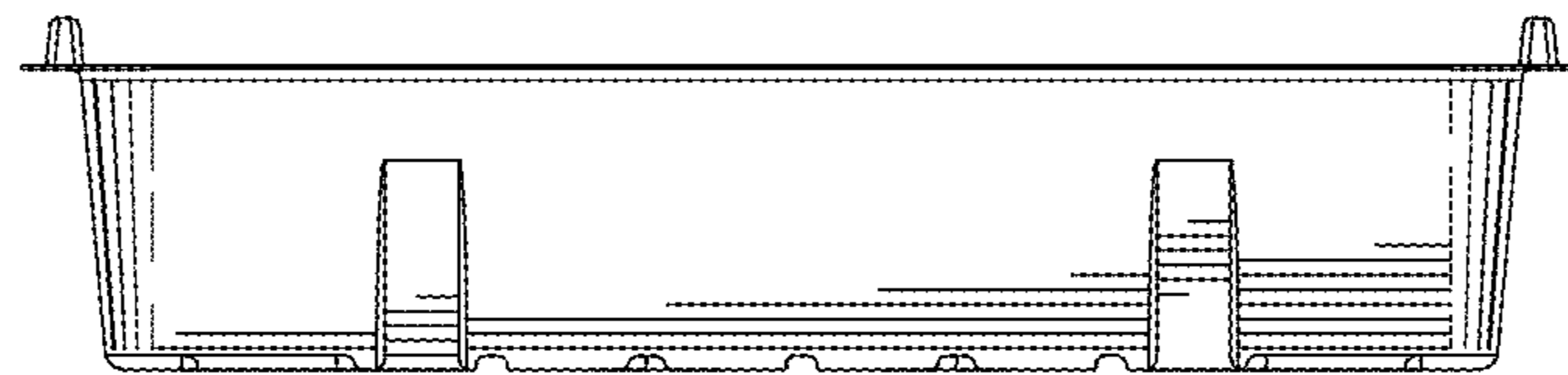

FIG. 13

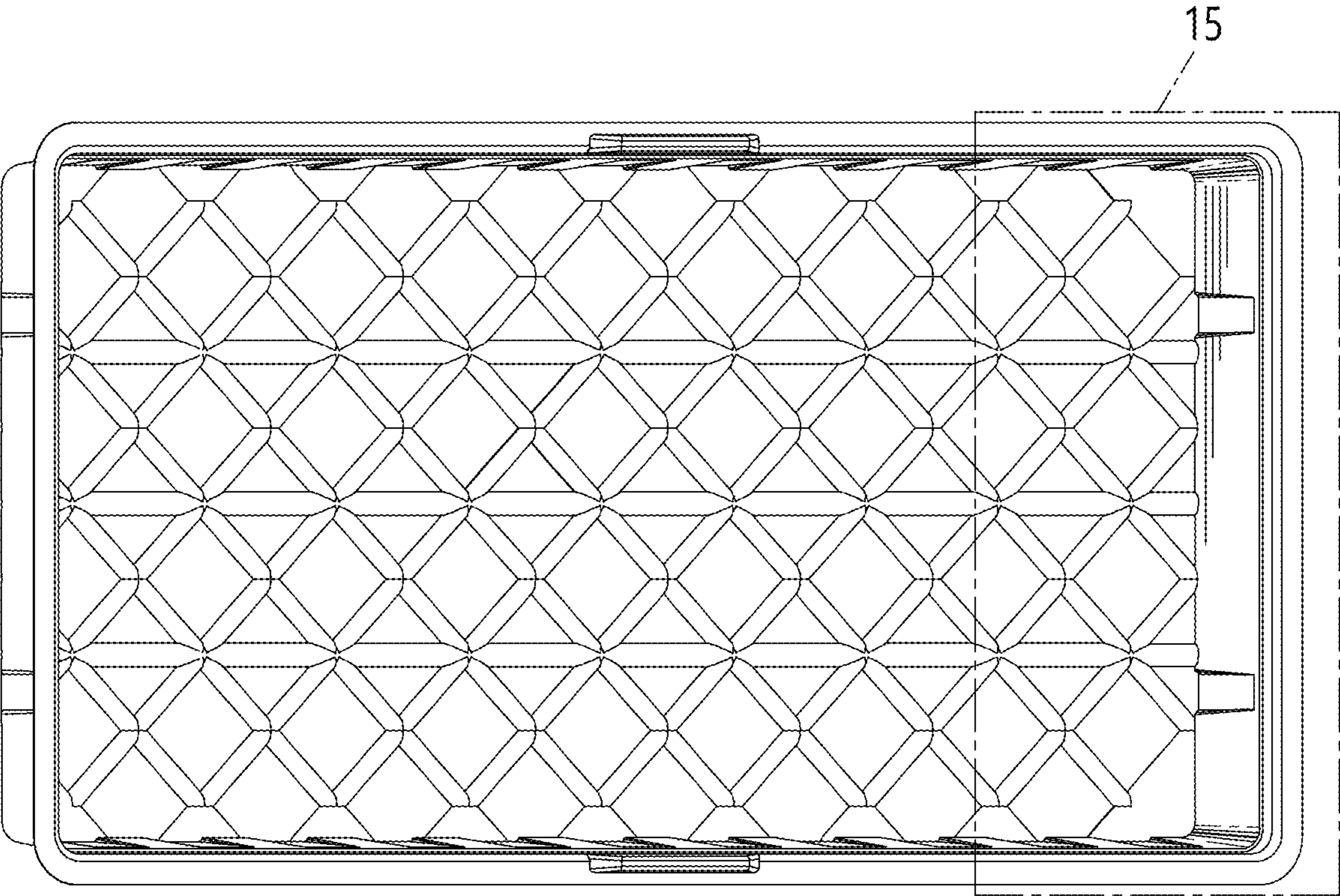

FIG. 14

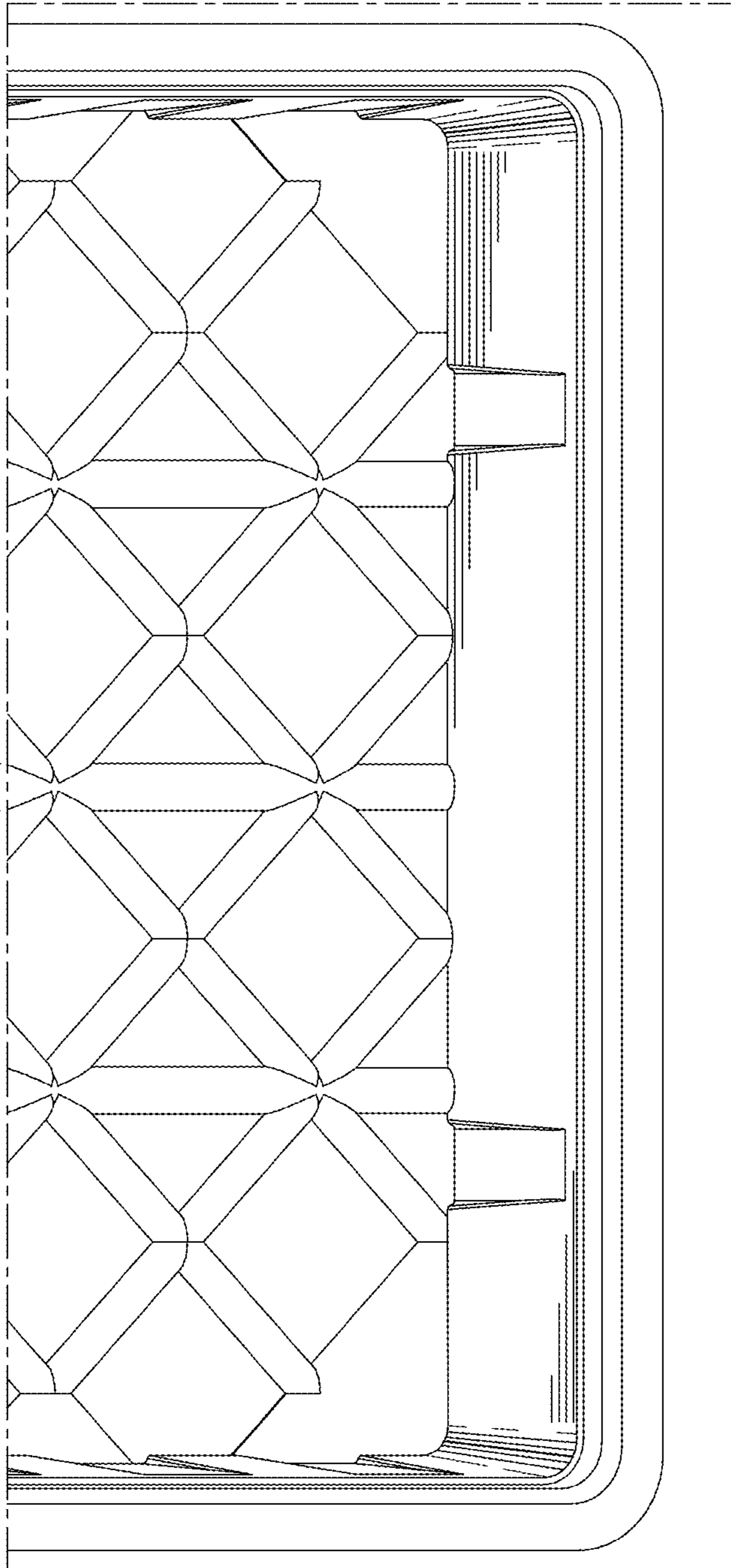

FIG. 15

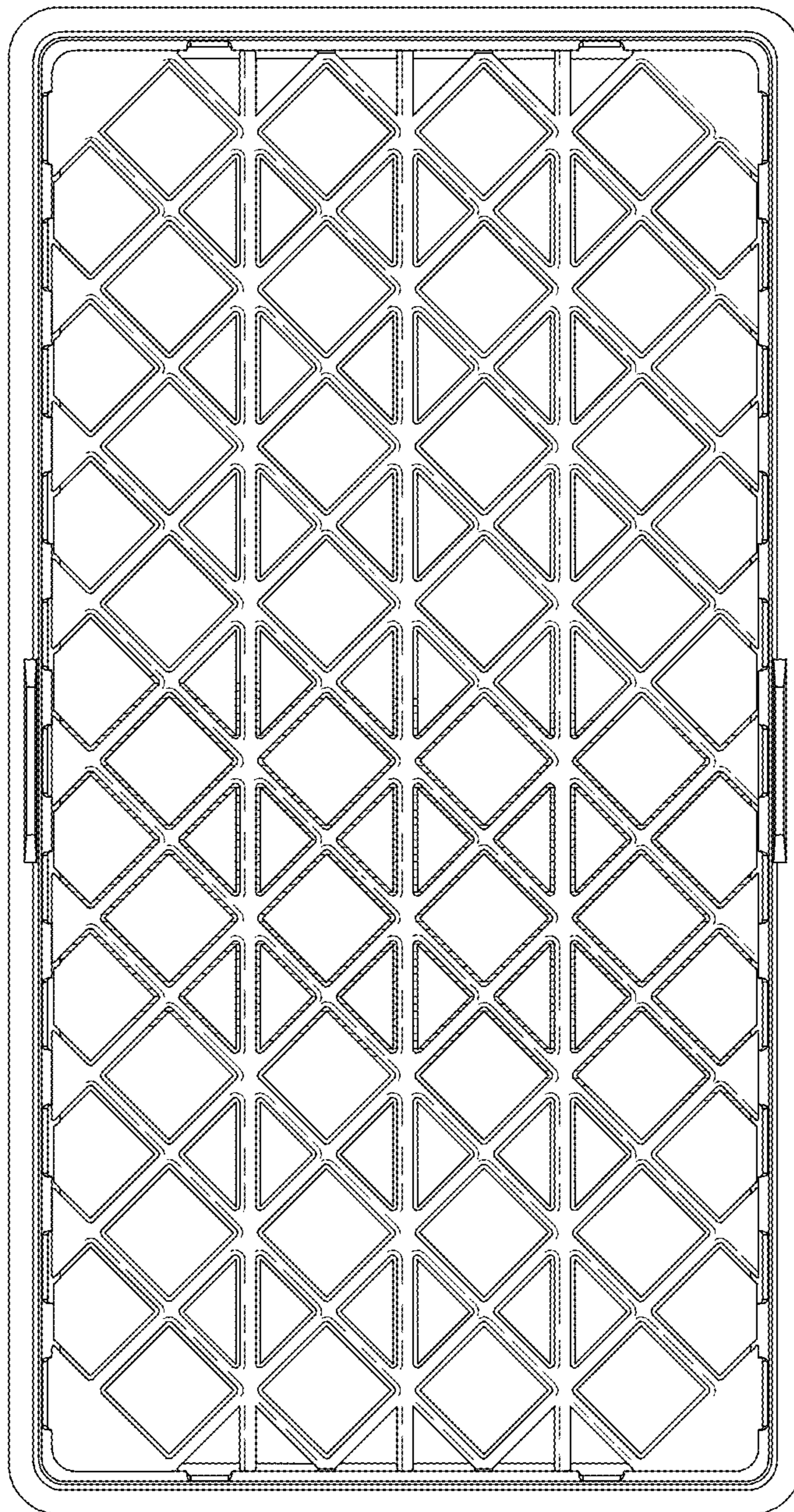

FIG. 1B

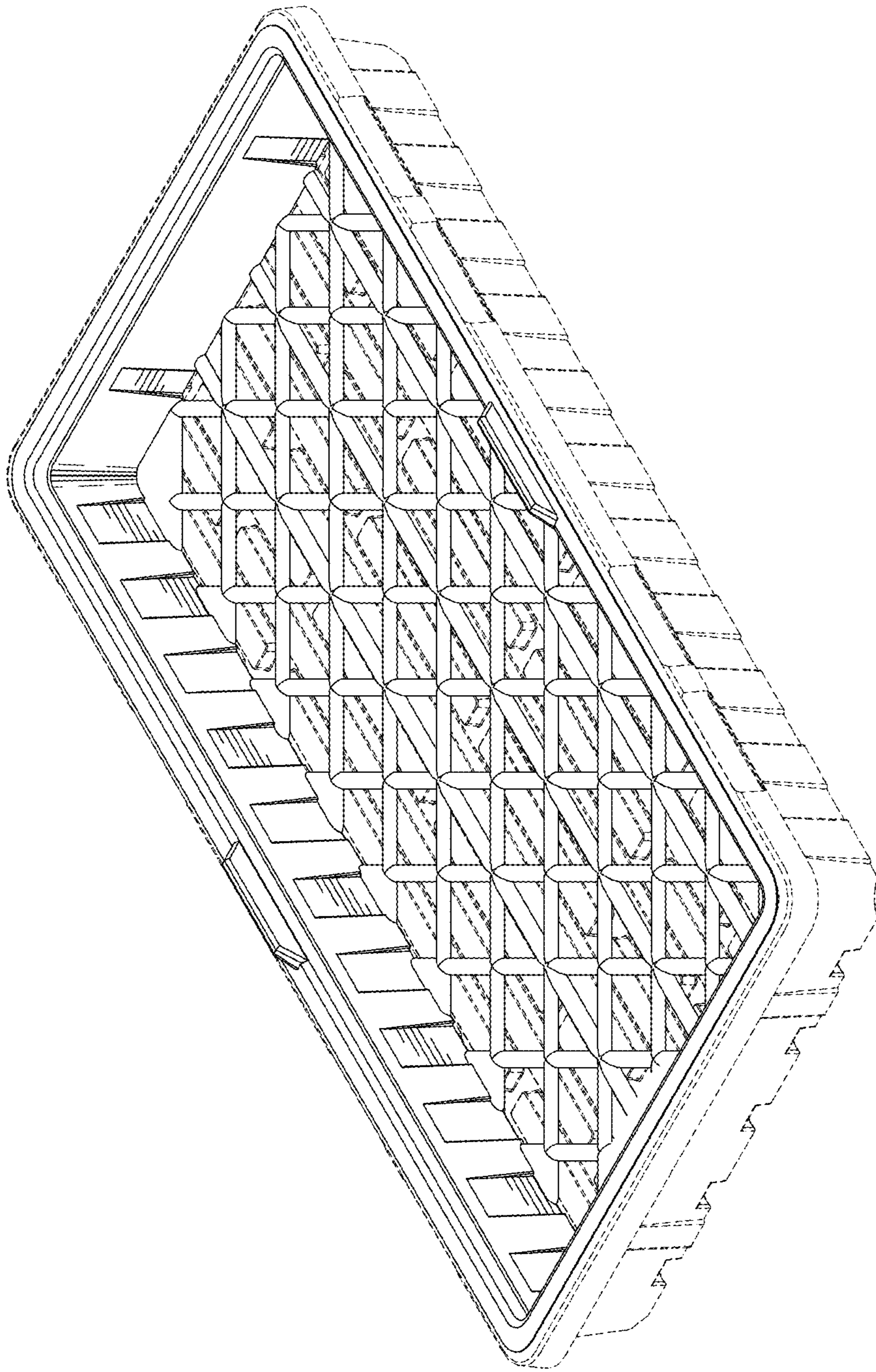

FIG. 17

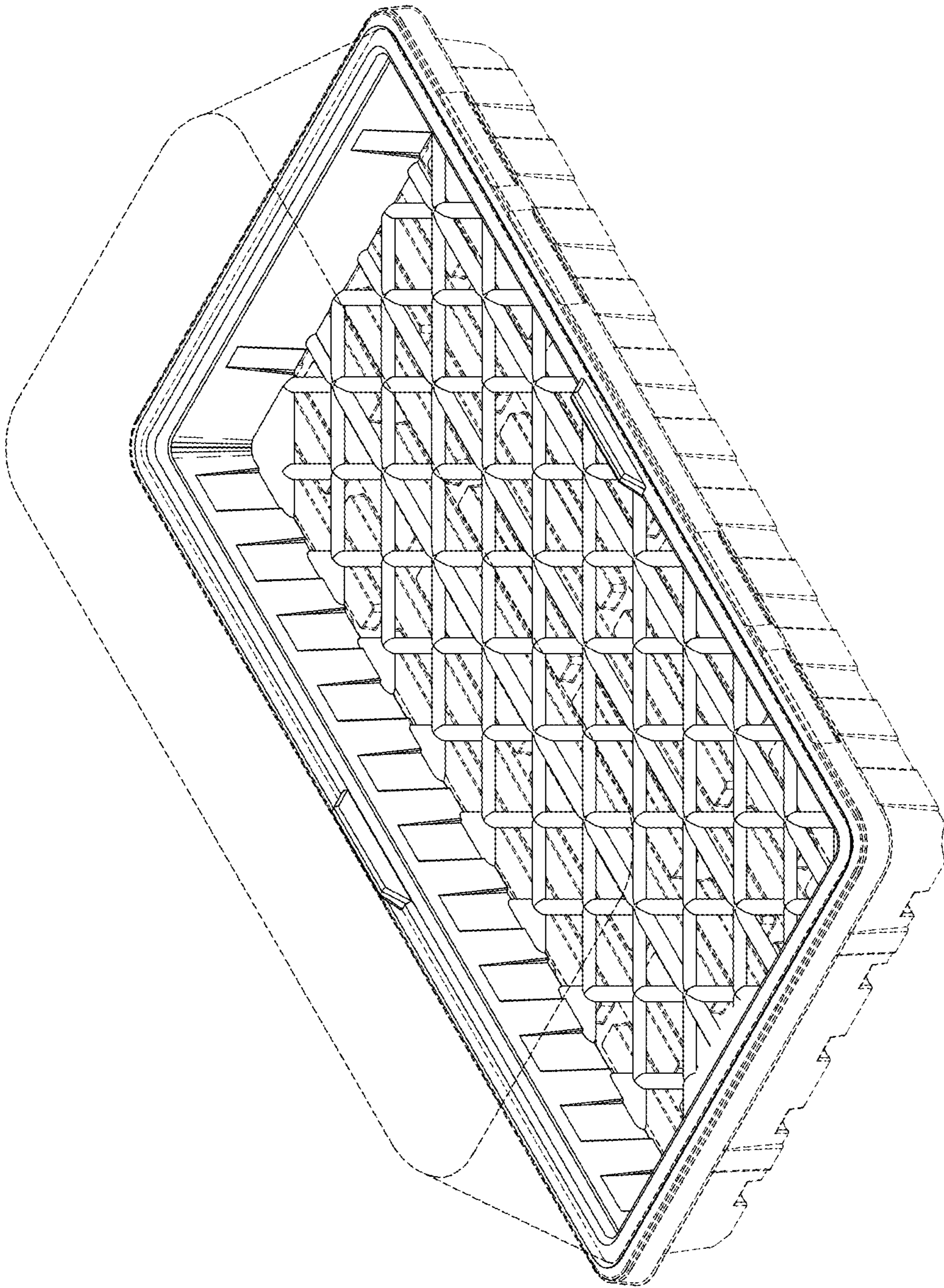

FIG. 14



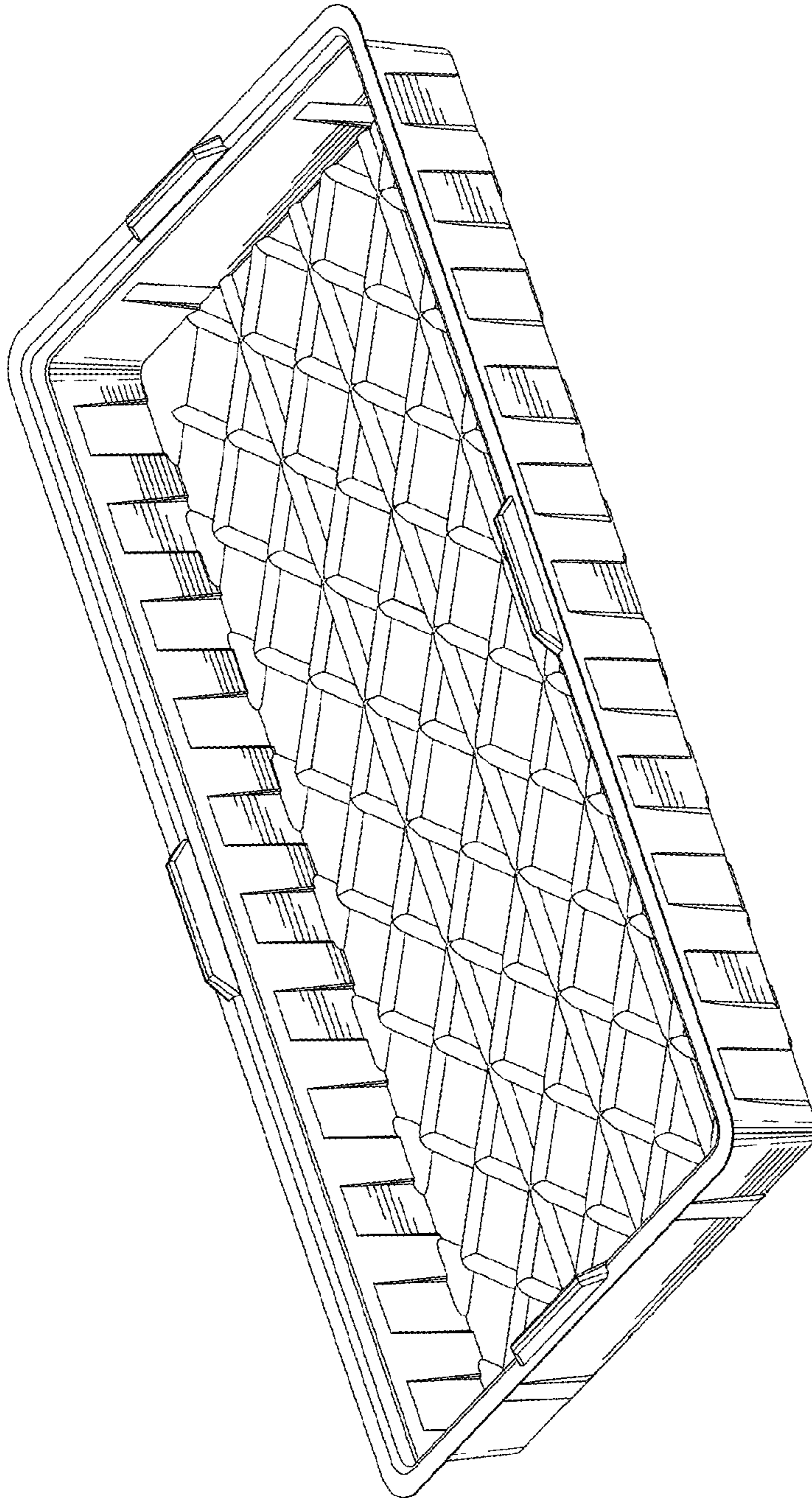

FIG. 19

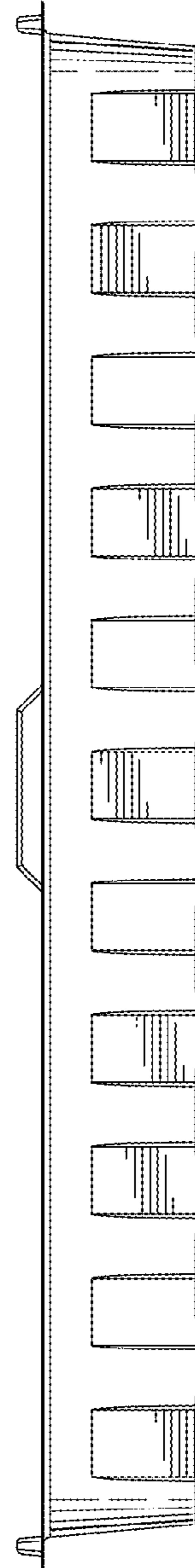

FIG. 20

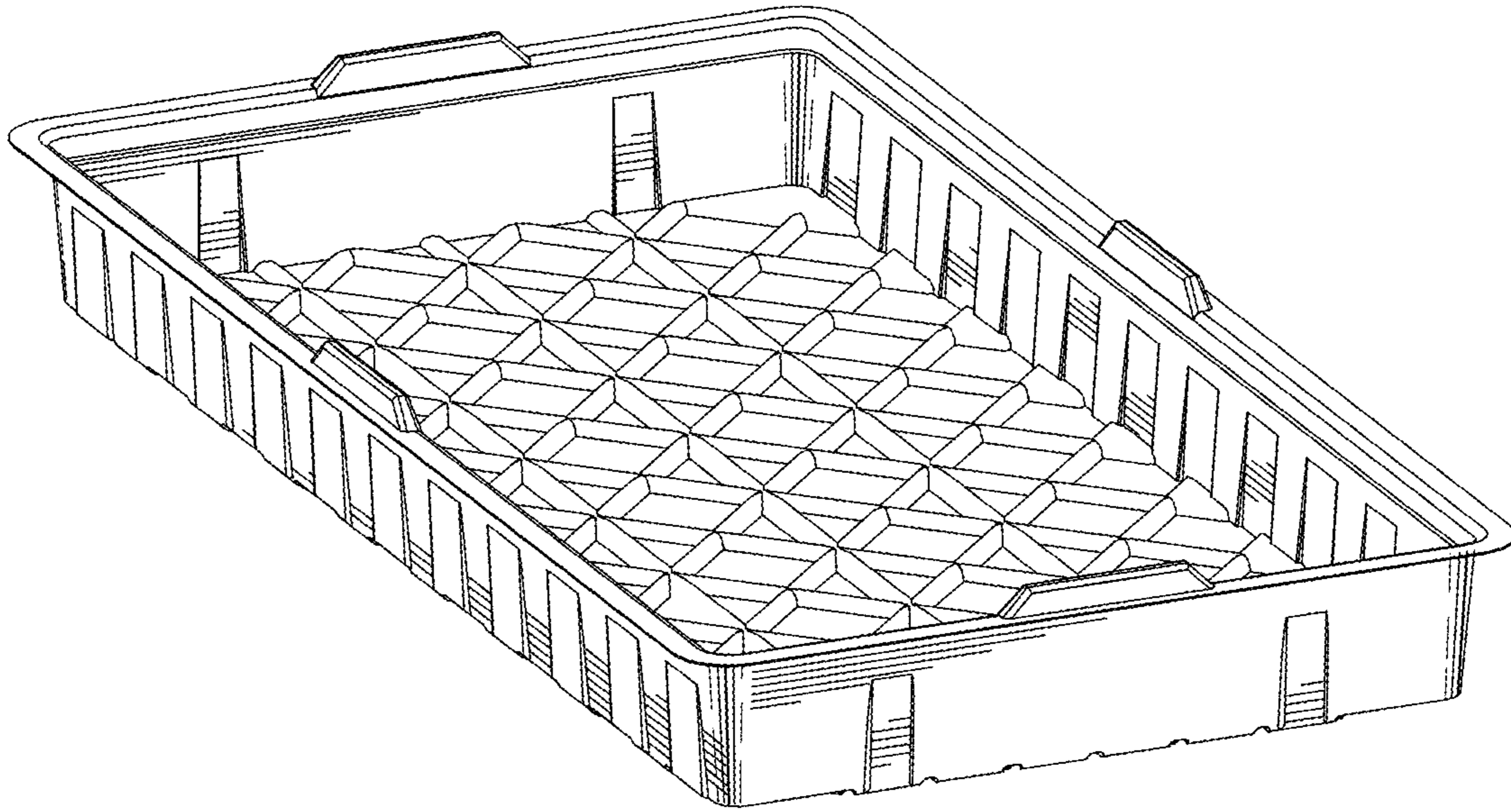

FIG. 21

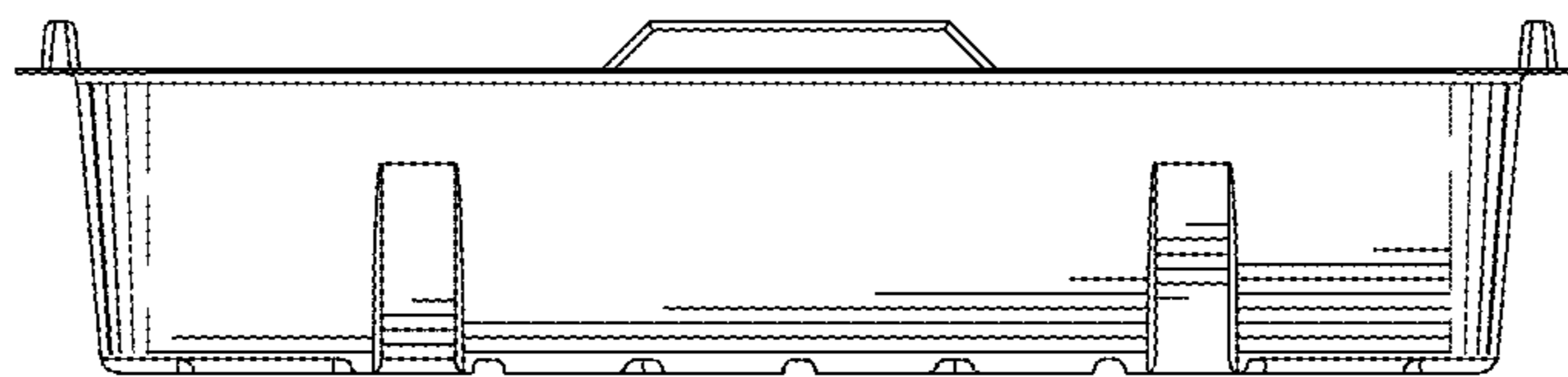

FIG. 22

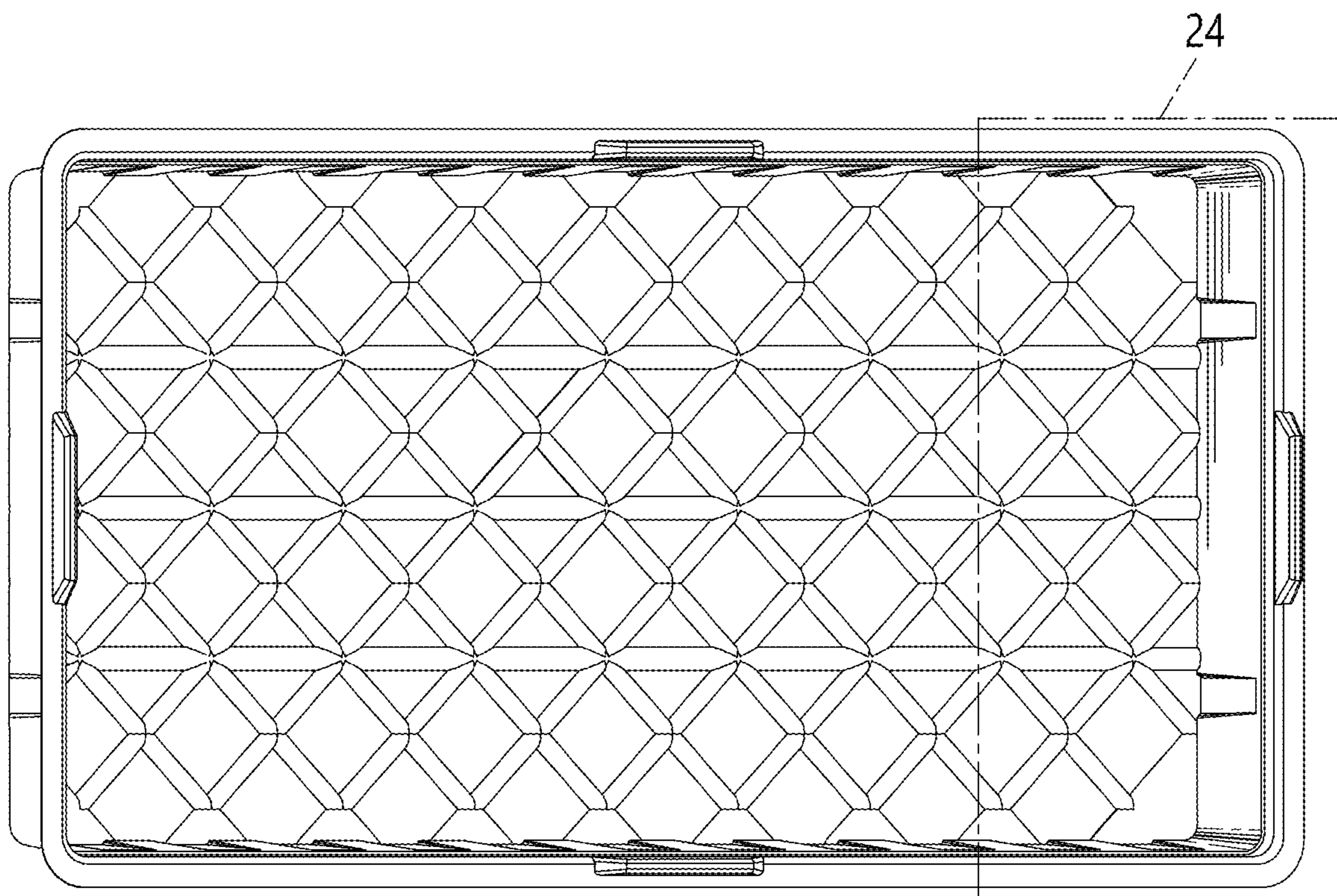

FIG. 23

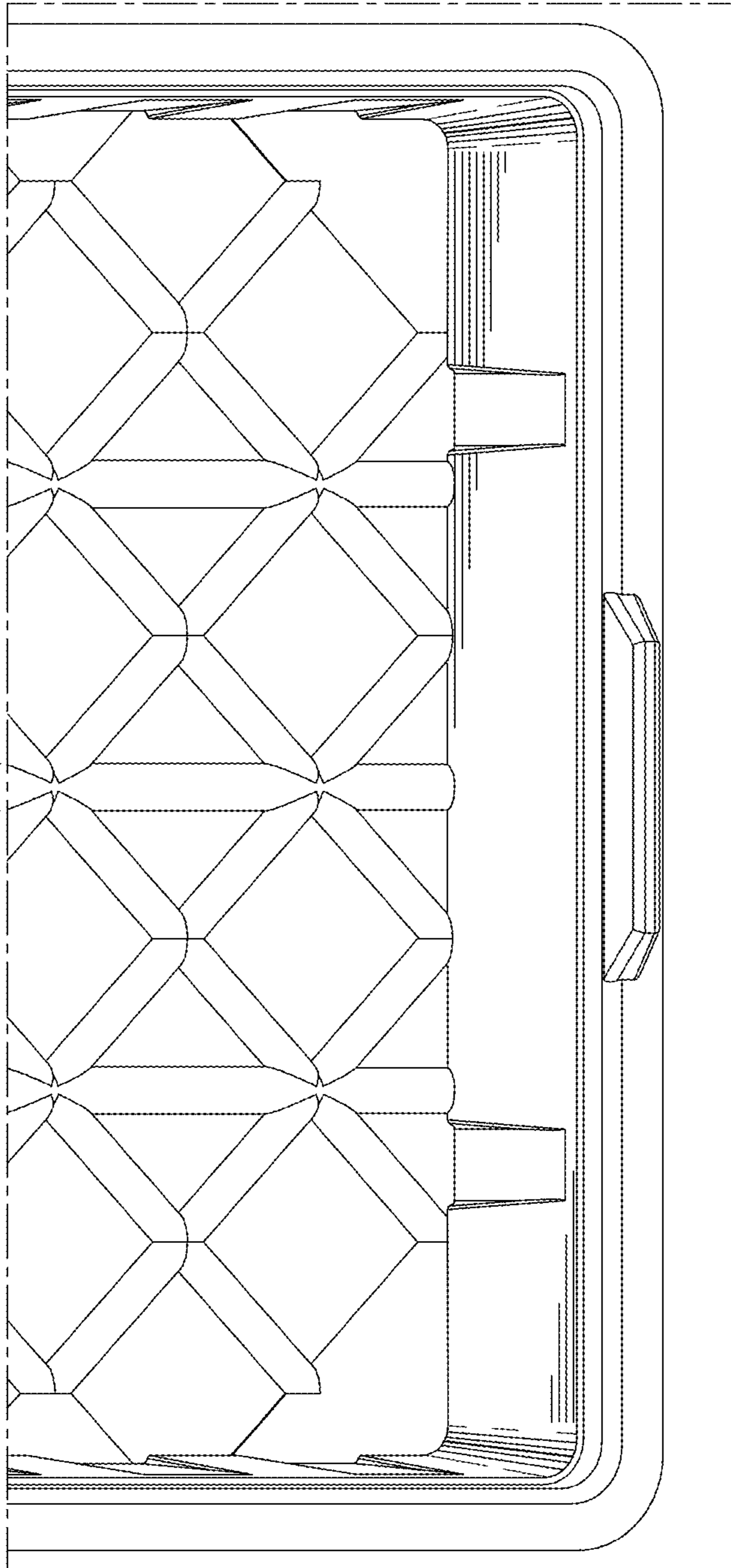

FIG. 24

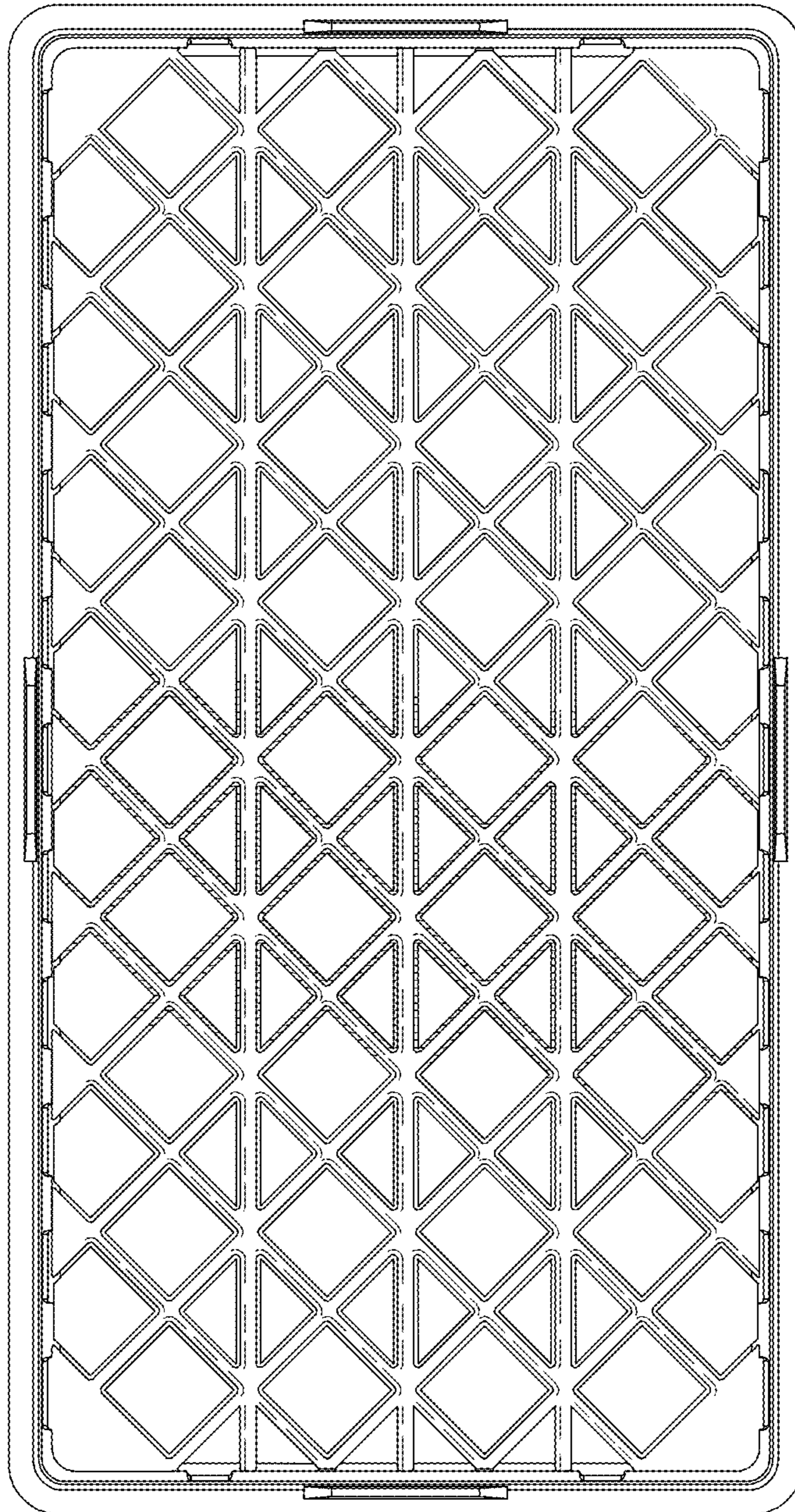

FIG. 25

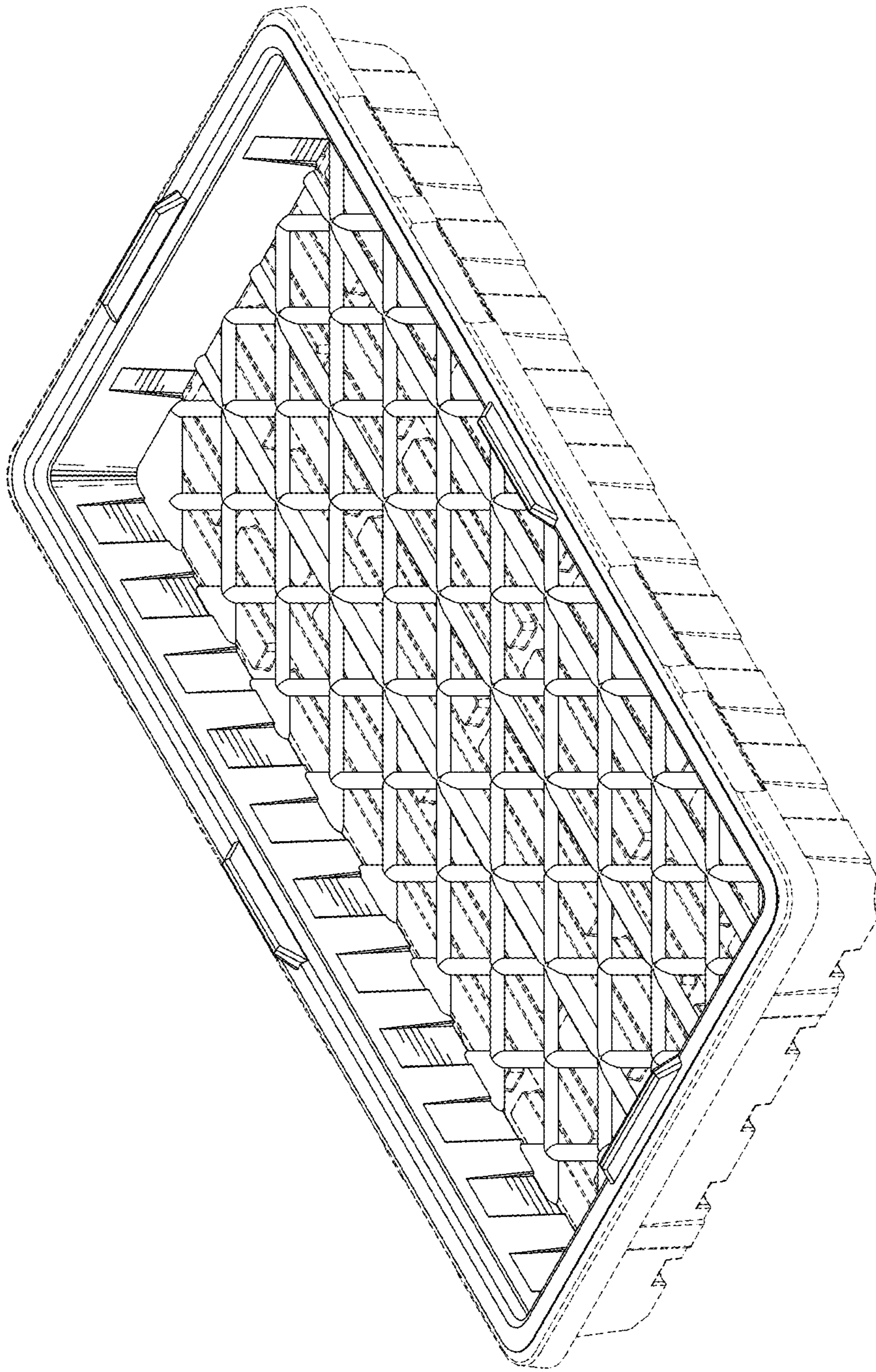

FIG. 20

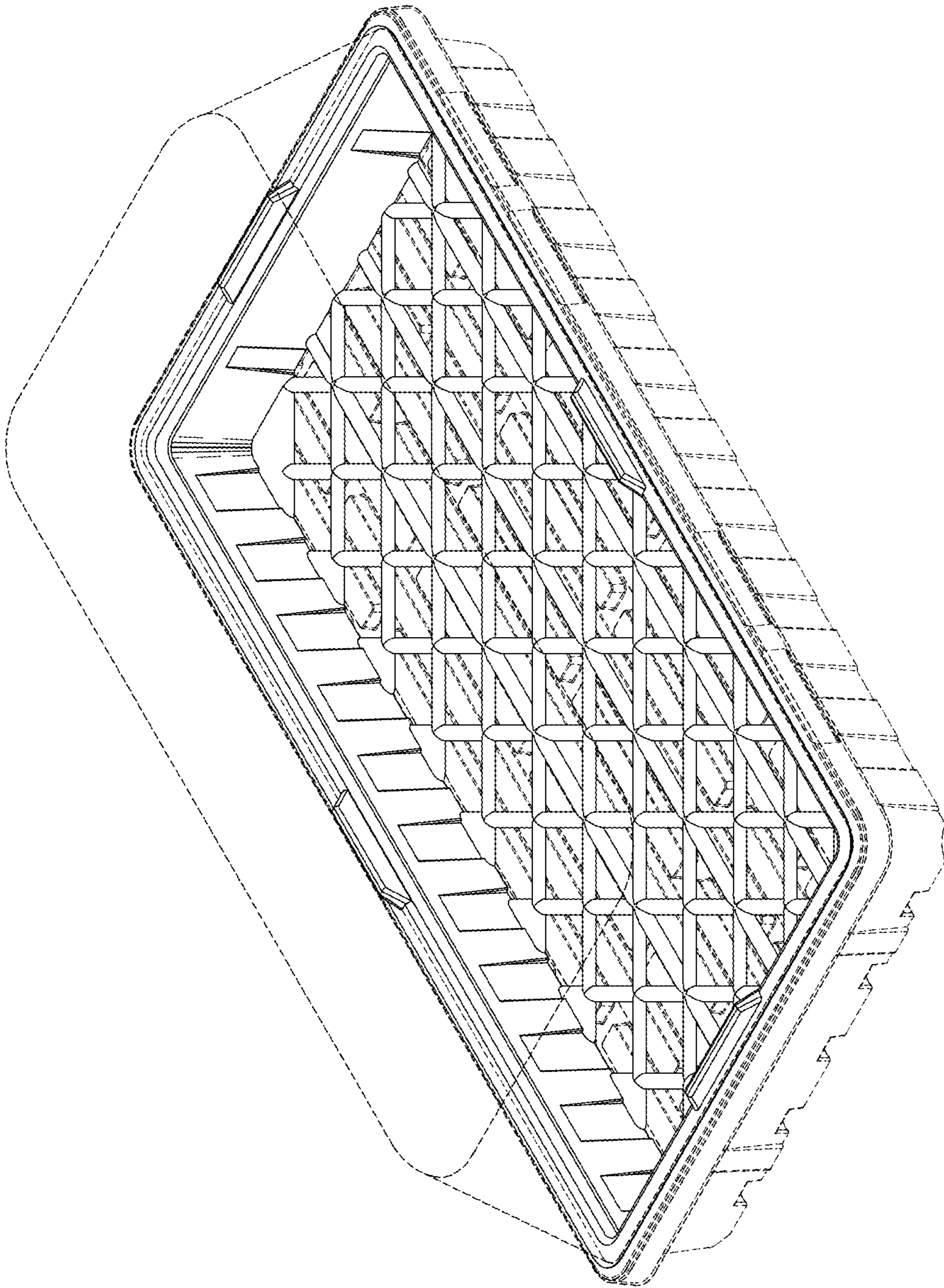

FIG. 27