



US00D942546S

(12) **United States Design Patent**
Ketter

(10) **Patent No.:** **US D942,546 S**

(45) **Date of Patent:** **** Feb. 1, 2022**

- (54) **REAL ESTATE SIGN POST**
- (71) Applicant: **4sygn LLC**, Glens Falls, NY (US)
- (72) Inventor: **Nicholas Ketter**, Glens Falls, NY (US)
- (73) Assignee: **4SYGN LLC**, Glens Falls, NY (US)

D285,220 S *	8/1986	Cooper	D20/42
4,790,092 A *	12/1988	Farmer	G09F 7/18 40/606.19
4,793,082 A *	12/1988	Petrick	G09F 7/22 40/606.18
4,843,746 A *	7/1989	DesNoyers	G09F 7/18 40/607.04

(Continued)

(**) Term: **15 Years**

(21) Appl. No.: **29/727,511**

(22) Filed: **Mar. 11, 2020**

(51) **LOC (13) Cl.** **20-02**

(52) **U.S. Cl.**
USPC **D20/41**

(58) **Field of Classification Search**
 USPC D6/658, 672, 674; D10/109.1, 109.2,
 D10/113.4; D11/181, 182, 183;
 D14/125, 126, 127, 128, 129, 489, 495;
 D18/26; D20/10, 11, 12, 16, 17, 18, 19,
 D20/21, 31, 27, 29, 30, 39, 40, 41, 42,
 D20/43, 44, 99; D26/93, 104, 137
 CPC G09F 1/00; G09F 1/08; G09F 5/00; G09F
 5/02; G09F 7/00; G09F 19/00; G09F
 23/00; G09F 27/00; G09F 21/00; G09F
 21/06; G09F 21/08; Y10S 362/812; A47F
 3/00; A47F 8/00; A47F 11/00
 See application file for complete search history.

(56) **References Cited**

U.S. PATENT DOCUMENTS

D166,998 S *	6/1952	Rasmussen	D6/672
2,926,442 A *	3/1960	Reimel	G09F 7/22 40/607.11
4,279,104 A *	7/1981	Classen	E01F 9/685 52/165
4,327,514 A *	5/1982	Bourque	G09F 7/18 40/606.19
D267,659 S *	1/1983	Samuels, Jr.	D20/42
4,483,506 A *	11/1984	Litwiller	E01F 9/685 248/156

OTHER PUBLICATIONS

4SYGN, posted at facebook.com, posted on Oct. 22, 2019, site visited Sep. 21, 2021. online, available from internet: <https://www.facebook.com/4sygn/photos/pcb.2426972160888840/2426972084222181/?type=3&theater> (Year: 2019).*

Primary Examiner — Mary Ann Calabrese
Assistant Examiner — Catherine Ho
 (74) *Attorney, Agent, or Firm* — Hoffman Warnick LLC

(57) **CLAIM**

I claim the ornamental design for a real estate sign post, as shown and described.

DESCRIPTION

FIG. 1 is a front perspective view of the first embodiment of a real estate sign post, showing my new design;
 FIG. 2 is front view of the real estate sign post of FIG. 1;
 FIG. 3 is a rear view of the real estate sign post of FIG. 1;
 FIG. 4 is a top view of the real estate sign post of FIG. 1;
 FIG. 5 is a first side view of the real estate sign post of FIG. 1;
 FIG. 6 is a second side view of the real estate sign post of FIG. 1; and,
 FIG. 7 is a front view of the second embodiment of the real estate sign post of FIG. 1.
 The broken line portion of the drawings show environment and form no part of the claimed design. FIG. 7 shows a portion of the article in broken line and forms no part of the claimed design.

1 Claim, 6 Drawing Sheets

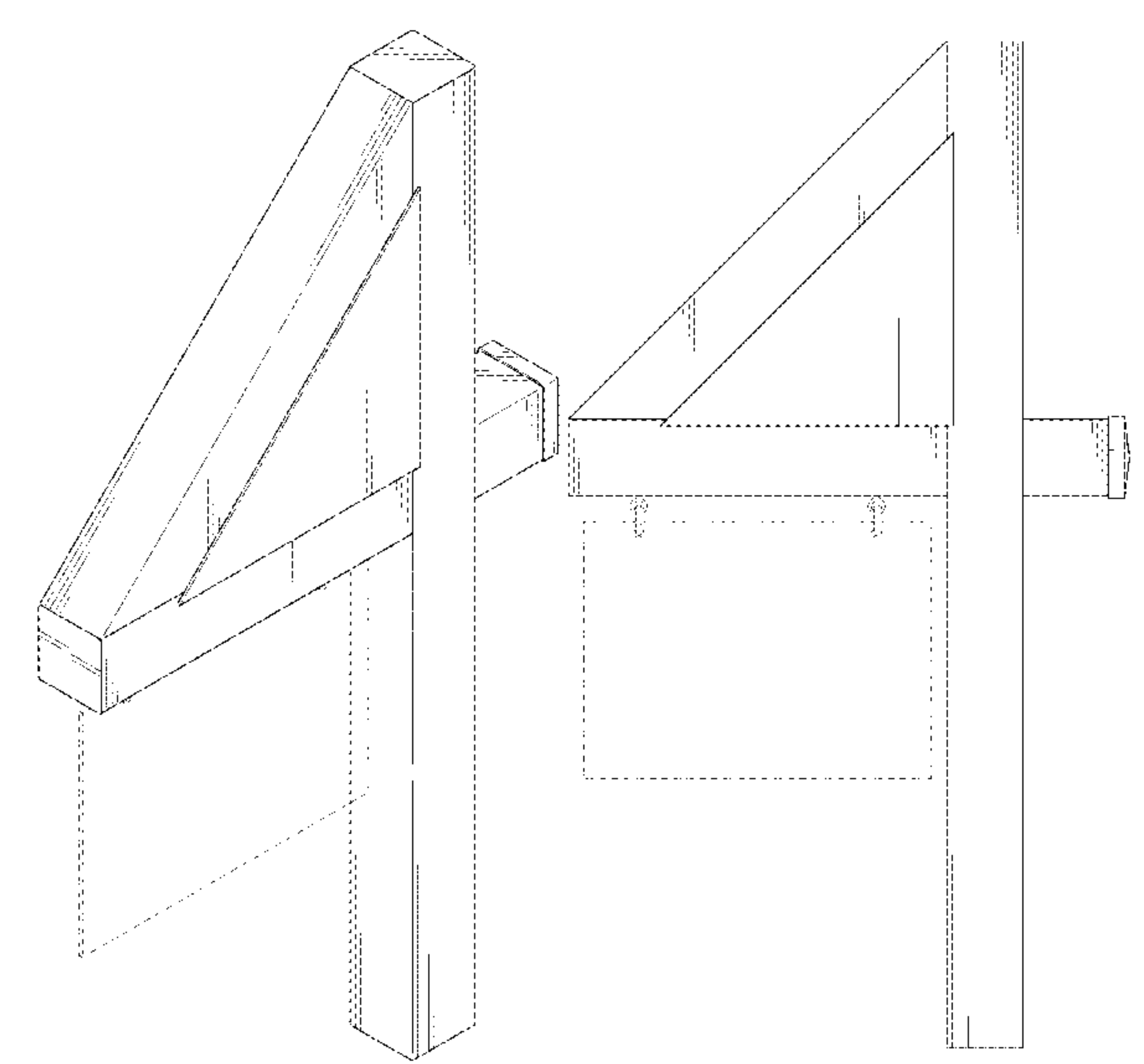

(56)

References Cited

U.S. PATENT DOCUMENTS

5,833,181 A * 11/1998 DesNoyers E01F 9/685
 248/156
 D410,253 S * 5/1999 Gagnon D20/41
 5,903,991 A * 5/1999 Sasse G09F 7/22
 40/607.04
 6,003,255 A * 12/1999 Mahoney G09F 7/22
 40/611.02
 6,575,423 B2 * 6/2003 Erwin A47G 29/1216
 248/121
 D639,479 S * 6/2011 Cortes D26/67
 D641,793 S * 7/2011 Dumontier D20/41
 D652,876 S * 1/2012 Lotzof D20/41
 8,313,210 B2 * 11/2012 Zheng F21S 9/037
 362/183
 8,459,826 B2 * 6/2013 Holman G09F 13/02
 362/183
 9,262,948 B2 * 2/2016 Pounders G09F 13/02
 9,542,871 B1 * 1/2017 White G09F 15/0056
 D785,097 S * 4/2017 Fiore D20/41
 9,741,269 B2 * 8/2017 Ellingson E04H 17/1447
 2007/0193088 A1 * 8/2007 Lemberger G09F 13/22
 40/544
 2020/0111392 A1 * 4/2020 Wagnermarsh G06Q 30/0261

* cited by examiner

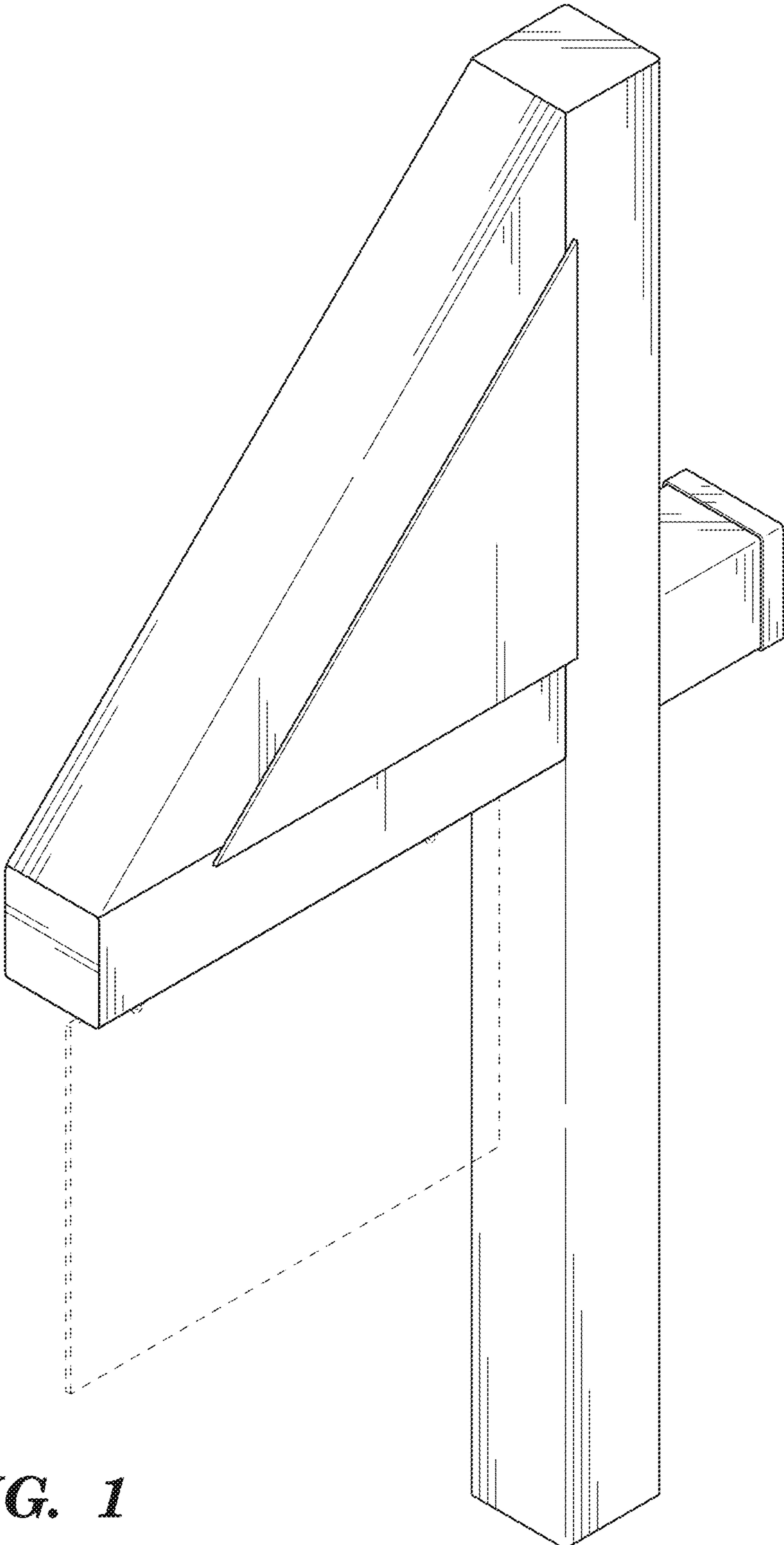

FIG. 1

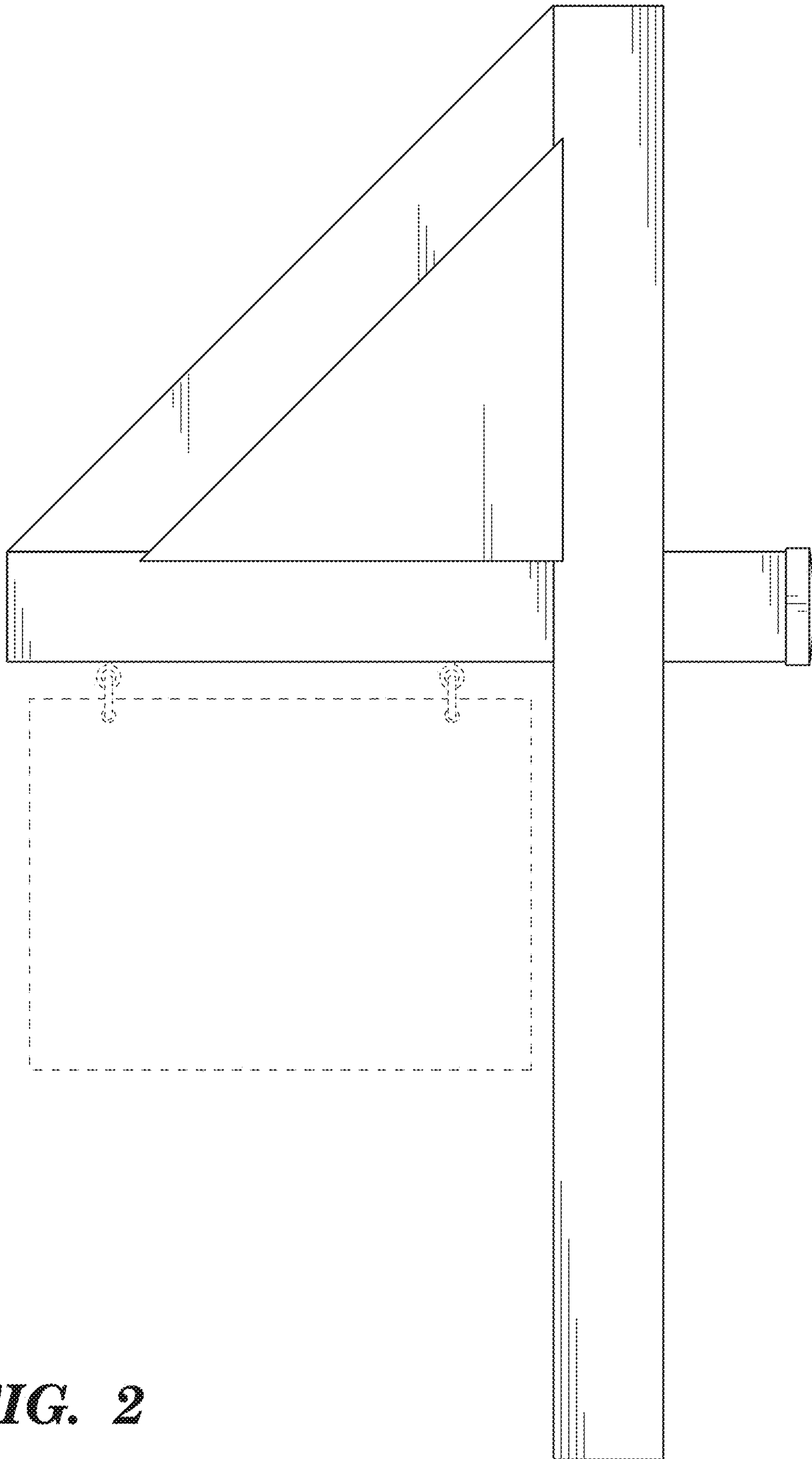

FIG. 2

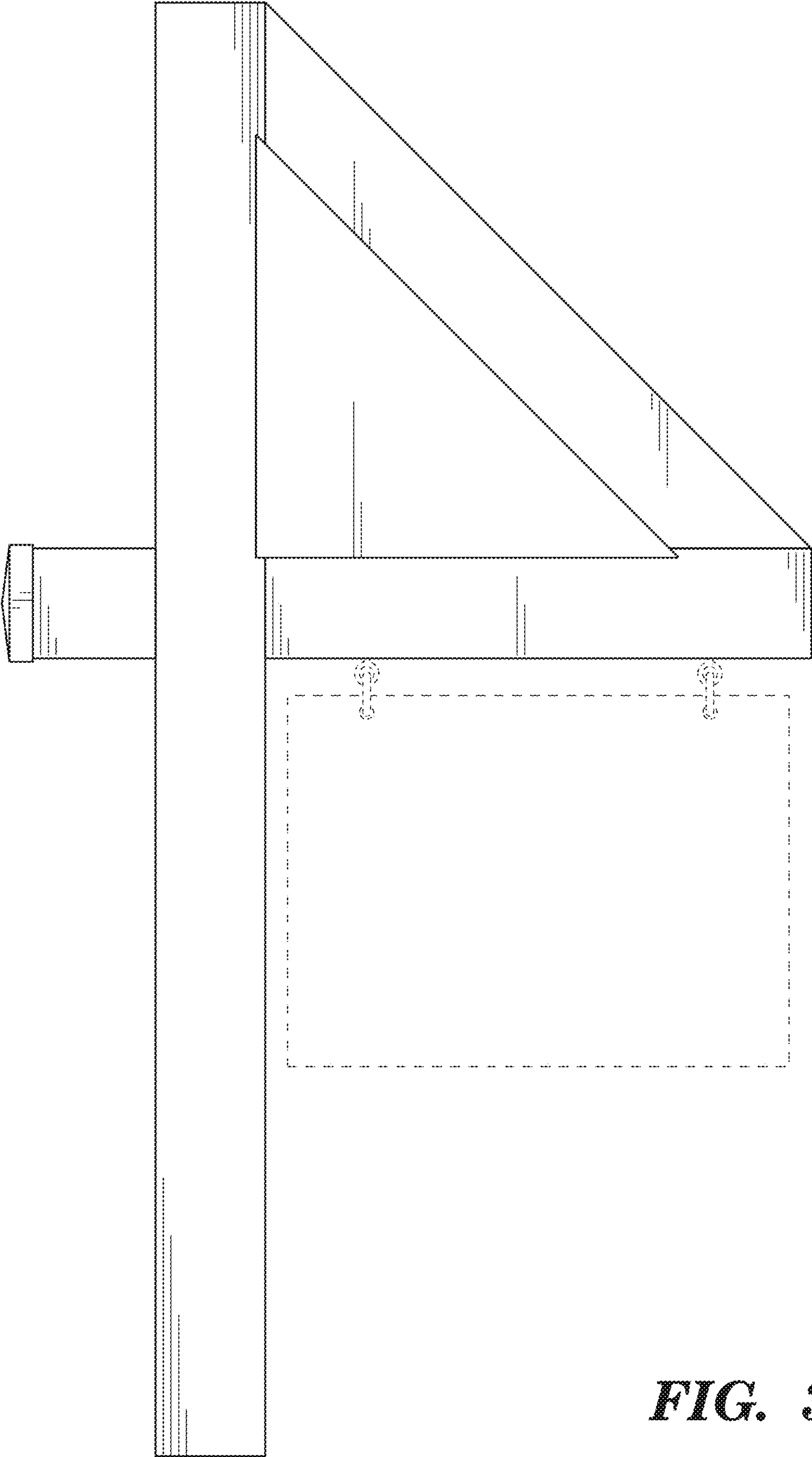

FIG. 3

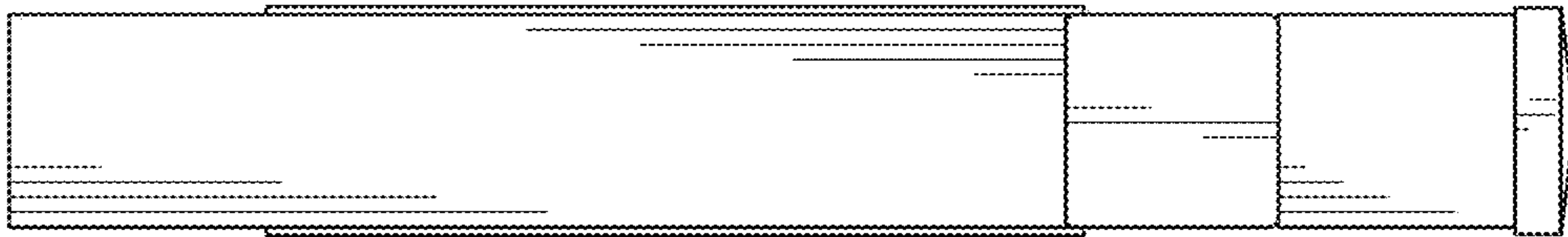

FIG. 4

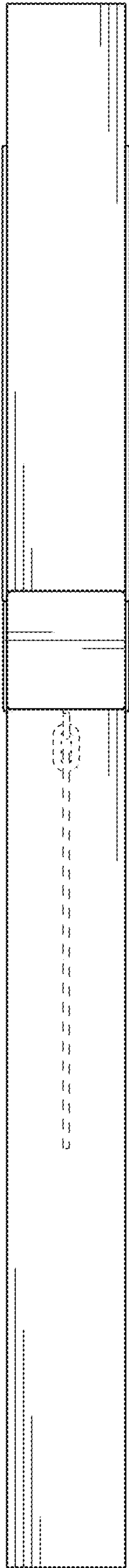

FIG. 5

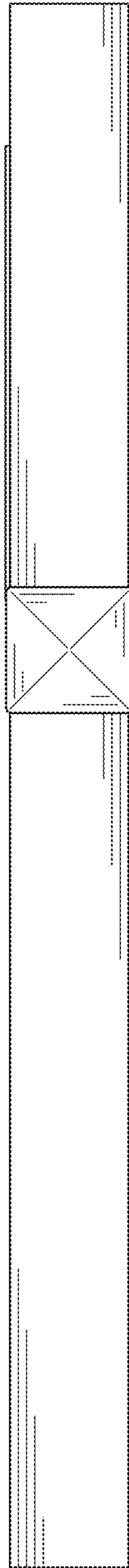

FIG. 6

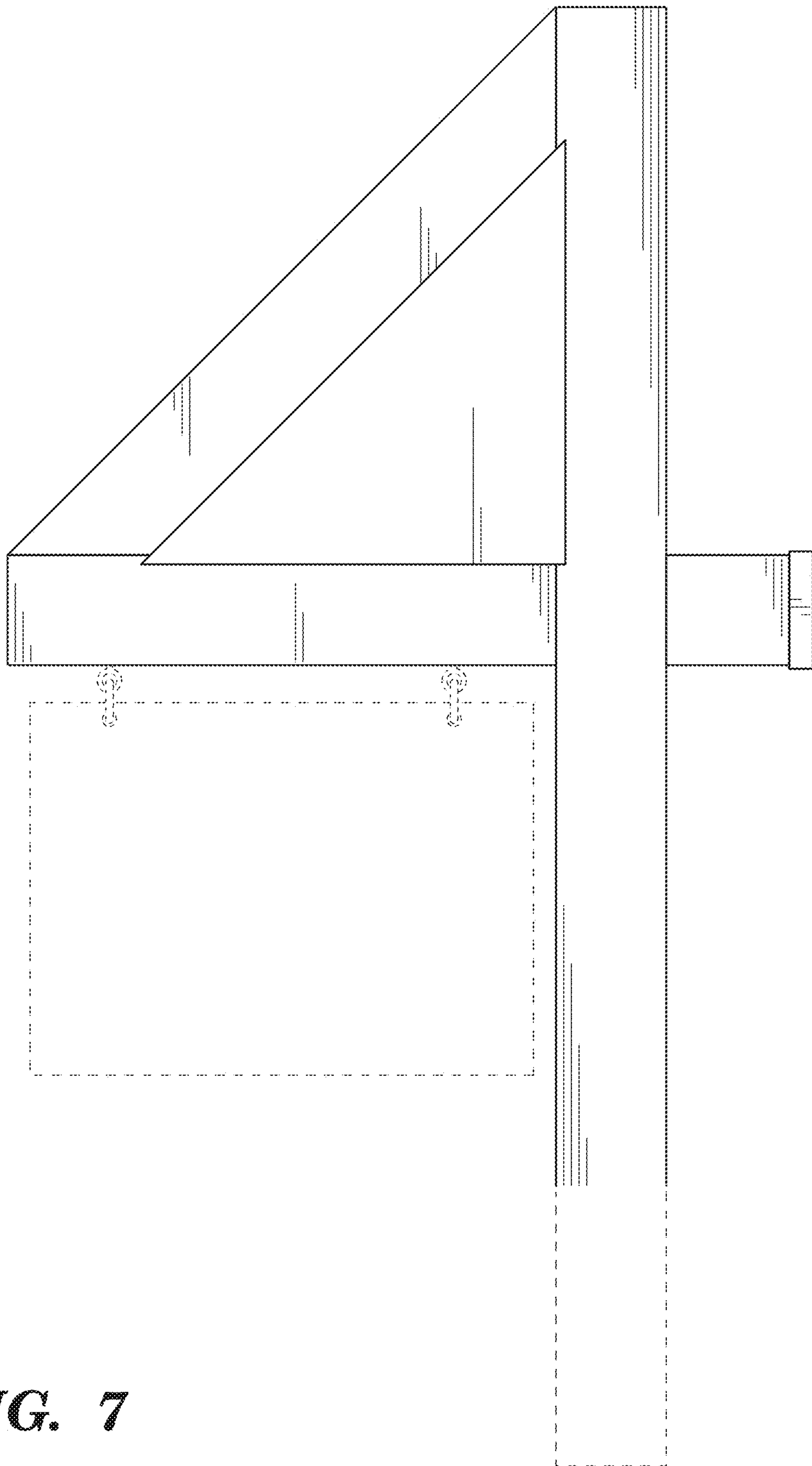

FIG. 7