



US00D942336S

(12) **United States Design Patent**
Gunnarson

(10) **Patent No.:** **US D942,336 S**

(45) **Date of Patent:** **** Feb. 1, 2022**

(54) **GRILLE FOR A VEHICLE**

D809,978 S * 2/2018 Myrberg D12/163
D814,367 S * 4/2018 Myrberg D12/163
D876,280 S * 2/2020 Mayer D12/92

(71) Applicant: **VOLVO CAR CORPORATION**,
Gothenburg (SE)

(72) Inventor: **Anders Gunnarson**, Kullavik (SE)

(73) Assignee: **VOLVO CAR CORPORATION**,
Gothenburg (SE)

(**) Term: **15 Years**

(21) Appl. No.: **29/760,598**

(22) Filed: **Dec. 2, 2020**

(30) **Foreign Application Priority Data**

Jul. 9, 2020 (WO) WIPO95984

(51) **LOC (13) Cl.** **12-16**

(52) **U.S. Cl.**
USPC **D12/163**

(58) **Field of Classification Search**

USPC D12/163, 169, 196, 86, 90-92; 180/68.1,
180/68.6; 293/193.11

CPC B62D 25/08; B62B 9/16; B60K 11/08;
B60R 19/52

See application file for complete search history.

(56) **References Cited**

U.S. PATENT DOCUMENTS

D729,705 S * 5/2015 Gunnarson D12/163
D775,555 S * 1/2017 Myrberg D12/163

OTHER PUBLICATIONS

NetCarShow.com, Volvo, Design Name: Concept Coupe, Year of Introduction: 2019.

NetCarShow.com, Volvo, Design Name: V60, Year of Introduction: 2013.

NetCarShow.com, Volvo, Design Name: XC90, Year of Introduction: 2014.

* cited by examiner

Primary Examiner — Melody N Brown

(74) *Attorney, Agent, or Firm* — Berenato & White, LLC

(57) **CLAIM**

The ornamental design for a grille for a vehicle, as shown and described.

DESCRIPTION

FIG. 1 is a front view of a grille showing my new design; FIG. 2 is a left, front perspective view thereof; FIG. 3 is a right, front perspective view thereof; FIG. 4 is a right side view thereof; FIG. 5 is a left side view thereof; FIG. 6 is a top view thereof; FIG. 7 is a bottom view thereof; and, FIG. 8 is a rear view thereof.

1 Claim, 8 Drawing Sheets



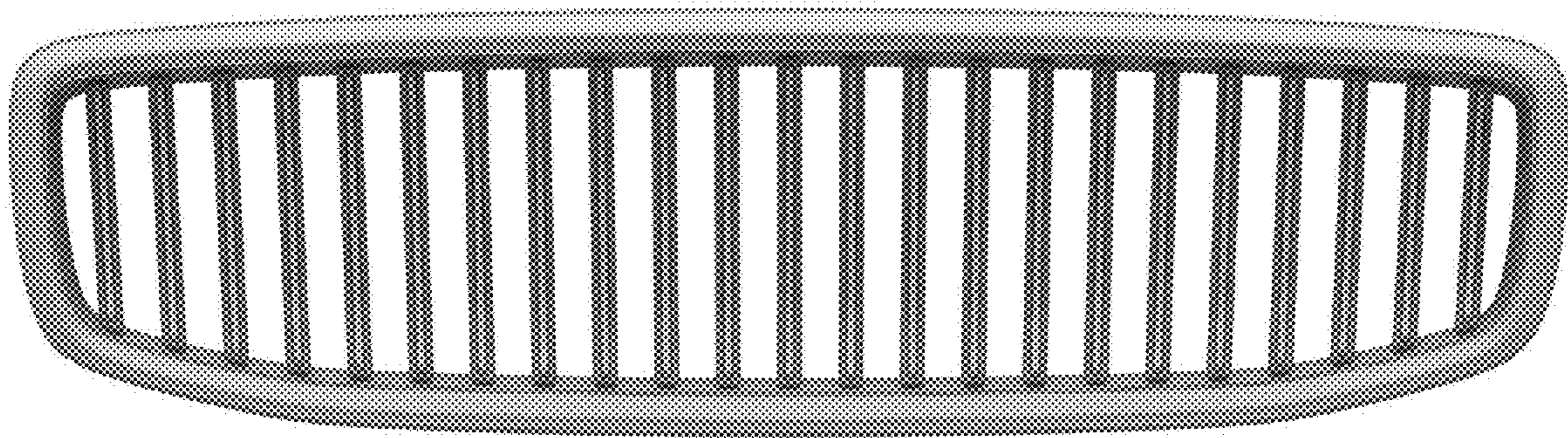

FIG. 1

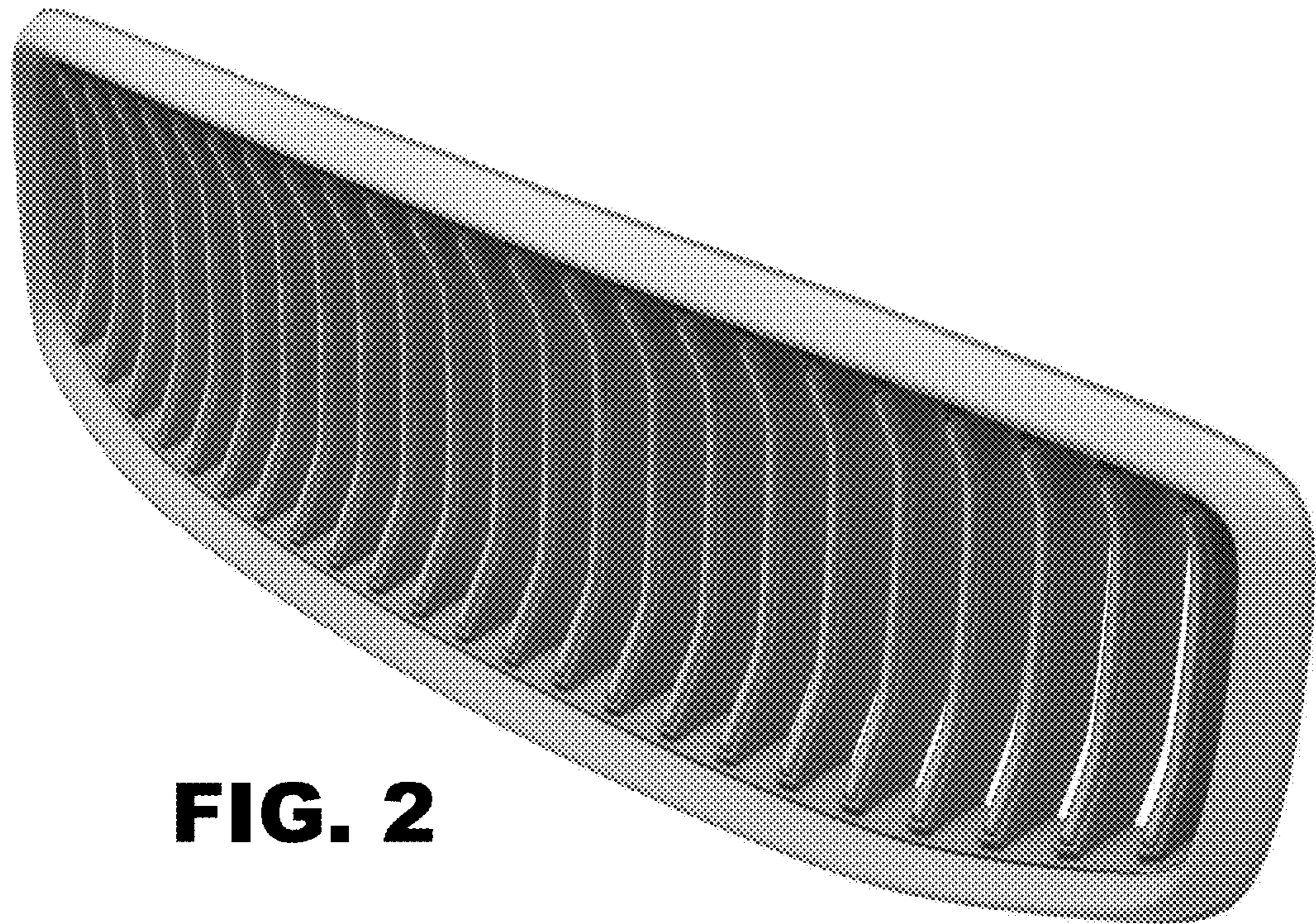

FIG. 2

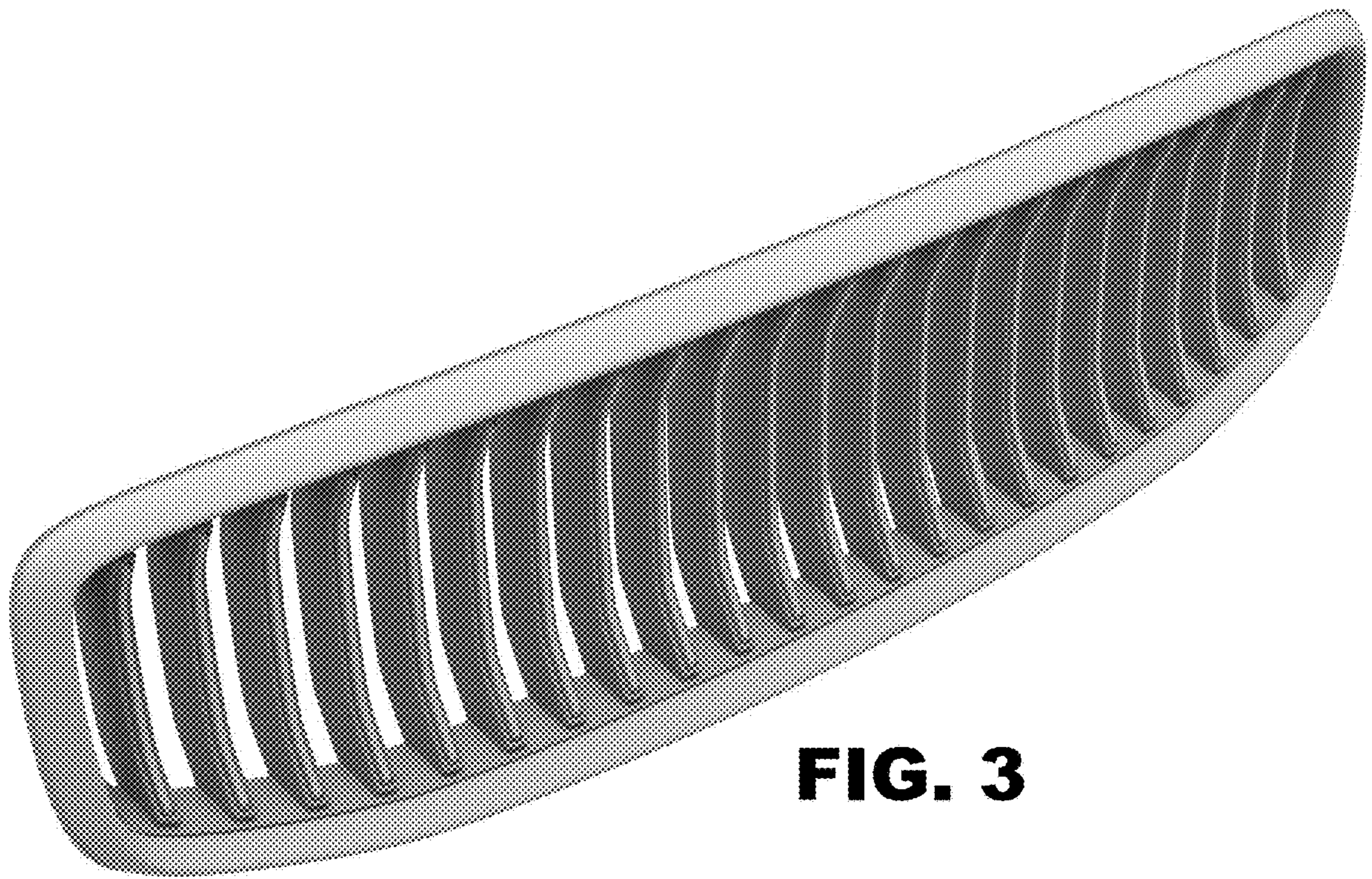

FIG. 3

FIG. 4

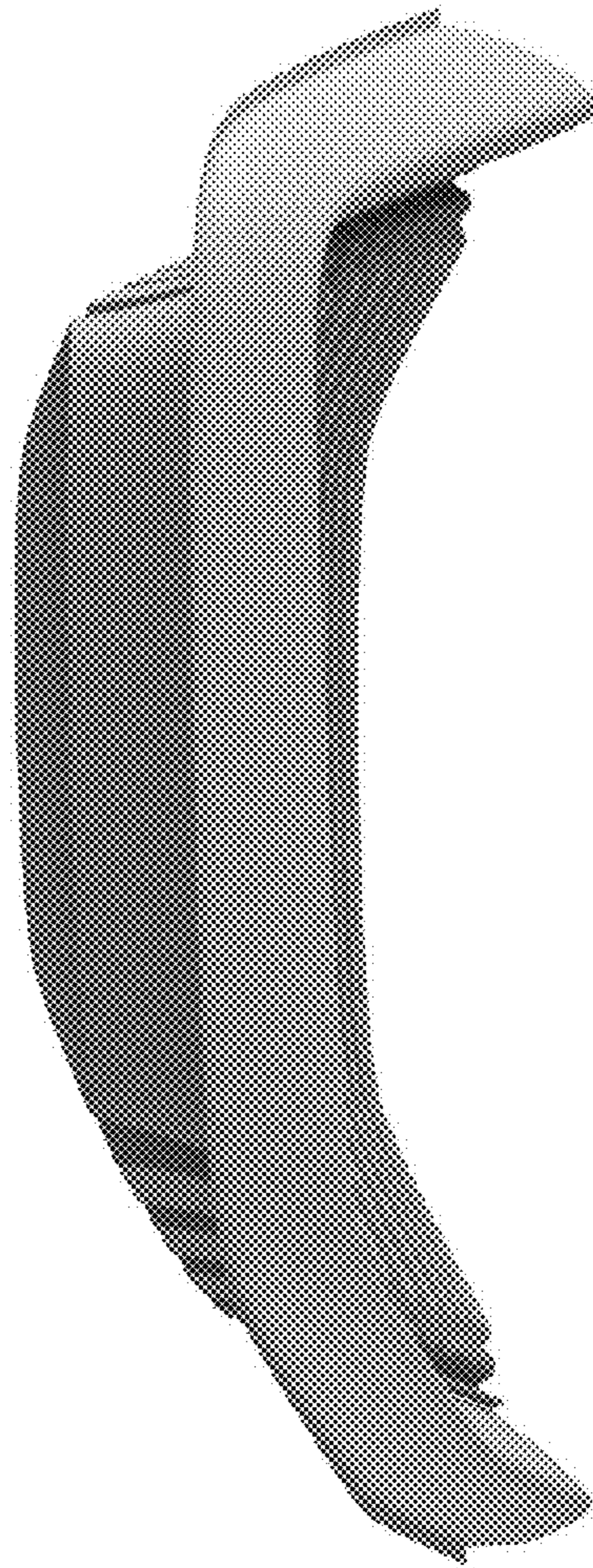

FIG. 5

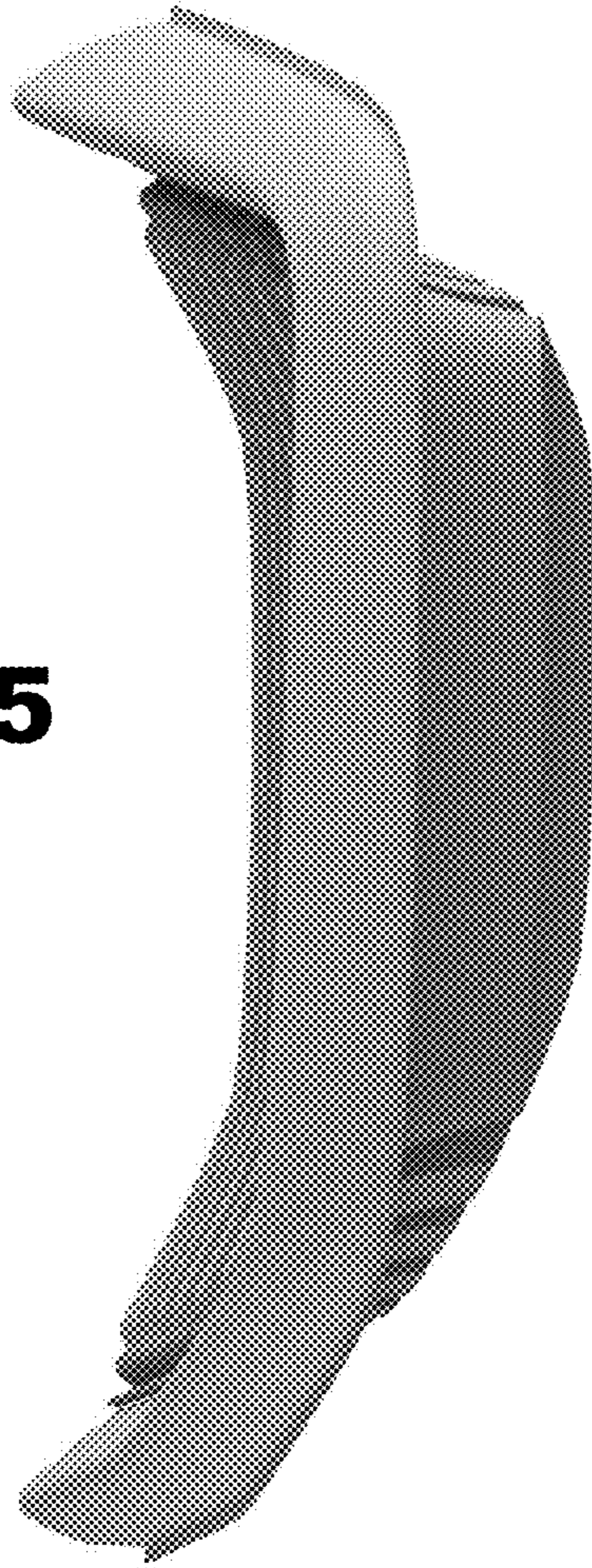

FIG. 6

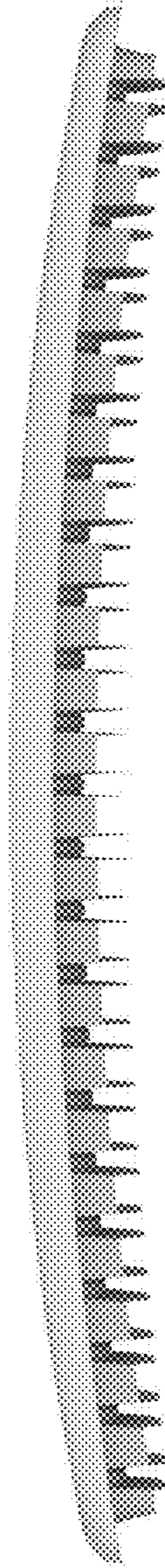
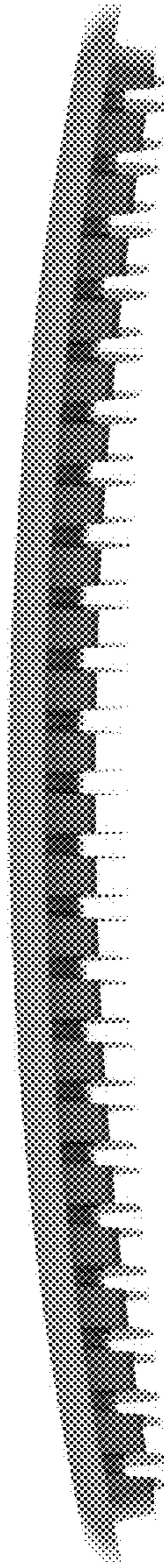

FIG. 7



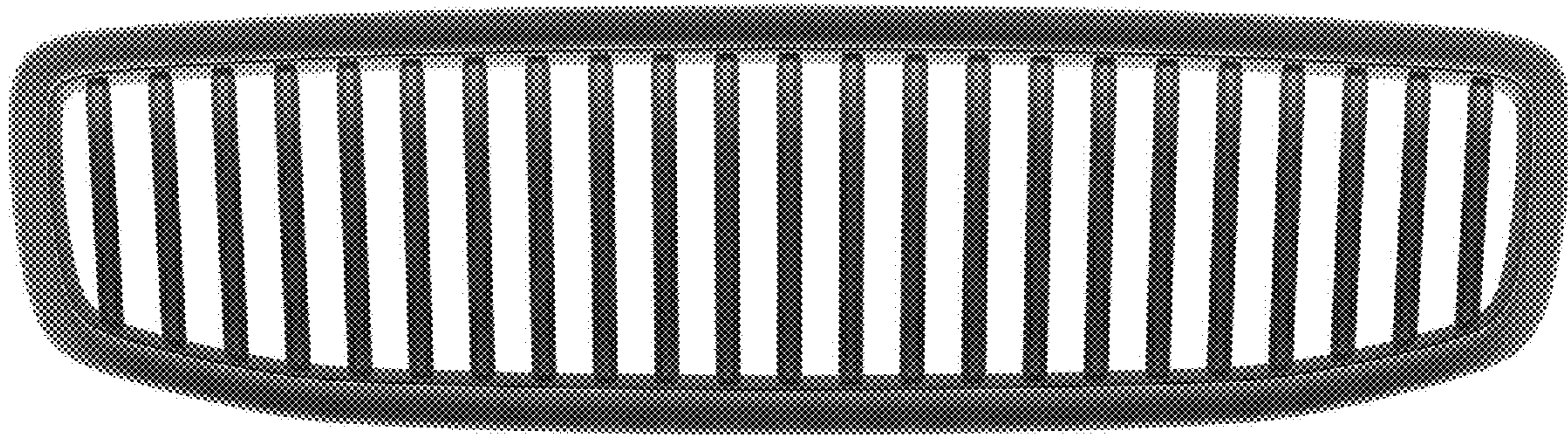

FIG. 8