



US00D941961S

(12) **United States Design Patent**  
**Abel**

(10) **Patent No.:** **US D941,961 S**

(45) **Date of Patent:** **\*\* Jan. 25, 2022**

(54) **FAUCET**

(71) Applicant: **Watermark Designs, LLC**, Brooklyn, NY (US)

(72) Inventor: **Avi Abel**, Brooklyn, NY (US)

(73) Assignee: **WATERMARK DESIGNS, LLC**, Brooklyn, NY (US)

(\*\*) Term: **15 Years**

(21) Appl. No.: **29/720,082**

(22) Filed: **Jan. 9, 2020**

(51) **LOC (13) Cl.** ..... **23-01**

(52) **U.S. Cl.**  
USPC ..... **D23/242**

(58) **Field of Classification Search**  
USPC ..... D23/238-244, 252, 254-255, 257;  
D8/307-308  
CPC .... F16K 31/602; F16K 31/605; F16K 31/607;  
E03C 1/0412

See application file for complete search history.

(56) **References Cited**

**U.S. PATENT DOCUMENTS**

|              |         |          |       |         |
|--------------|---------|----------|-------|---------|
| D469,507 S * | 1/2003  | Marshall | ..... | D23/242 |
| D469,508 S * | 1/2003  | Marshall | ..... | D23/242 |
| D469,509 S * | 1/2003  | Marshall | ..... | D23/242 |
| D469,510 S * | 1/2003  | Marshall | ..... | D23/242 |
| D479,740 S * | 9/2003  | Citterio | ..... | D23/242 |
| D624,991 S * | 10/2010 | Kulig    | ..... | D23/242 |
| D655,786 S * | 3/2012  | Fukasawa | ..... | D23/242 |
| D667,935 S * | 9/2012  | Liao     | ..... | D23/242 |
| D680,626 S * | 4/2013  | Kwok     | ..... | D23/242 |
| D712,515 S * | 9/2014  | Citterio | ..... | D23/242 |
| D734,837 S * | 7/2015  | Sieger   | ..... | D23/242 |
| D809,105 S * | 1/2018  | Cheng    | ..... | D23/242 |
| D823,439 S * | 7/2018  | Sieger   | ..... | D23/242 |
| D848,574 S * | 5/2019  | Garland  | ..... | D23/242 |
| D856,487 S * | 8/2019  | Spangler | ..... | D23/242 |

|              |         |         |       |         |
|--------------|---------|---------|-------|---------|
| D859,592 S * | 9/2019  | Seum    | ..... | D23/242 |
| D862,655 S * | 10/2019 | Garland | ..... | D23/242 |
| D865,125 S * | 10/2019 | Zeng    | ..... | D23/242 |
| D867,543 S * | 11/2019 | Garland | ..... | D23/242 |
| D869,613 S * | 12/2019 | Garland | ..... | D23/242 |
| D883,443 S * | 5/2020  | Kuang   | ..... | D23/242 |

(Continued)

**FOREIGN PATENT DOCUMENTS**

WO D071276-001 \* 1/2009

**OTHER PUBLICATIONS**

Watermark 70-8-RNS4 Deck Mounted 3 Hold Bath Set, specification sheet in pdf format, Sep. 11, 2019, [retrieved Mar. 25, 2021]. Retrieved from internet, <https://watermark-designs.com/product/70-8>.\*

(Continued)

*Primary Examiner* — Barbara Fox

*Assistant Examiner* — Jamaal Rasheed

(74) *Attorney, Agent, or Firm* — Schultz & Associates, P.C.

(57) **CLAIM**

The ornamental design for a faucet, as shown and described.

**DESCRIPTION**

FIG. 1 is a front perspective view of a faucet, showing my new design;  
FIG. 2 is a front elevation view thereof;  
FIG. 3 is a rear elevation view thereof;  
FIG. 4 is a right side elevation view thereof;  
FIG. 5 is a left side elevation view thereof;  
FIG. 6 is a top plan view thereof; and,  
FIG. 7 is a bottom plan view thereof.  
The broken lines shown in the figures depict portions of the faucet that form no part of the claimed design.

**1 Claim, 6 Drawing Sheets**

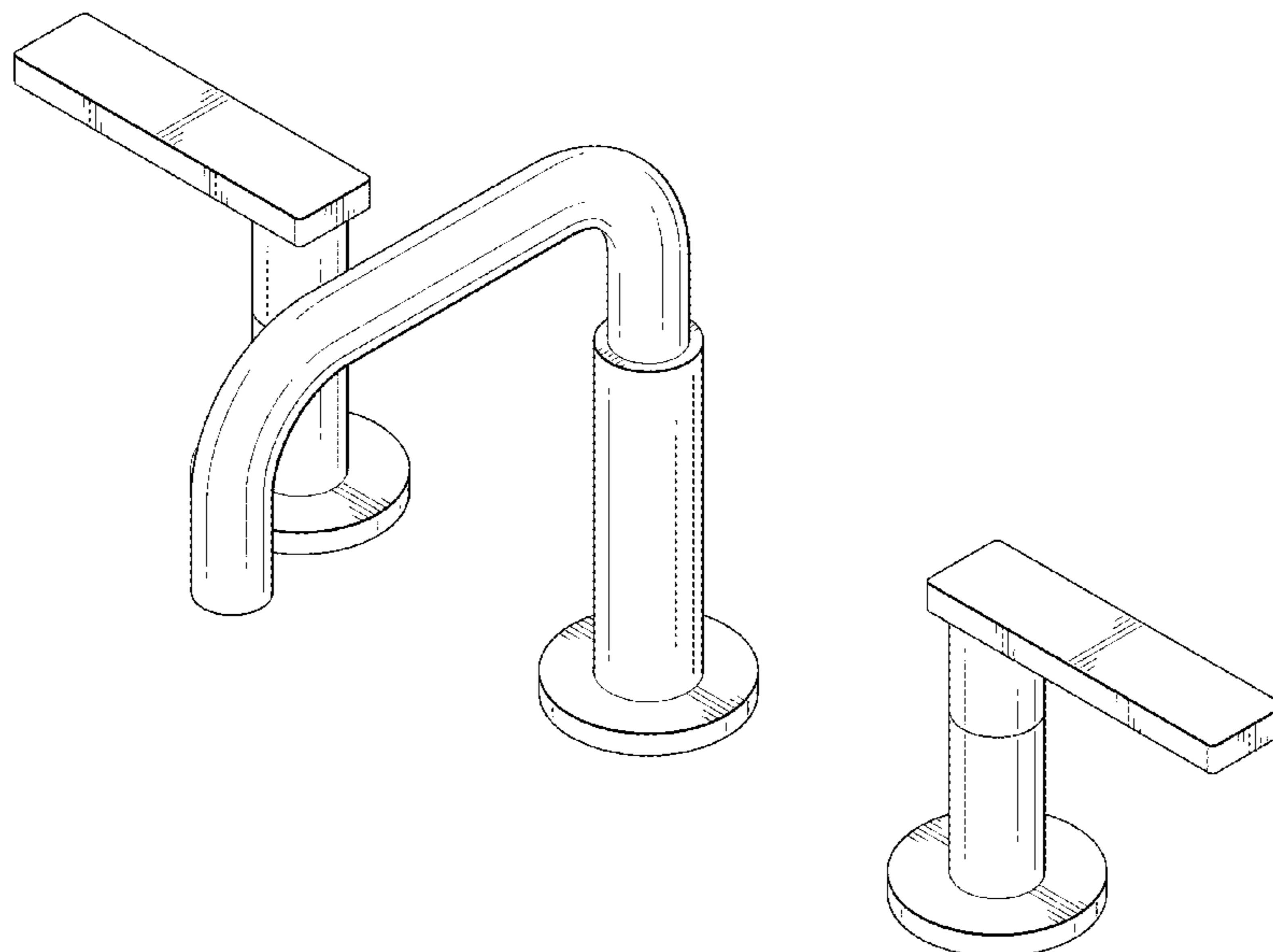

(56)

**References Cited**

U.S. PATENT DOCUMENTS

D890,306 S \* 7/2020 Potter ..... D23/242  
2014/0048145 A1 \* 2/2014 Chong ..... E03C 1/0404  
137/15.01

OTHER PUBLICATIONS

TimeArrow TAF830E-PB 2 Handle 8 inch Widespread Bathroom Sink Faucet, Date First Available Aug. 1, 2019[online], [site visited Mar. 19, 2021]. Available from internet, URL:<<https://www.amazon.com/TimeArrow-TAF830E-PB-Widespread-Bathroom-Brushed/dp/B07TWN87HQ>> (Year: 2019).\*

PARLOS Two-Handle Widespread Bathroom Faucet, Date First Available Jan. 5, 2018[online], [site visited Mar. 19, 2021]. Available from internet, URL:<<https://www.amazon.com/Two-Handle-Widespread-Bathroom-Assembly-Brushed/dp/B078V22DLQ>> (Year: 2018).\*

\* cited by examiner

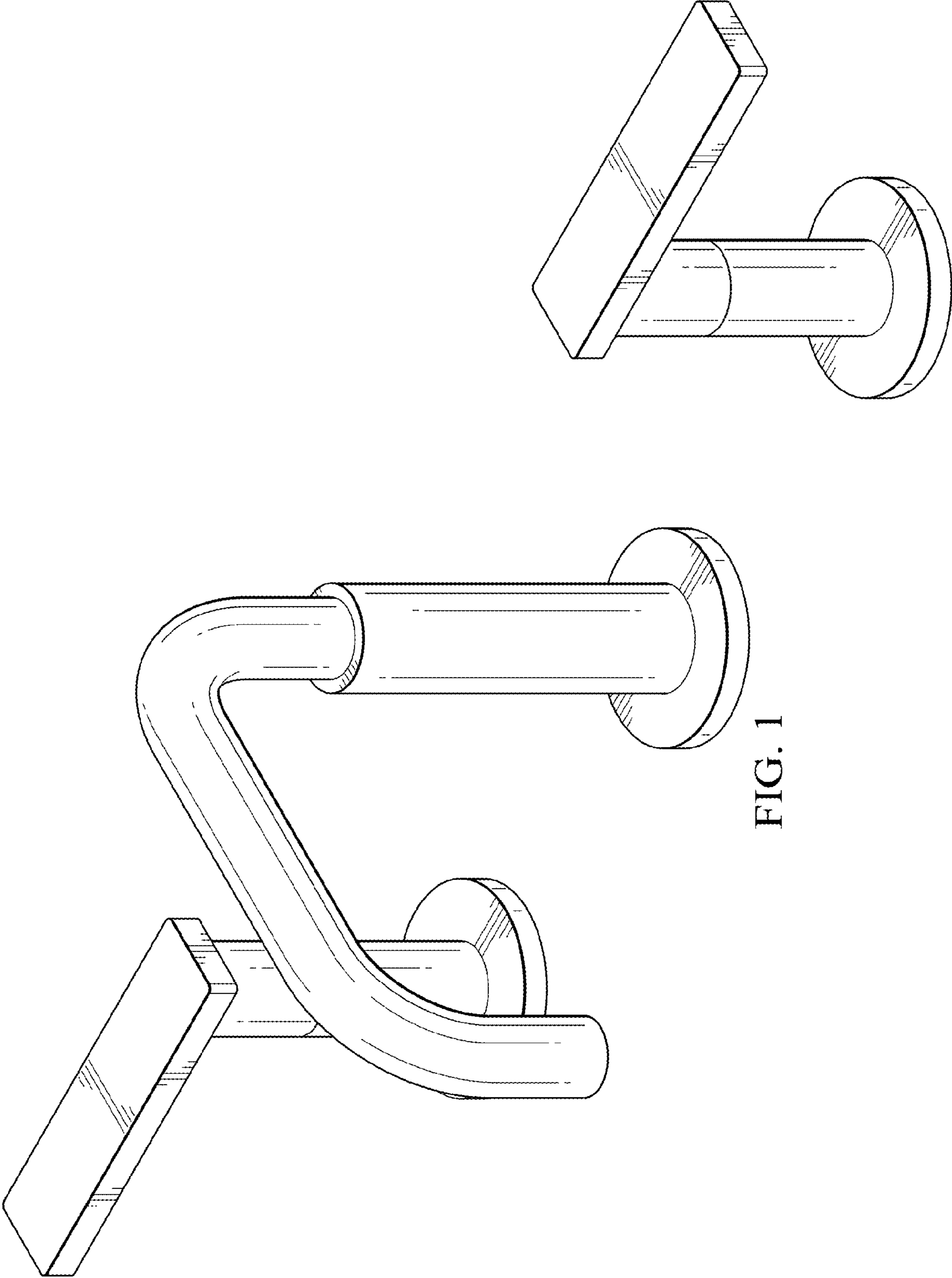

FIG. 1

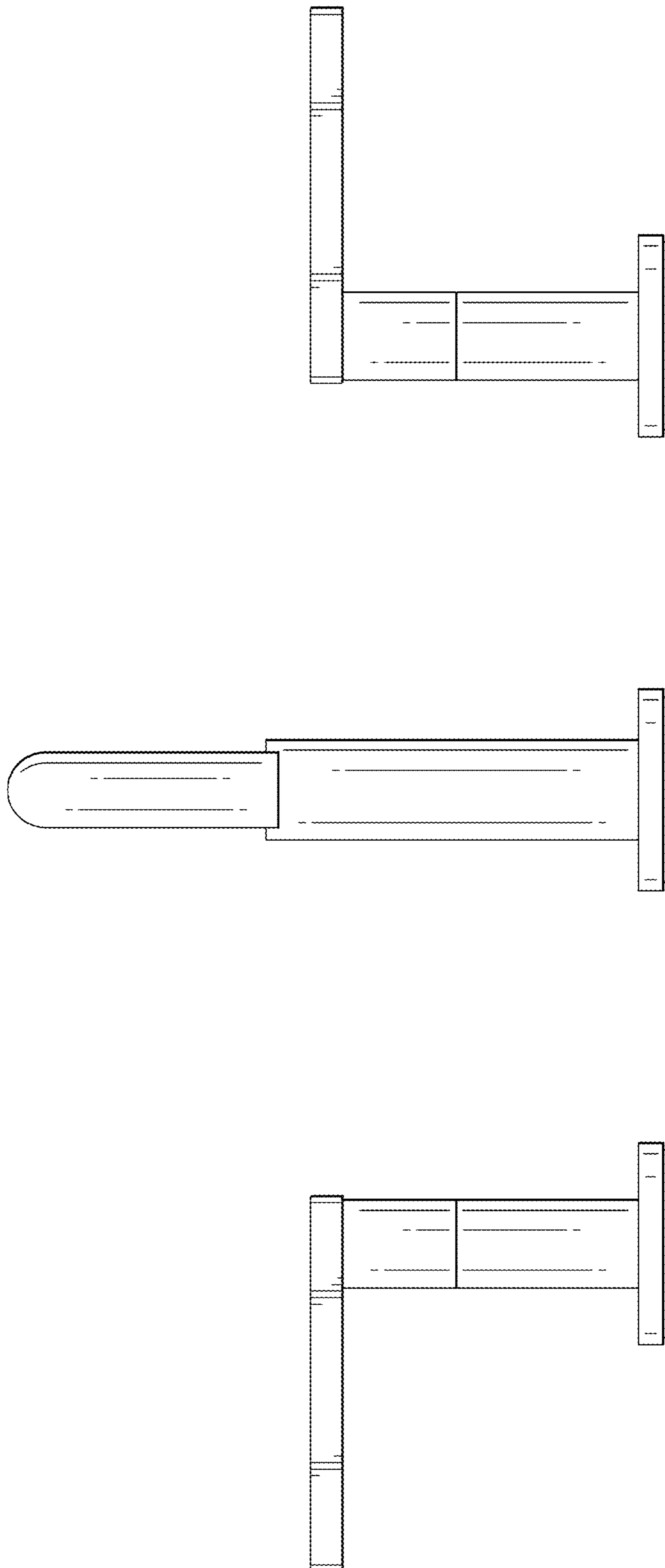

FIG. 2

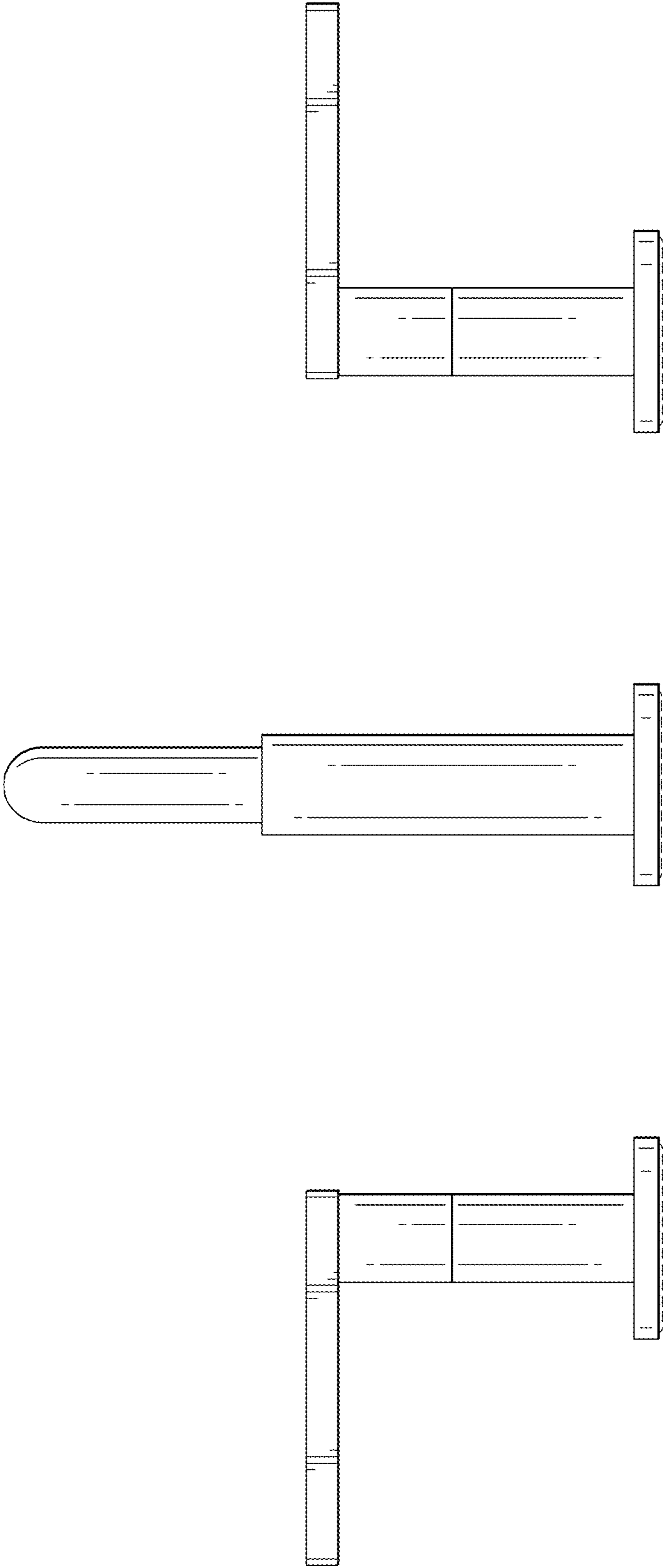

FIG. 3

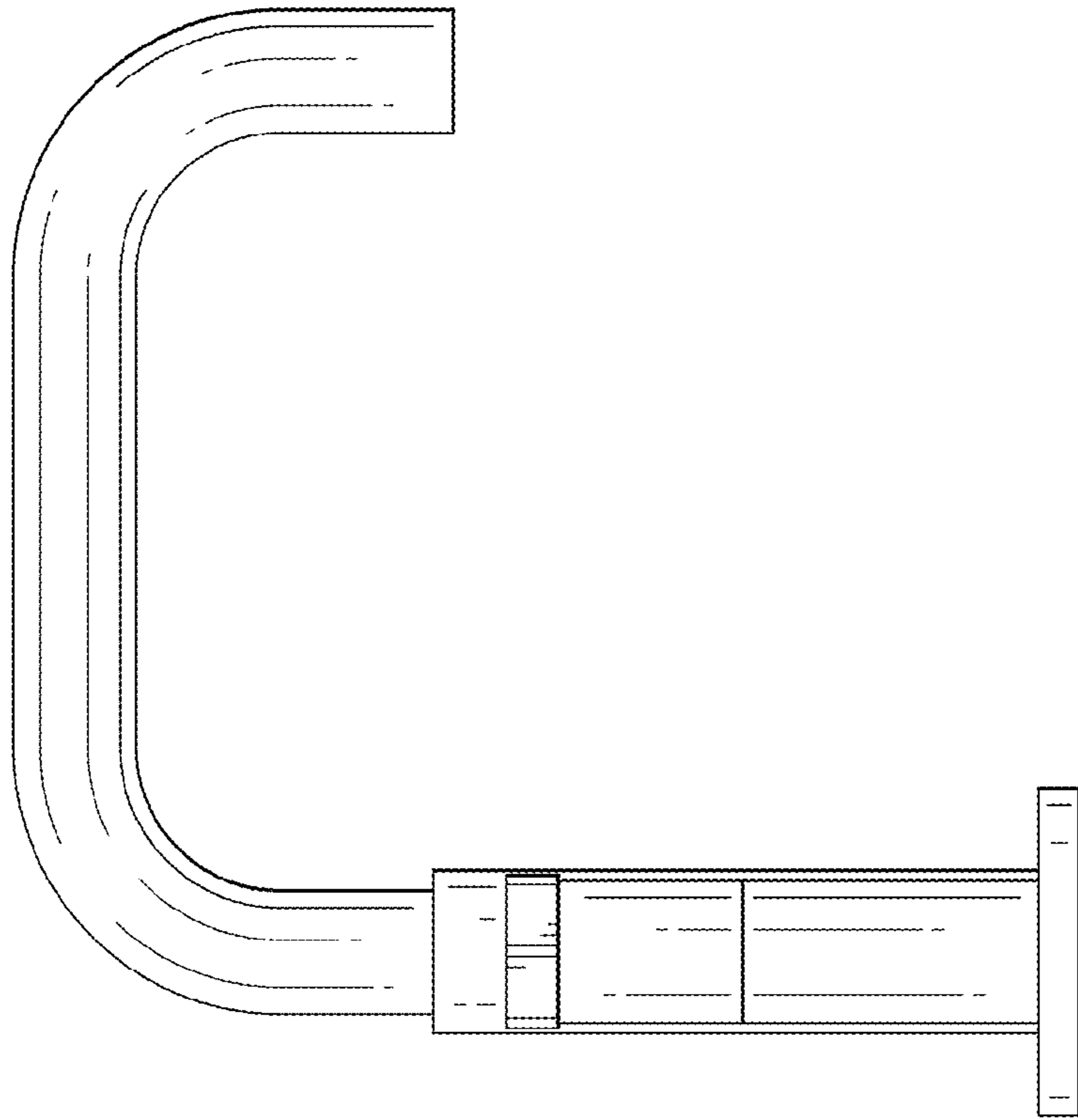

FIG. 5

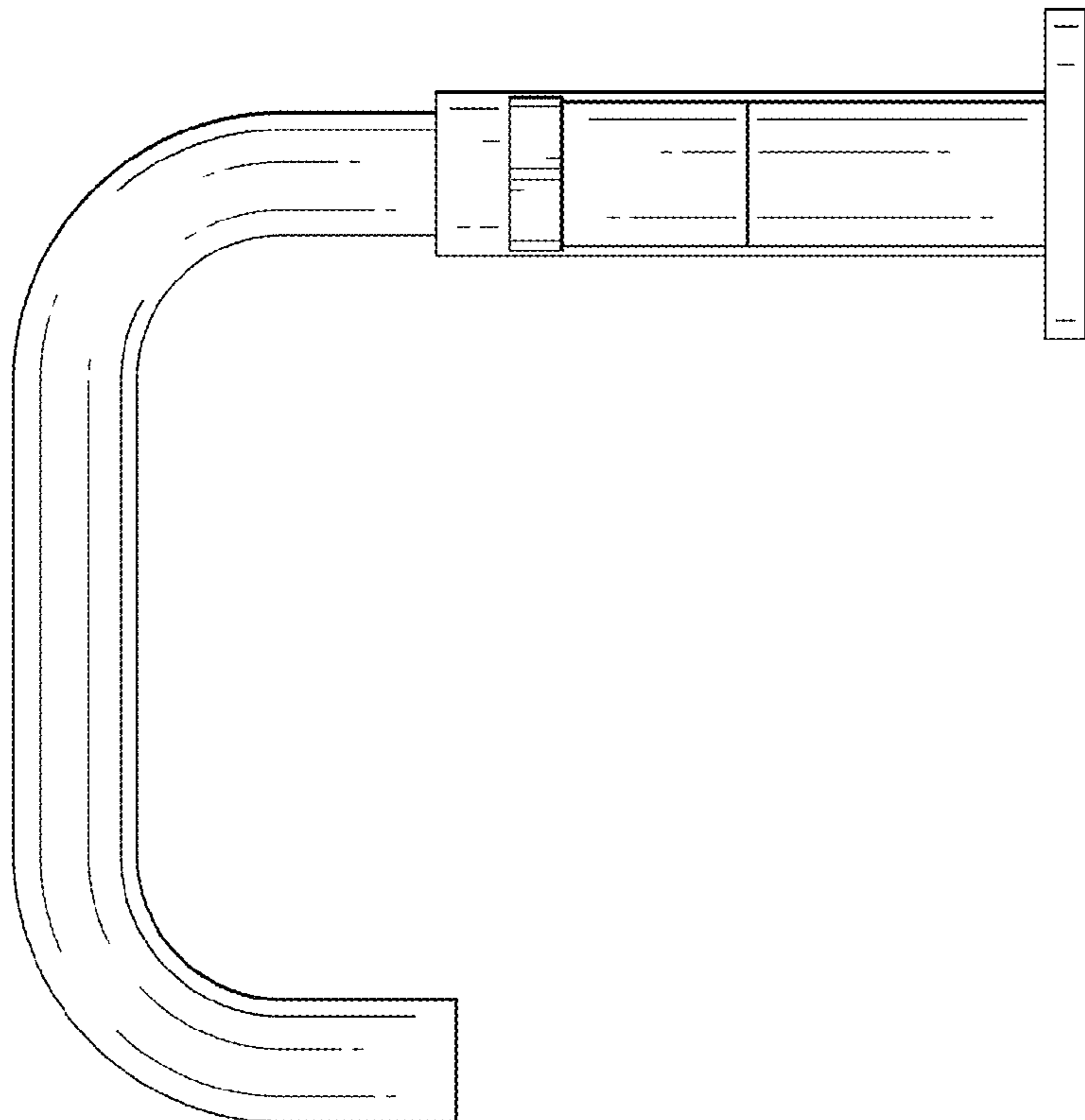

FIG. 4

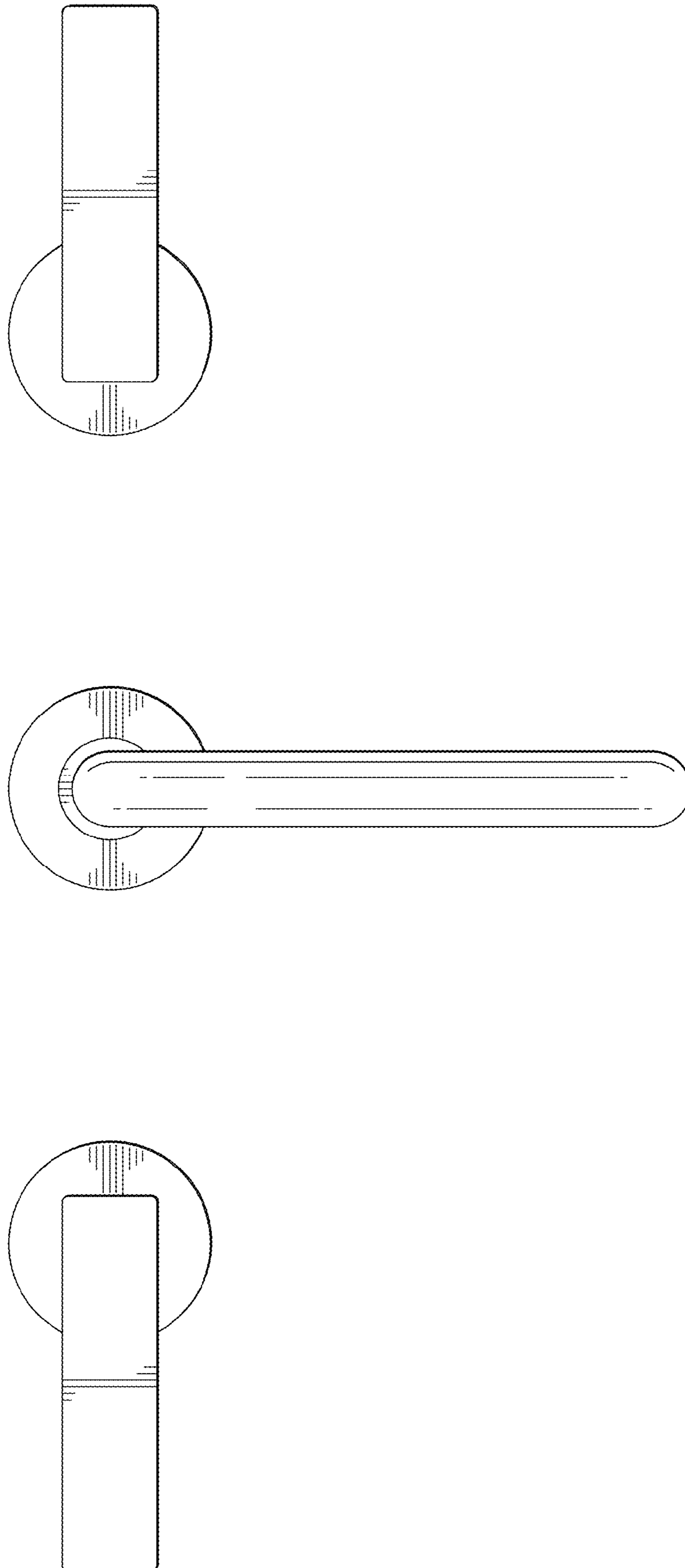

FIG. 6

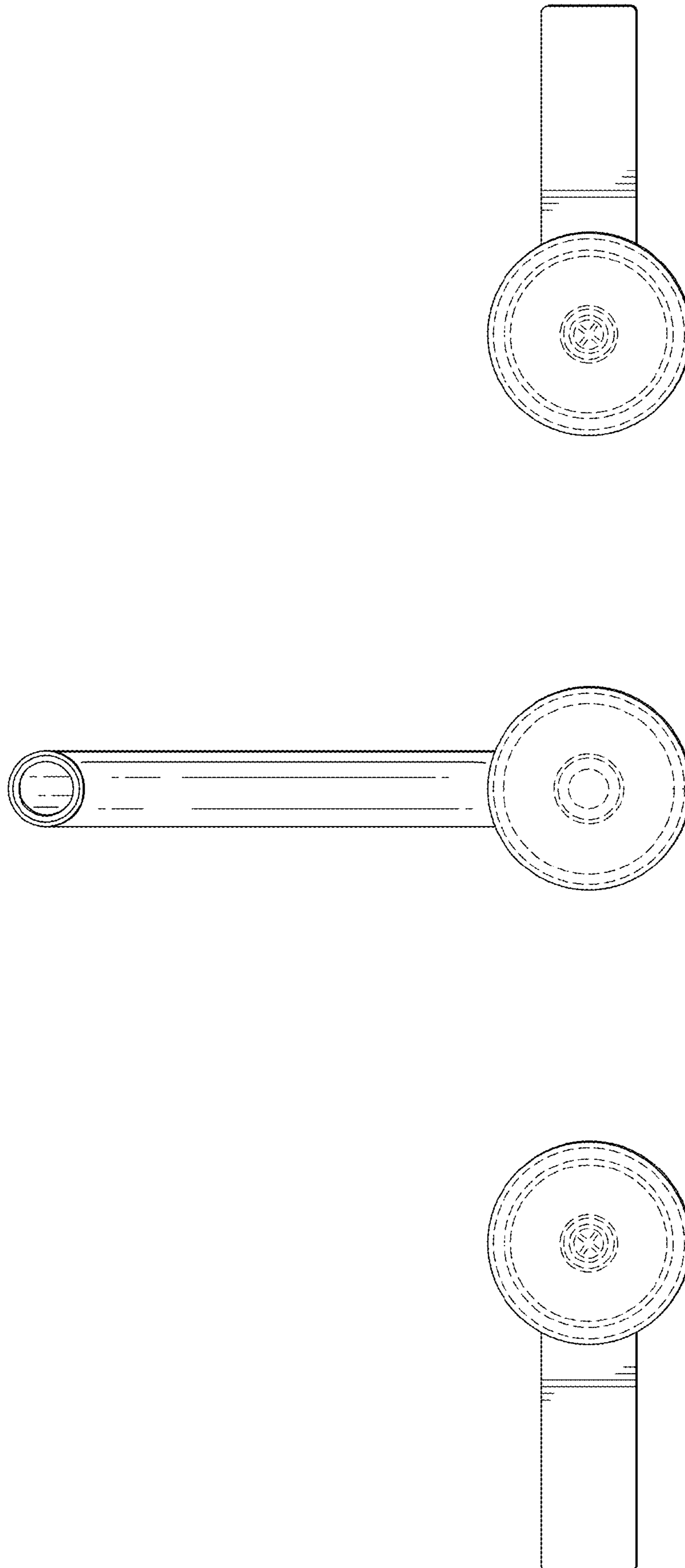

FIG. 7