



US00D941715S

(12) **United States Design Patent**  
**Ozawa et al.**

(10) **Patent No.:** **US D941,715 S**  
(45) **Date of Patent:** **\*\* Jan. 25, 2022**

(54) **FRONT BUMPER FOR AN AUTOMOBILE**

(71) Applicant: **Subaru Corporation**, Tokyo (JP)

(72) Inventors: **Shuji Ozawa**, Tokyo (JP); **Toru Nakano**, Tokyo (JP); **Kouta Kikuchi**, Tokyo (JP)

(73) Assignee: **Subaru Corporation**, Tokyo (JP)

(\*\*) Term: **15 Years**

(21) Appl. No.: **29/727,800**

(22) Filed: **Mar. 13, 2020**

(30) **Foreign Application Priority Data**

Sep. 13, 2019 (JP) ..... 2019-020559

(51) **LOC (13) Cl.** ..... **12-16**

(52) **U.S. Cl.**  
USPC ..... **D12/169**

(58) **Field of Classification Search**  
USPC ..... D12/82, 86, 88, 89, 90, 91, 92, 93, 96,  
D12/163, 164, 165, 166, 167, 169, 170,  
D12/171, 172, 173, 181, 184, 185, 190,  
D12/192, 196, 216, 223, 400; D21/533,  
D21/548, 552, 561

CPC ..... B60R 19/00; B60R 19/02; B60R 19/04;  
B60R 19/16; B60R 19/18; B60R 19/24;  
B60R 19/26; B60R 19/44; B60R 19/48;  
B60R 19/52; B60R 19/56; B60R  
2019/007; B60R 2019/522; B60R  
2019/527; B60R 2019/1886; B62D 25/02;  
B62D 25/08; B62D 25/16

See application file for complete search history.

(56) **References Cited**

**U.S. PATENT DOCUMENTS**

D564,425 S \* 3/2008 Okue ..... D12/169  
D625,230 S \* 10/2010 Hirai ..... D12/169

D637,945 S \* 5/2011 Nakagawa ..... D12/169  
D656,871 S \* 4/2012 Fetherston ..... D12/169  
D686,546 S \* 7/2013 Fetherston ..... D12/169  
D786,748 S \* 5/2017 Hellwig ..... D12/169  
D789,846 S \* 6/2017 Curic ..... D12/169  
D789,850 S \* 6/2017 Svensson ..... D12/169  
D789,851 S \* 6/2017 Svensson ..... D12/169  
D793,921 S \* 8/2017 Takamatsu ..... D12/169  
D800,035 S \* 10/2017 Takamatsu ..... D12/169  
D803,112 S \* 11/2017 Tomita ..... D12/169  
D814,369 S \* 4/2018 Loeb ..... D12/169  
D816,566 S \* 5/2018 Loeb ..... D12/169  
D819,526 S \* 6/2018 Behmer ..... D12/169  
D825,411 S \* 8/2018 Gueler ..... D12/169  
D827,515 S \* 9/2018 Whang ..... D12/169  
D829,617 S \* 10/2018 Takamatsu ..... D12/169  
D829,618 S \* 10/2018 Kamahara ..... D12/169  
D830,250 S \* 10/2018 Tomita ..... D12/169  
D840,295 S \* 2/2019 Peat ..... D12/169  
D841,533 S \* 2/2019 Imai ..... D12/169

(Continued)

*Primary Examiner* — Christian P. McLean

*Assistant Examiner* — Adam C Mager

(74) *Attorney, Agent, or Firm* — Schiff Hardin LLP

(57) **CLAIM**

We claim the ornamental design for a front bumper for an automobile, as shown and described.

**DESCRIPTION**

FIG. 1 is a front perspective view for a “front bumper for an automobile” showing our new design, FIG. 2 is a rear perspective view thereof, FIG. 3 is a front view thereof, FIG. 4 is a rear view thereof, FIG. 5 is a top view thereof, FIG. 6 is a bottom view thereof, FIG. 7 is a left-side view thereof; and, FIG. 8 is a right-side view thereof.

**1 Claim, 4 Drawing Sheets**

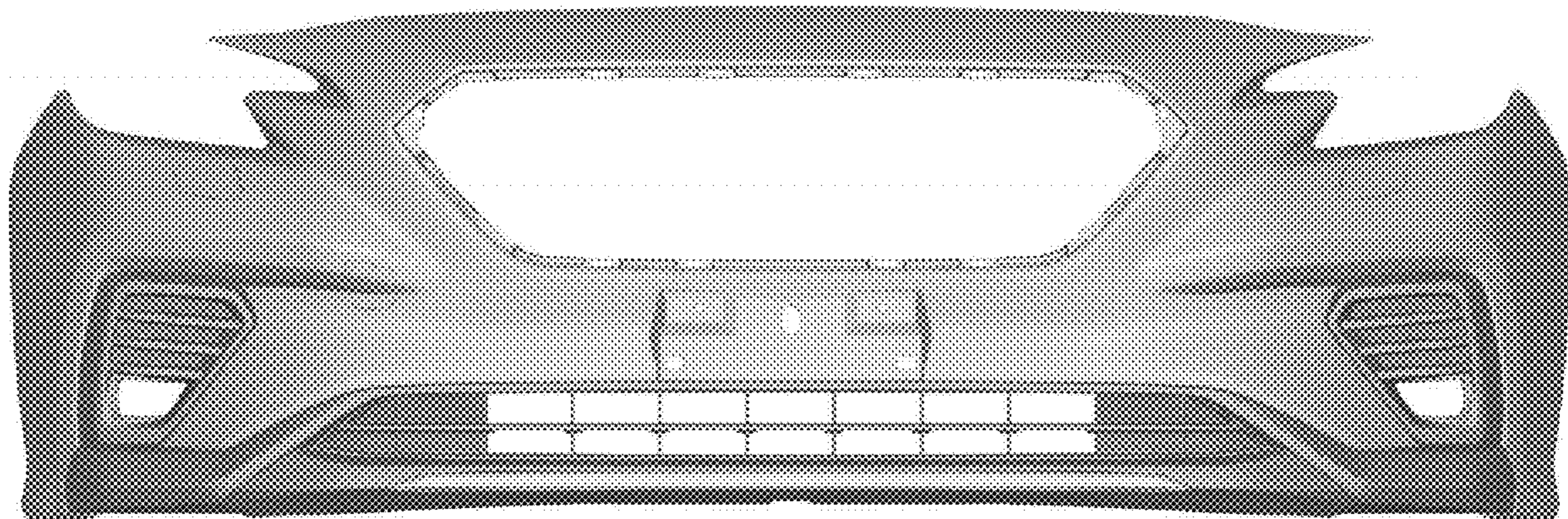

(56)

**References Cited**

U.S. PATENT DOCUMENTS

D843,899	S	*	3/2019	Nakajima	.....	D12/169
D850,990	S	*	6/2019	Metros	.....	D12/169
D850,996	S	*	6/2019	Betancourt	.....	D12/169
D850,997	S	*	6/2019	Messale	.....	D12/169
D851,562	S	*	6/2019	Andoh	.....	D12/169
D866,419	S	*	11/2019	Takamatsu	.....	D12/169
D866,420	S	*	11/2019	Takamatsu	.....	D12/169
D870,610	S	*	12/2019	Tonello	.....	D12/169
D870,612	S	*	12/2019	Tonello	.....	D12/169
D871,982	S	*	1/2020	Tonello	.....	D12/169
D874,343	S	*	2/2020	Kobayashi	.....	D12/91
D889,330	S	*	7/2020	Patel	.....	D12/169
D899,970	S	*	10/2020	Tanaka	.....	D12/91
D899,978	S	*	10/2020	Metros	.....	D12/169
D909,932	S	*	2/2021	Tanaka	.....	D12/169
D909,933	S	*	2/2021	Tanaka	.....	D12/169
D915,957	S	*	4/2021	Bischoff	.....	D12/169
D915,958	S	*	4/2021	Lee	.....	D12/169
D921,545	S	*	6/2021	Fuchino	.....	D12/169

\* cited by examiner

Fig. 1

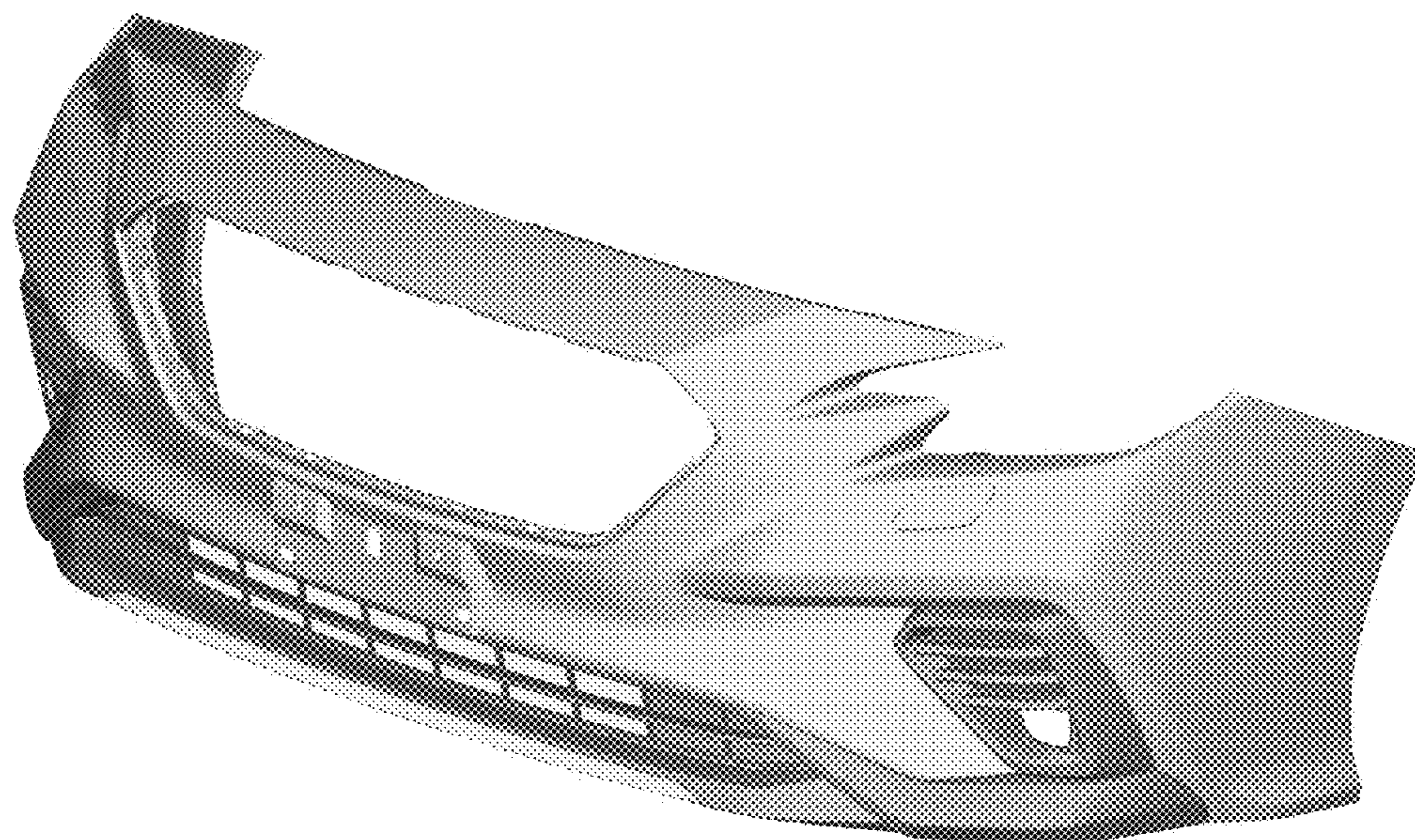

Fig. 2

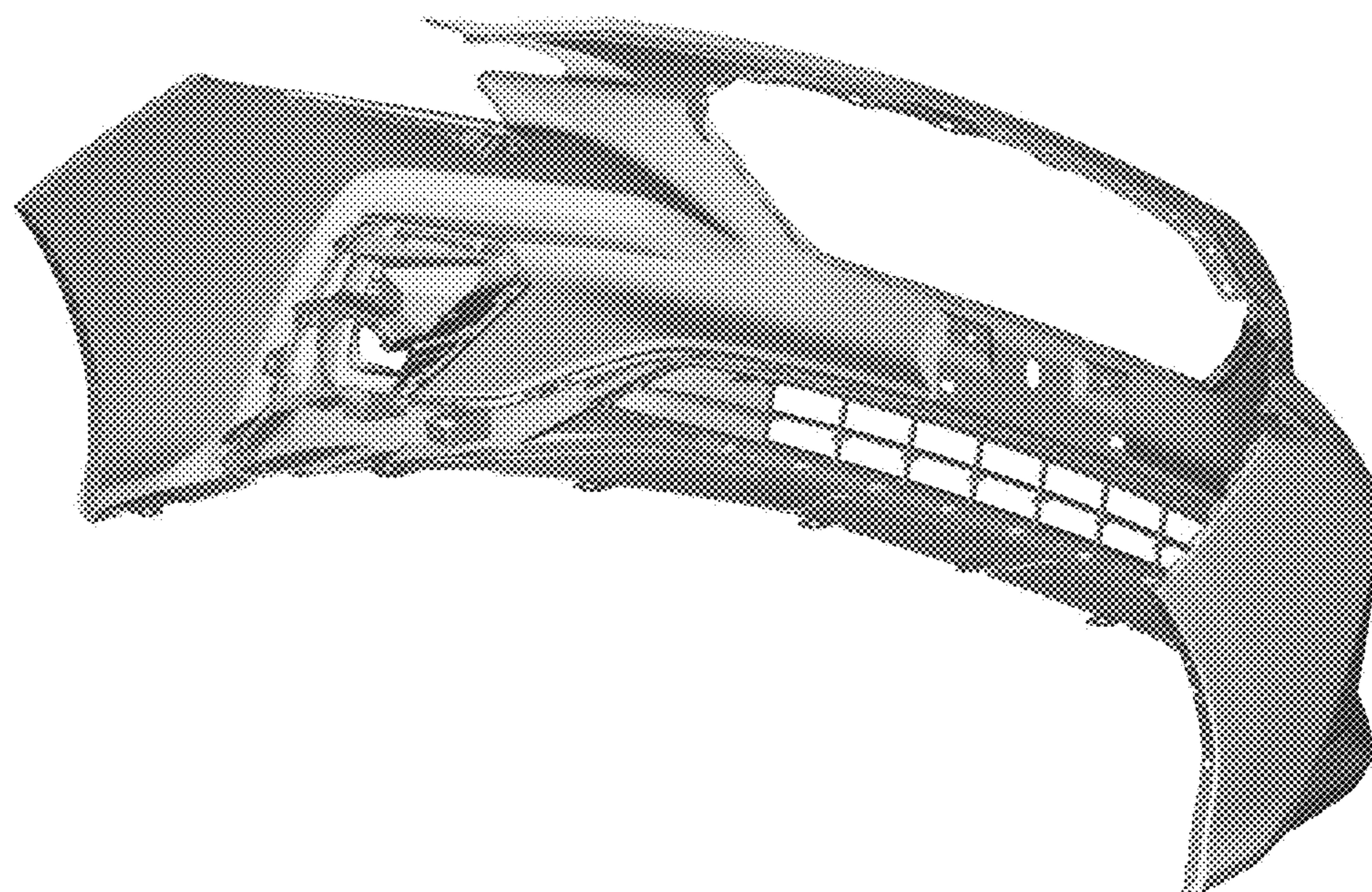

Fig. 3

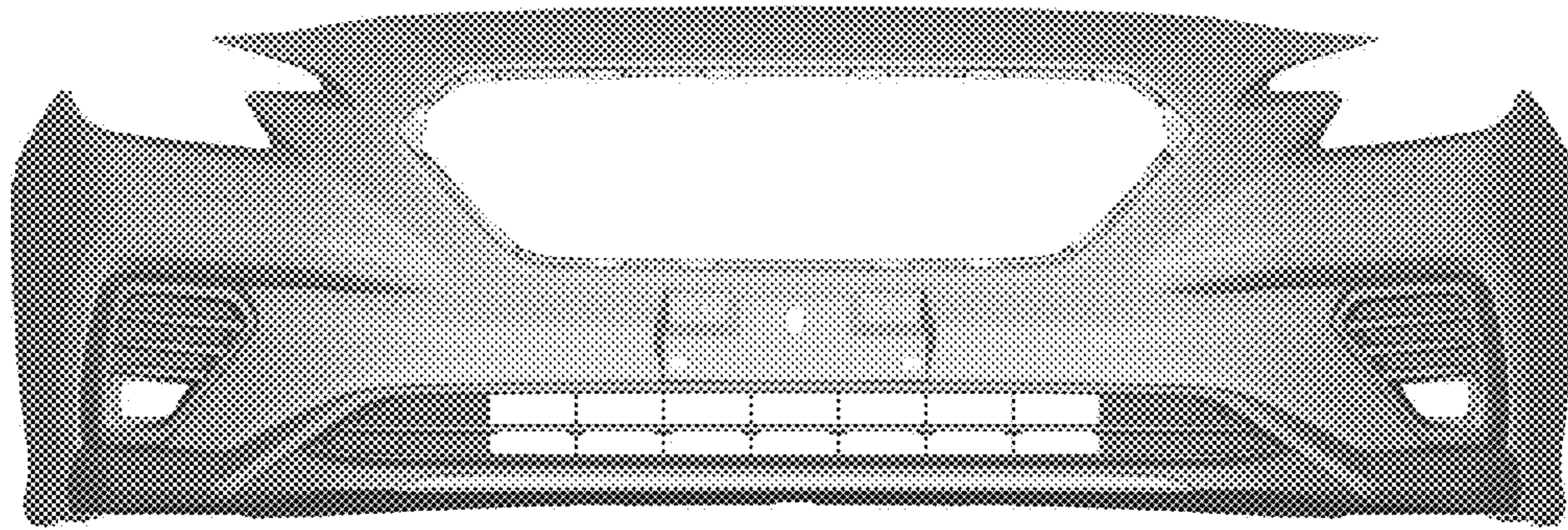

Fig. 4

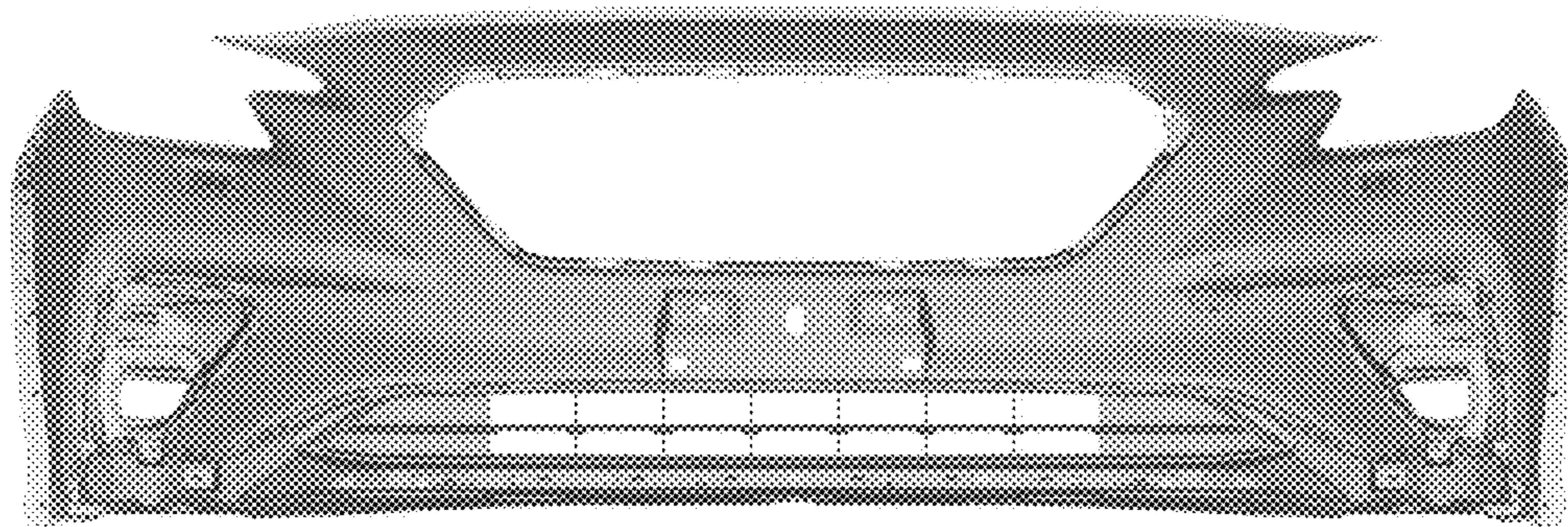

Fig. 5

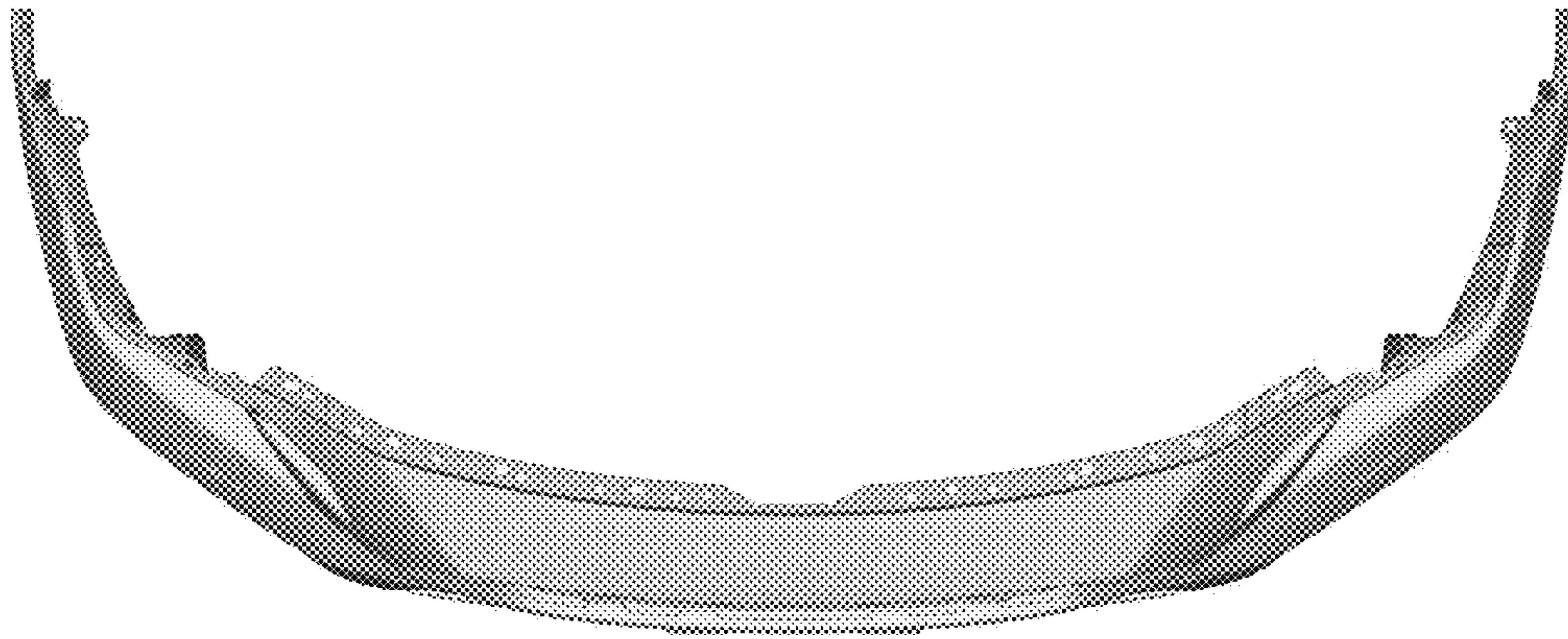

Fig. 6

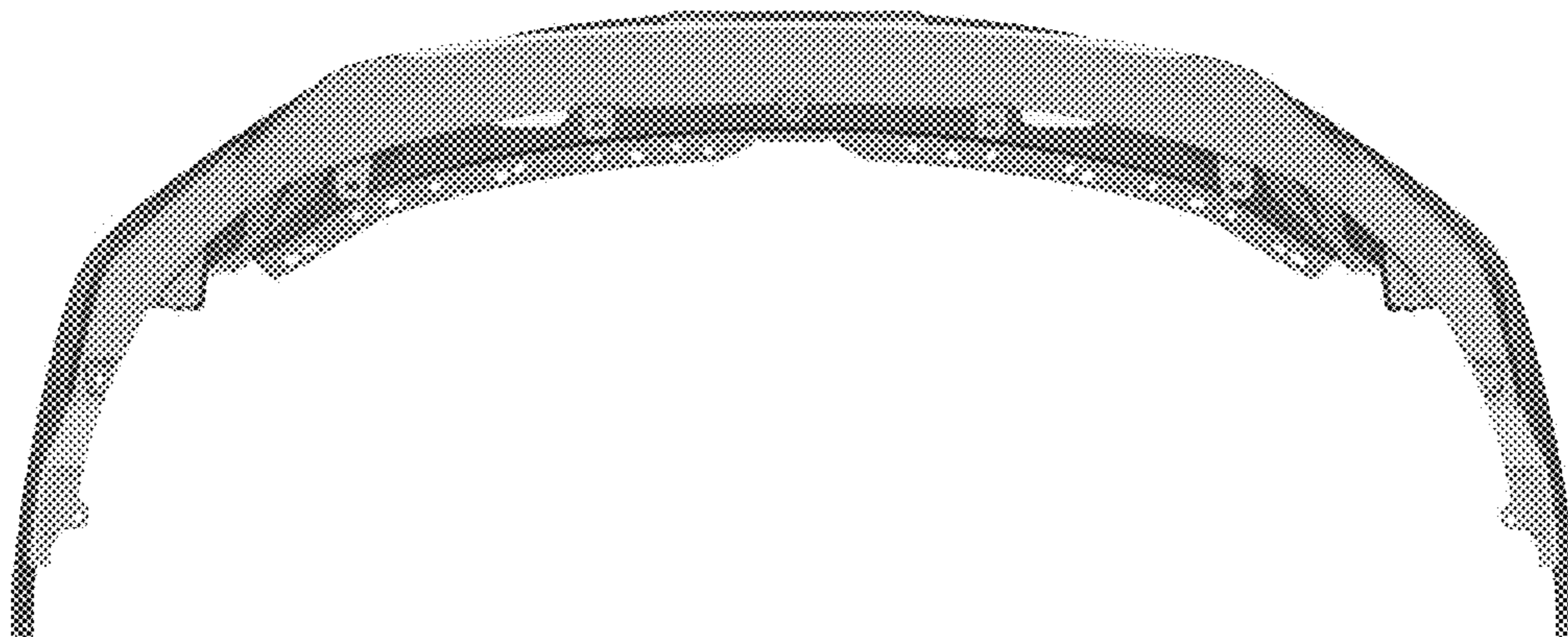

Fig. 7

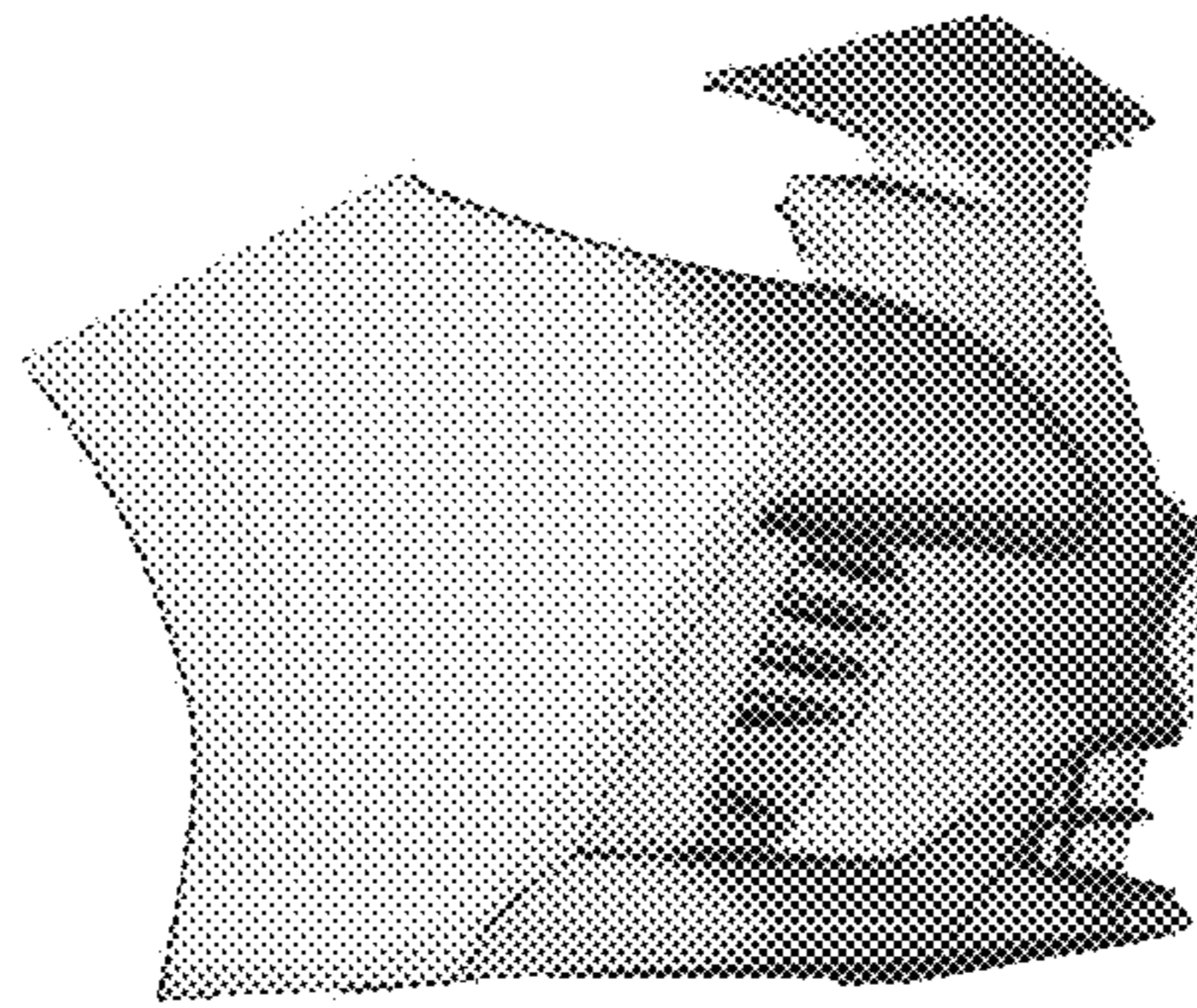

Fig. 8

