



US00D941706S

(12) **United States Design Patent**  
**Kim et al.**

(10) **Patent No.:** **US D941,706 S**  
(45) **Date of Patent:** **\*\* Jan. 25, 2022**

(54) **VEHICLE BODY**

(71) Applicant: **Canoo Technologies Inc.**, Torrance, CA (US)

(72) Inventors: **Richard Kim**, Los Angeles, CA (US); **Brian Oh**, Rancho Palos Verdes, CA (US); **Jackson E. Luttig**, Rancho Palos Verdes, CA (US); **Brian Spencer**, Lakewood, CA (US); **Noah Hammersten**, Studio City, CA (US)

(73) Assignee: **Canoo Technologies Inc.**, Torrance, CA (US)

(\*\*) Term: **15 Years**

(21) Appl. No.: **29/746,628**

(22) Filed: **Aug. 14, 2020**

**Related U.S. Application Data**

(63) Continuation of application No. 29/742,026, filed on Sep. 24, 2019.

(51) **LOC (13) Cl.** ..... **12-08**

(52) **U.S. Cl.**  
USPC ..... **D12/86**

(58) **Field of Classification Search**  
USPC ..... D12/1, 14, 82, 86, 93-100; D21/533, D21/552-560  
CPC ..... B60F 3/0061; B62D 35/00; B62D 33/00; B62D 25/00; B62D 25/06; B62D 33/06; B62D 33/0607; B62D 33/0621; B62D 33/0625; B62D 39/00; B62D 49/005; B62D 49/007

See application file for complete search history.

(56) **References Cited**

**U.S. PATENT DOCUMENTS**

D238,799 S \* 2/1976 Goldfarb ..... D21/556  
D262,391 S \* 12/1981 Kanaoki ..... D21/450

D274,637 S \* 7/1984 Terui ..... D21/552  
D457,467 S \* 5/2002 Shimizu ..... D12/86  
D800,017 S \* 10/2017 Sapet ..... D12/86  
D832,742 S \* 11/2018 Fisker ..... D12/86  
D839,784 S \* 2/2019 Sugawara ..... D12/86  
D860,862 S \* 9/2019 Janin ..... D12/90  
D875,185 S \* 2/2020 Zeng ..... D21/552  
10,769,940 B2 \* 9/2020 Hur ..... B60W 30/18109  
10,821,776 B1 \* 11/2020 Labadie ..... B60B 3/10  
10,829,145 B2 \* 11/2020 Washnock ..... F16H 19/04  
10,870,361 B2 \* 12/2020 Hara ..... H01M 8/04201  
10,951,044 B2 \* 3/2021 Choi ..... H02J 7/0013  
10,959,892 B2 \* 3/2021 Yamada ..... A61G 5/04  
10,974,582 B2 \* 4/2021 Hara ..... B60K 1/04

(Continued)

**OTHER PUBLICATIONS**

Electric Vehicle. (Design—© Questel) orbit.com. [Online PDF compilation of references] 49 pgs. Print Dates Range Jan. 20, 2021-Mar. 28, 2019 [Retrieved Jun. 29, 2021].\*

(Continued)

*Primary Examiner* — Manpreet S Matharu  
*Assistant Examiner* — Suzanne E Tisdell

(57) **CLAIM**

The ornamental design for a vehicle body, as shown and described.

**DESCRIPTION**

FIG. 1 is a front view of a vehicle body, according to an embodiment of the invention;  
FIG. 2 is a rear view thereof;  
FIG. 3 is a left side view thereof;  
FIG. 4 is right side view thereof;  
FIG. 5 is a top view thereof; and,  
FIG. 6 is a perspective view thereof.  
Features shown in broken lines do not form part of the claimed design.

**1 Claim, 6 Drawing Sheets**

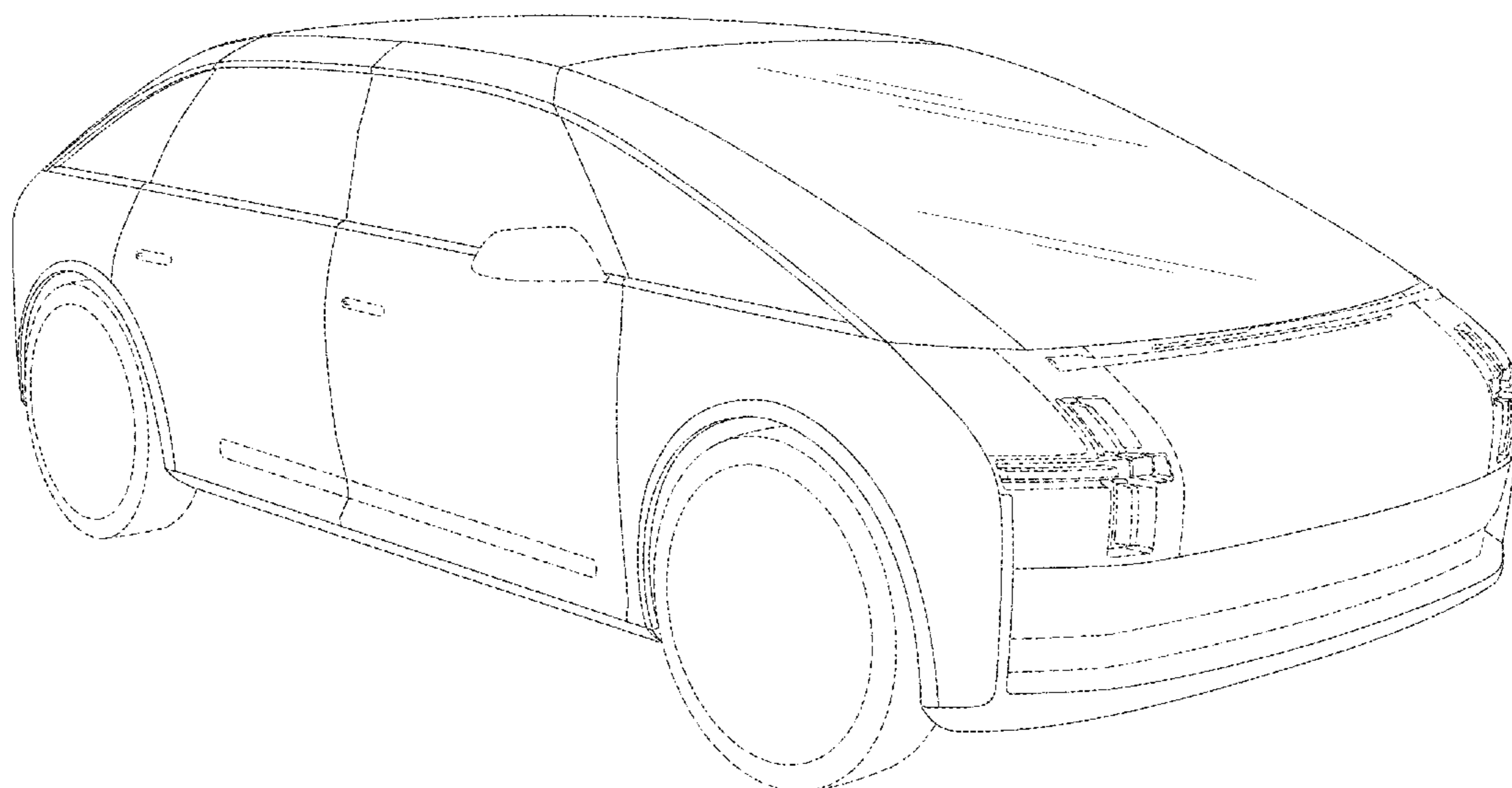

(56)

**References Cited**

U.S. PATENT DOCUMENTS

10,983,199 B2 \* 4/2021 Adams ..... G01S 7/4972  
11,034,254 B2 \* 6/2021 Booth ..... H02J 7/0027  
11,040,609 B2 \* 6/2021 Hara ..... G05D 1/021

OTHER PUBLICATIONS

Reynolds, Kim. "The Canoo Electric Car: 6 Thoughts After Visiting the EV Startup." Aug. 17, 2019. Motor Trend, <https://www.motortrend.com/news/canoo-electric-car-6-thoughts-ev-startup/>.\*

Abuelsamid, Sam. "Introducing Canoo, No Paddles Required for This Electric Van." Sep. 24, 2019. Forbes. <https://www.forbes.com/sites/samabuelsamid/2019/09/24/introducing-canoo-no-paddles-required-for-this-electric-van/?sh=3a231b27641d>.\*

O’Kane, Sean. "Canoo’s First Subscription-Only EV is a Refreshing Rethink of the VW Microbus." Sep. 24, 2019. The Verge. <https://www.theverge.com/2019/9/24/20882538/canoo-evelozcity-ev-subscription-electric-vehicle>.\*

\* cited by examiner

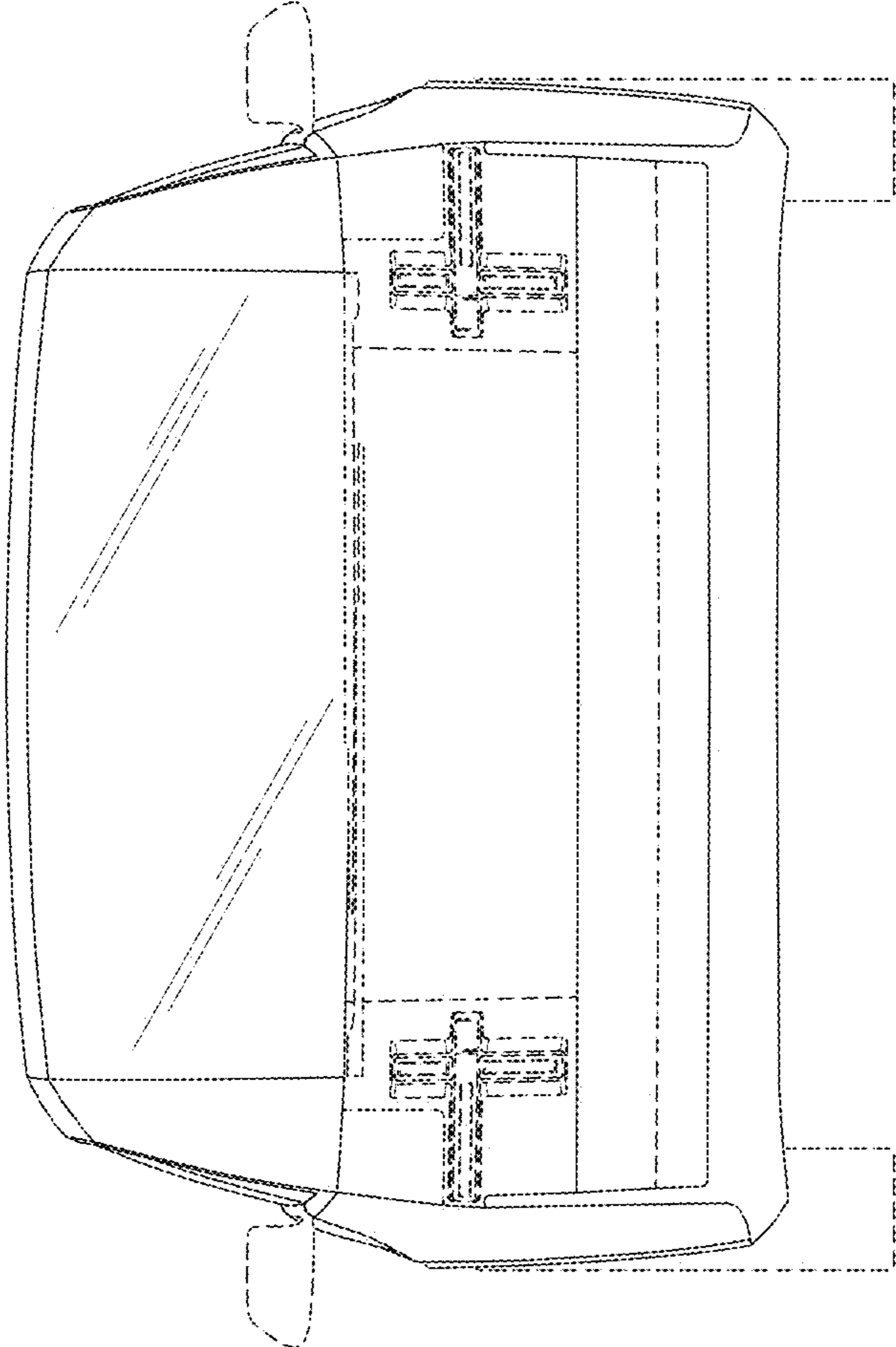

Fig. 1

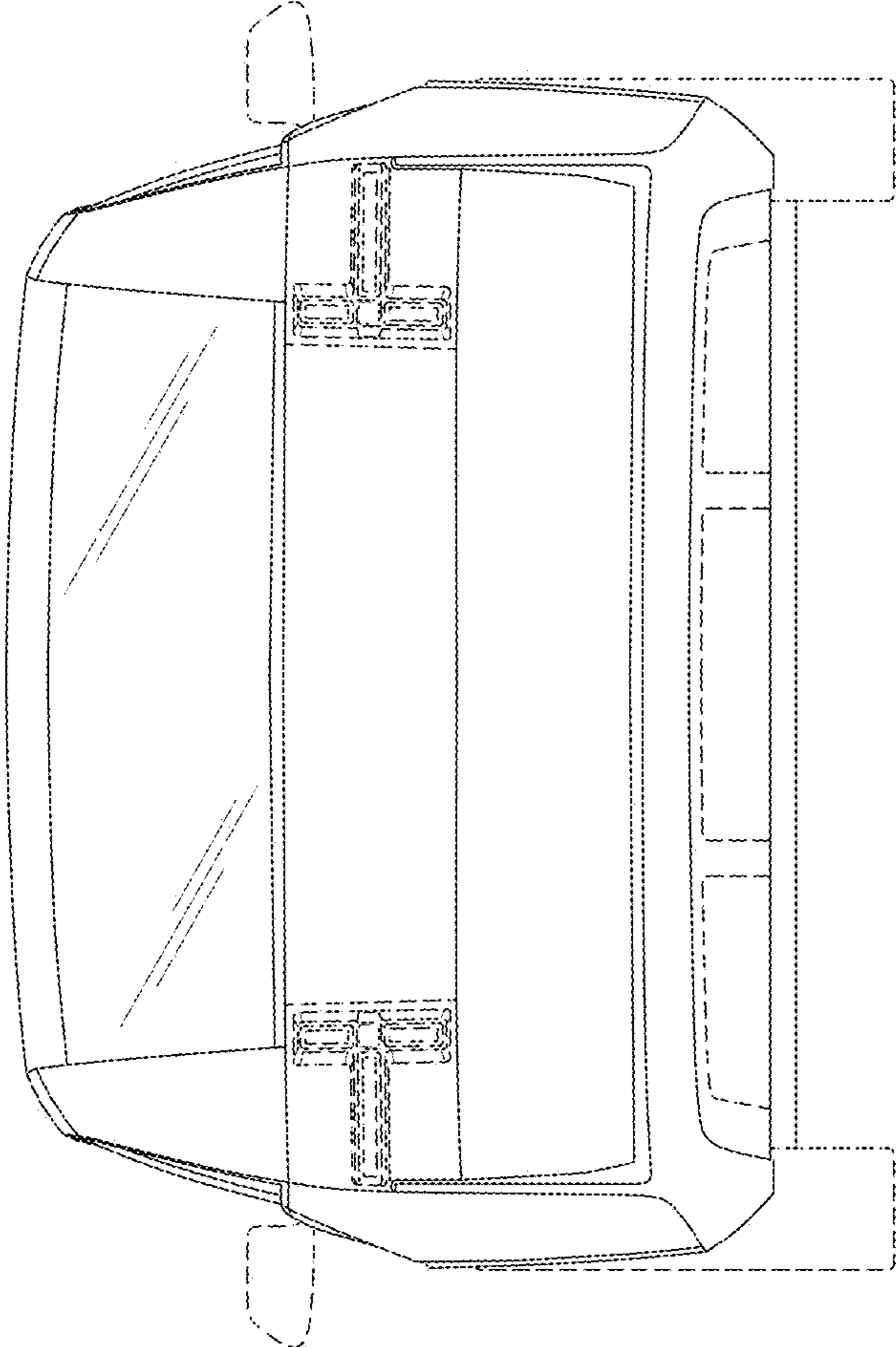

Fig. 2

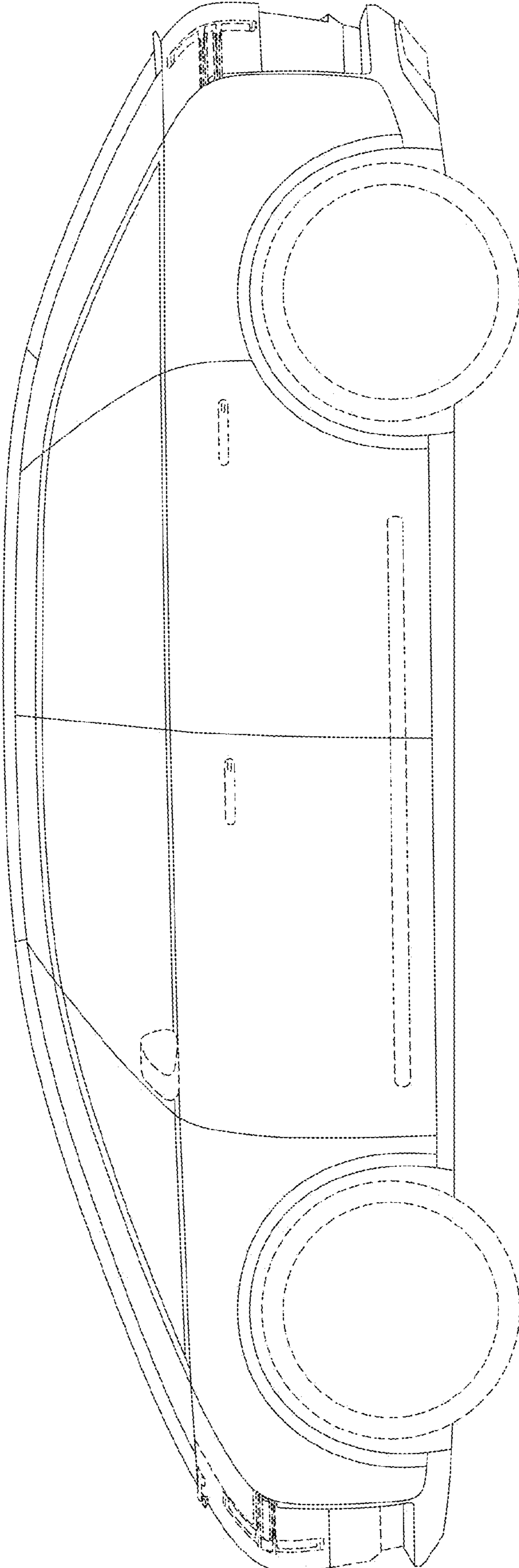

FIG. 3

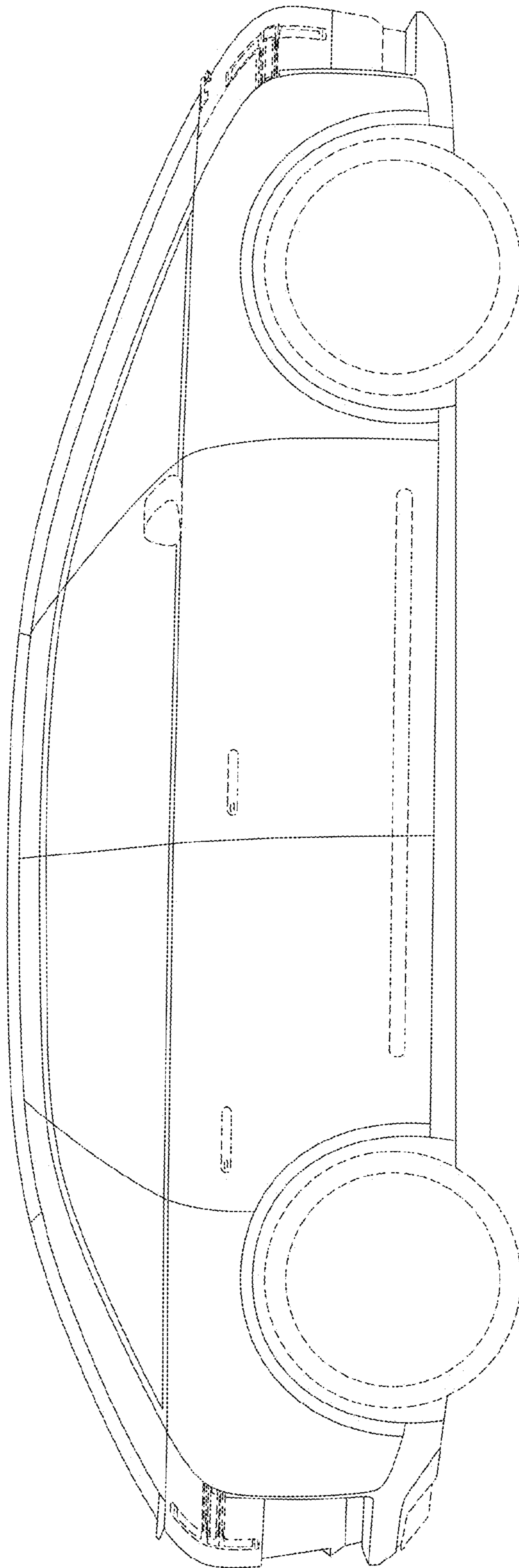

Fig. 4

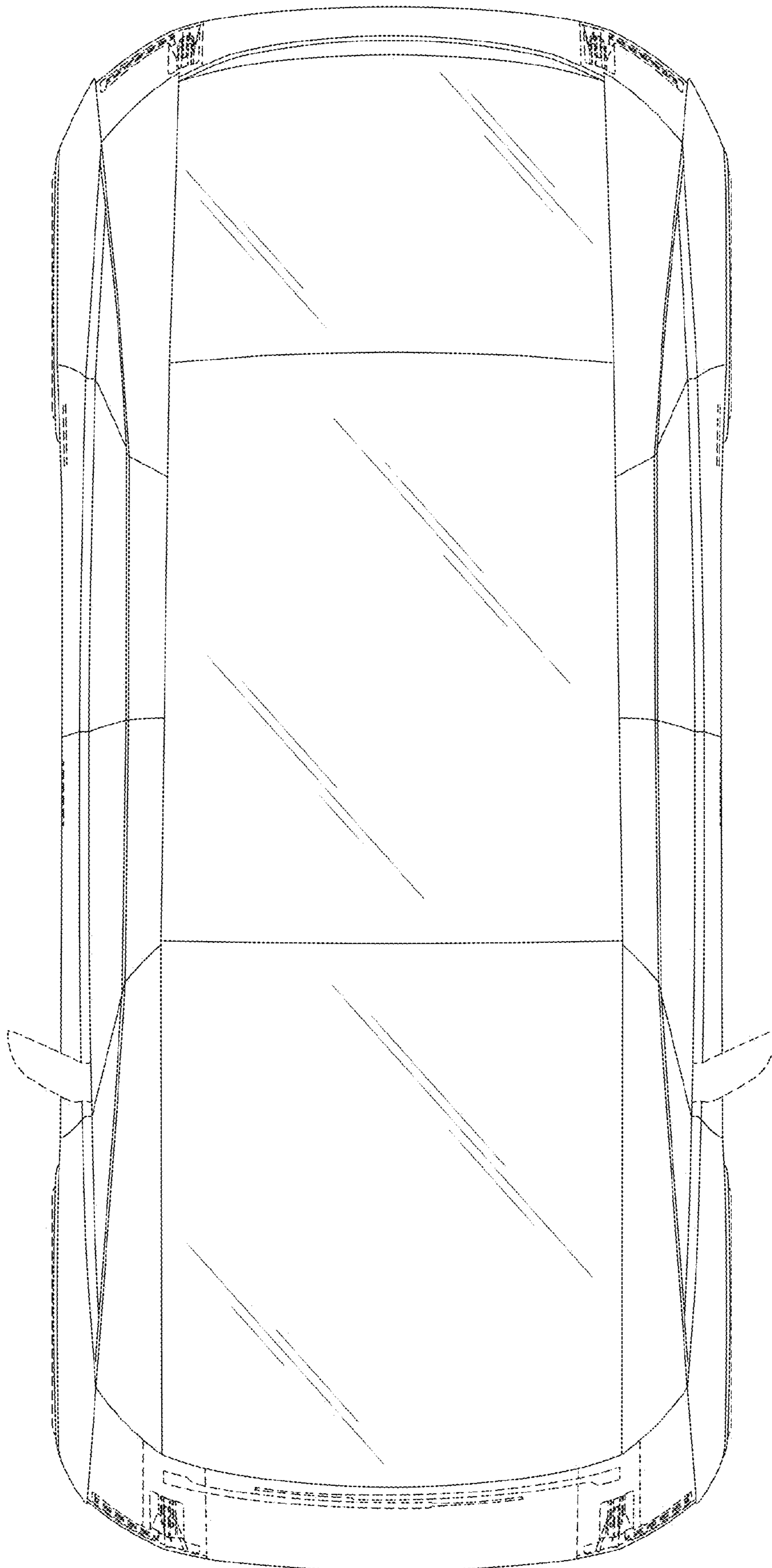

Fig. 5

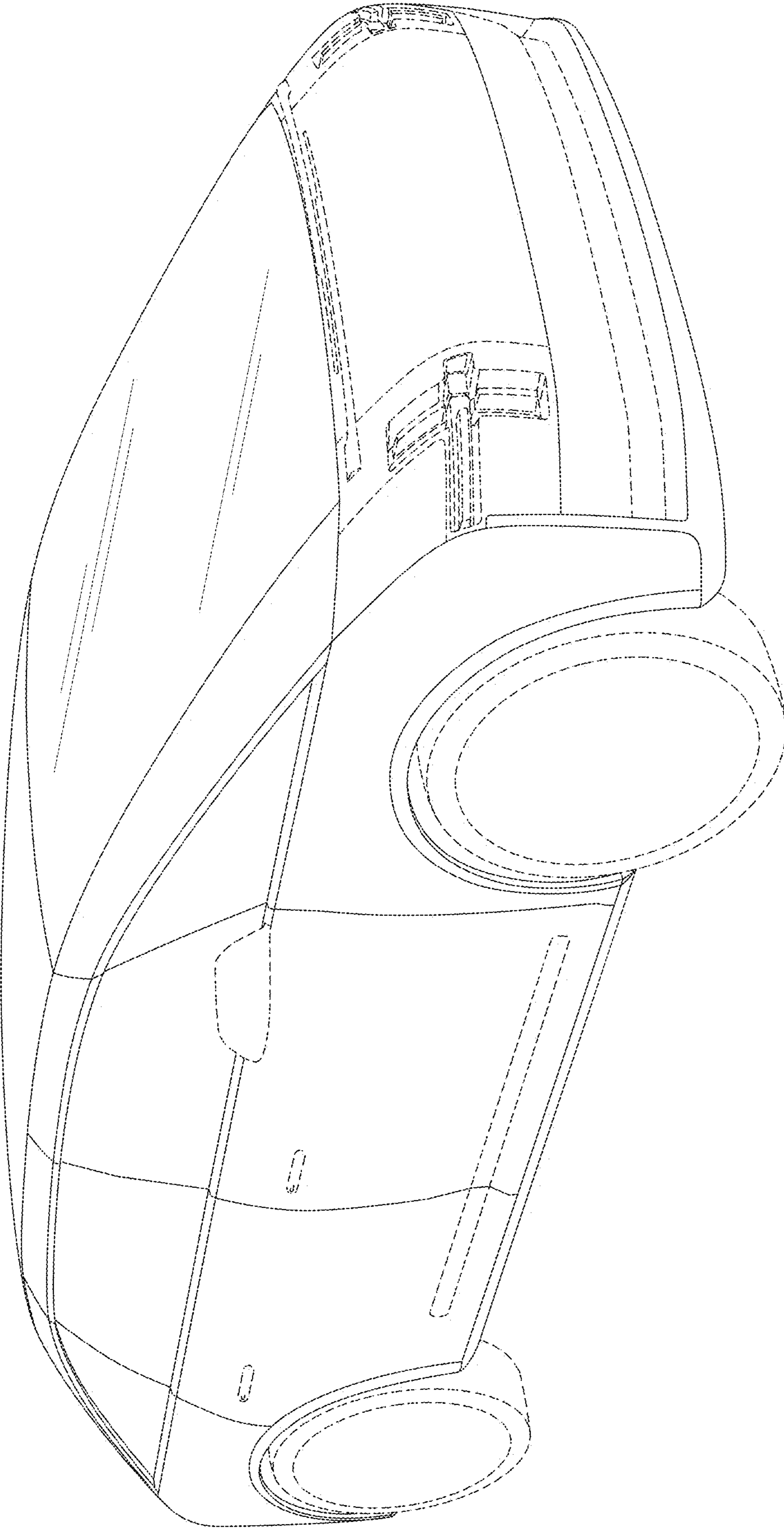

Fig. 6