



US00D941380S

(12) **United States Design Patent**
Koshiishi

(10) **Patent No.:** **US D941,380 S**

(45) **Date of Patent:** **** Jan. 18, 2022**

(54) **SELF-TRAVELING ROBOT**

(71) Applicant: **HONDA MOTOR CO., LTD.**, Tokyo
(JP)

(72) Inventor: **Takeshi Koshiishi**, Wako (JP)

(73) Assignee: **HONDA MOTOR CO., LTD.**, Tokyo
(JP)

(**) Term: **15 Years**

(21) Appl. No.: **29/741,186**

(22) Filed: **Jul. 10, 2020**

(30) **Foreign Application Priority Data**

Jan. 10, 2020 (JP) 2020-000301 D

(51) **LOC (13) Cl.** **15-99**

(52) **U.S. Cl.**
USPC **D15/199**

(58) **Field of Classification Search**
USPC D15/199; D21/578-583, 621, 622
CPC B25J 5/007; B60B 19/006; B62D 57/024;
H01F 7/0221; Y10S 901/01
See application file for complete search history.

(56) **References Cited**

U.S. PATENT DOCUMENTS

D285,599 S *	9/1986	Forino	D21/578
D295,891 S *	5/1988	Shin-Ching	D23/364
D370,704 S *	6/1996	Oberhoff	D21/684
D378,016 S *	2/1997	Armbruster	D3/205
D450,788 S *	11/2001	Kawasaki	D21/578
D661,192 S *	6/2012	Hwang	D9/504
D710,953 S *	8/2014	Katsutani	D21/578
D754,653 S *	4/2016	Marciniak	D14/314
D799,575 S *	10/2017	Tang	D15/199
D809,040 S *	1/2018	Webb, II	D15/199
D809,044 S *	1/2018	Loew	D16/202

D810,167 S *	2/2018	Yang	D15/199
D813,926 S *	3/2018	Shin	D16/203
D824,442 S *	7/2018	Du	D15/199
D835,693 S *	12/2018	Lee	D15/199
D838,758 S *	1/2019	Kymm	D15/199
D851,149 S *	6/2019	Koshiishi	D15/199
D862,550 S *	10/2019	Shu	D15/199
D877,224 S *	3/2020	Koshiishi	D15/199
D878,441 S *	3/2020	Hayashi	D15/199
D881,249 S *	4/2020	Kim	D15/199
D887,467 S *	6/2020	Pak	D15/199
D888,121 S *	6/2020	Kim	D15/199
D894,987 S *	9/2020	Li	D15/199
D895,606 S *	9/2020	Matoba	D14/314
D906,391 S *	12/2020	Chou	D15/199
D908,151 S *	1/2021	Song	D15/199
D915,486 S *	4/2021	Gidwell	D15/199

(Continued)

Primary Examiner — Patricia A Palasik

(74) *Attorney, Agent, or Firm* — Westerman, Hattori,
Daniels & Adrian, LLP

(57) **CLAIM**

The ornamental design for a self-traveling robot, as shown and described.

DESCRIPTION

FIG. 1 is a first perspective view of a self-traveling robot, showing my new design;
FIG. 2 is a second perspective view thereof;
FIG. 3 is a front elevational view thereof;
FIG. 4 is a rear elevational view thereof;
FIG. 5 is a top plan view thereof;
FIG. 6 is a bottom plan view thereof;
FIG. 7 is a right side elevational view thereof; and,
FIG. 8 is a left side elevational view thereof.
The broken lines shown in the drawings illustrate portions of the self-traveling robot that are environmental structures and form no part of the claimed design. Grayscale shading illustrates contour, not any particular color.

1 Claim, 8 Drawing Sheets

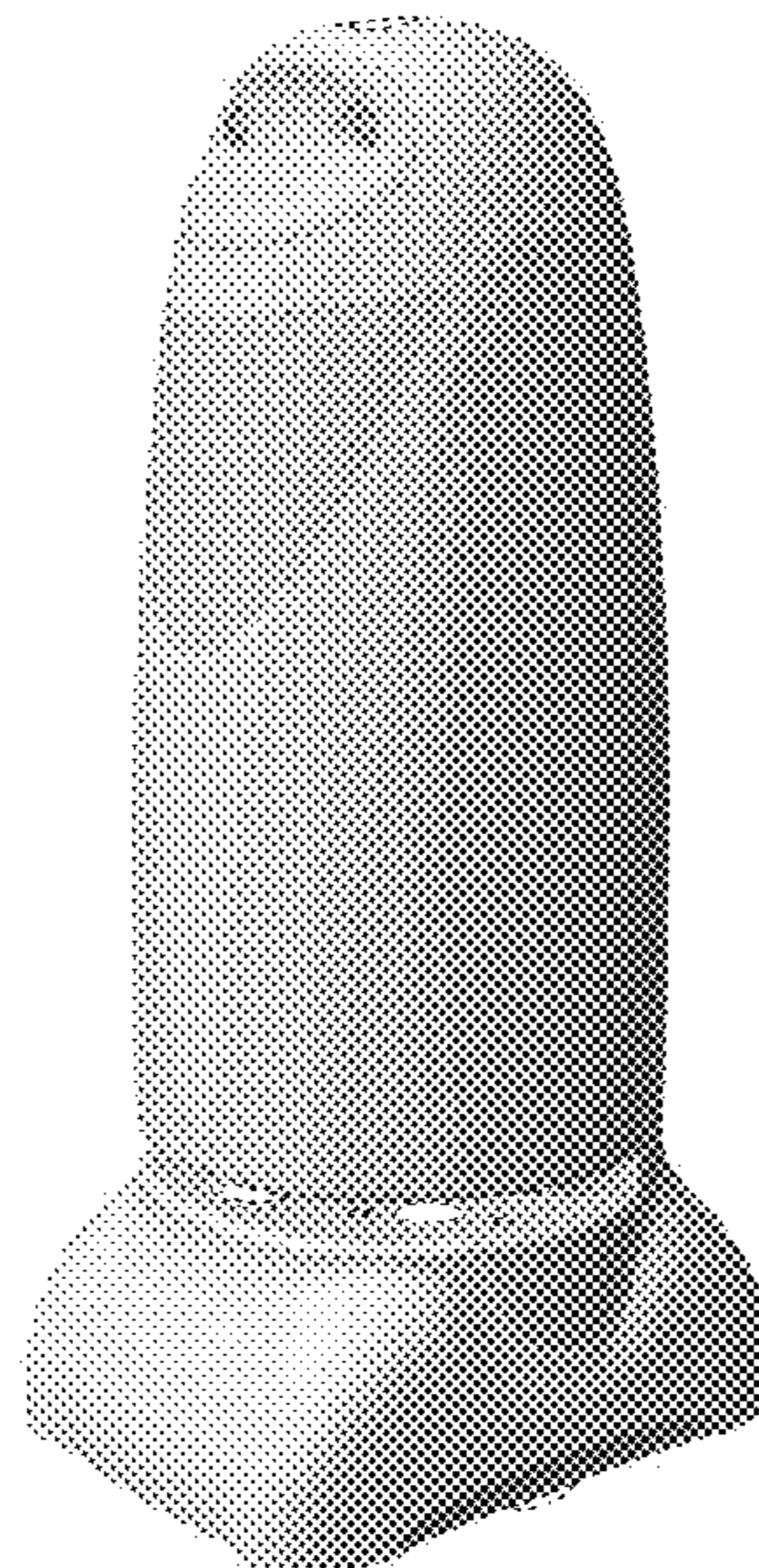

(56)

References Cited

U.S. PATENT DOCUMENTS

D916,161 S *	4/2021	Michaelian	D15/199
D920,411 S *	5/2021	Zheng	D15/199
D922,465 S *	6/2021	Lee	B25J 11/00
			D15/199
D923,681 S *	6/2021	Lee	G05D 1/024
			D15/199
2016/0346917 A1 *	12/2016	Ho	B25J 13/085
2017/0136631 A1 *	5/2017	Li	G06N 20/00

* cited by examiner

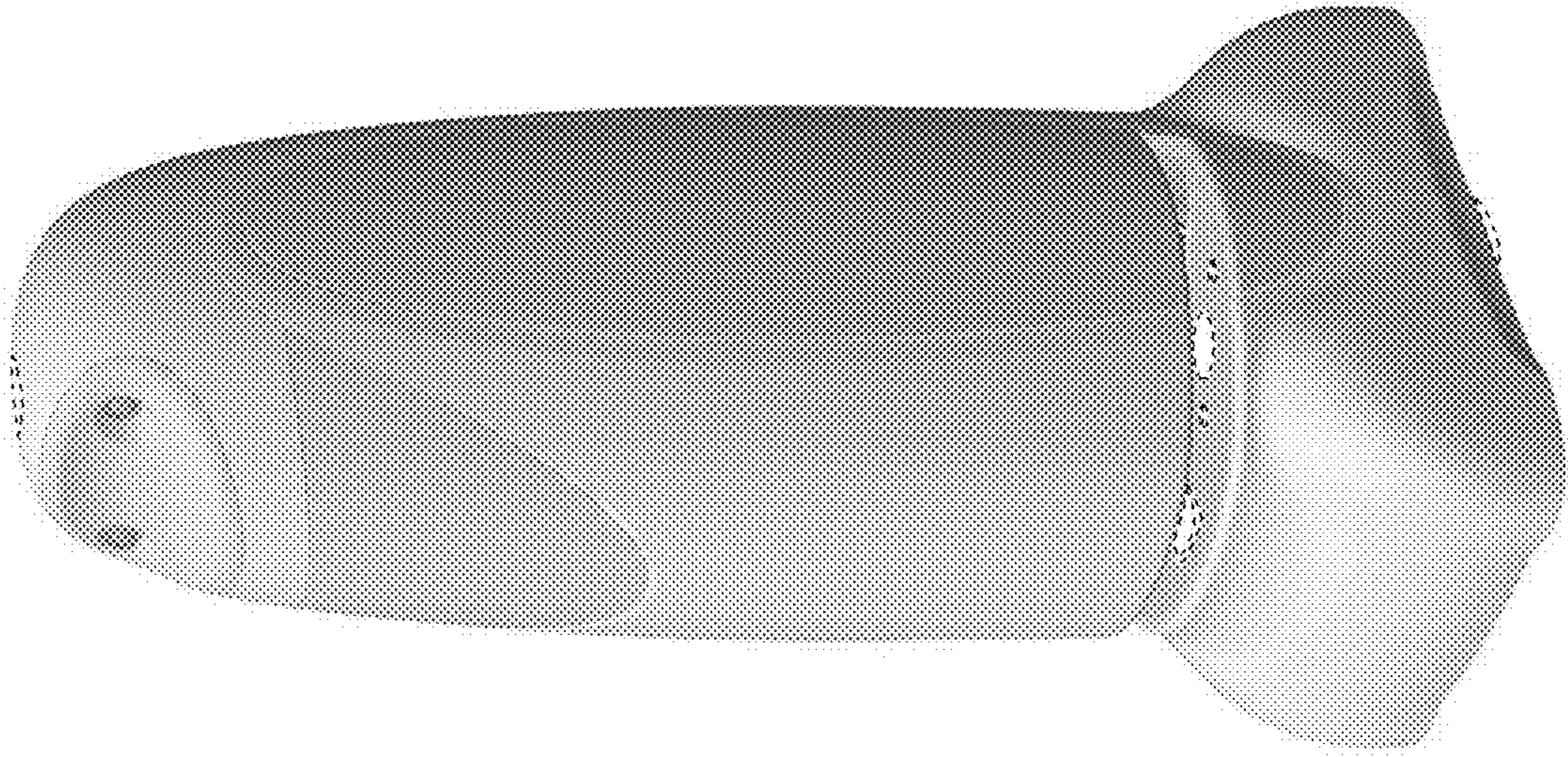

Fig. 1

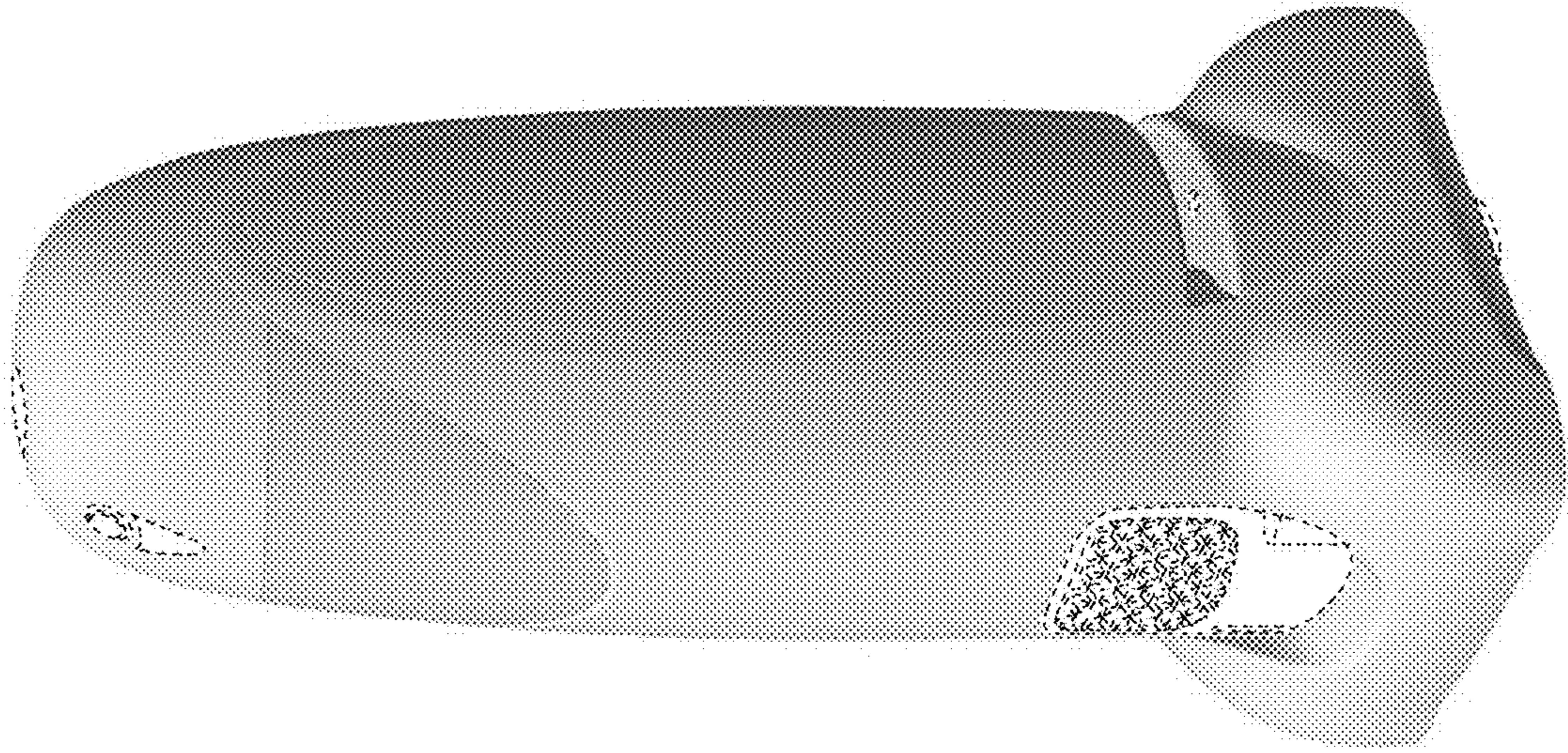

Fig.2

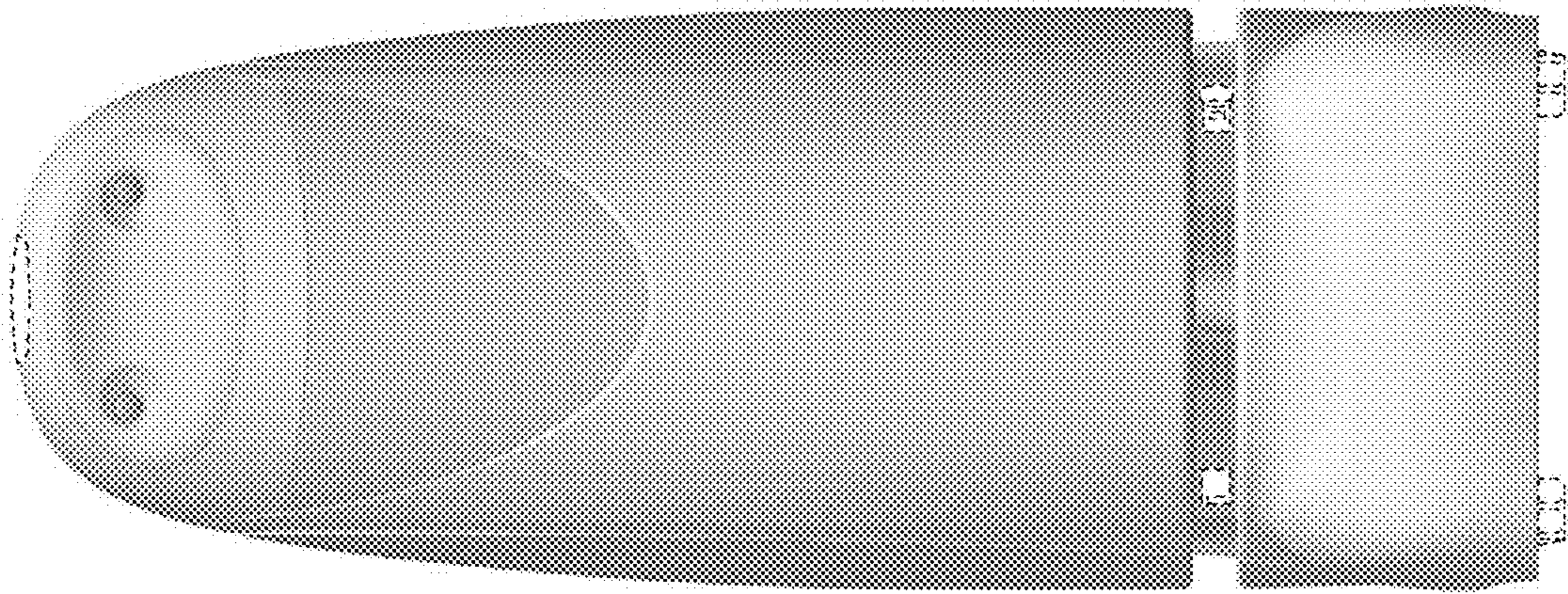

Fig. 3

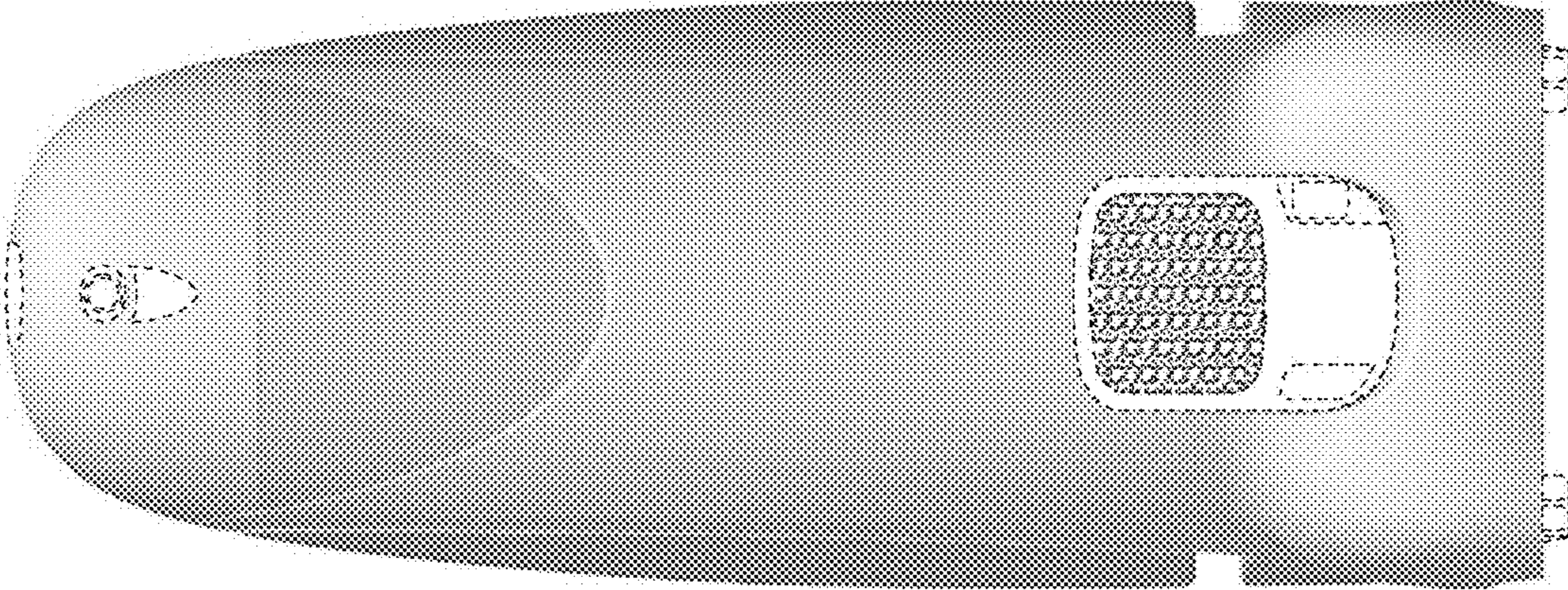

Fig.4

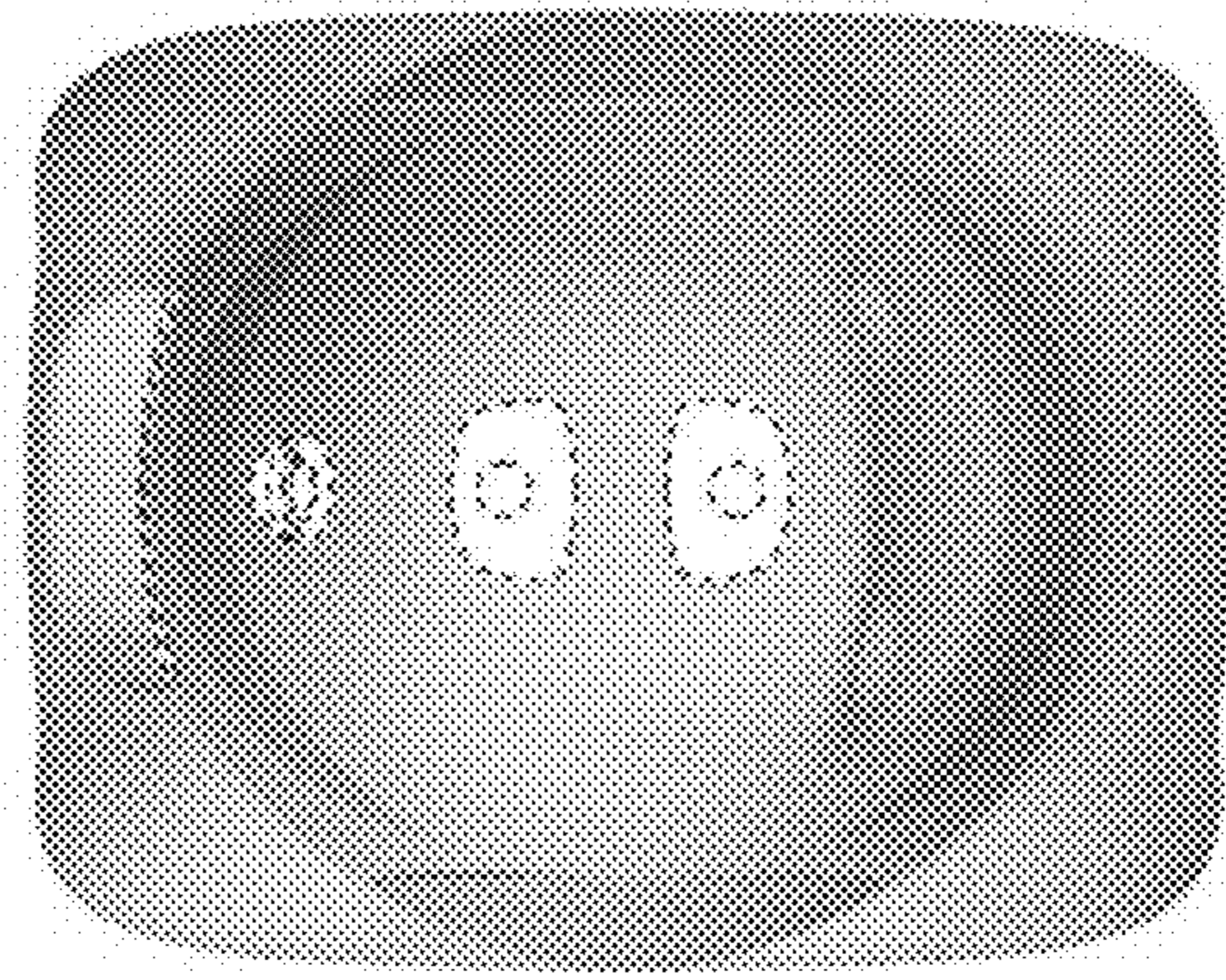

Fig. 5

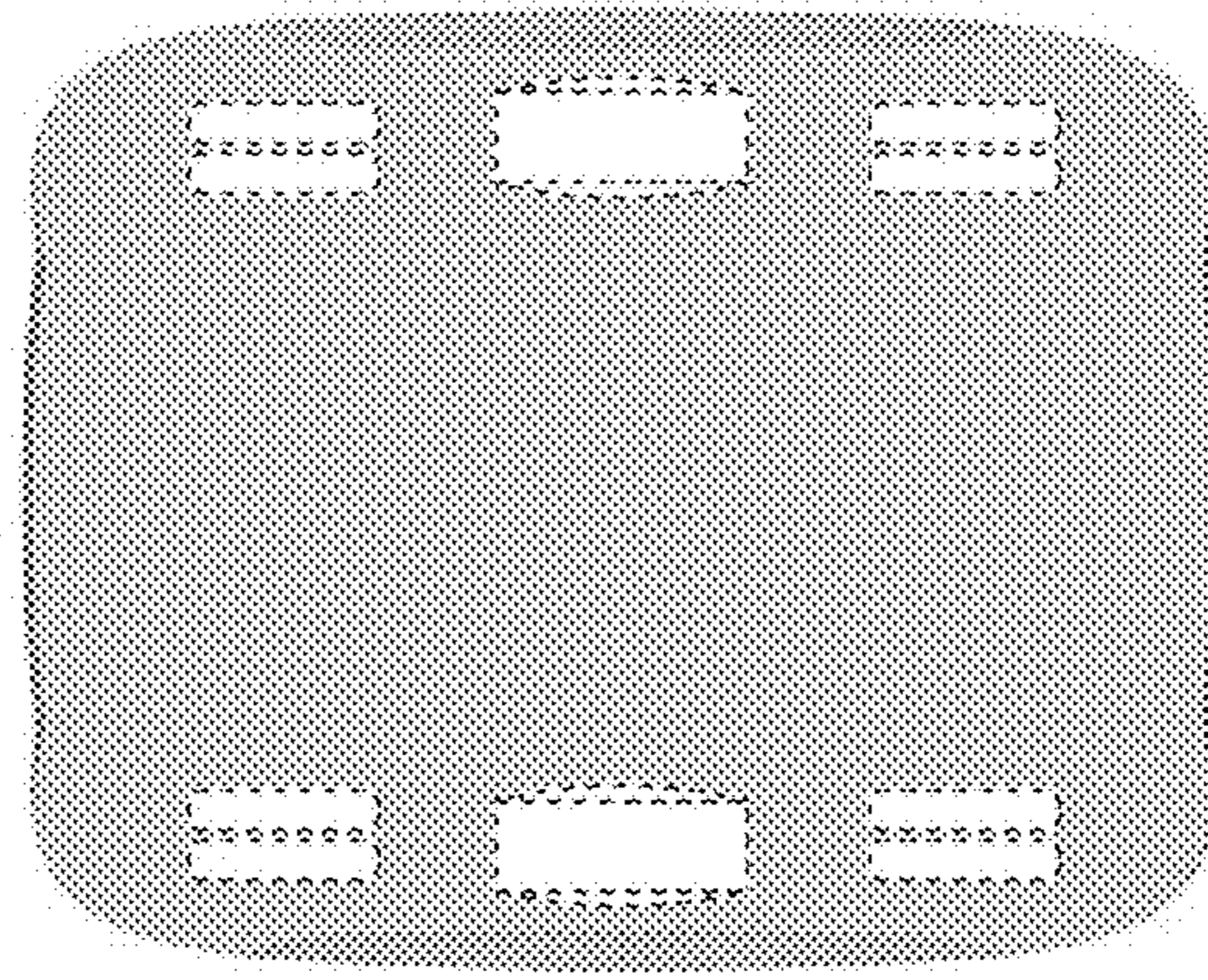

Fig. 6

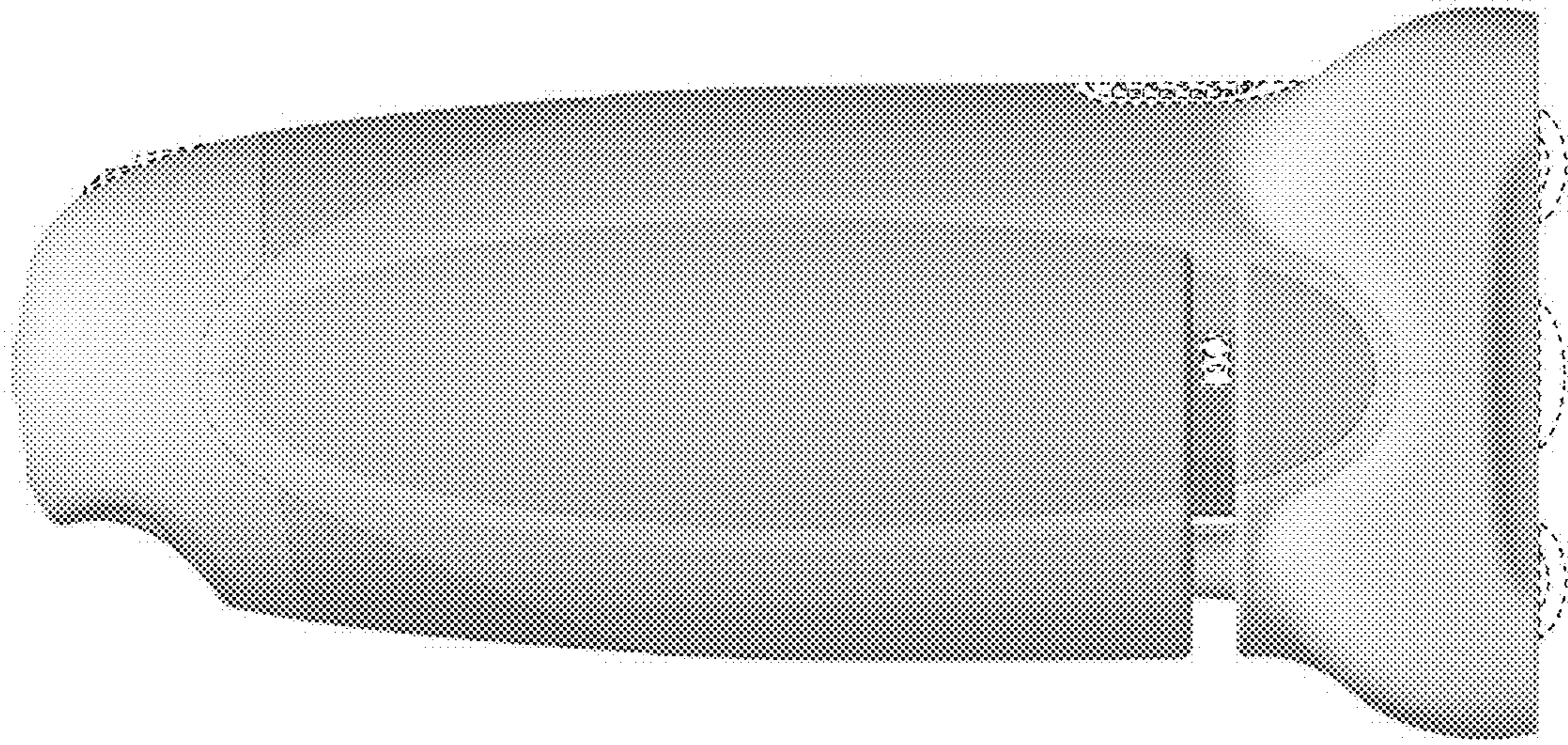

Fig. 7

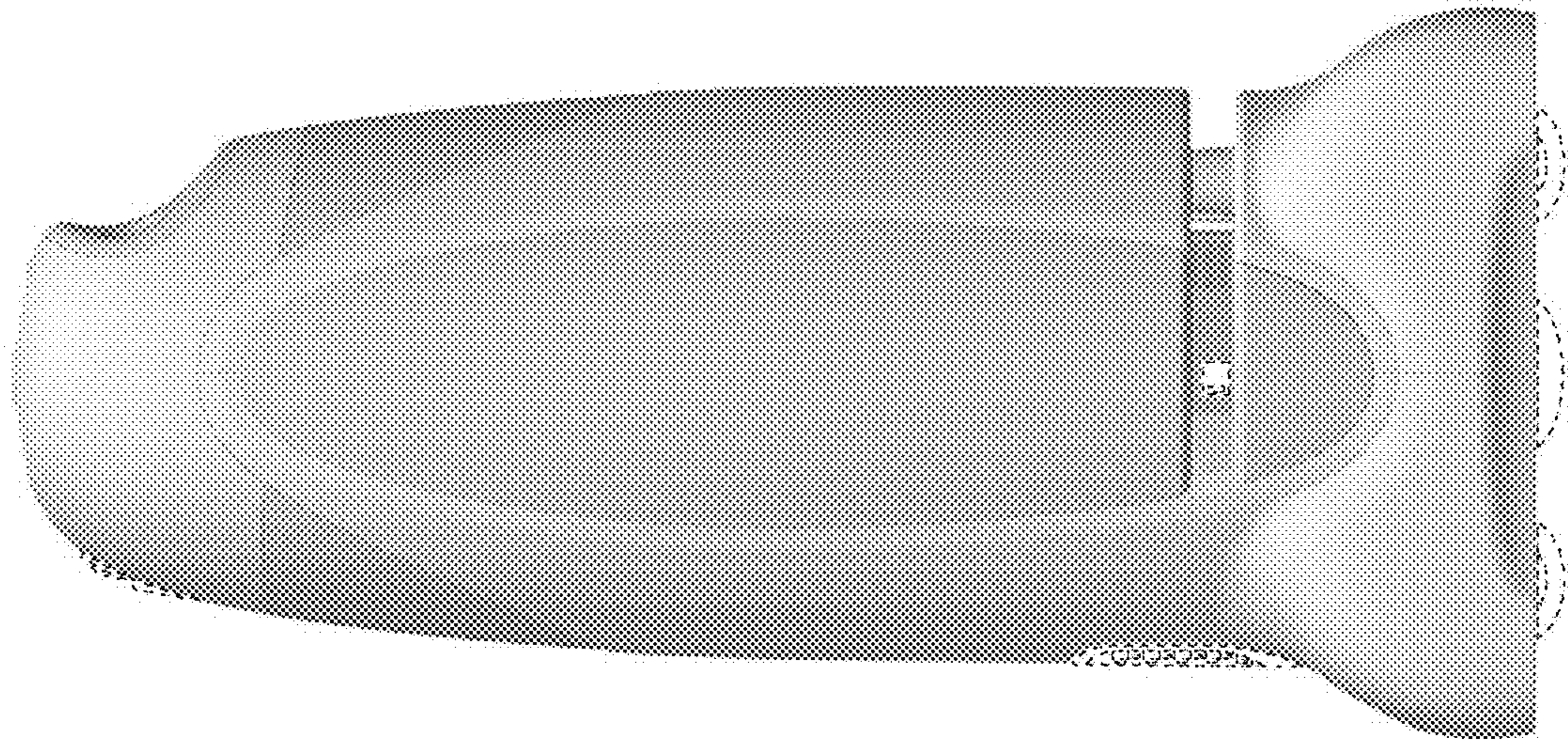

Fig. 8