



US00D941184S

(12) **United States Design Patent**
Kim et al.

(10) **Patent No.:** **US D941,184 S**
(45) **Date of Patent:** **** Jan. 18, 2022**

(54) **VEHICLE BODY**

(71) Applicant: **Canoo Technologies Inc.**, Torrance, CA (US)

(72) Inventors: **Richard Kim**, Los Angeles, CA (US); **Brian Oh**, Rancho Palos Verdes, CA (US); **Jackson E. Luttig**, Rancho Palos Verdes, CA (US); **Noah Hammersten**, Studio City, CA (US); **Brian E. Spencer**, Lakewood, CA (US); **Hanna Kim**, San Pedro, CA (US)

(73) Assignee: **Canoo Technologies Inc.**, Torrance, CA (US)

(**) Term: **15 Years**

(21) Appl. No.: **29/742,026**

(22) Filed: **Sep. 24, 2019**

(51) **LOC (13) Cl.** **12-08**

(52) **U.S. Cl.**
USPC **D12/86**

(58) **Field of Classification Search**
USPC D12/1, 14, 82, 86, 93–100; D21/533, D21/552–560
CPC B60F 3/0061; B62D 35/00; B62D 33/00; B62D 25/00; B62D 25/06; B62D 33/06; B62D 33/0607; B62D 33/0621; B62D 33/0625; B62D 39/00; B62D 49/005; B62D 49/007
See application file for complete search history.

(56) **References Cited**

U.S. PATENT DOCUMENTS

D238,799 S * 2/1976 Goldfarb D21/556
D262,391 S * 12/1981 Kanaoki D21/450
D274,637 S * 7/1984 Terui D21/552
D457,467 S * 5/2002 Shimizu D12/86
D800,017 S * 10/2017 Sapet D12/86

D832,742 S * 11/2018 Fisker D12/86
D839,784 S * 2/2019 Sugawara D12/86
D860,862 S * 9/2019 Janin D12/90
D875,185 S * 2/2020 Zeng D21/552
10,769,940 B2 * 9/2020 Hur B60W 30/18109

(Continued)

OTHER PUBLICATIONS

Electric Vehicle. (Design—© Questel) orbit.com. [Online PDF compilation of references selected by examiner] 49 pgs. Print Dates Range Jan. 20, 2021–Mar. 28, 2019 [Retrieved Jun. 29, 2021].*

(Continued)

Primary Examiner — Manpreet S Matharu
Assistant Examiner — Suzanne E Tisdell

(57) **CLAIM**

The ornamental design for a vehicle body, as shown and described.

DESCRIPTION

FIG. 1 is a perspective view of a vehicle body, according to a first embodiment of the invention.
FIG. 2 is a front view thereof.
FIG. 3 is a rear view thereof.
FIG. 4 is left side view thereof.
FIG. 5 is a right side view thereof.
FIG. 6 is a top view thereof.
FIG. 7 is a perspective view of a vehicle body, according to a second embodiment of the invention.
FIG. 8 is a front view thereof.
FIG. 9 is a rear view thereof.
FIG. 10 is left side view thereof.
FIG. 11 is a right side view thereof; and,
FIG. 12 is a top view thereof.
Mirror images of opposite side views are within the scope of the claimed design even if not illustrated.
Features shown in broken lines do not form part of the claimed design.

1 Claim, 12 Drawing Sheets

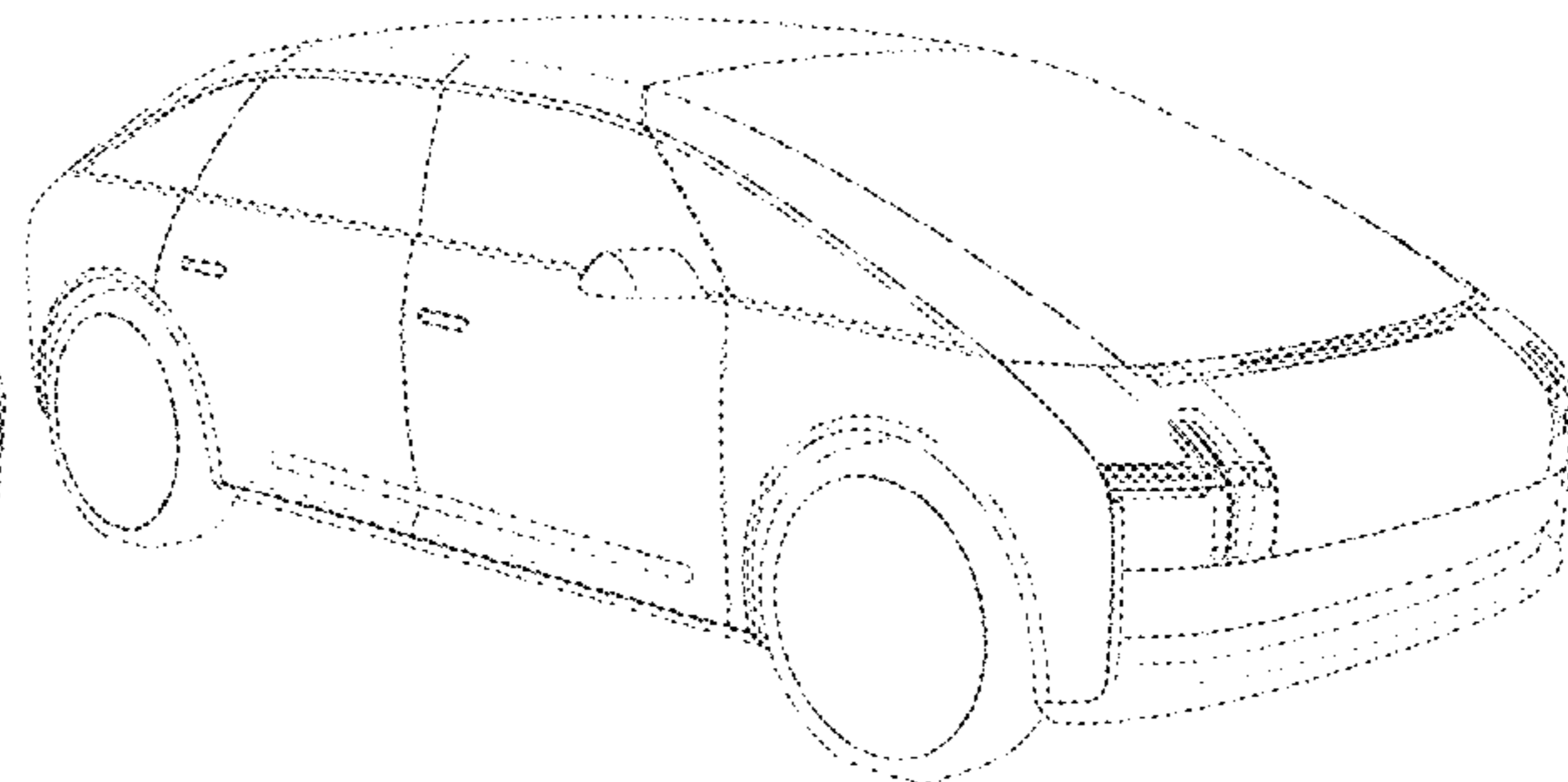
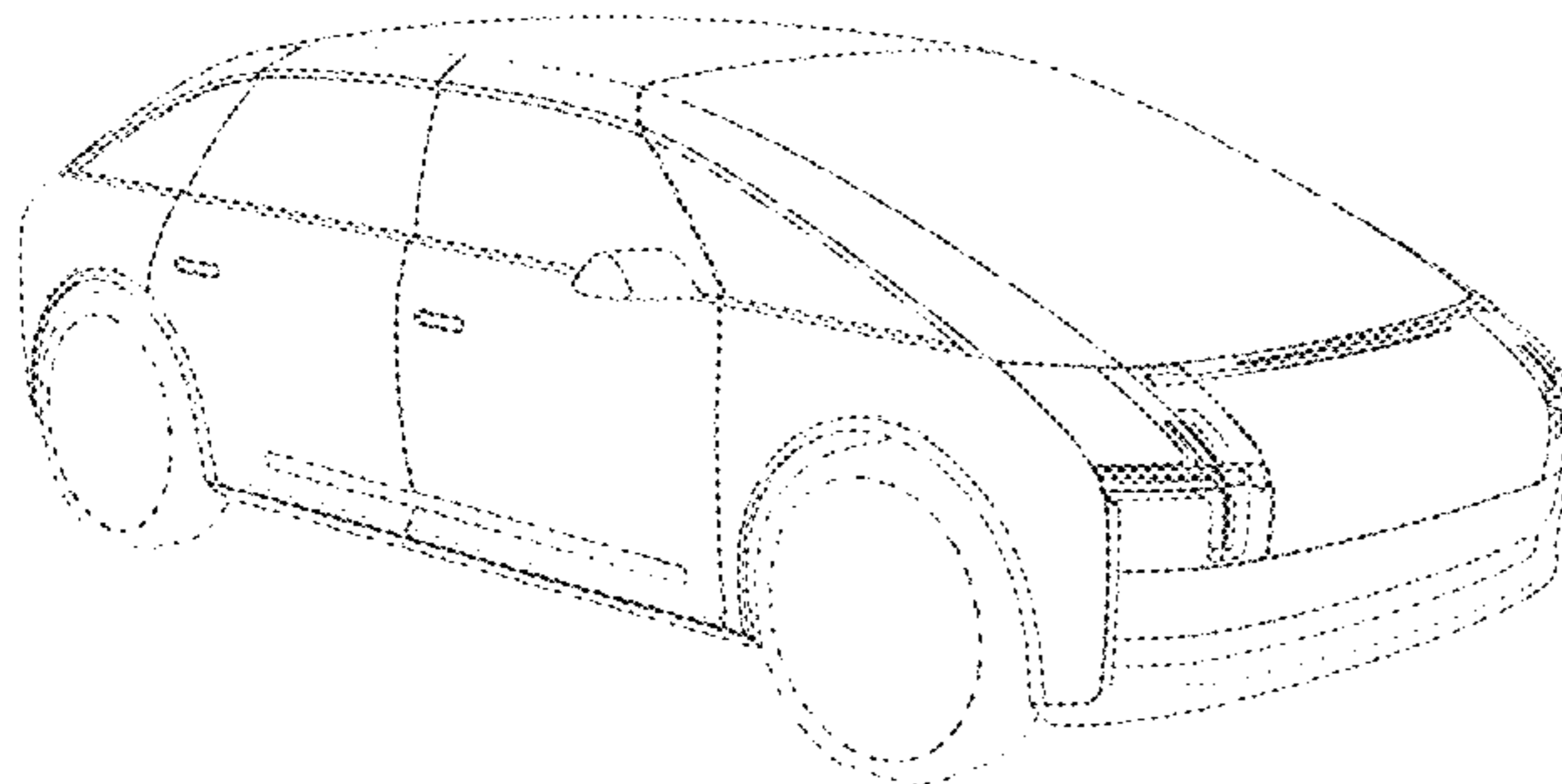

(56)

References Cited

U.S. PATENT DOCUMENTS

10,821,776 B1 * 11/2020 Labadie B60B 3/10
10,829,145 B2 * 11/2020 Washnock F16H 19/04
10,870,361 B2 * 12/2020 Hara H01M 8/04201
10,951,044 B2 * 3/2021 Choi H02J 7/0013
10,959,892 B2 * 3/2021 Yamada A61G 5/04
10,974,582 B2 * 4/2021 Hara B60K 1/04
10,983,199 B2 * 4/2021 Adams G01S 7/4972
11,034,254 B2 * 6/2021 Booth H02J 7/0027
11,040,609 B2 * 6/2021 Hara G05D 1/021

OTHER PUBLICATIONS

Reynolds, Kim. "The Canoo Electric Car: 6 Thoughts After Visiting the EV Startup." Aug. 17, 2019. Motor Trend, <https://www.motortrend.com/news/canoo-electric-car-6-thoughts-ev-startup/>.*

Abuelsamid, Sam. "Introducing Canoo, No Paddles Required for This Electric Van." Sep. 24, 2019. Forbes, <https://www.forbes.com/sites/samabuelsamid/2019/09/24/introducing-canoo-no-paddles-required-for-this-electric-van/?sh=3a231b27641d>.*

O'Kane, Sean. "Canoo's First Subscription—Only EV is a Refreshing Rethink of the VW Microbus." Sep. 24, 2019. The Verge, <https://www.theverge.com/2019/9/24/20882538/canoo-evelozcity-ev-subscription-electric-vehicle>.*

* cited by examiner

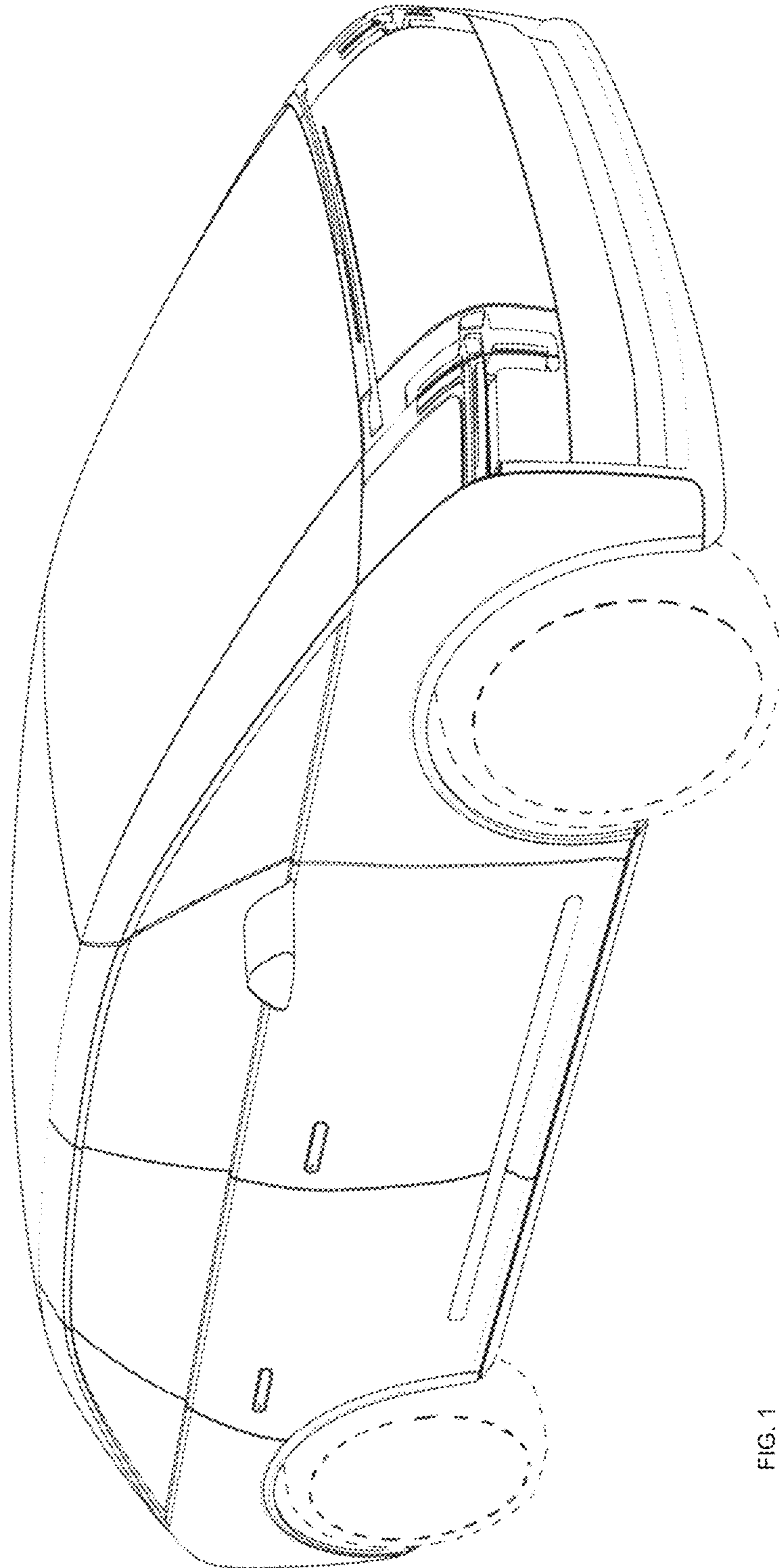

FIG. 1

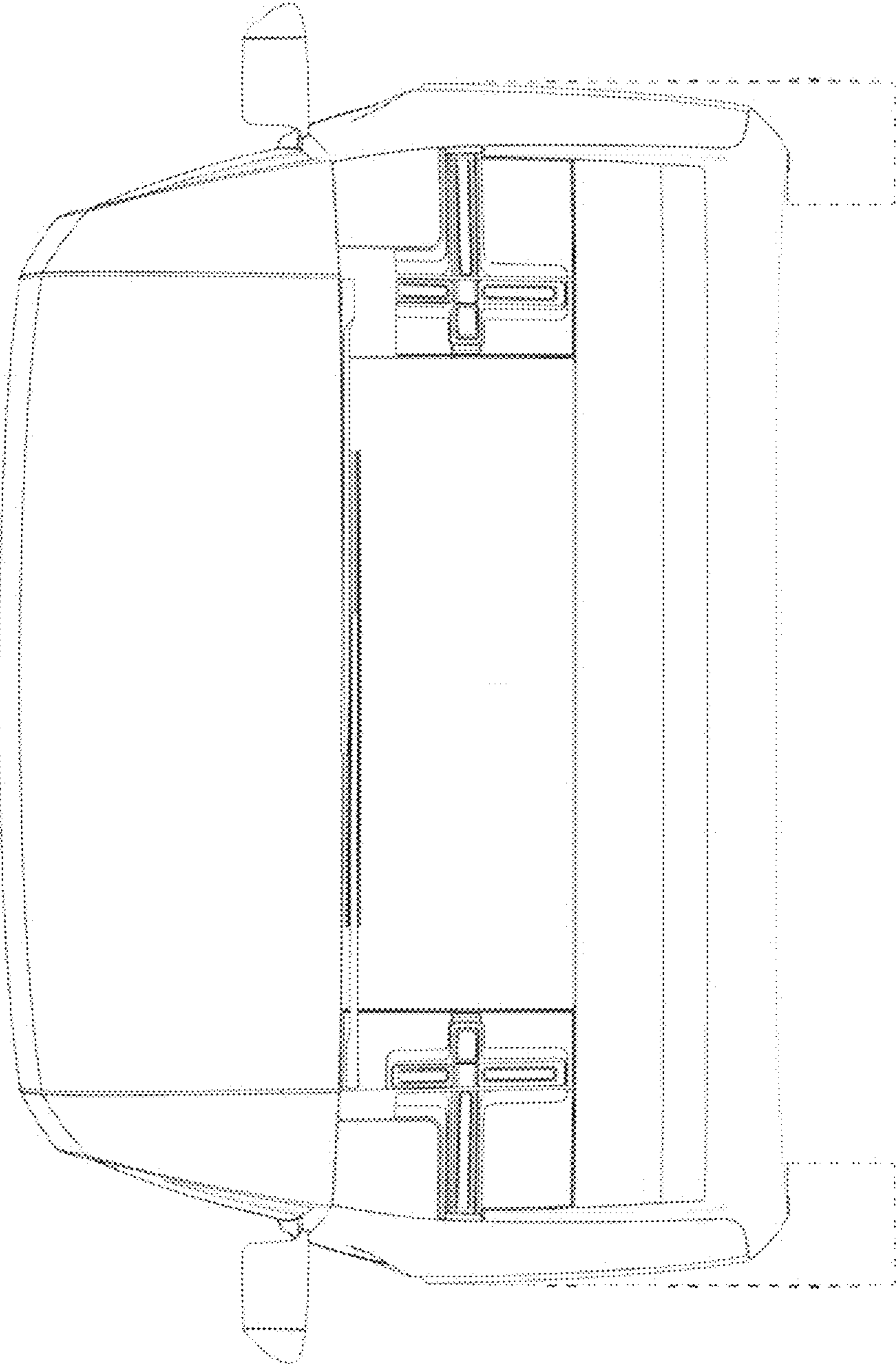

FIG. 2

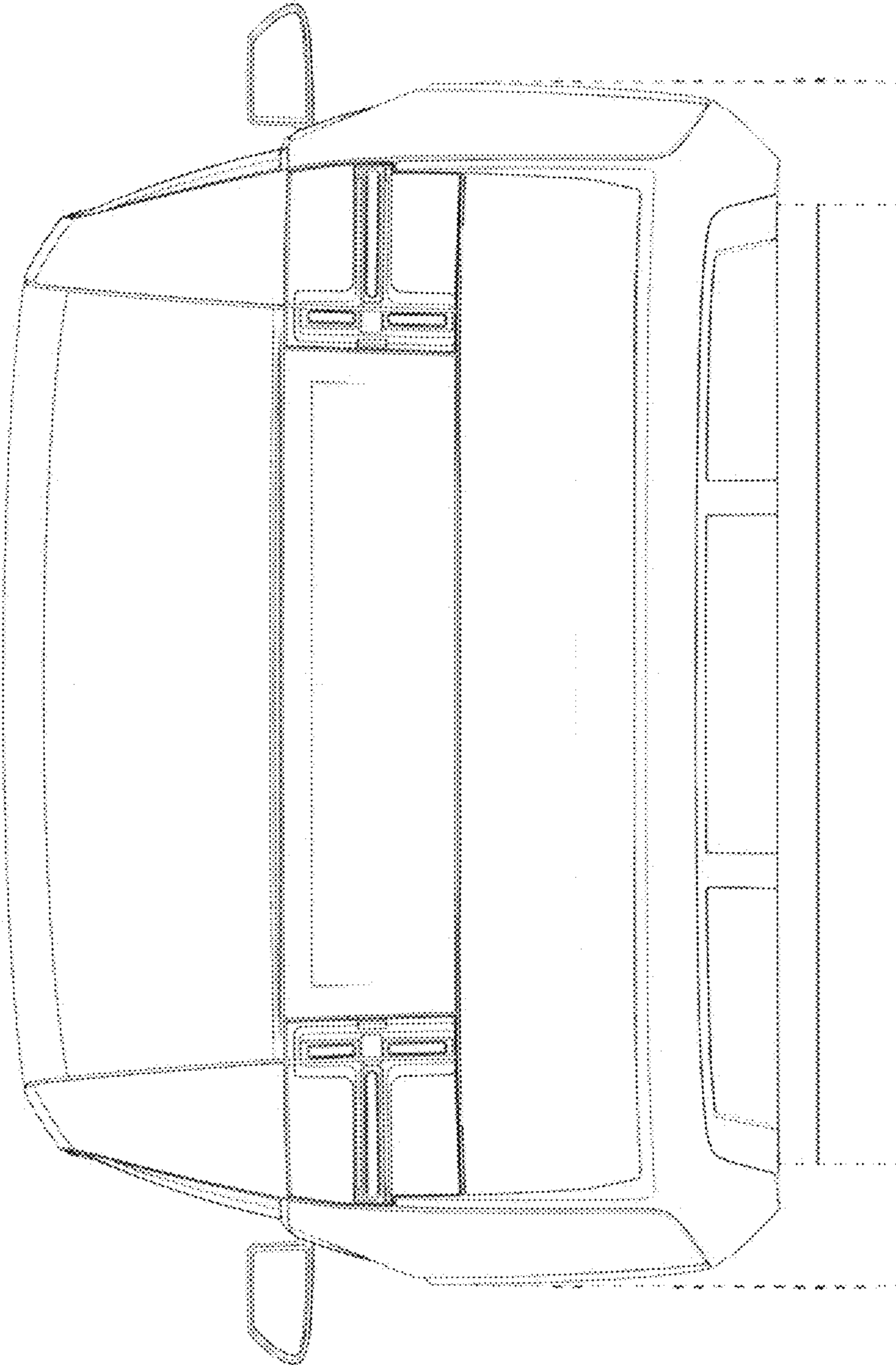

FIG. 3

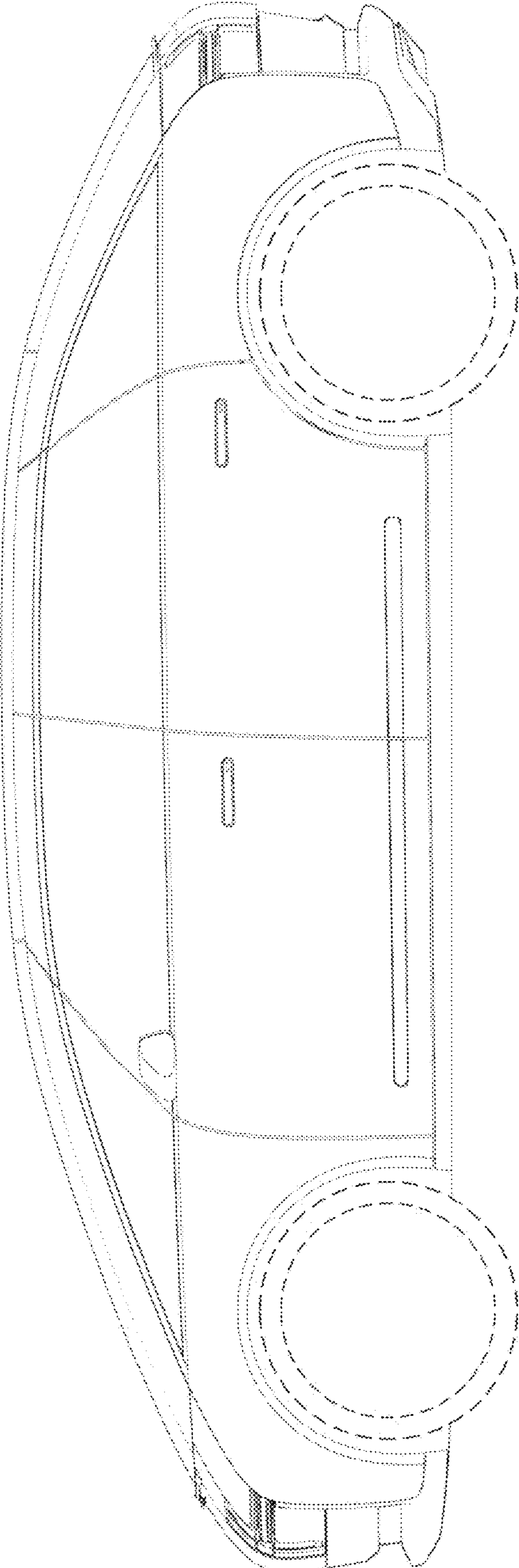

FIG. 4

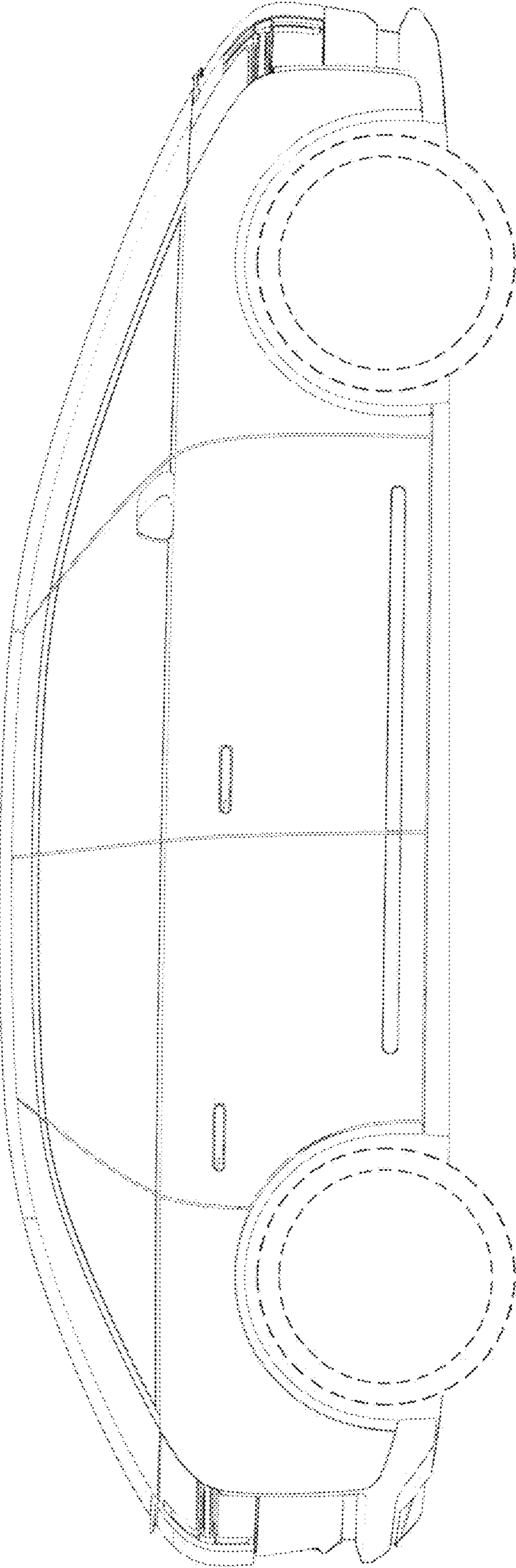

FIG. 5

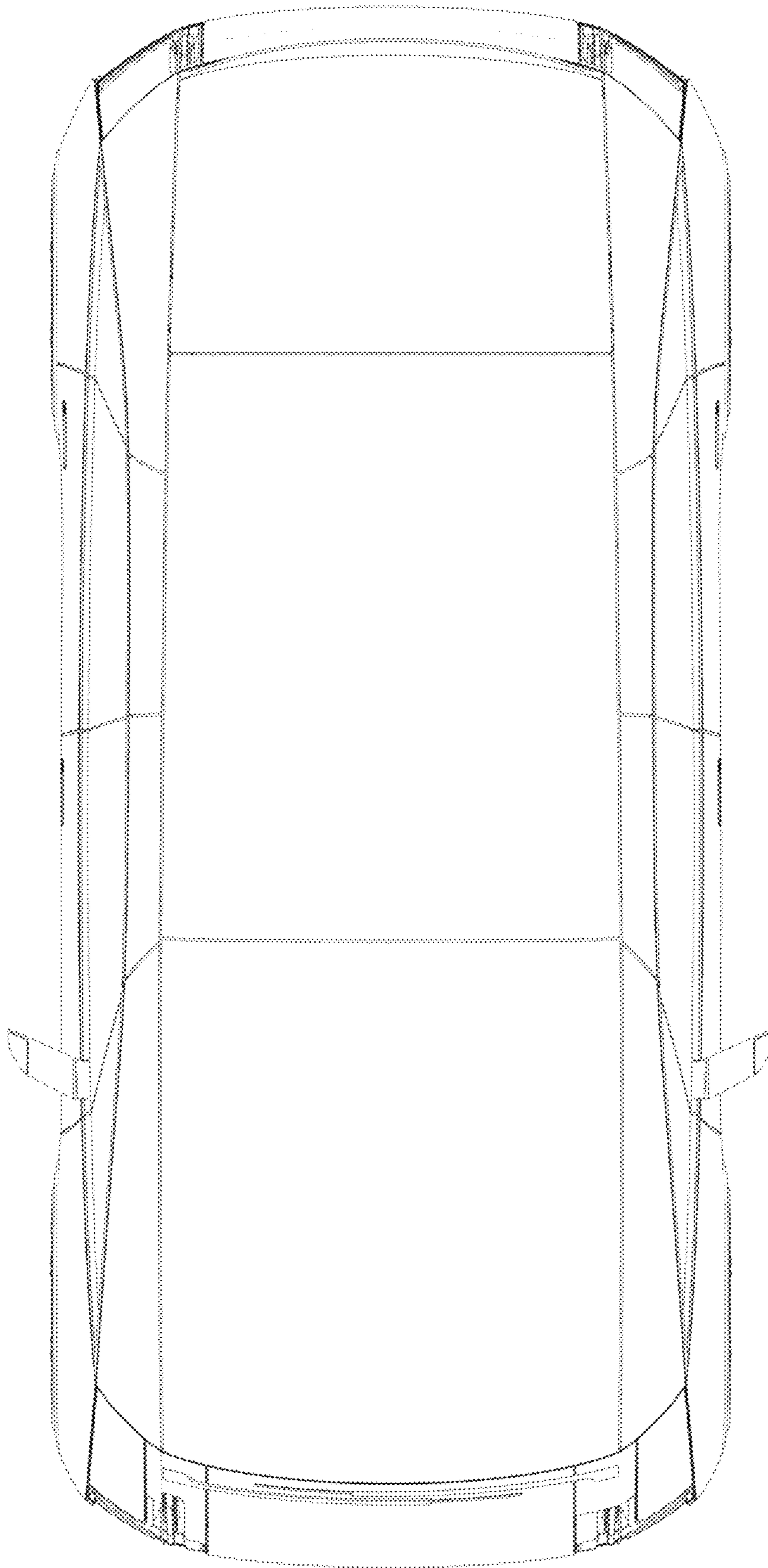

FIG. 6

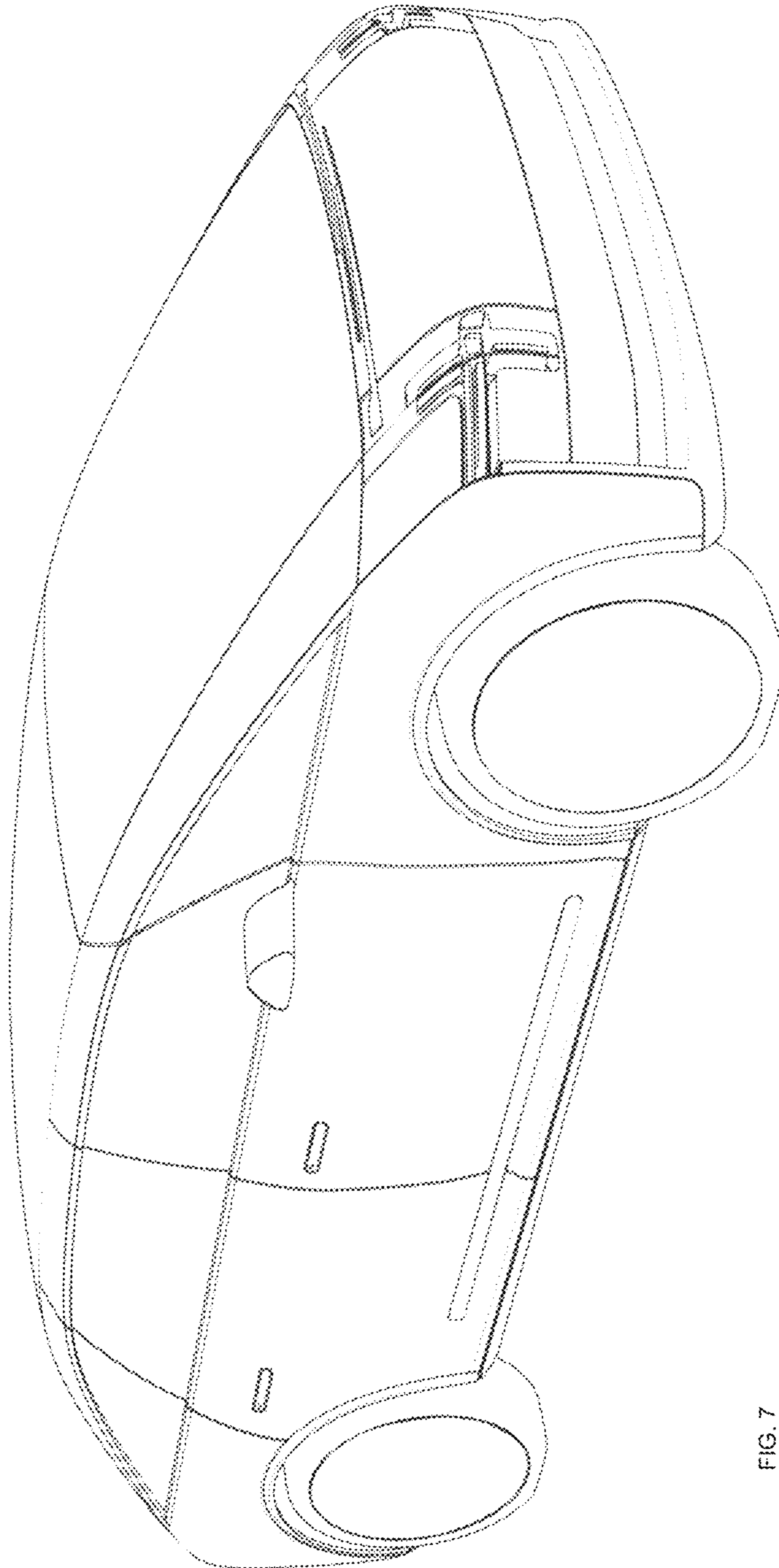

FIG. 7

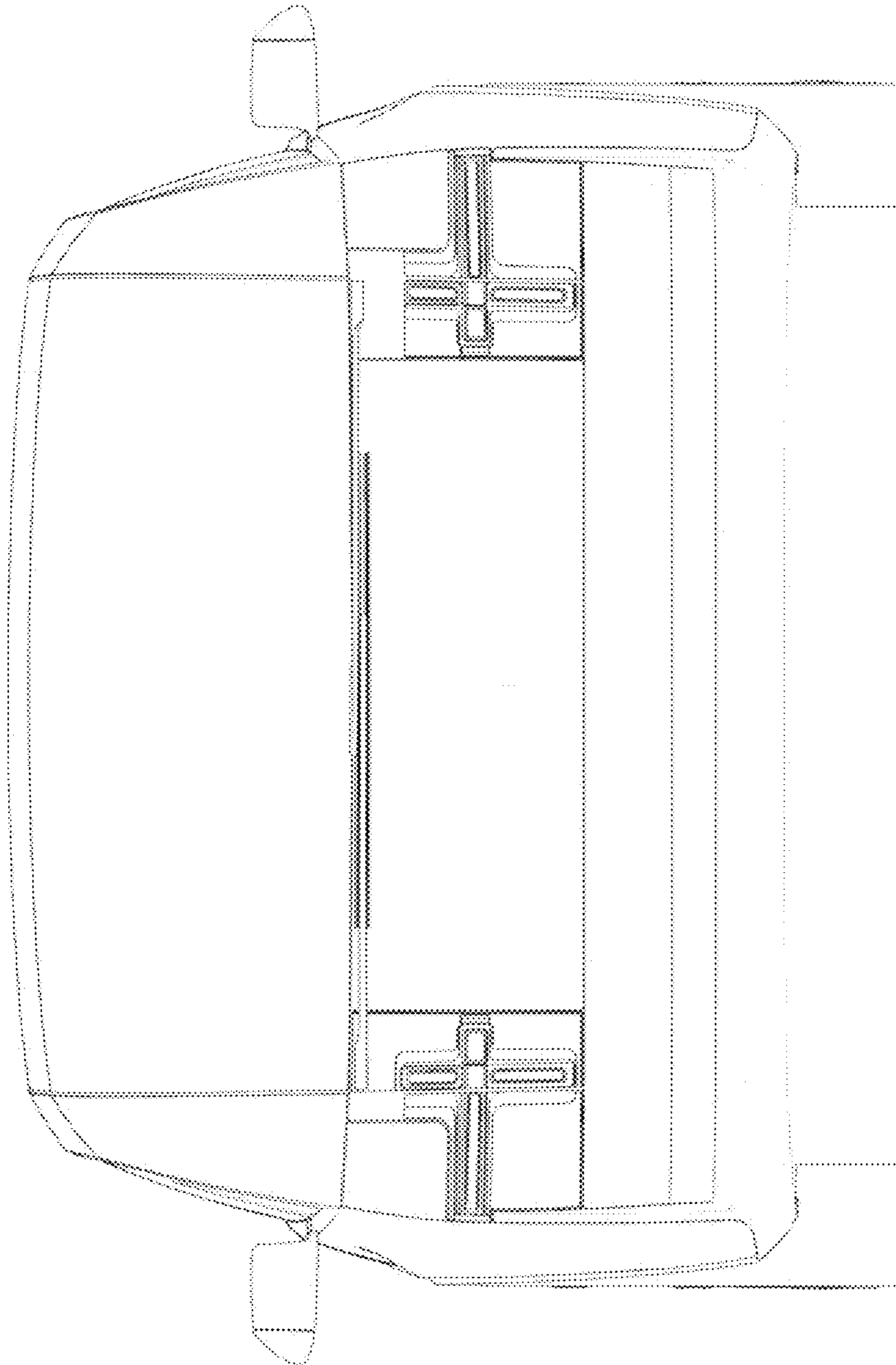

FIG. 8

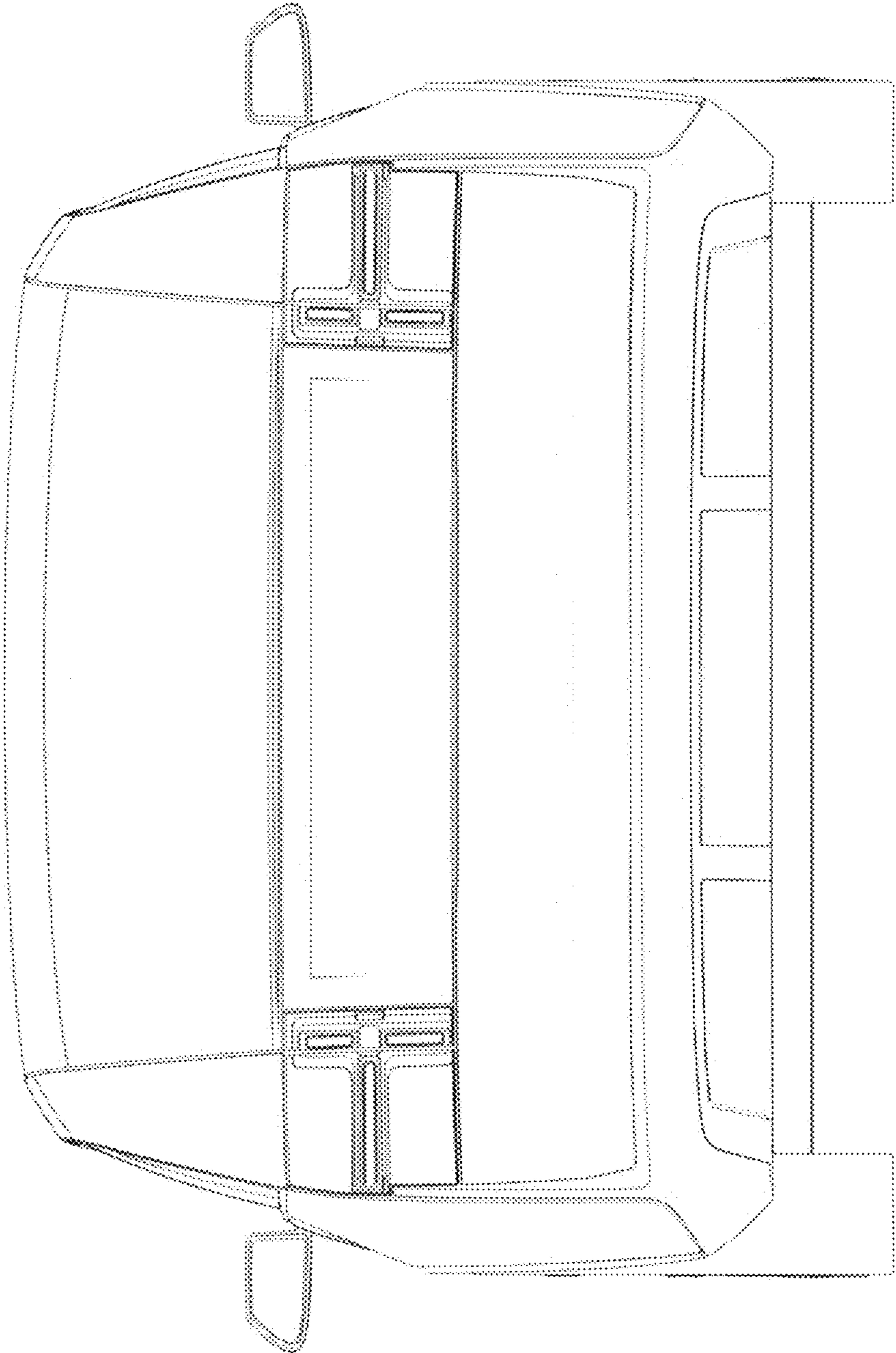

FIG. 9

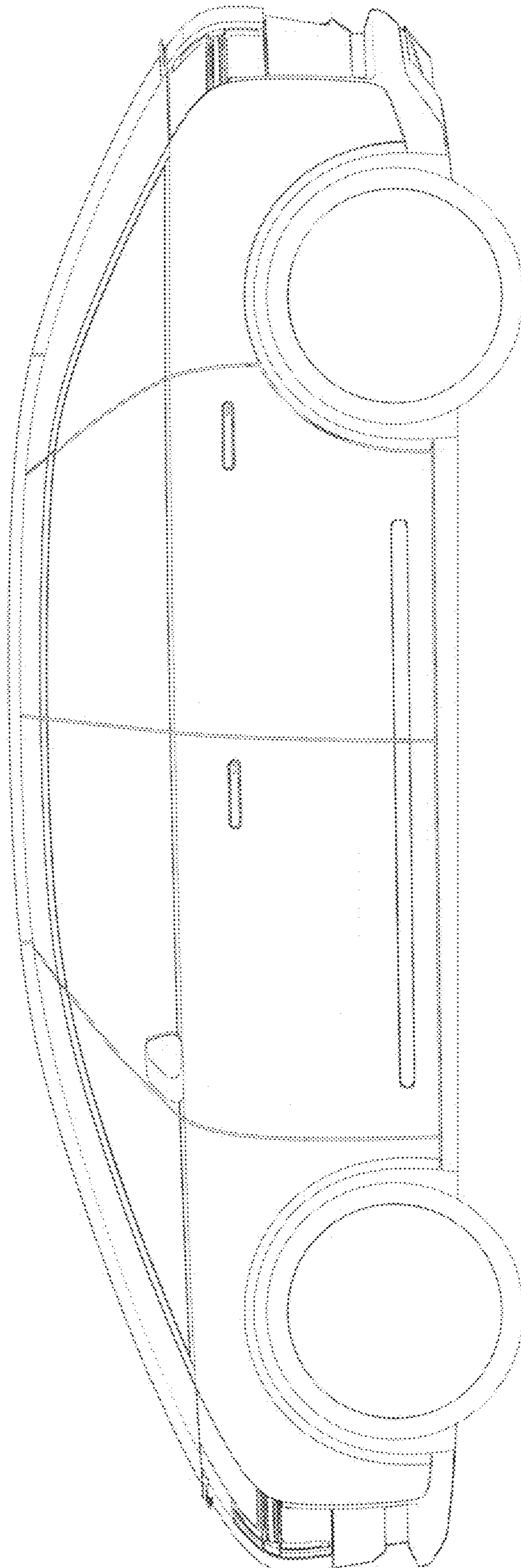

FIG. 10

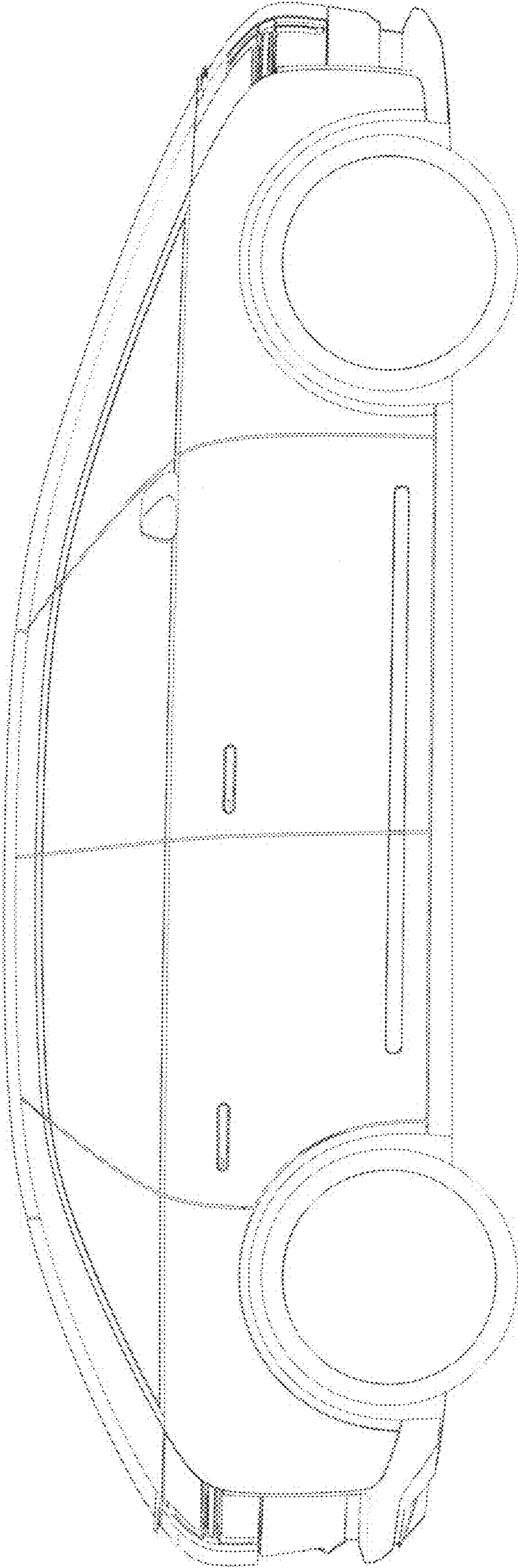

FIG. 11

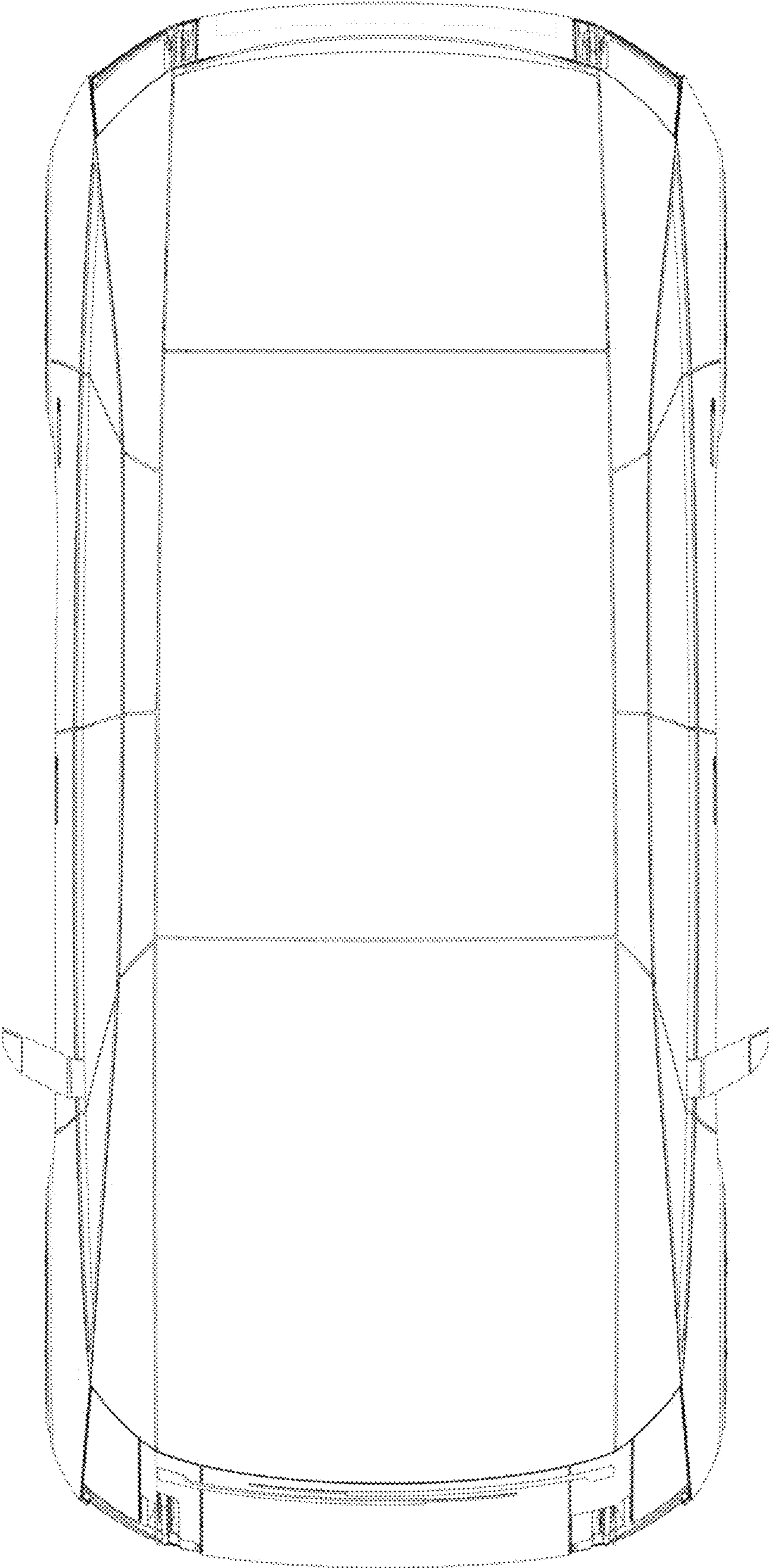

FIG. 12