



US00D940769S

(12) **United States Design Patent**
Saiwai et al.

(10) **Patent No.:** **US D940,769 S**
(45) **Date of Patent:** **** Jan. 11, 2022**

(54) **THERMAL CONDUCTION METAL MATERIAL**

(71) Applicant: **MITSUBISHI MATERIALS CORPORATION**, Tokyo (JP)

(72) Inventors: **Toshihiko Saiwai**, Kitamoto (JP);
Fumio Sakamoto, Kitamoto (JP)

(73) Assignee: **MITSUBISHI MATERIALS CORPORATION**, Tokyo (JP)

(**) Term: **15 Years**

(21) Appl. No.: **29/681,472**

(22) Filed: **Feb. 26, 2019**

(30) **Foreign Application Priority Data**

Sep. 26, 2018 (JP) 2018-020957
Sep. 26, 2018 (JP) 2018-020958
Sep. 26, 2018 (JP) 2018-020959

(51) **LOC (13) Cl.** **15-09**

(52) **U.S. Cl.**
USPC **D15/144**

(58) **Field of Classification Search**
USPC D15/144, 144.1, 144.2; D25/1, 25, 154
CPC B29C 48/08
See application file for complete search history.

(56) **References Cited**

U.S. PATENT DOCUMENTS

D239,827 S * 5/1976 Howells D25/142
D262,154 S * 12/1981 Jury D25/154
D263,881 S * 4/1982 Jury D25/153
D263,887 S * 4/1982 Jury D25/154
D263,888 S * 4/1982 Jury D25/154
D269,349 S * 6/1983 Belter D15/144
D270,353 S * 8/1983 Lewellen D15/144
D282,262 S * 1/1986 Ramazzotti D15/145
D297,387 S * 8/1988 Barr D25/153

4,790,455 A * 12/1988 Dieringer B29B 13/022
126/343.5 R
D398,709 S * 9/1998 Ross D25/140
D426,387 S * 6/2000 Matsumoto D5/2
D488,177 S * 4/2004 Dittmann D15/144
D500,063 S * 12/2004 Jeter D15/144
D521,034 S * 5/2006 Dittmann D15/144
D556,798 S * 12/2007 Franco D15/144

(Continued)

Primary Examiner — Patricia A Palasik

(74) *Attorney, Agent, or Firm* — Locke Lord LLP

(57) **CLAIM**

The ornamental design for a thermal conduction metal material, as shown and described.

DESCRIPTION

FIG. 1 is a perspective view from the top and left side of thermal conduction metal material.
FIG. 2 is a perspective view from the bottom and left side thereof.
FIG. 3 is a perspective view from the top and right side thereof.
FIG. 4 is a top plan view thereof.
FIG. 5 is a bottom plan view thereof.
FIG. 6 is a front elevation view thereof.
FIG. 7 is a rear elevation view thereof.
FIG. 8 is a left side elevation view thereof.
FIG. 9 is a right side elevation view thereof.
FIG. 10 is an enlarged cross-sectional view taken along the line 10-10 in the FIG. 4.
FIG. 11 is an enlarged cross-sectional view taken along the line 11-11 in the FIG. 4.
FIG. 12 is an enlarged cross-sectional view taken along the line 12-12 in the FIG. 4; and,
FIG. 13 is an enlarged cross-sectional view taken along the line 13-13 in the FIG. 4.
The design shown is not to be limited to any particular size and may be scaled larger or smaller.

1 Claim, 13 Drawing Sheets

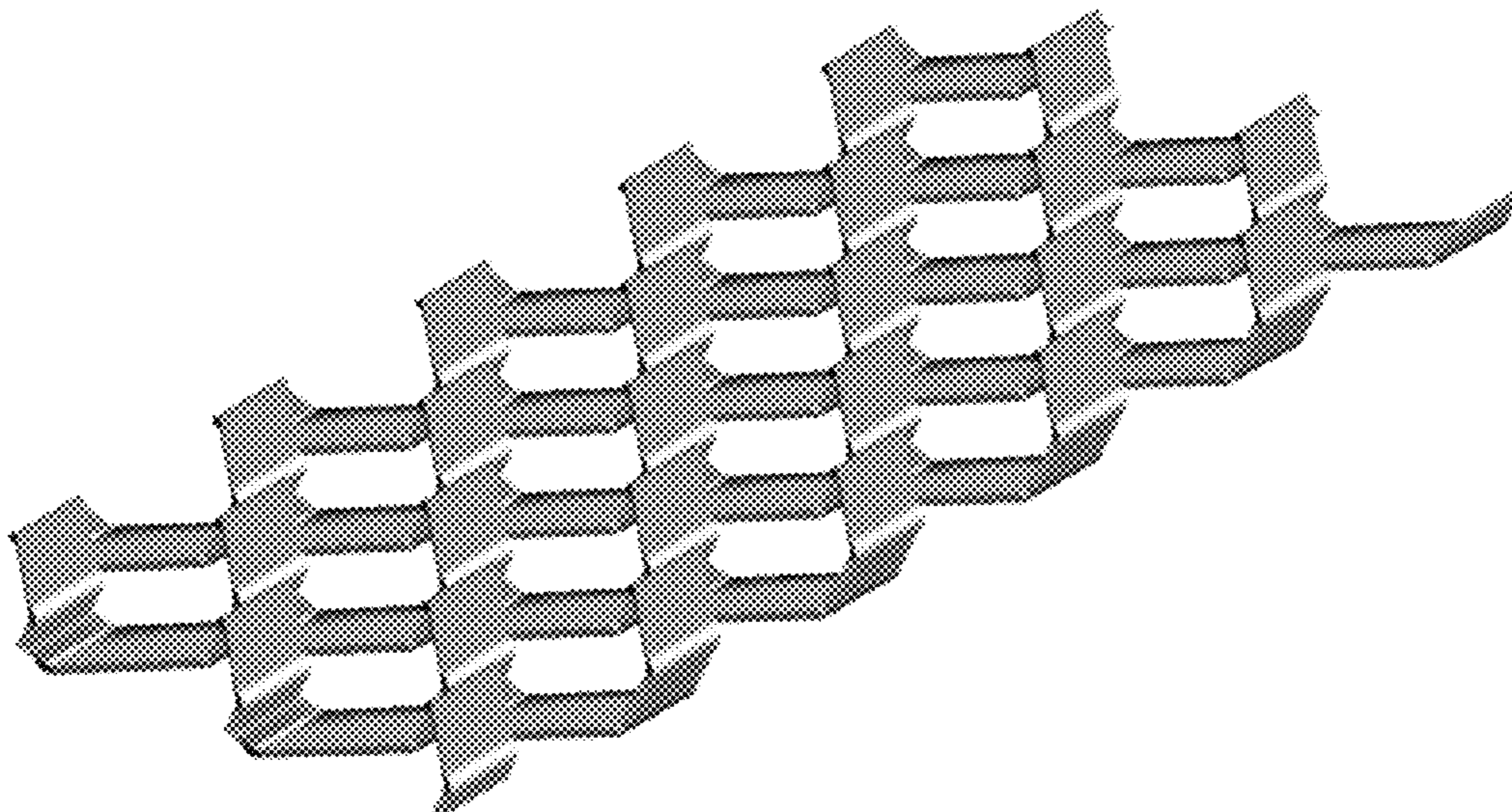

(56)

References Cited

U.S. PATENT DOCUMENTS

D662,325 S * 6/2012 Wong D5/47
10,746,948 B1 * 8/2020 Huang G02B 6/4271

* cited by examiner

FIG. 1

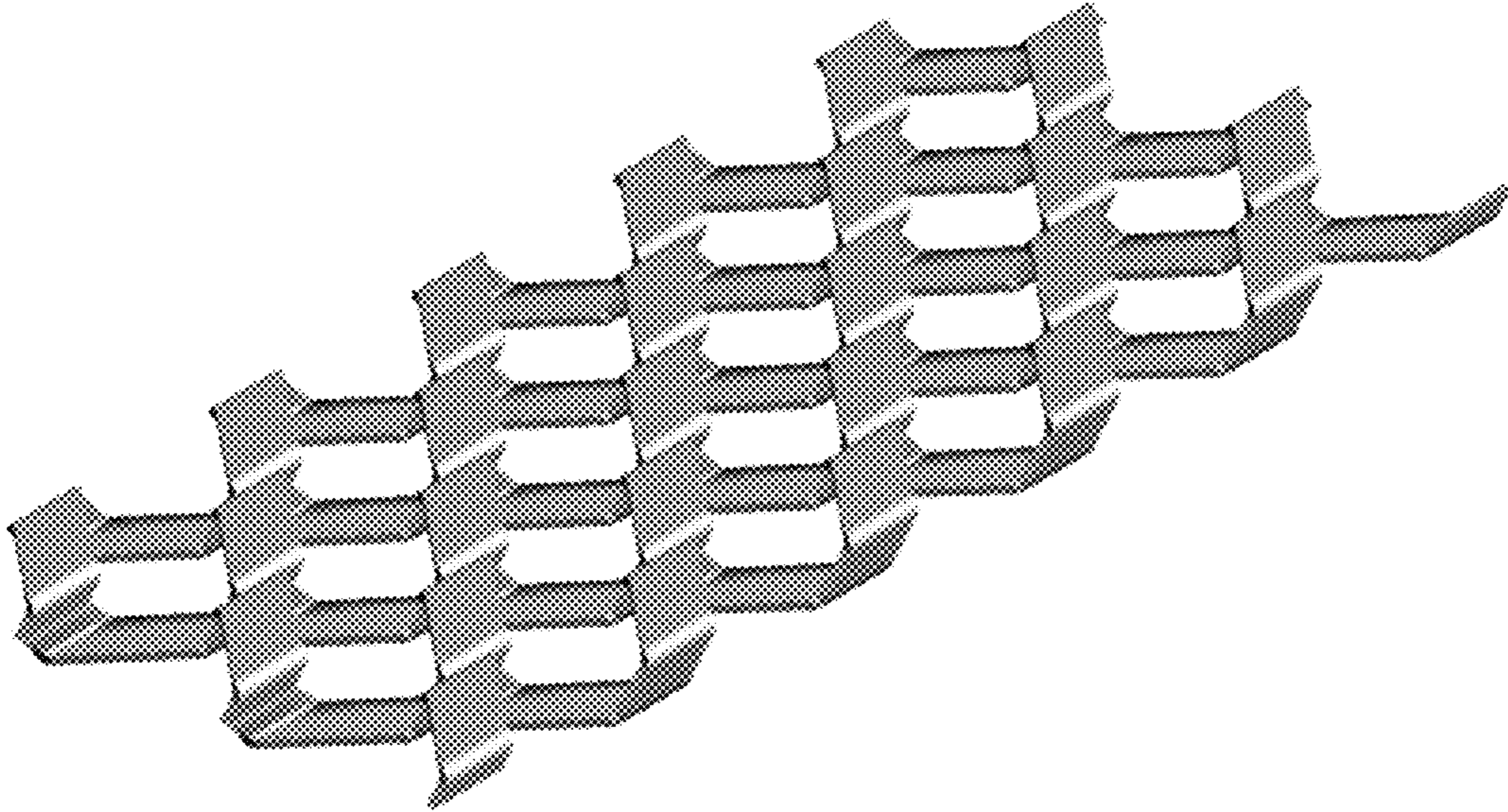

FIG. 2

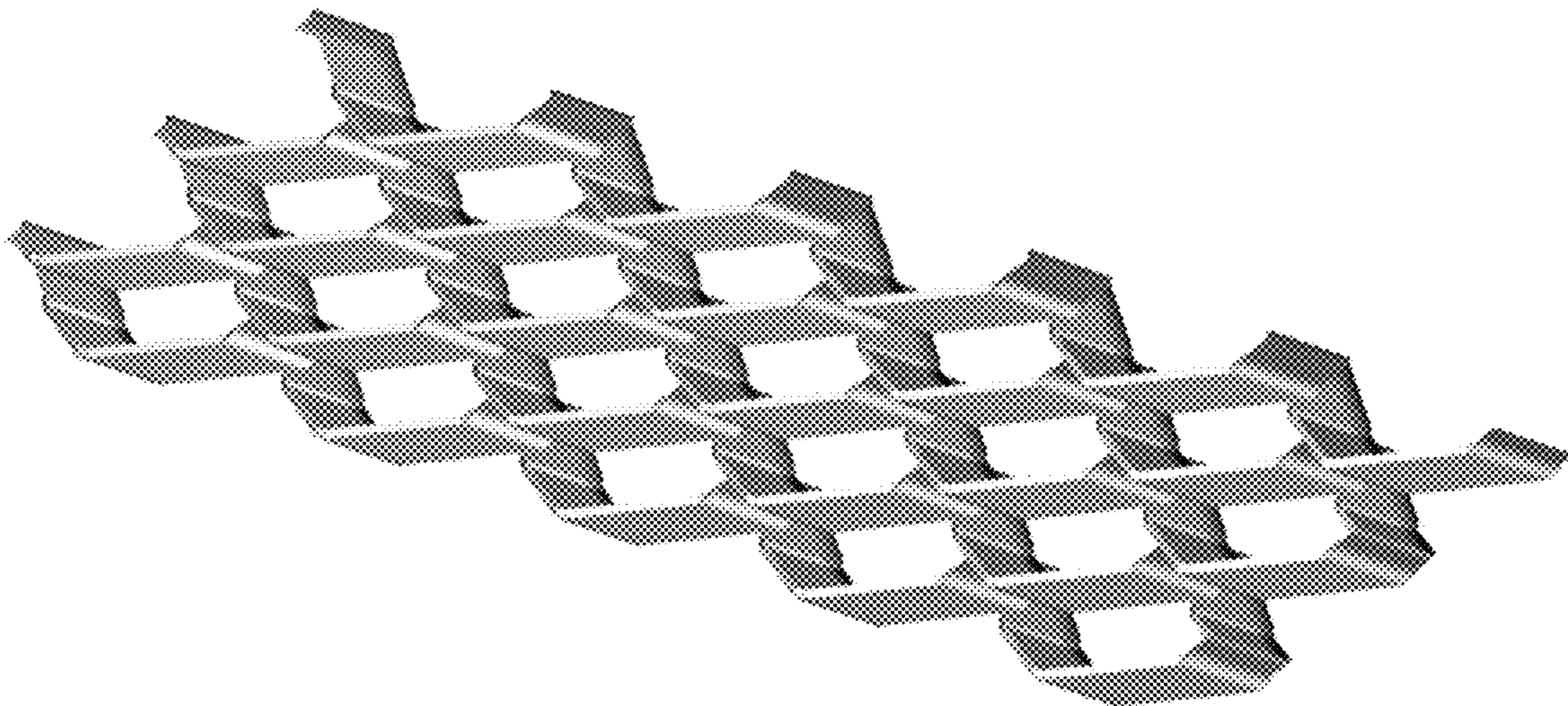

FIG. 3

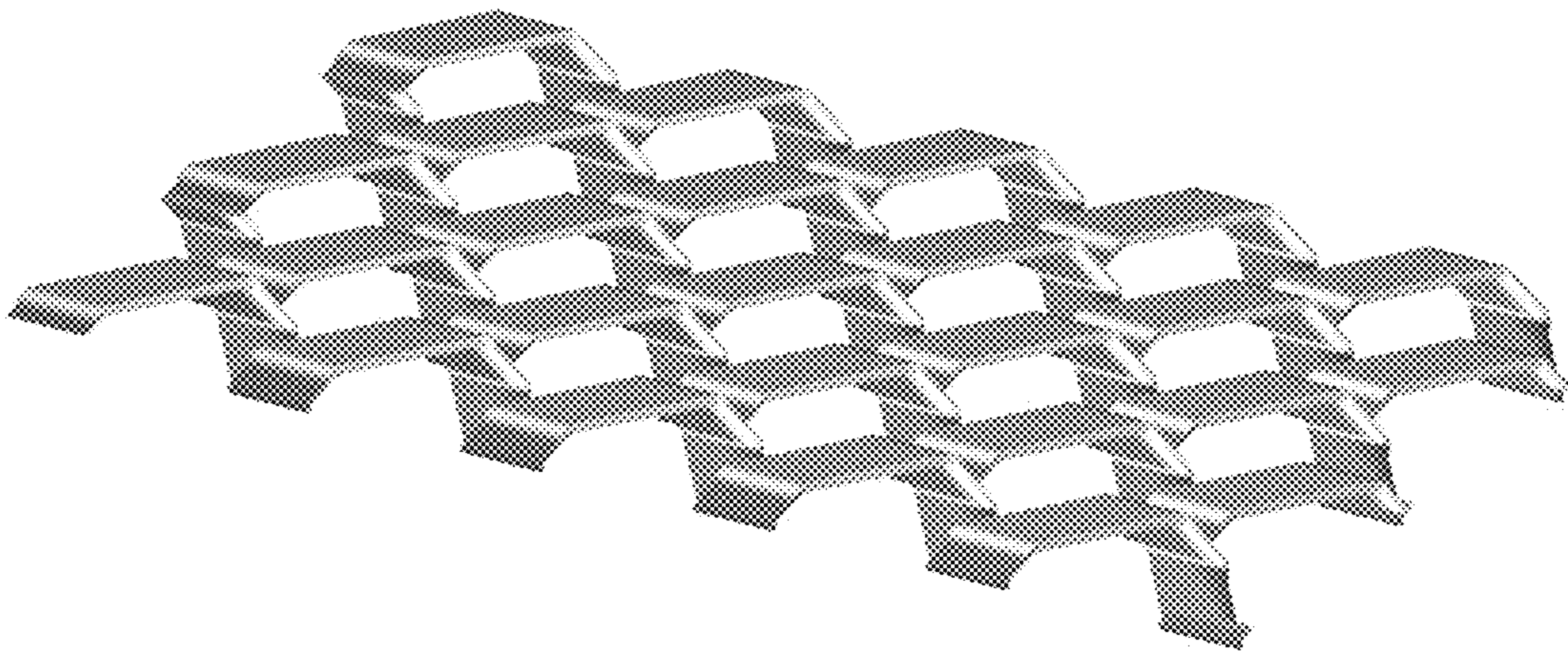

FIG. 4

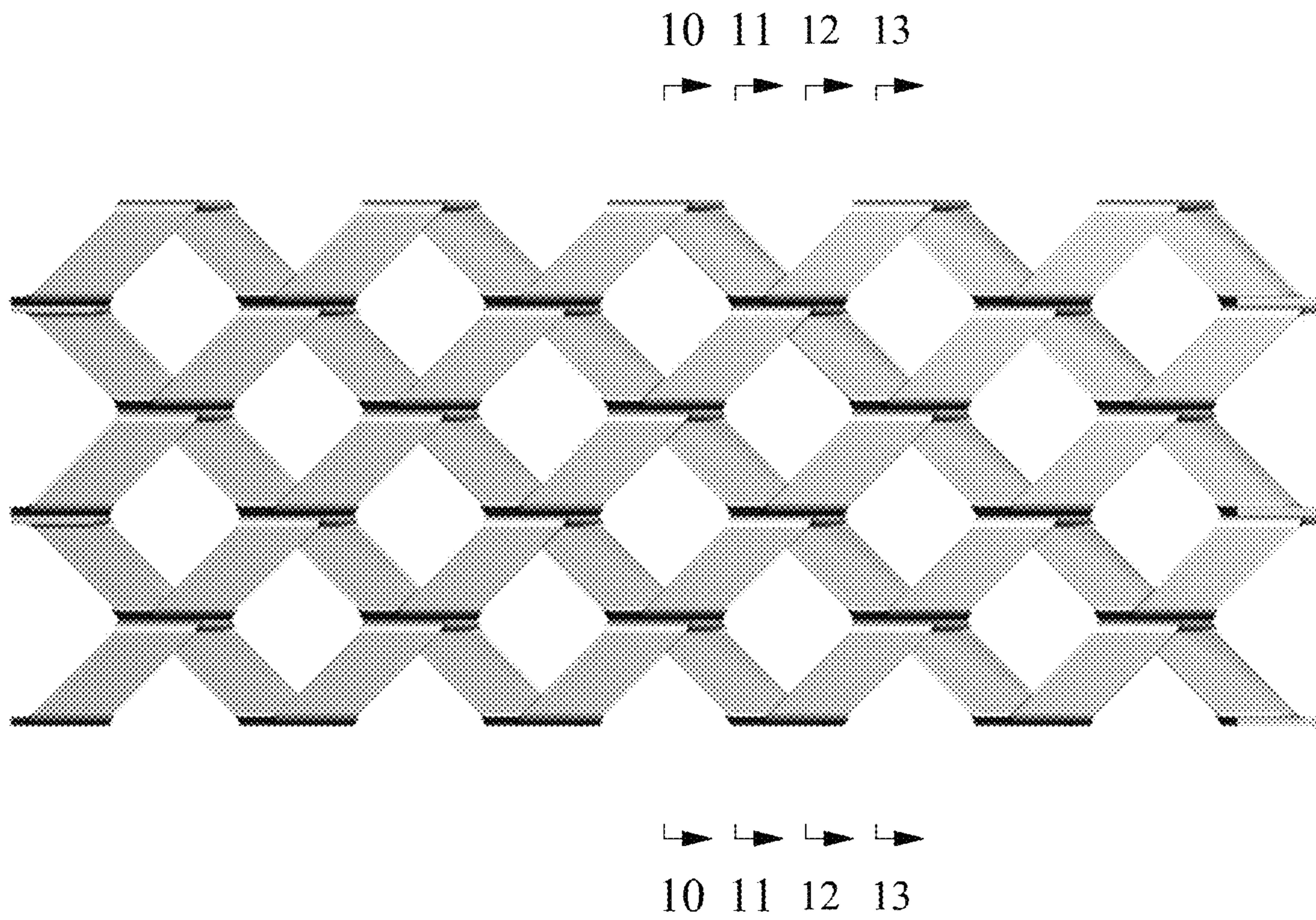

FIG. 5

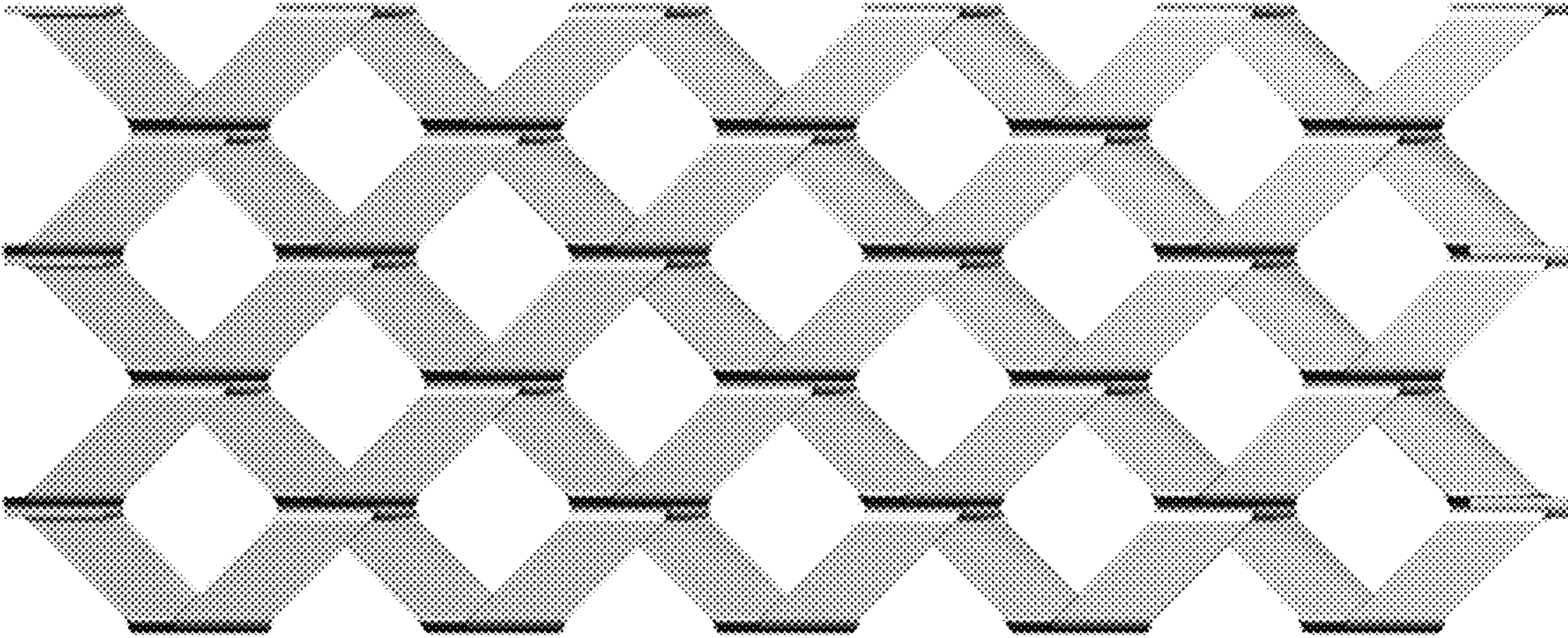

FIG. 6

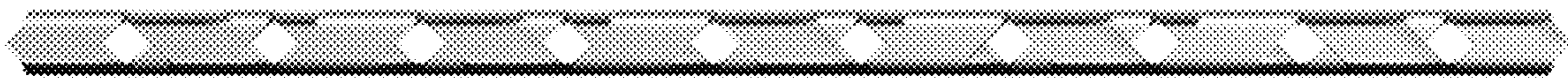

FIG. 7

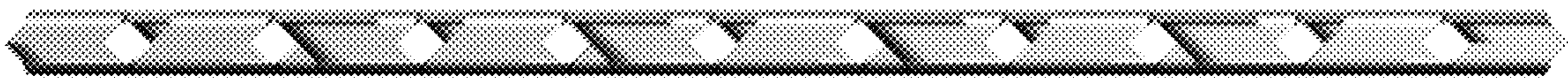

FIG. 8



FIG. 9



FIG. 10

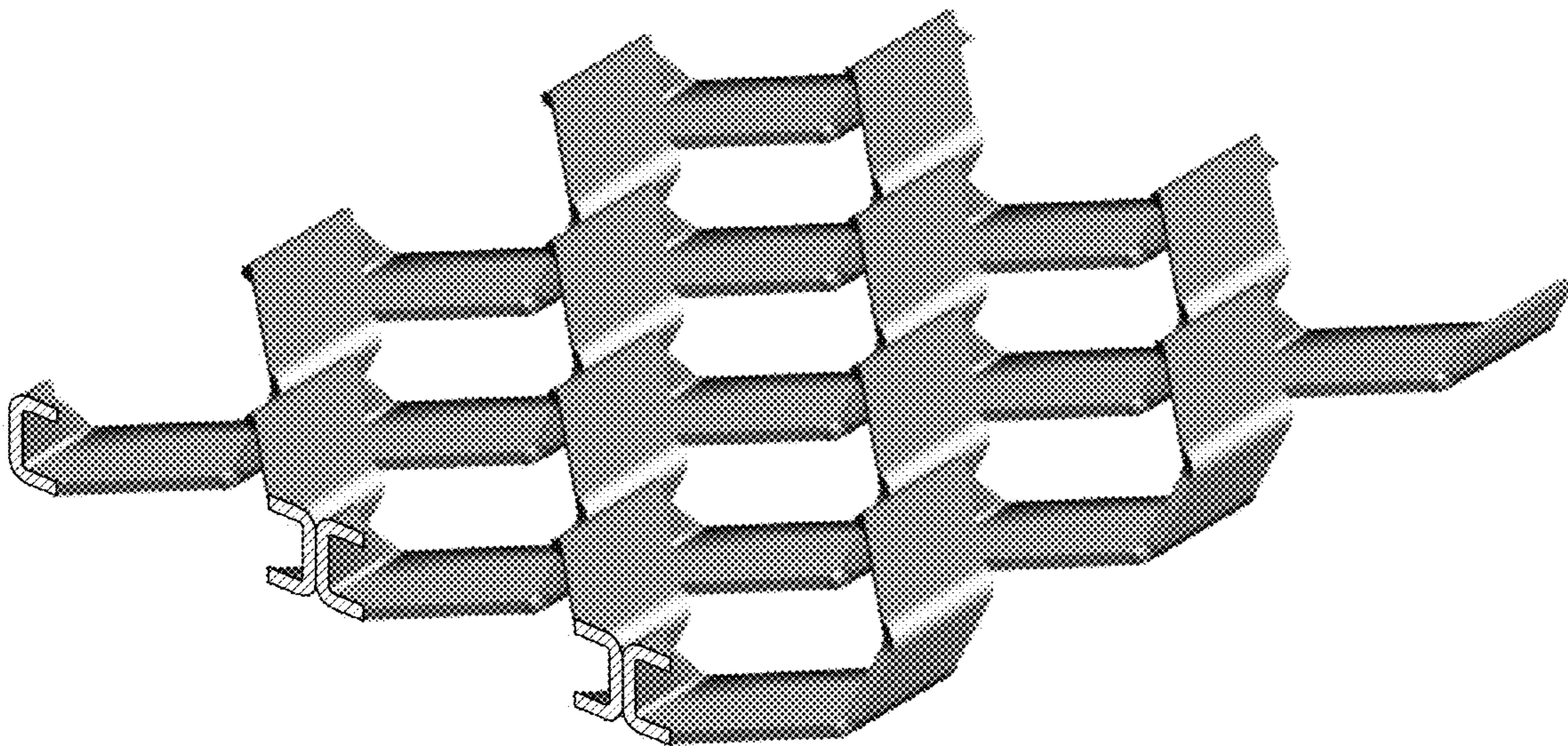

FIG. 11

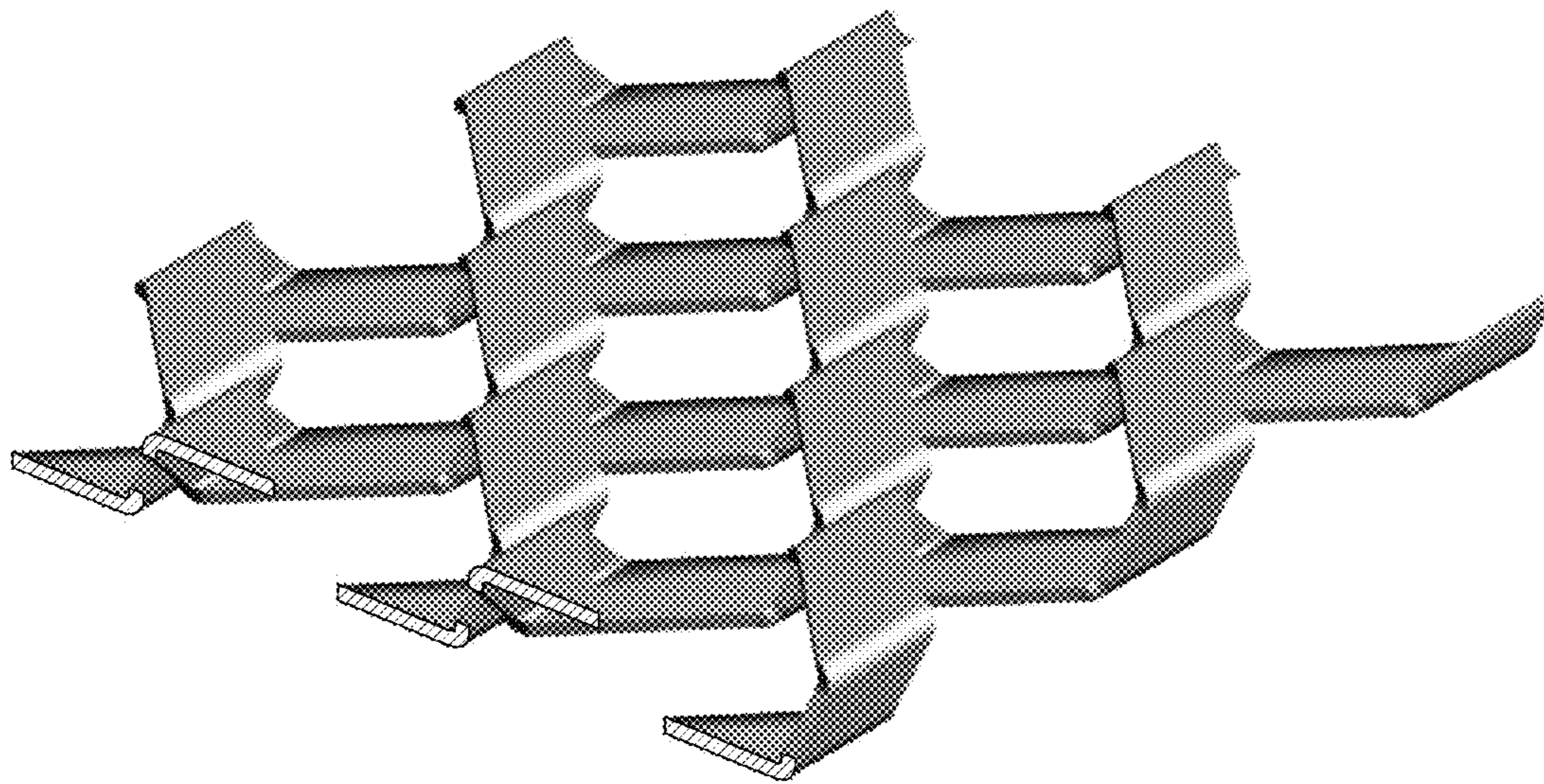

FIG. 12

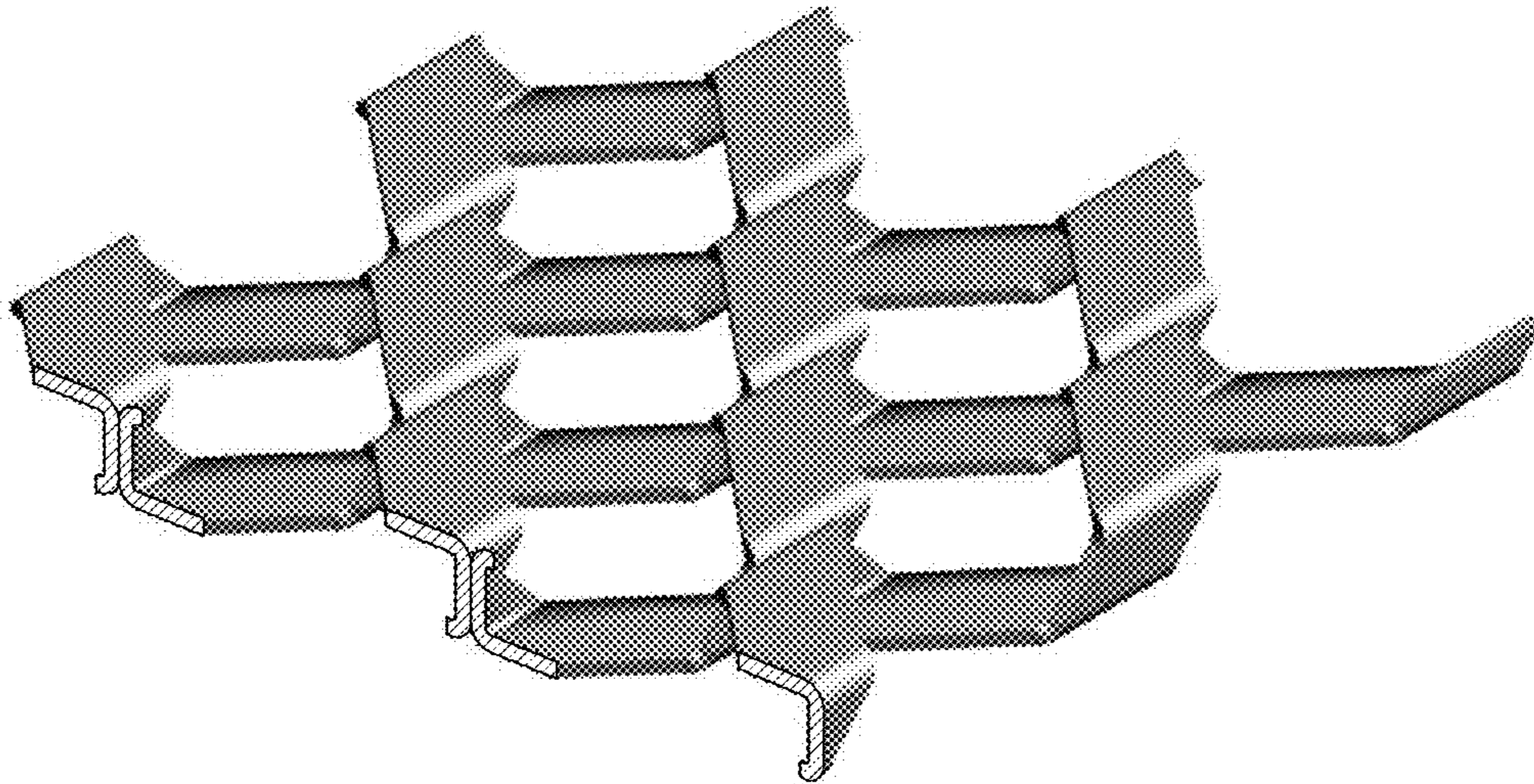

FIG. 13

