



US00D940669S

(12) **United States Design Patent** (10) **Patent No.:** **US D940,669 S**
Sambu et al. (45) **Date of Patent:** **** Jan. 11, 2022**

(54) **BOAT FOR SUBSTRATE PROCESSING APPARATUS**

(71) Applicant: **KOKUSAI ELECTRIC CORPORATION**, Tokyo (JP)
(72) Inventors: **Makoto Sambu**, Toyama (JP); **Makoto Tsuru**, Toyama (JP); **Satoshi Fujii**, Toyama (JP)
(73) Assignee: **KOKUSAI ELECTRIC CORPORATION**, Tokyo (JP)
(**) Term: **15 Years**
(21) Appl. No.: **29/691,588**
(22) Filed: **May 17, 2019**

(30) **Foreign Application Priority Data**

Nov. 19, 2018 (JP) 2018-025160
(51) **LOC (13) Cl.** **13-03**
(52) **U.S. Cl.**
USPC **D13/182**
(58) **Field of Classification Search**
USPC D13/182; D10/81; D26/27;
D16/230-234; D24/108, 164, 169, 170,
D24/233

(Continued)

(56) **References Cited**

U.S. PATENT DOCUMENTS

D853,979 S * 7/2019 Kagaya D13/182
D857,021 S * 8/2019 Ohta D14/435

(Continued)

FOREIGN PATENT DOCUMENTS

JP 1052358 S 10/1999
JP 1302035 S 5/2007

OTHER PUBLICATIONS

“Substrate Processing Boat.” (Design—© Questel) orbit.com. [Online PDF compilation of references] 89 pgs. Print Dates Range Nov. 28, 2019-May 31, 2013 [Retrieved Sep. 13, 2021].*

(Continued)

Primary Examiner — Manpreet S Matharu

Assistant Examiner — Suzanne E Tisdell

(74) *Attorney, Agent, or Firm* — Fitch, Even, Tabin & Flannery, LLP

(57) **CLAIM**

We claim the ornamental design for a boat for substrate processing apparatus, as shown and described.

DESCRIPTION

FIG. 1 is a front, top and right side perspective view of a boat for substrate processing apparatus showing our new design; FIG. 2 is a front elevational view thereof; FIG. 3 is a left side elevational view thereof; FIG. 4 is a right side elevational view thereof; FIG. 5 is a rear elevational view thereof; FIG. 6 is a top plan view thereof; FIG. 7 is a bottom plan view thereof. FIG. 8 is an enlarged cross-sectional view take along line 8-8 in FIG. 2 thereof; FIG. 9 is an enlarged cross-sectional view take along line 9-9 in FIG. 2 thereof; FIG. 10 is an enlarged portion view taken along line 10-10 in FIG. 2. thereof; FIG. 11 is an enlarged cross-sectional view take along line 11-11 in FIG. 8 thereof; and, FIG. 12 is an enlarged perspective view, which looked at the part shown by the solid line from the upper part. The dashed-dot-dashed lines represent the boundary lines of the claimed design. The broken lines are included for the purpose of illustrating portions of the article that form no part of the claimed design.

1 Claim, 6 Drawing Sheets

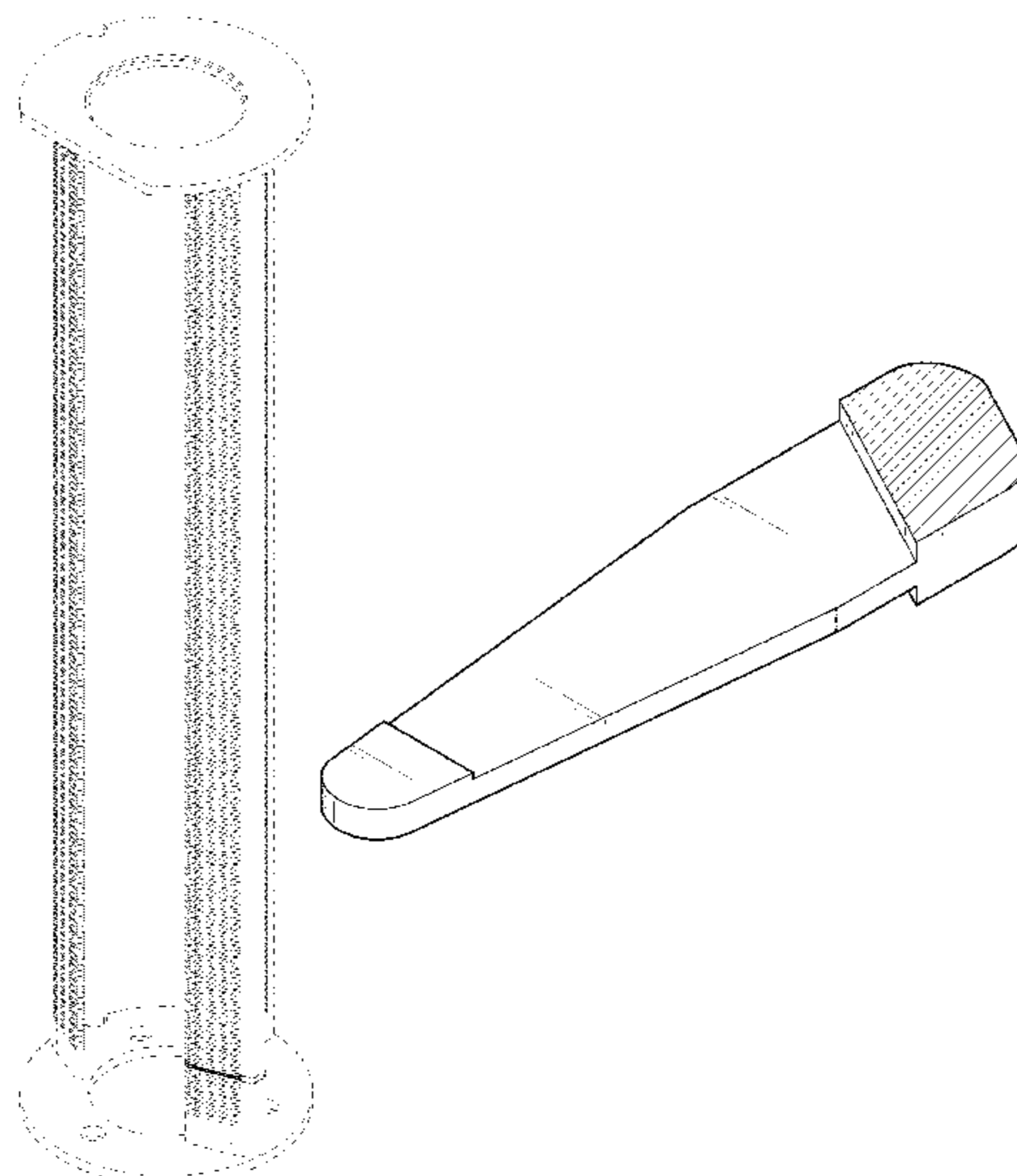

(58) **Field of Classification Search**

CPC . H01L 21/00; H01L 21/67; B65C 2009/0043;
B65C 2009/1846; B23K 26/00; B23K
26/0006; B23K 26/0096; B23K 26/08;
B23K 26/36; B23K 26/32; B23K 26/40;
H01S 5/00; H01S 5/02; H01S 5/04; H01S
5/10

See application file for complete search history.

(56) **References Cited**

U.S. PATENT DOCUMENTS

D858,467 S * 9/2019 Sawada D13/182
D865,689 S * 11/2019 Wang D13/182
D866,469 S * 11/2019 Hu H05K 7/026
D13/133
D872,038 S * 1/2020 Pan D13/182
D873,782 S * 1/2020 Garcia D13/182
D873,783 S * 1/2020 Pan D13/182
D892,754 S * 8/2020 Beckedahl D13/182
D893,438 S * 8/2020 Hasegawa D13/182
D906,273 S * 12/2020 Majima D13/182
D911,298 S * 2/2021 Krasnopolski D13/182
D911,986 S * 3/2021 Leifeste D13/182

OTHER PUBLICATIONS

“Quartz Boat for Diffusion of Wafer Processing.” Feb. 15, 2019.
MTI Corporation. <https://www.mtixtl.com/QuartzBoatEQ-QB-X025.aspx>.*

“Custom Quartz Wafer Carriers & Quartz Boats.” May 15, 2018.
MICQ. <https://www.micquartz.com/quartz-glass-products/quartz-components/custom-quartz-wafer-carriers/>.*

“Wafer Boats.” 10-15 Kyocera, <https://global.kyocera.com/prdct/fc/product/category/sapphire/sapphire006.html>.*

* cited by examiner

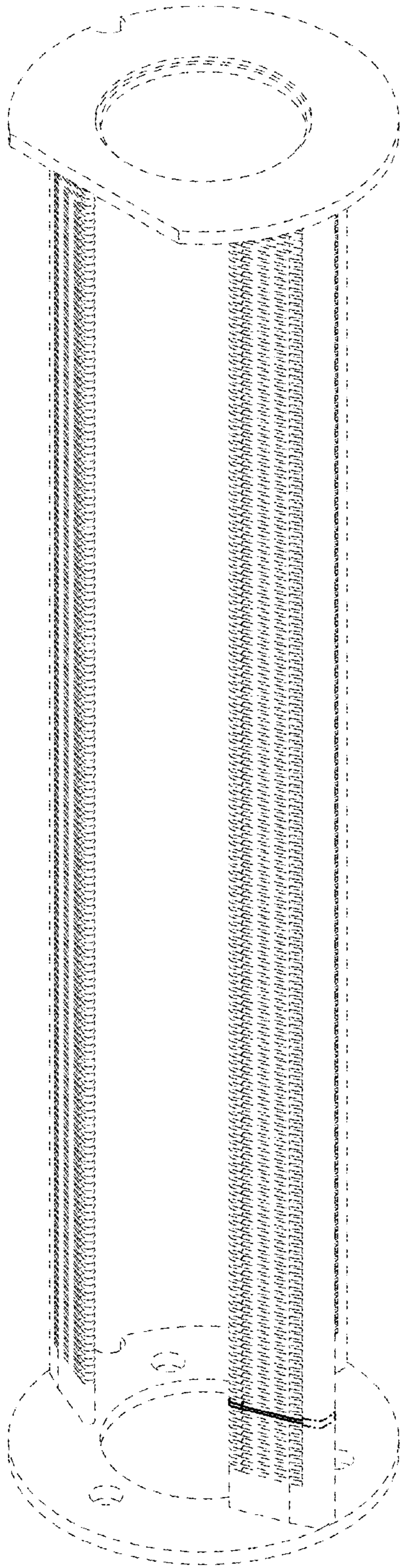

FIG. 1

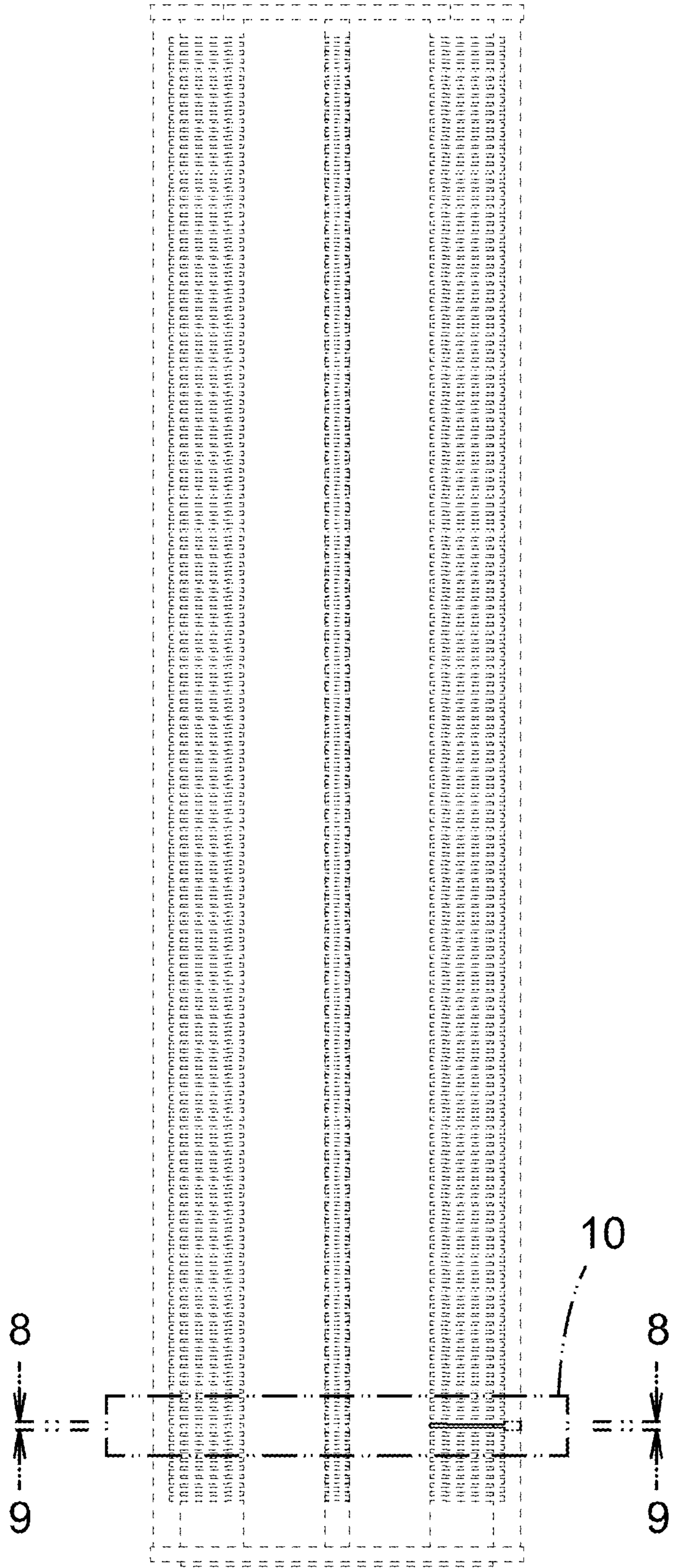

FIG. 2

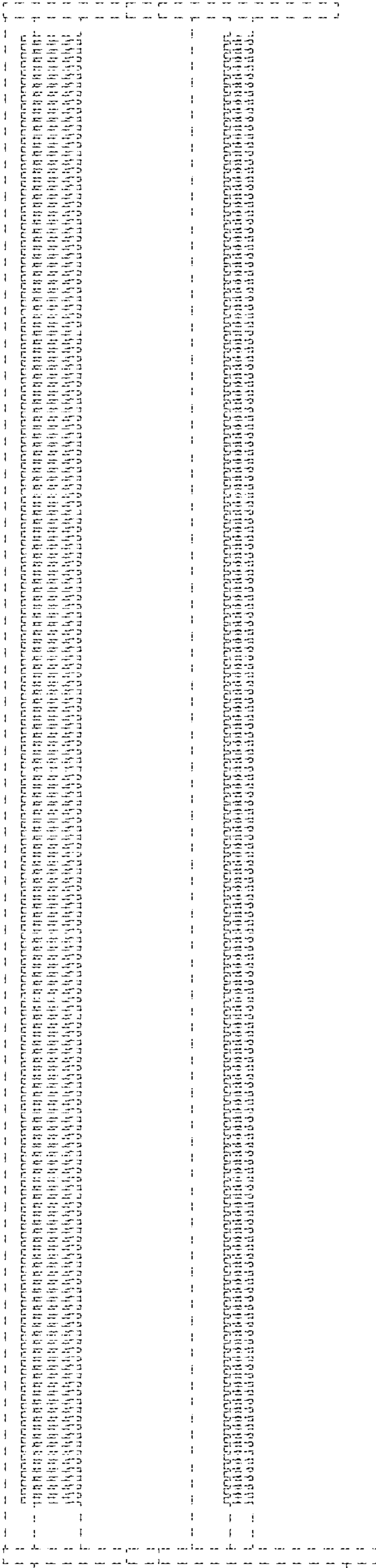

FIG. 3

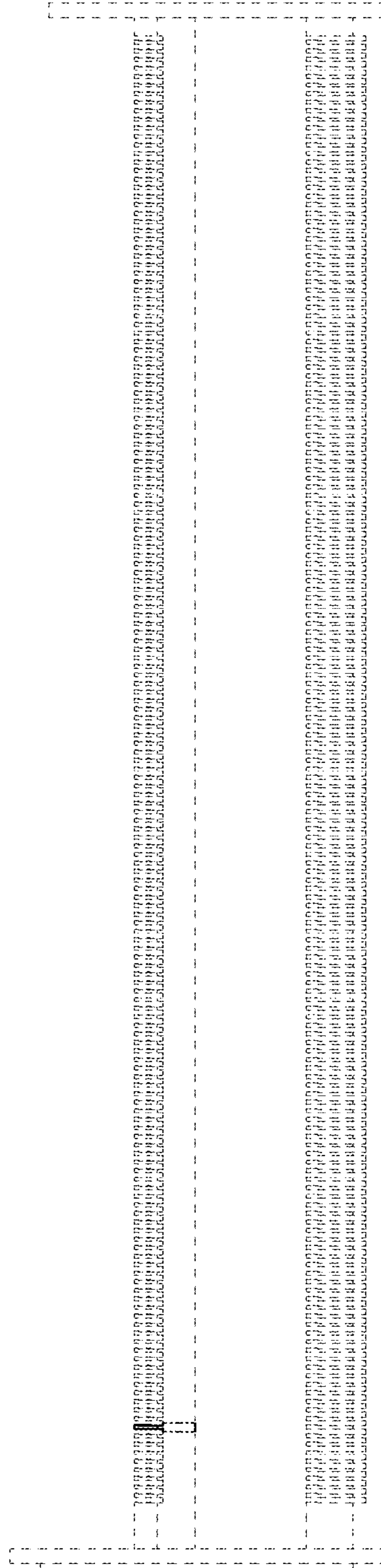

FIG. 4

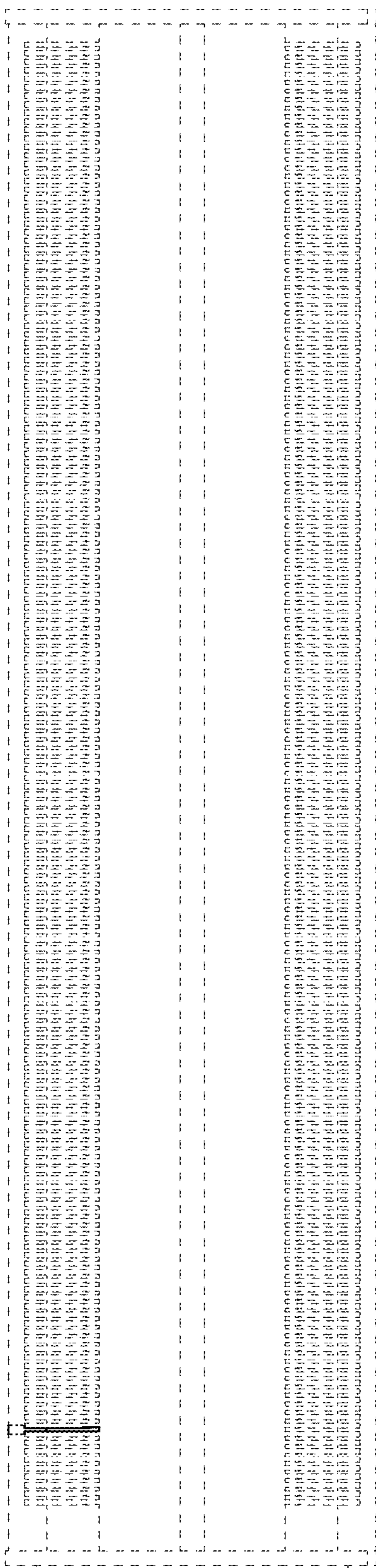

FIG. 5

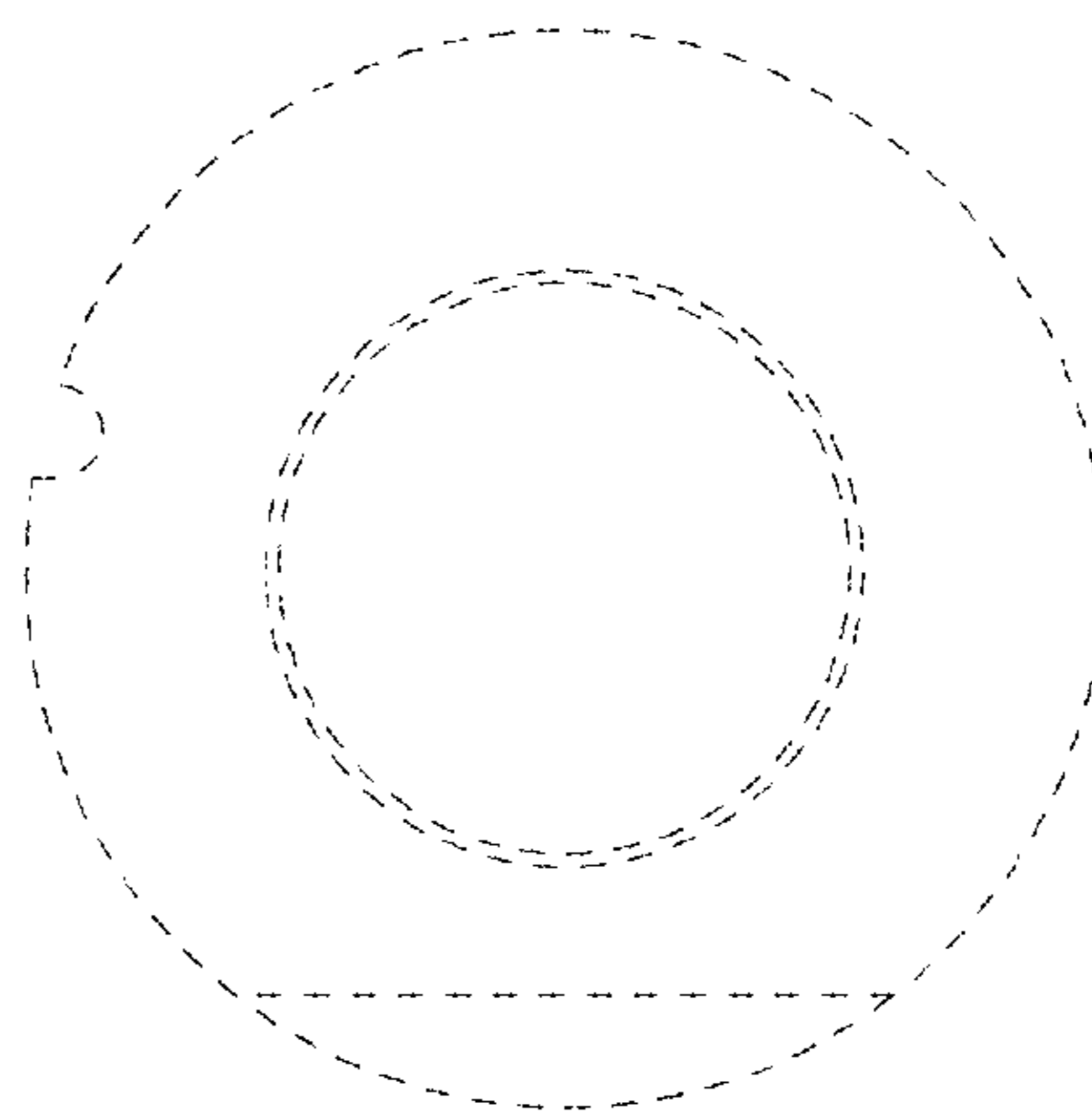

FIG. 6

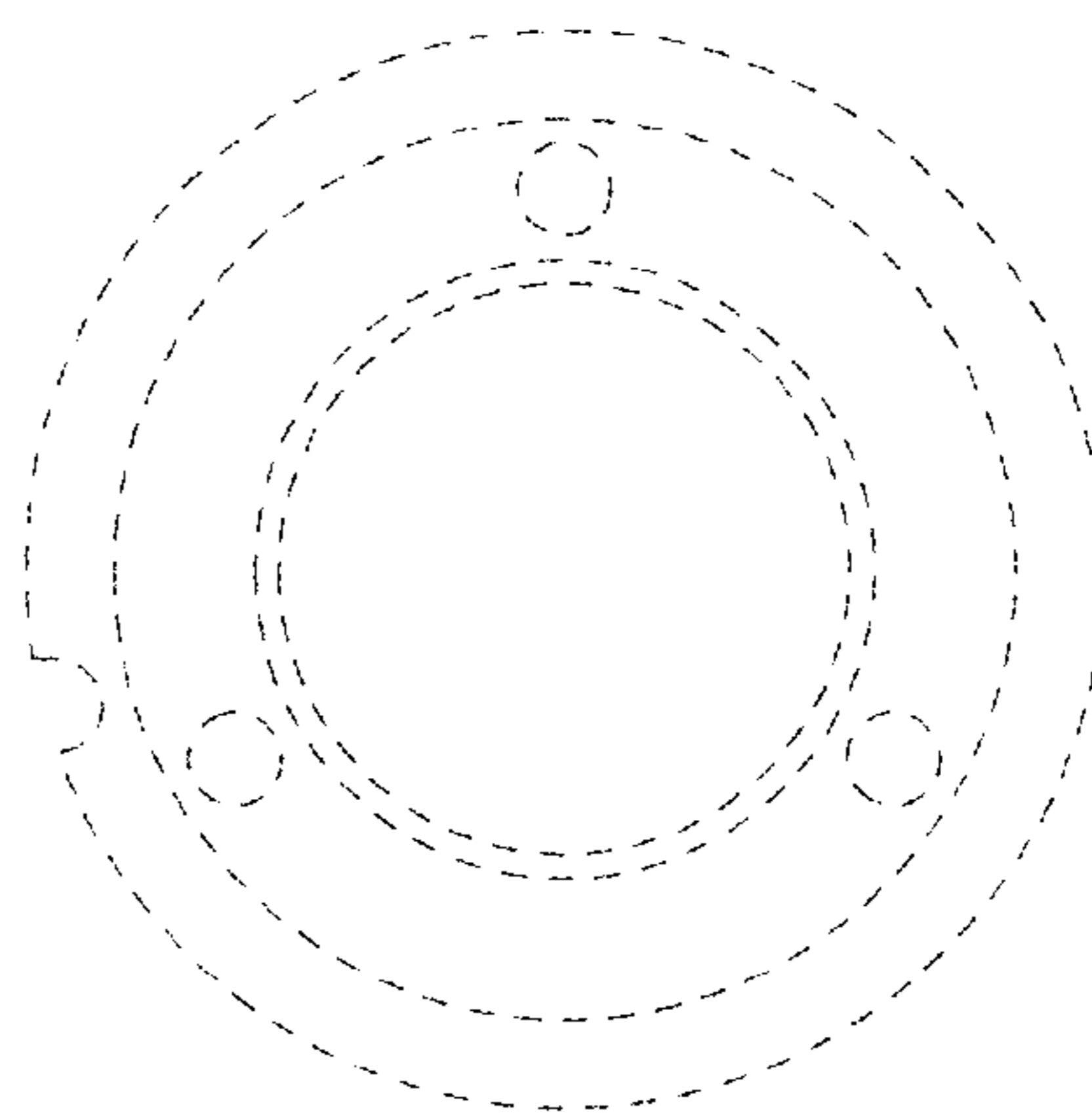

FIG. 7

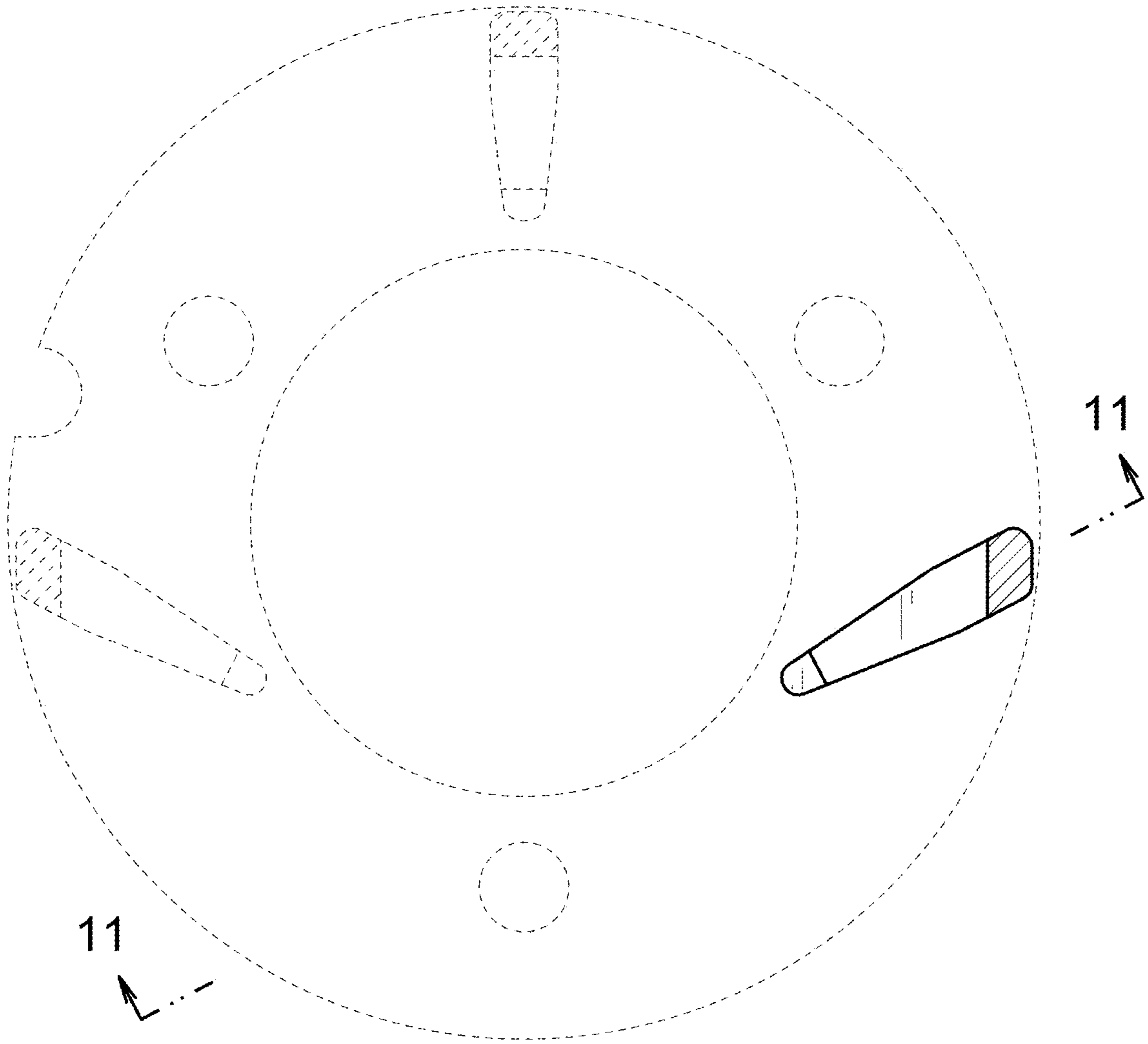

FIG. 8

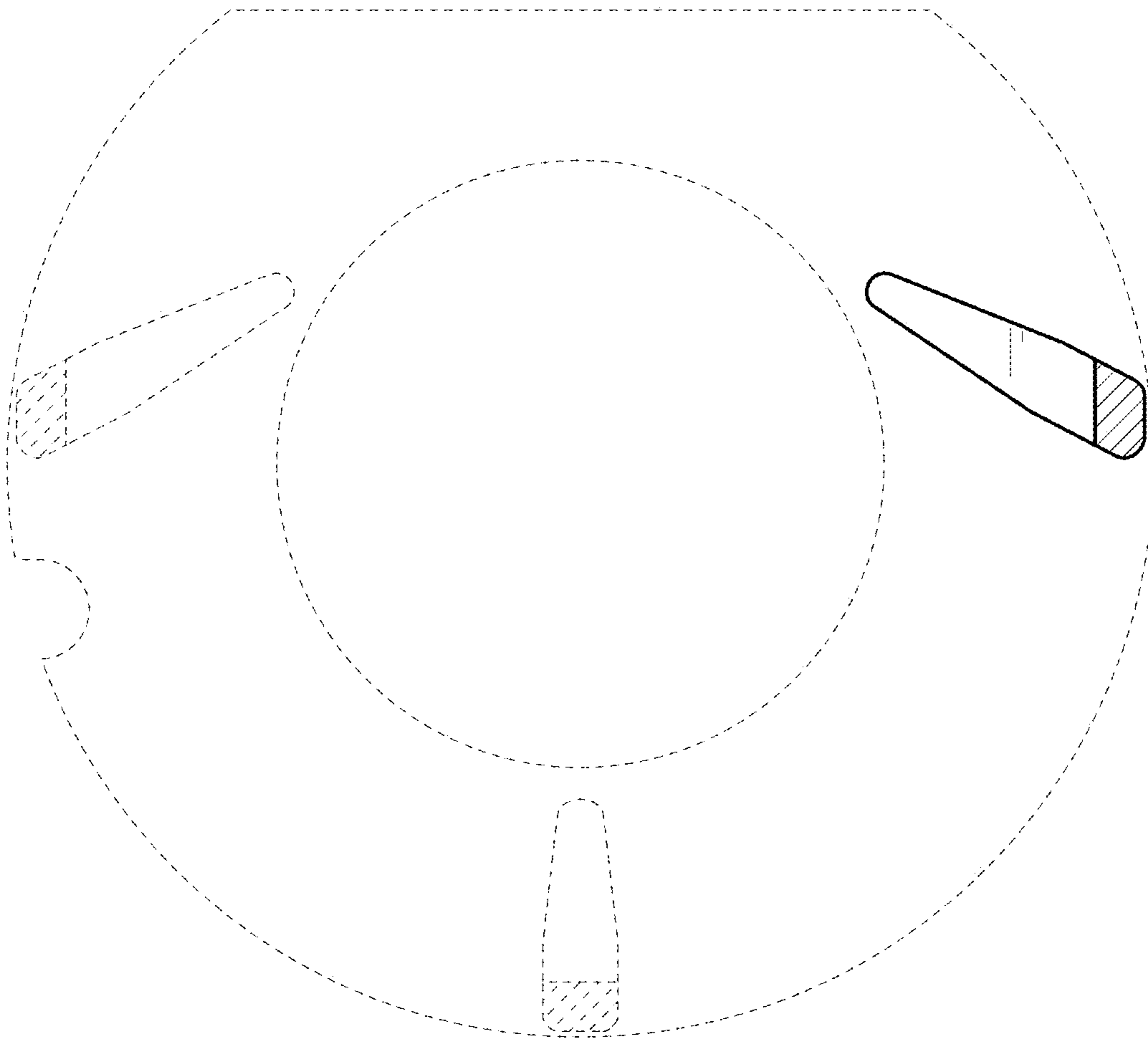

FIG. 9

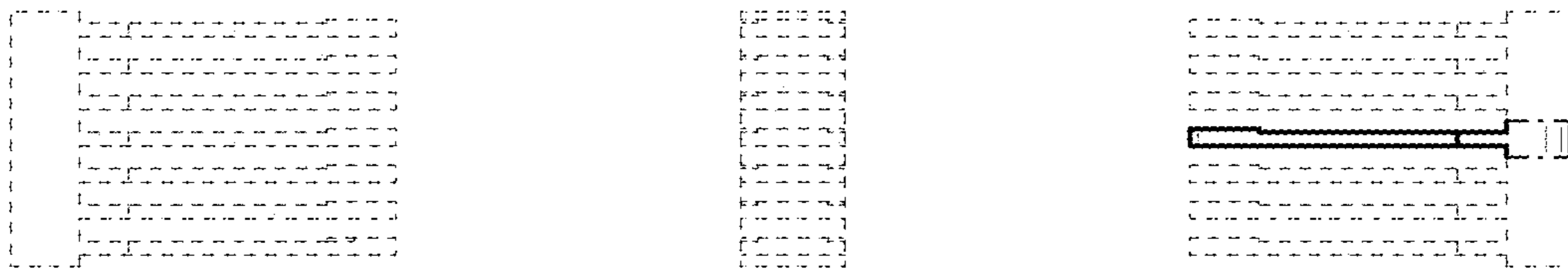

FIG. 10

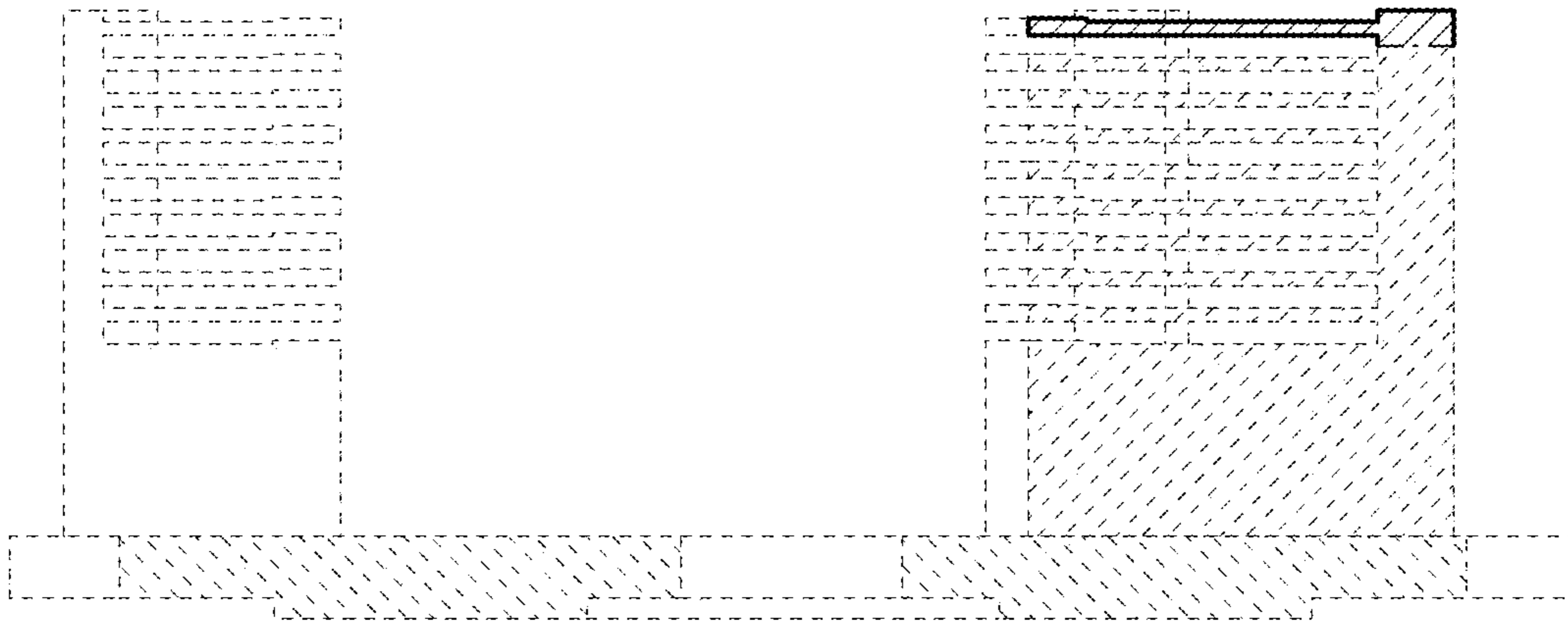

FIG. 11

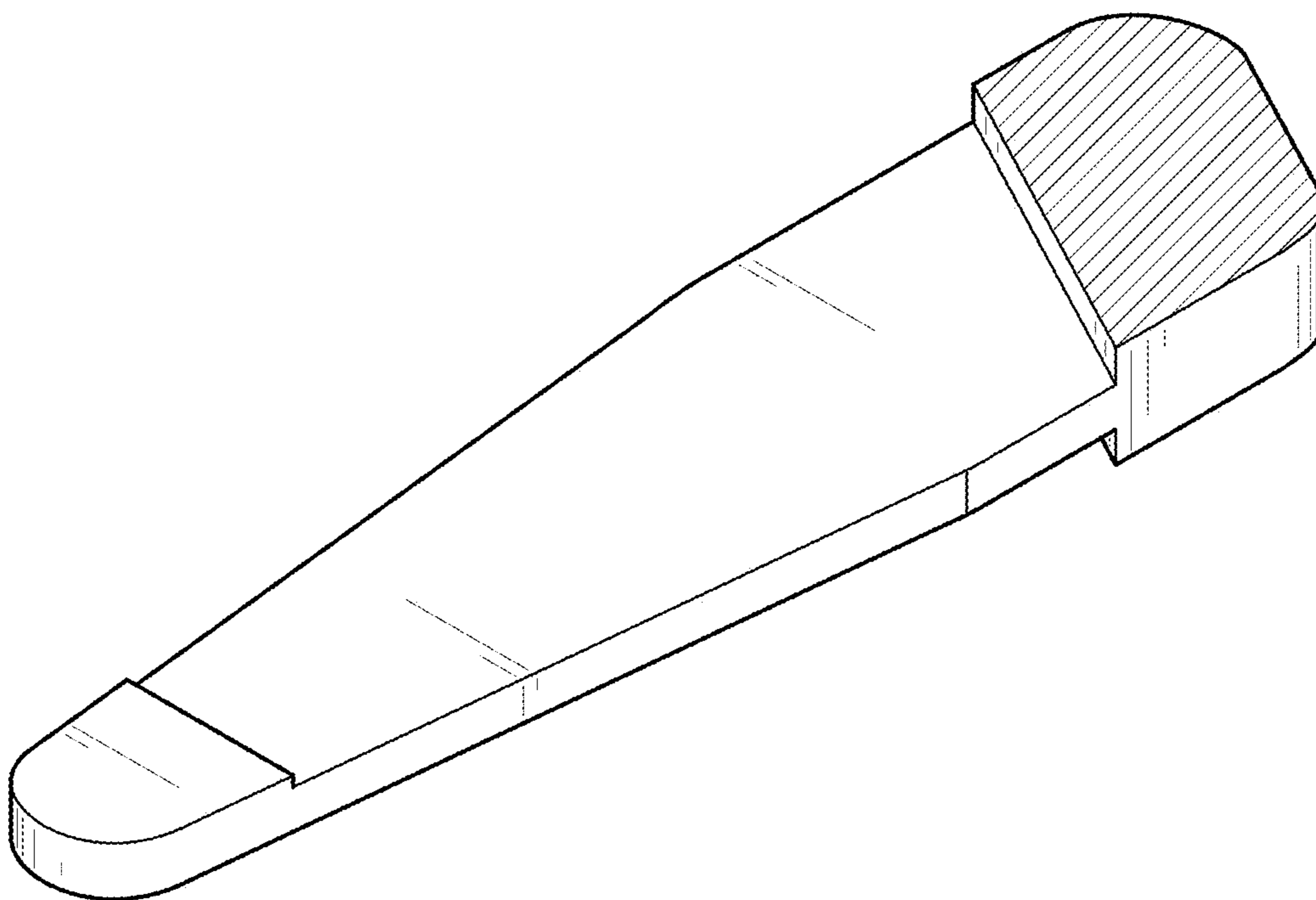

FIG. 12