



US00D940576S

(12) **United States Design Patent**
Nie et al.

(10) **Patent No.:** **US D940,576 S**
(45) **Date of Patent:** **** Jan. 11, 2022**

(54) **HIGH-SPEED TRAIN GEARBOX SENSING DEVICE**

(71) Applicant: **FATRI UNITED TESTING & CONTROL (QUANZHOU) TECHNOLOGIES CO., LTD.**,
Quanzhou (CN)

(72) Inventors: **Yongzhong Nie**, Quanzhou (CN);
Tingfang Zeng, Quanzhou (CN)

(**) Term: **15 Years**

(21) Appl. No.: **29/712,976**

(22) Filed: **Nov. 13, 2019**

(30) **Foreign Application Priority Data**

May 24, 2019 (CN) 201930259794.7

(51) **LOC (13) Cl.** **10-04**

(52) **U.S. Cl.**
USPC **D10/53; D15/148**

(58) **Field of Classification Search**
USPC D10/46, 49, 50, 51, 52, 53, 60, 82, 83,
D10/94, 95, 96, 98, 103; D12/42;
D13/103; D14/253; D15/138, 148, 149
CPC B61K 9/02; F16H 57/01; F16H 59/72;
G01H 11/00; G01H 11/08; G01K 7/18;
G01M 13/028; H01L 41/1132; H01L
41/18; H05K 9/0007
See application file for complete search history.

(56) **References Cited**

U.S. PATENT DOCUMENTS

D439,855 S * 4/2001 Caldeira D10/109.1
D447,969 S * 9/2001 Shimomoto D10/85
D448,694 S * 10/2001 Bush D10/104.1
D459,262 S * 6/2002 Kurz D10/104.1

D462,662 S * 9/2002 Lindekugel D13/146
D465,427 S * 11/2002 Wilda D10/85
D470,428 S * 2/2003 Kryskowski D10/85
D475,641 S * 6/2003 Glasson D10/65
D489,280 S * 5/2004 Runge D10/101
D534,818 S * 1/2007 Schoen D10/46
D546,720 S * 7/2007 Goh D10/81
D551,105 S * 9/2007 Brasse D10/85
D557,219 S * 12/2007 Detering D13/165
D611,860 S * 3/2010 Gismervik D10/101
D722,896 S * 2/2015 Lantzsch D10/57
D739,506 S * 9/2015 Taylor D23/259
D741,729 S * 10/2015 Lantzsch D10/57
D755,064 S * 5/2016 Saitoh D10/85
D755,655 S * 5/2016 Scott D10/81
D841,490 S * 2/2019 Boedhoe D10/56
D843,547 S * 3/2019 Toshida D23/207
D899,946 S * 10/2020 Polly D10/52
2020/0191647 A1 * 6/2020 Yongzhong G01H 11/08

* cited by examiner

Primary Examiner — Patricia A Palasik

(74) *Attorney, Agent, or Firm* — W&KIP

(57) **CLAIM**

The ornamental design for a high-speed train gearbox sensing device, as shown and described.

DESCRIPTION

FIG. 1 is a front view of a high-speed train gearbox sensing device;

FIG. 2 is a back view thereof;

FIG. 3 is a left view thereof;

FIG. 4 is a right view thereof;

FIG. 5 is a top view thereof;

FIG. 6 is a bottom view thereof; and,

FIG. 7 is a perspective thereof.

The broken lines depict portions of the high-speed train gearbox sensing device that form no part of the claimed design.

1 Claim, 7 Drawing Sheets

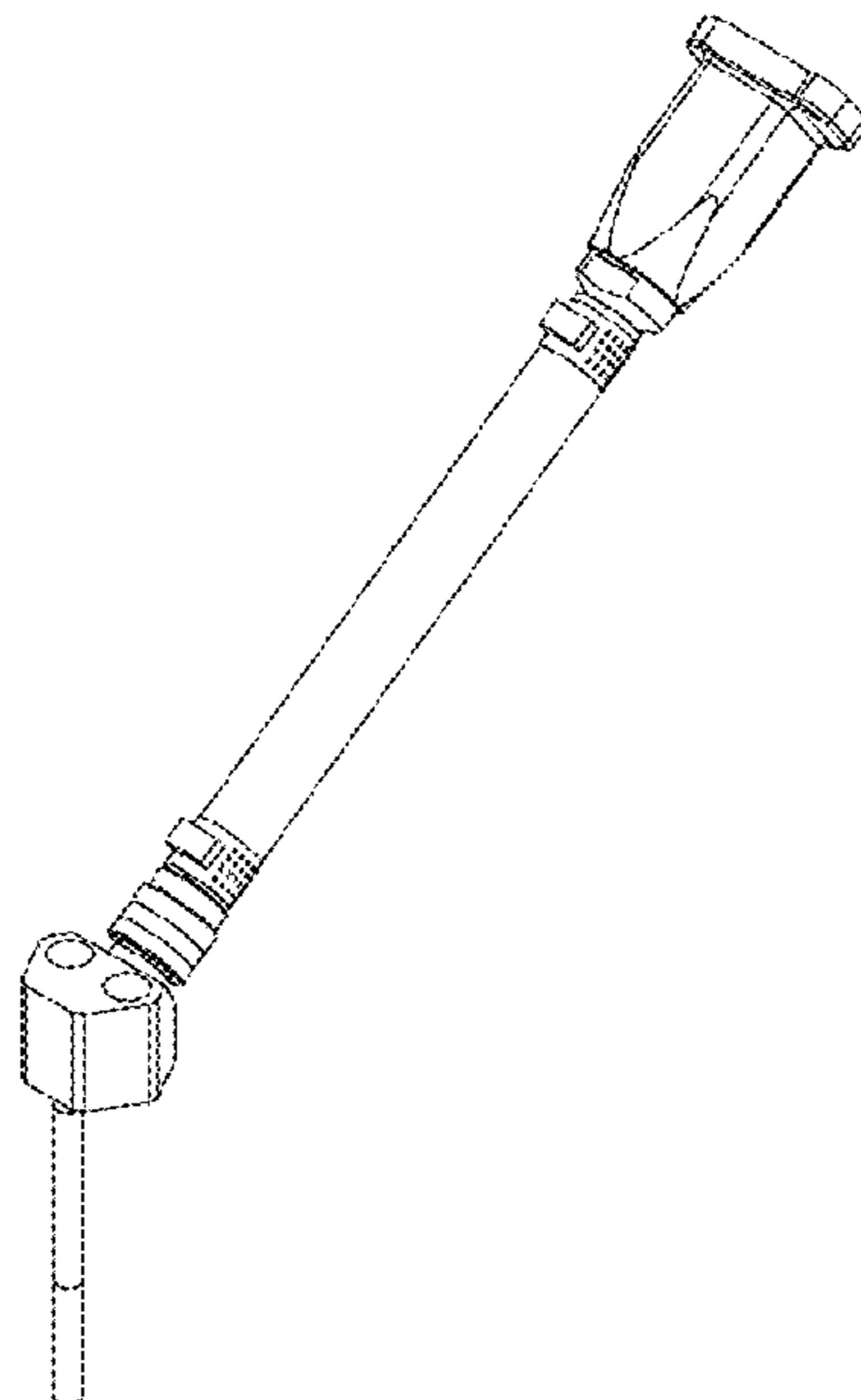

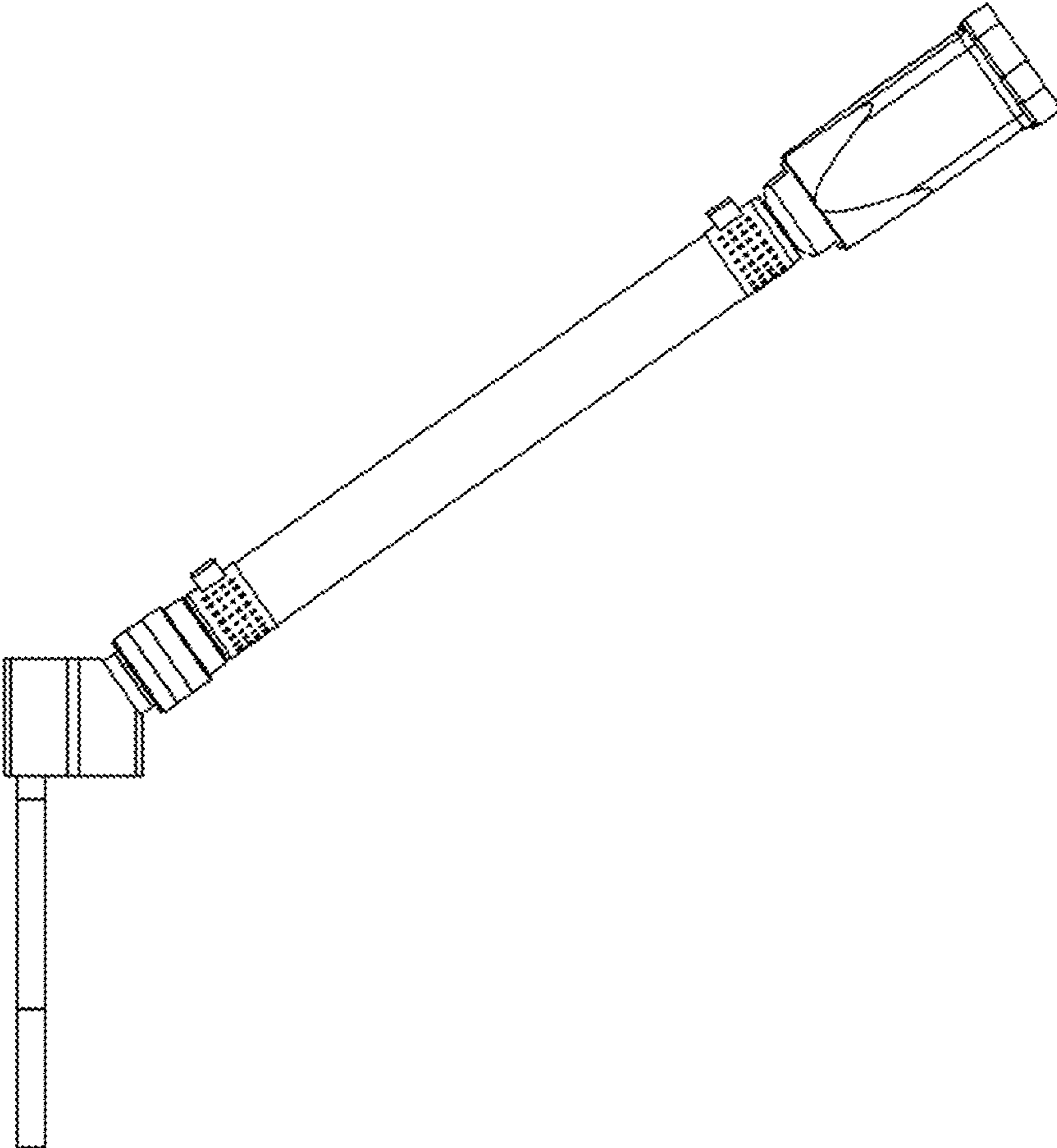

FIG.1

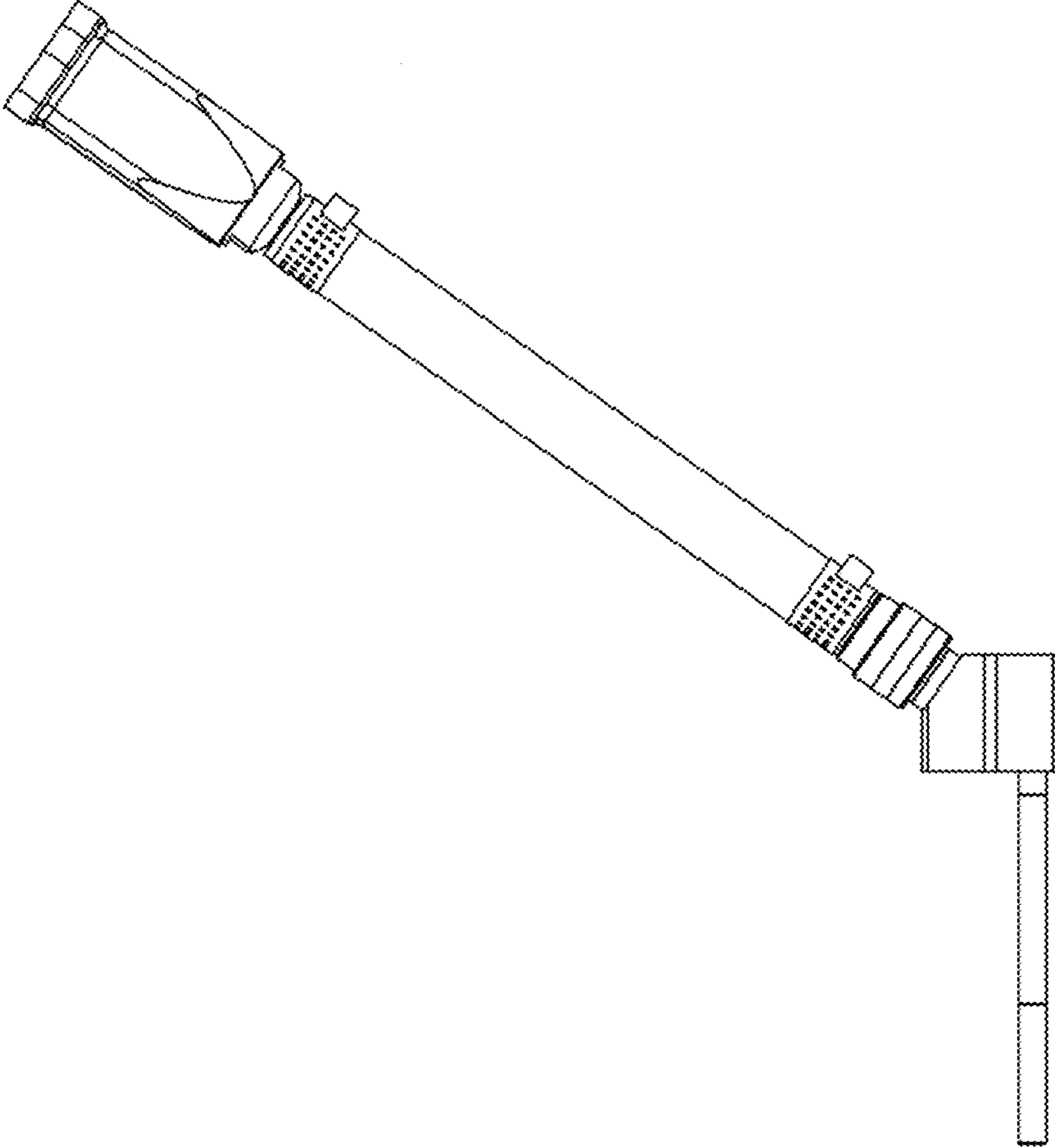

FIG.2

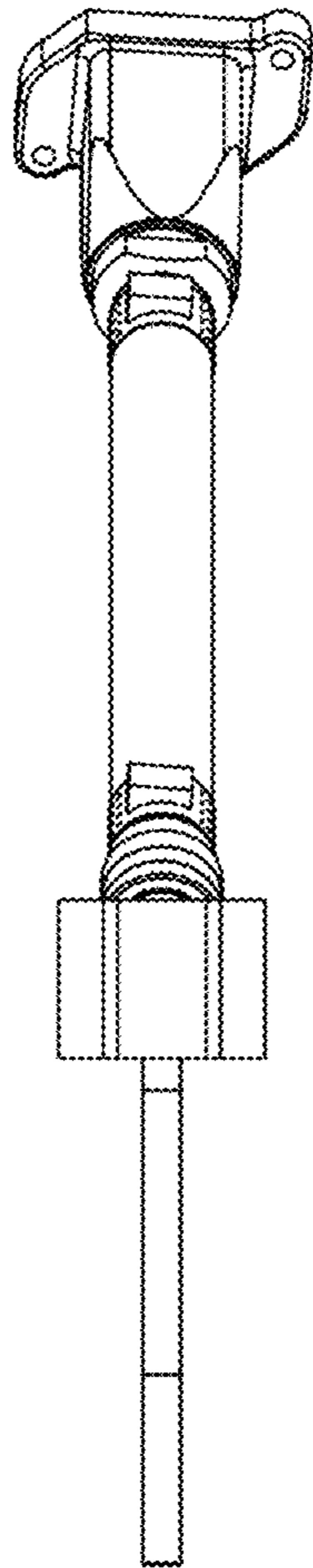

FIG.3

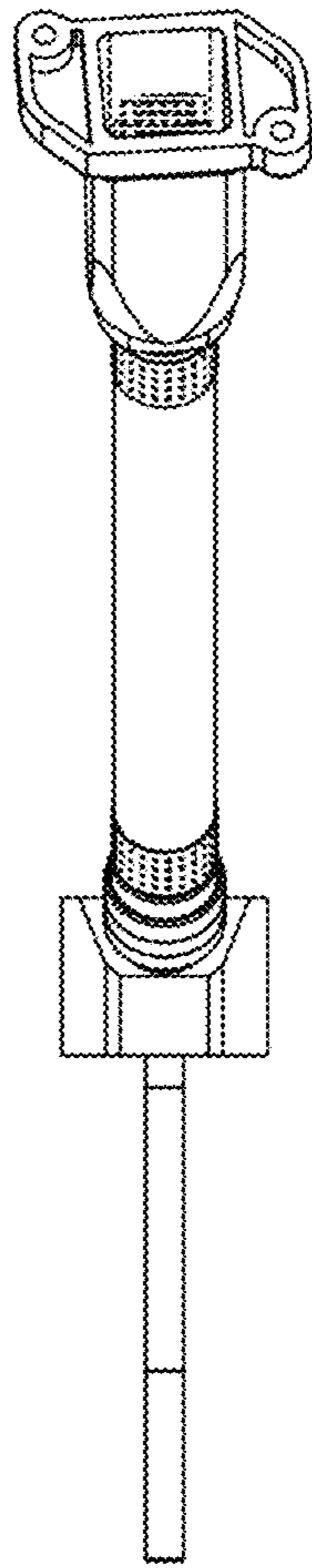

FIG.4

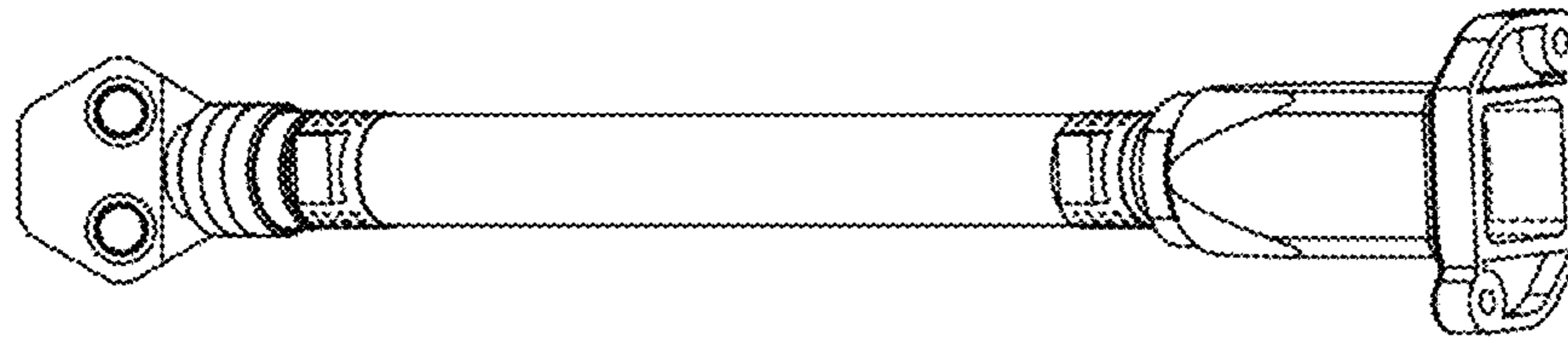

FIG.5

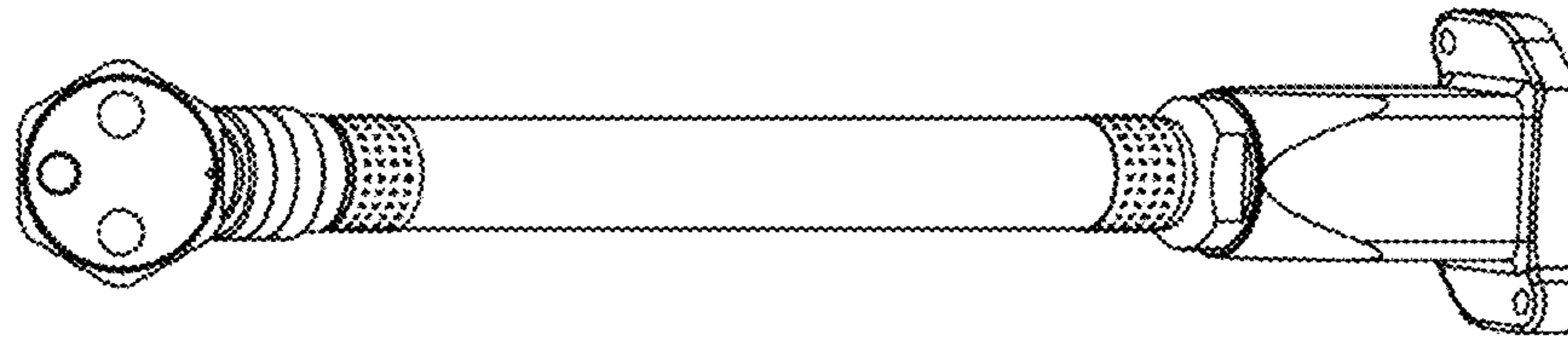

FIG. 6

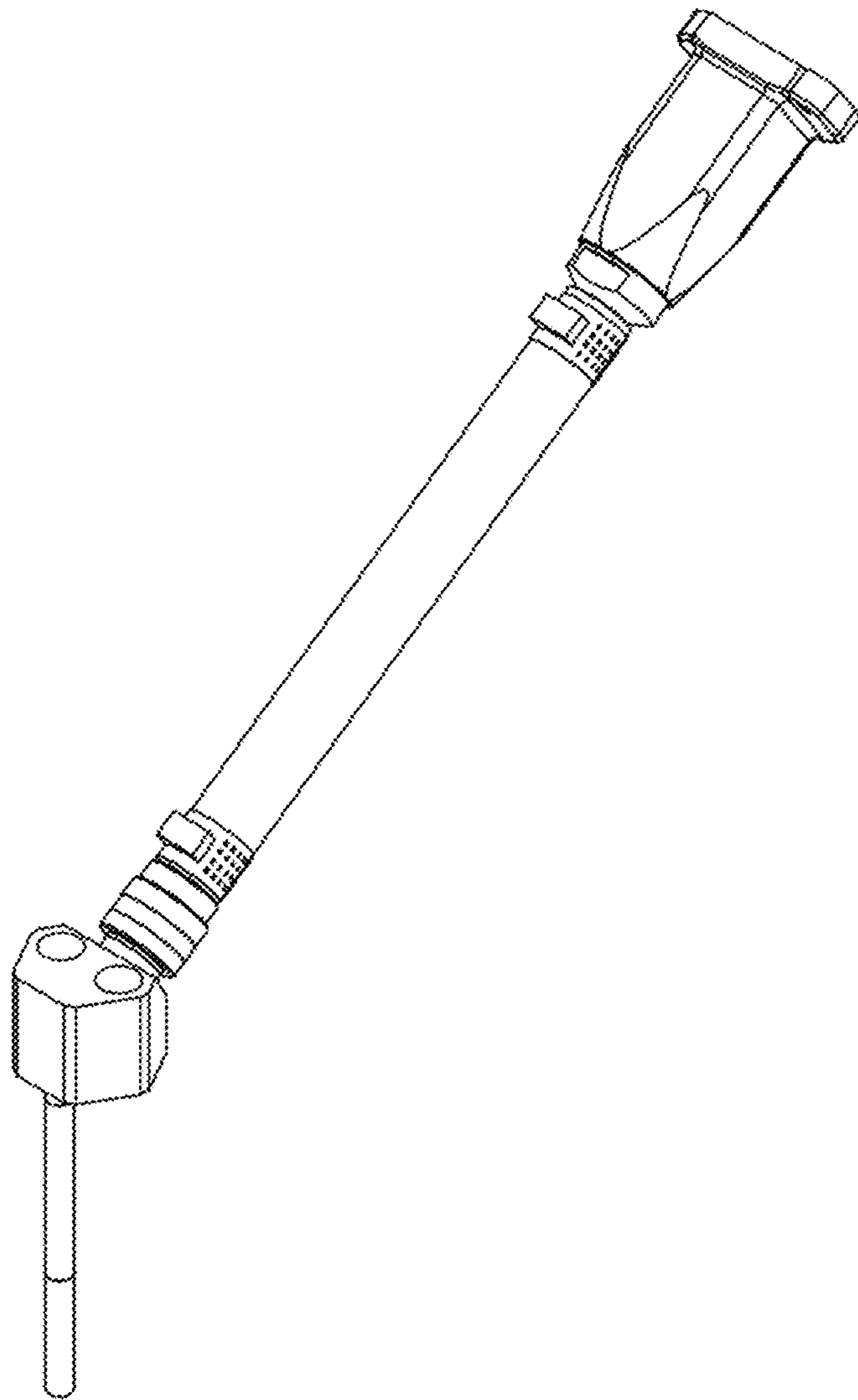

FIG.7