



US00D940500S

(12) **United States Design Patent**
Bannister et al.

(10) **Patent No.:** **US D940,500 S**
(45) **Date of Patent:** **** Jan. 11, 2022**

- (54) **LID**
- (71) Applicant: **SHARKNINJA OPERATING LLC**,
Needham, MA (US)
- (72) Inventors: **Sam William Bannister**, Leybourne
(GB); **Michael Sloban, Jr.**, Cambridge,
MA (US)
- (73) Assignee: **SHARKNINJA OPERATING LLC**,
Needham, MA (US)

1,997,914 A 4/1935 Pollard
 2,121,621 A 6/1938 Adams
 2,121,622 A 6/1938 Bean
 2,209,559 A 7/1940 Brennan et al.
 2,355,010 A 8/1944 Pera
 2,616,593 A 11/1952 Leibenhaut

(Continued)

FOREIGN PATENT DOCUMENTS

CN 1987102824 A 10/1987
 CN 1073149 A 6/1993

(Continued)

(**) Term: **15 Years**

(21) Appl. No.: **29/694,052**

(22) Filed: **Jun. 6, 2019**

(51) **LOC (13) Cl.** **31-00**

(52) **U.S. Cl.**
USPC **D7/391**; D7/376; D7/378

(58) **Field of Classification Search**
USPC D7/372, 376–386, 391, 392, 392.1, 393,
D7/412–413, 443, 602, 629, 665–666,
D7/669, 679, 693–694

CPC A21C 1/02; A21C 1/04; A23N 1/00; A23N
1/02; A47J 43/04; A47J 43/25; A47J
43/27; A47J 43/042; A47J 43/044; A47J
43/046; A47J 43/075; A47J 43/0705;
A47J 43/0722; A47J 43/0727; B01F 3/00;
B01F 3/0807; B01F 3/0853; B01F
13/0059; B01F 13/0064; B02C 1/08;
B02C 2/04; B02C 4/42; B02C 4/142;
B02C 4/143; B02C 4/423; B02C 13/1835;
B28C 5/10; B28C 5/12; B28C 5/14;
B28C 5/16; B65D 51/242

See application file for complete search history.

(56) **References Cited**

U.S. PATENT DOCUMENTS

293,190 A 2/1884 Moore
 959,581 A 5/1910 Newton

OTHER PUBLICATIONS

US 6,592,248 B2, 07/2003, Kressin et al. (withdrawn)
(Continued)

Primary Examiner — Ricky Pham

(74) *Attorney, Agent, or Firm* — Burns & Levinson, LLP;
Joseph M. Maraia

(57) **CLAIM**

The ornamental design for a lid, as shown and described.

DESCRIPTION

FIG. 1 is a perspective view of a lid, showing our new design;
 FIG. 2 is a top view of the embodiment shown in FIG. 1;
 FIG. 3 is a bottom view of the embodiment shown in FIG. 1;
 FIG. 4 is a side view of the embodiment shown in FIG. 1;
 FIG. 5 is another side view of the embodiment shown in FIG. 1;
 FIG. 6 is a front view of the embodiment shown in FIG. 1;
 and,
 FIG. 7 is a rear view of the embodiment shown in FIG. 1.

1 Claim, 5 Drawing Sheets

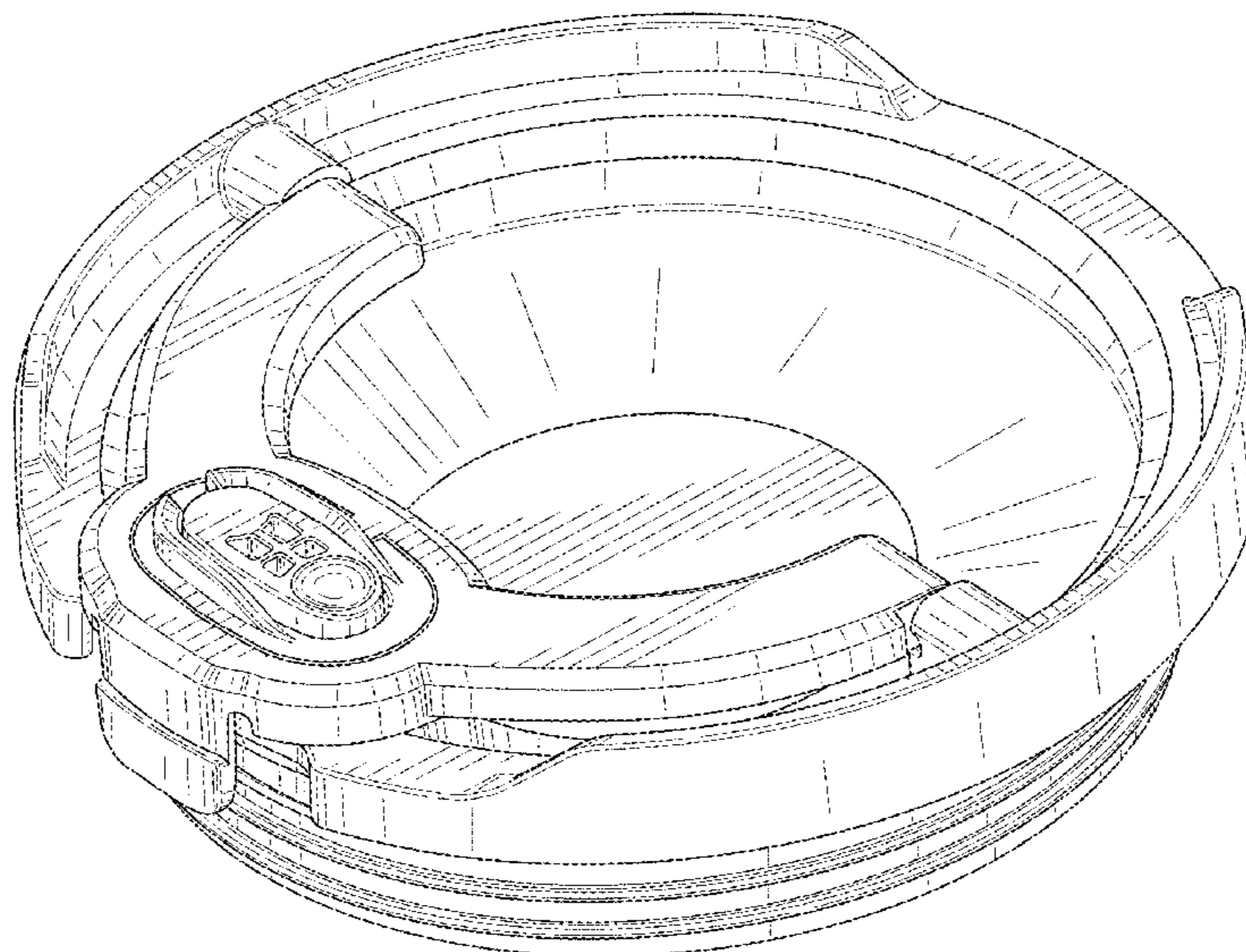

(56)

References Cited

U.S. PATENT DOCUMENTS

D780,507 S 3/2017 Barquin et al.
 D783,340 S 4/2017 Palermo et al.
 D783,355 S 4/2017 Tu
 D784,761 S 4/2017 Tu
 9,624,024 B2 4/2017 Vilinsky
 9,630,828 B1 4/2017 Gardner
 D789,735 S 6/2017 Palermo et al.
 D789,736 S 6/2017 Palermo et al.
 9,675,212 B2 6/2017 Hewitt et al.
 9,687,111 B1 6/2017 Trojan
 D793,153 S 8/2017 Tu
 D794,384 S 8/2017 Lee
 D797,496 S 9/2017 Gee, II et al.
 D798,101 S 9/2017 Rose et al.
 9,763,461 B2 9/2017 Vastardis et al.
 D804,248 S 12/2017 Tu
 D807,700 S 1/2018 Tu
 D808,718 S 1/2018 Coakley
 D808,719 S 1/2018 Coakley
 9,855,535 B2 1/2018 Arnett et al.
 D809,333 S 2/2018 Lee
 9,888,807 B2 2/2018 Starr et al.
 D811,806 S 3/2018 Bock
 D813,603 S 3/2018 Tu
 D813,604 S 3/2018 Tu
 9,907,430 B2 3/2018 Vastardis et al.
 9,924,824 B2 3/2018 Backus
 9,924,837 B1 3/2018 Trojan
 9,924,838 B2 3/2018 Potter et al.
 9,930,986 B2 4/2018 Arai et al.
 D816,383 S 5/2018 Liang
 9,962,030 B2 5/2018 Avins et al.
 9,993,105 B2 6/2018 Bishop et al.
 9,999,319 B2 6/2018 Kim
 D821,806 S 7/2018 Coakley et al.
 10,055,347 B1 8/2018 Trojan
 D832,029 S 10/2018 Gee, II et al.
 10,105,003 B2 10/2018 Tsutsumi et al.
 10,117,444 B2 11/2018 Vastardis et al.
 10,123,650 B2 11/2018 McLaughlin et al.
 D834,878 S 12/2018 Moon et al.
 D835,463 S 12/2018 Coakley
 10,143,323 B2 12/2018 Backus
 10,182,680 B2 1/2019 Koetz
 10,196,595 B2 2/2019 Butte
 10,213,047 B2 2/2019 Boggavarapu
 D842,643 S 3/2019 Mullen et al.
 D842,644 S 3/2019 Kettavong et al.
 10,226,147 B2 3/2019 Harper
 D846,337 S 4/2019 Duan et al.
 D846,338 S 4/2019 Smith et al.
 D846,339 S 4/2019 Smith
 10,299,629 B2 5/2019 Bascom et al.
 D851,982 S 6/2019 Deleo et al.
 D852,566 S 7/2019 Chen
 D860,724 S 9/2019 Kassin et al.
 D865,438 S 11/2019 Coakley et al.
 D865,441 S * 11/2019 Lowette D7/392
 D867,804 S 11/2019 Gronkowski
 D876,885 S * 3/2020 Smith D7/391
 10,617,260 B2 4/2020 Sapire
 10,736,465 B2 8/2020 Dickson, Jr. et al.
 10,799,071 B2 10/2020 Pamplin
 2001/0000570 A1 5/2001 Aarts
 2002/0009401 A1 1/2002 Osborn
 2003/0227818 A1 12/2003 Villwock et al.
 2004/0025703 A1 2/2004 Ming
 2004/0065668 A1 4/2004 Lee
 2004/0155063 A1 8/2004 Hofeldt
 2004/0159243 A1 8/2004 Theodos
 2004/0173105 A1 9/2004 Kim et al.
 2004/0195120 A1 10/2004 Anderson
 2004/0208079 A1 10/2004 Hein
 2005/0229795 A1 10/2005 Stuckey
 2005/0269336 A1 12/2005 Rockhill et al.

2006/0000369 A1 1/2006 Hsu
 2006/0120215 A1 6/2006 Sands
 2006/0124536 A1 6/2006 Guerrero
 2007/0183256 A1 8/2007 Sands
 2008/0037360 A1 2/2008 McGill
 2008/0067195 A1 3/2008 Jennings et al.
 2009/0084275 A1 4/2009 Liang
 2009/0165655 A1 7/2009 Aonuma
 2009/0229478 A1 9/2009 Wu
 2009/0266787 A1 10/2009 Son
 2009/0297671 A1 12/2009 Basker et al.
 2010/0003379 A1 1/2010 Zoss et al.
 2010/0203209 A1 8/2010 Fishbein et al.
 2011/0127297 A1 6/2011 Jennings et al.
 2012/0152131 A1 6/2012 Sands
 2012/0196014 A1 8/2012 Yao
 2013/0133521 A1 5/2013 Vastardis
 2014/0247686 A1 9/2014 Arnett et al.
 2014/0286123 A1 9/2014 Arnett et al.
 2014/0290503 A1 10/2014 Bae
 2015/0059597 A1 3/2015 Lee
 2015/0098299 A1 4/2015 Sapire
 2015/0138910 A1 5/2015 Cha et al.
 2015/0146496 A1 5/2015 Lucon et al.
 2015/0201808 A1 7/2015 Katsuki et al.
 2015/0208844 A1 7/2015 Liang
 2015/0351567 A1 12/2015 Tristram
 2016/0183582 A1 6/2016 Bauer
 2016/0220071 A1 8/2016 Hewitt et al.
 2016/0255983 A1 9/2016 Barquin et al.
 2016/0324358 A1 11/2016 Backus
 2016/0324369 A1 11/2016 Lee
 2016/0331182 A1 11/2016 Golino
 2016/0345773 A1 12/2016 Tonelli et al.
 2016/0348962 A1 12/2016 Roekens et al.
 2016/0367063 A1 12/2016 Vastardis et al.
 2017/0007067 A1 1/2017 Shima et al.
 2017/0049260 A1 2/2017 Beber et al.
 2017/0086622 A1 3/2017 Chung
 2017/0095122 A1 4/2017 Hoare et al.
 2017/0143155 A1 5/2017 Lin
 2017/0150744 A1 6/2017 Wangler
 2017/0164776 A1 6/2017 Floessholzer et al.
 2017/0224166 A1 8/2017 Sedlacek et al.
 2017/0231431 A1 8/2017 Maeng
 2017/0245668 A1 8/2017 Upston et al.
 2017/0295982 A1 10/2017 Holzbauer et al.
 2017/0295992 A1 10/2017 Mangold et al.
 2017/0303571 A1 10/2017 Alden
 2017/0341253 A1 11/2017 Arriens et al.
 2018/0014695 A1 1/2018 Gross et al.
 2018/0043321 A1 2/2018 Mochizuki
 2018/0079584 A1 3/2018 Jung
 2018/0098666 A1 4/2018 Le
 2018/0192814 A1 7/2018 Gormley et al.
 2018/0192815 A1 7/2018 Vastardis et al.
 2018/0199762 A1 7/2018 Kim
 2018/0220829 A1 8/2018 Zhang et al.
 2018/0222679 A1 8/2018 Iwasaka et al.
 2018/0296022 A1 10/2018 Avins et al.
 2018/0310769 A1 11/2018 Kim
 2018/0326378 A1 11/2018 Moon
 2018/0360256 A1 12/2018 Ford et al.
 2018/0360271 A1 12/2018 Katsuki et al.
 2019/0000272 A1 1/2019 Katsuki et al.
 2019/0009233 A1 1/2019 Furman et al.
 2019/0059409 A1 2/2019 Vastardis et al.
 2020/0281408 A1 9/2020 Bannister
 2020/0281409 A1 9/2020 Bannister
 2020/0281410 A1 9/2020 Bannister

FOREIGN PATENT DOCUMENTS

CN 1255841 A 6/2000
 CN 2390533 Y 8/2000
 CN 1432518 A 7/2003
 CN 1162115 C 8/2004
 CN 1525830 A 9/2004
 CN 1586378 A 3/2005

(56)

References Cited

FOREIGN PATENT DOCUMENTS

CN	1213686	C	8/2005	CN	206062911	U	4/2017
CN	1655707	A	8/2005	CN	106659310	A	5/2017
CN	2730269	Y	10/2005	CN	106724559	A	5/2017
CN	1792306	A	6/2006	CN	106724947	A	5/2017
CN	1268263	C	8/2006	CN	106742714	A	5/2017
CN	2808015	Y	8/2006	CN	106798496	A	6/2017
CN	1282438	C	11/2006	CN	206227556	U	6/2017
CN	100337572	C	9/2007	CN	106974565	A	7/2017
CN	201001611	Y	1/2008	CN	206295245	U	7/2017
CN	201067329	Y	6/2008	CN	206324658	U	7/2017
CN	100418461	C	9/2008	CN	107019425	A	8/2017
CN	100522753	C	8/2009	CN	107019441	A	8/2017
CN	100581426	C	1/2010	CN	107049072	A	8/2017
CN	101663142	A	3/2010	CN	107088005	A	8/2017
CN	101238036	B	5/2010	CN	107095598	A	8/2017
CN	101291609	B	6/2010	CN	107148234	A	9/2017
CN	201505039	U	6/2010	CN	107157356	A	9/2017
CN	101779928	A	7/2010	CN	107212772	A	9/2017
CN	101181127	B	2/2011	CN	206453647	U	9/2017
CN	102058327	A	5/2011	CN	107224225	A	10/2017
CN	102083345	A	6/2011	CN	107280517	A	10/2017
CN	102123600	A	7/2011	CN	107303150	A	10/2017
CN	201899357	U	7/2011	CN	107319965	A	11/2017
CN	201977619	U	9/2011	CN	107373278	A	11/2017
CN	102245068	A	11/2011	CN	105682517	B	12/2017
CN	101854839	B	5/2012	CN	107411477	A	12/2017
CN	102429590	A	5/2012	CN	107411589	A	12/2017
CN	101637242	B	6/2012	CN	206688628	U	12/2017
CN	102670096	A	9/2012	CN	107595164	A	1/2018
CN	101522039	B	10/2012	CN	206867155	U	1/2018
CN	202681713	U	1/2013	CN	107713697	A	2/2018
CN	202698925	U	1/2013	CN	107713825	A	2/2018
CN	207613666	U	1/2013	CN	105902133	B	3/2018
CN	102984951	B	3/2013	CN	107788844	A	3/2018
CN	202875005	U	4/2013	CN	107822529	A	3/2018
CN	203074329	U	7/2013	CN	107874651	A	4/2018
CN	203447138	U	2/2014	CN	107912982	A	4/2018
CN	103857317	A	6/2014	CN	207168385	U	4/2018
CN	203647102	U	6/2014	CN	107997525	A	5/2018
CN	102355839	B	8/2014	CN	108013791	A	5/2018
CN	103960992	A	8/2014	CN	108065810	A	5/2018
CN	104305872	A	1/2015	CN	108078438	A	5/2018
CN	102292011	B	4/2015	CN	207341667	U	5/2018
CN	102631153	B	4/2015	CN	108143312	A	6/2018
CN	204274217	A	4/2015	CN	207506464	U	6/2018
CN	204600200	U	9/2015	CN	108272359	A	7/2018
CN	204698308	A	10/2015	CN	108283444	A	7/2018
CN	103813741	B	12/2015	CN	207640256	U	7/2018
CN	103354793	B	2/2016	CN	108378725	A	8/2018
CN	105455688	A	4/2016	CN	108415344	A	8/2018
CN	105520659	A	4/2016	CN	108451395	A	8/2018
CN	105686701	A	6/2016	CN	108471901	A	8/2018
CN	105919396	A	9/2016	CN	106580132	B	9/2018
CN	105996826	A	10/2016	CN	108478009	A	9/2018
CN	205658804	U	10/2016	CN	108577547	A	9/2018
CN	106073538	A	11/2016	CN	108577597	A	9/2018
CN	106108596	A	11/2016	CN	108601485	A	9/2018
CN	106108599	A	11/2016	CN	108606663	A	10/2018
CN	106108709	A	11/2016	CN	108652478	A	10/2018
CN	106136903	A	11/2016	CN	207940815	U	10/2018
CN	106136961	A	11/2016	CN	108742189	A	11/2018
CN	106136962	A	11/2016	CN	108903698	A	11/2018
CN	103126552	B	12/2016	CN	208030887	U	11/2018
CN	106231966	A	12/2016	CN	109044075	A	12/2018
CN	106235907	A	12/2016	CN	109091035	A	12/2018
CN	106264202	A	1/2017	CN	109124296	A	1/2019
CN	106333616	A	1/2017	CN	305916020	S	7/2020
CN	106361183	A	2/2017	EP	0676161		7/1998
CN	106377152	A	2/2017	EP	3424380	A1	1/2019
CN	106377181	A	2/2017	GB	2556646	A	6/2018
CN	106419642	A	2/2017	GN	108652478	A	10/2018
CN	104720553	B	3/2017	GN	108670063	A	10/2018
CN	103720339	B	4/2017	GN	108720603	A	11/2018
CN	104853657	B	4/2017	JP	1523840		4/2015
CN	106580133	A	4/2017	JP	1528172	S	7/2015
				JP	1559194		8/2016
				JP	1618973		11/2018
				JP	1618976		11/2018
				JP	1659173		4/2020

(56)

References Cited

FOREIGN PATENT DOCUMENTS

KR	101821786	1/2018
WO	2008034020 A1	3/2008
WO	2008095309 A1	8/2008
WO	2009001244 A2	12/2008
WO	2015097606 A3	7/2015
WO	2016165454 A1	10/2016
WO	2017100326 A1	6/2017
WO	2017147059 A1	8/2017
WO	2017153341 A1	9/2017
WO	2017165422 A1	9/2017
WO	2017211987 A1	12/2017
WO	2018006776 A1	1/2018
WO	2018007831 A1	1/2018
WO	2018014226 A1	1/2018
WO	2018024371 A1	2/2018
WO	2018043872 A1	3/2018
WO	2018071589 A1	4/2018
WO	2018072504 A1	4/2018
WO	2018072505 A1	4/2018
WO	2018075446 A1	4/2018
WO	2018092997 A1	5/2018
WO	2018103312 A1	6/2018
WO	2018115402 A1	6/2018
WO	2018127716 A1	7/2018
WO	2018135697 A1	7/2018
WO	2018148418 A1	8/2018
WO	2018148954 A1	8/2018
WO	2018159958 A1	9/2018
WO	2018186598 A1	10/2018
WO	2018190537 A1	10/2018
WO	2018231103 A1	12/2018
WO	2018234275 A1	12/2018
WO	2019006983 A1	1/2019
WO	2019007920 A1	1/2019
WO	2019010504 A1	1/2019
WO	2019035592 A1	2/2019
WO	2019036486 A1	2/2019
WO	2019030803 A1	11/2019
WO	2019030805 A1	11/2019

OTHER PUBLICATIONS

International Search Report for International Application No. PCT/US2020/021718 filed Mar. 9, 2020; dated May 19, 2020; 6 pages.
 International Search Report for International Application No. PCT/US2020/021719 filed Mar. 9, 2020; dated May 19, 2020; 6 pages.

Written Opinion for International Application No. PCT/US2020/021718 filed Mar. 9, 2020; dated May 19, 2020; 8 pages.
 Written Opinion for International Application No. PCT/US2020/021719 filed Mar. 9, 2020; dated May 19, 2020; 8 pages.
 Japanese Design Application No. 201927097 filed Dec. 6, 2019; Notice of Allowance dated Jun. 12, 2020; 10 pages.
 Japanese Design Application No. 201927098 filed Dec. 6, 2019; Notice of Allowance dated Jun. 12, 2020; 10 pages.
 Amazon.com; “Addwin Countertop Blender Professional Commercial Mixer Blender”; Nov. 8, 2018; <https://www.amazon.com/dp/B07KBYWB7L/> (Year: 2018); 1 page.
 Chinese Application No. 201930680320X filed Dec. 6, 2019; Chinese Office Action with English Translation dated Jul. 23, 2020; 3 pages.
 International Search Report for International Application No. PCT/US2020/021728; International Filing Date: Mar. 9, 2020; dated Jul. 16, 2020; 7 pages.
 International Search Report for International Application No. PCT/US2020/037484; International Filing Date: Jun. 12, 2020; dated Sep. 22, 2020; 6 pages.
 Japanese Application No. 2020-11176 filed Jun. 5, 2020; Notice of Allowance dated Sep. 2, 2020; 6 pages.
 U.S. Appl. No. 29/694,049, filed Jun. 6, 2019; Restriction Requirement dated Jul. 29, 2020; 62 pages.
 U.S. Appl. No. 29/694,050, filed Jun. 6, 2019; Notice of Allowance dated Jul. 29, 2020; 40 pages.
 U.S. Appl. No. 29/740,552, filed Jul. 6, 2020; Restriction Requirement dated Oct. 2, 2020; 8 pages.
 U.S. Appl. No. 29/740,562, filed Jul. 6, 2020; Restriction Requirement dated Oct. 2, 2020; 8 pages.
 Written Opinion for International Application No. PCT/US2020/021728; International Filing Date: Mar. 9, 2020; dated Jul. 16, 2020; 10 pages.
 Written Opinion for International Application No. PCT/US2020/037484; International Filing Date: Jun. 12, 2020; dated Sep. 22, 2020; 8 pages.
 Amazon.com; “Vitamix Con A3300 Ascent Series Smart Blender”; Available on amazon.com Jan. 5, 2017; (Year: 2017); <https://www.amazon.com/dp/B01MT67Z7B/>; 1 page.
 U.S. Appl. No. 29/694,050, filed Jun. 6, 2019; Notice of Allowance dated Oct. 29, 2020; 15 pages.
 U.S. Appl. No. 29/740,272, filed Jul. 2, 2020; Restriction Requirement dated Nov. 25, 2020; 7 pages.
 U.S. Appl. No. 29/694,051, filed Jun. 6, 2019; Restriction Requirement dated Dec. 15, 2020; 62 pages.

* cited by examiner

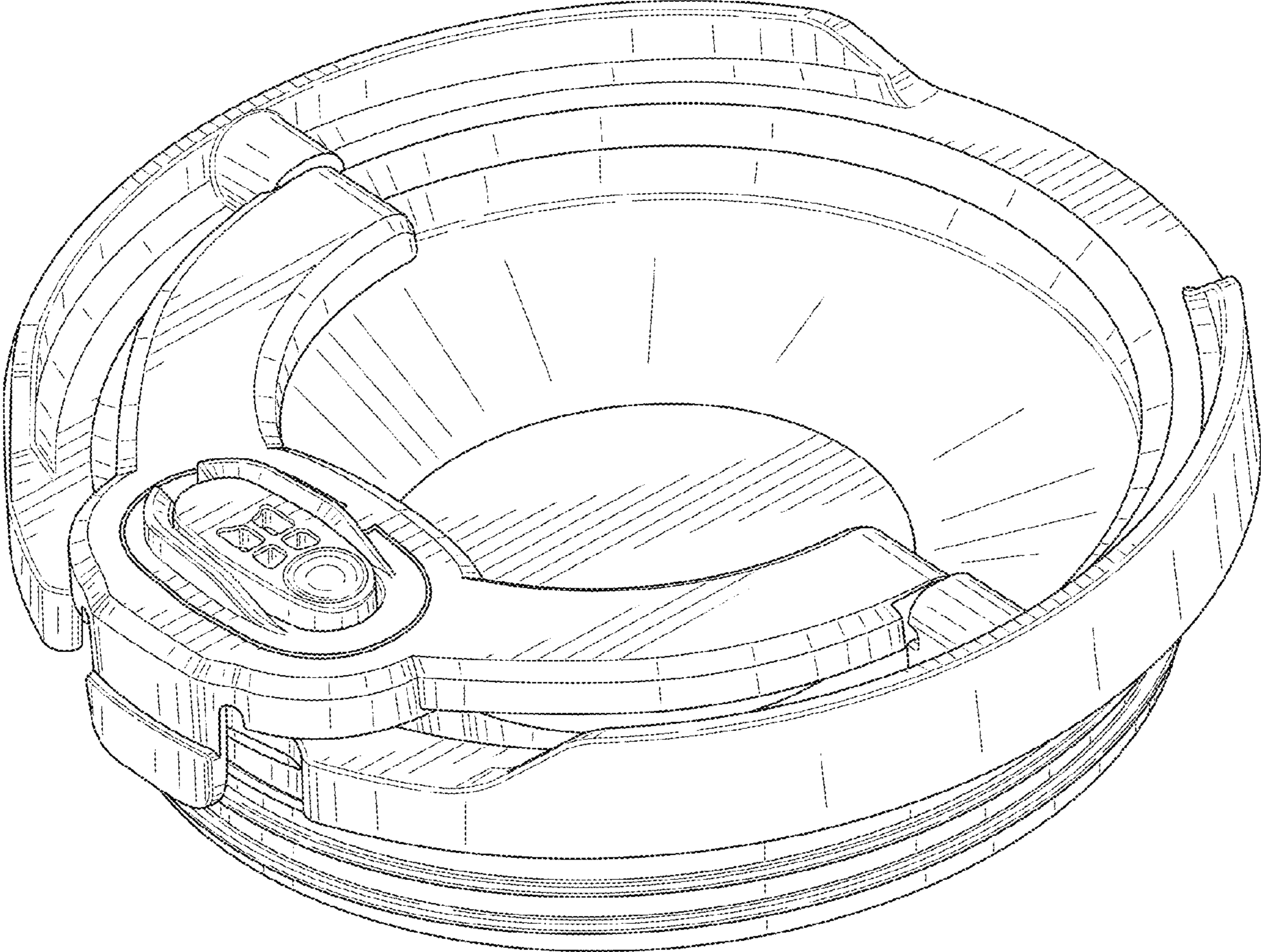

FIG. 1

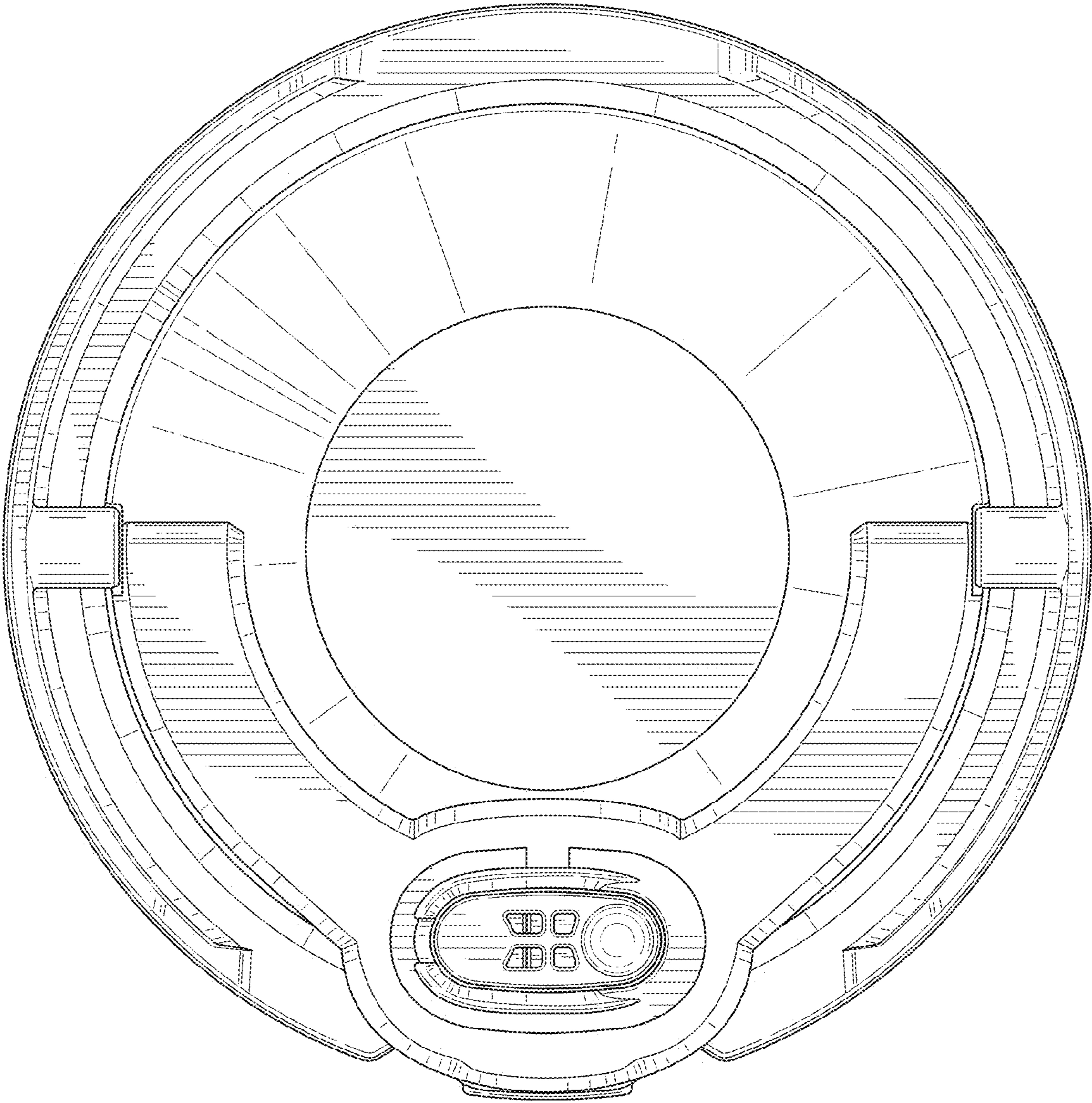

FIG. 2

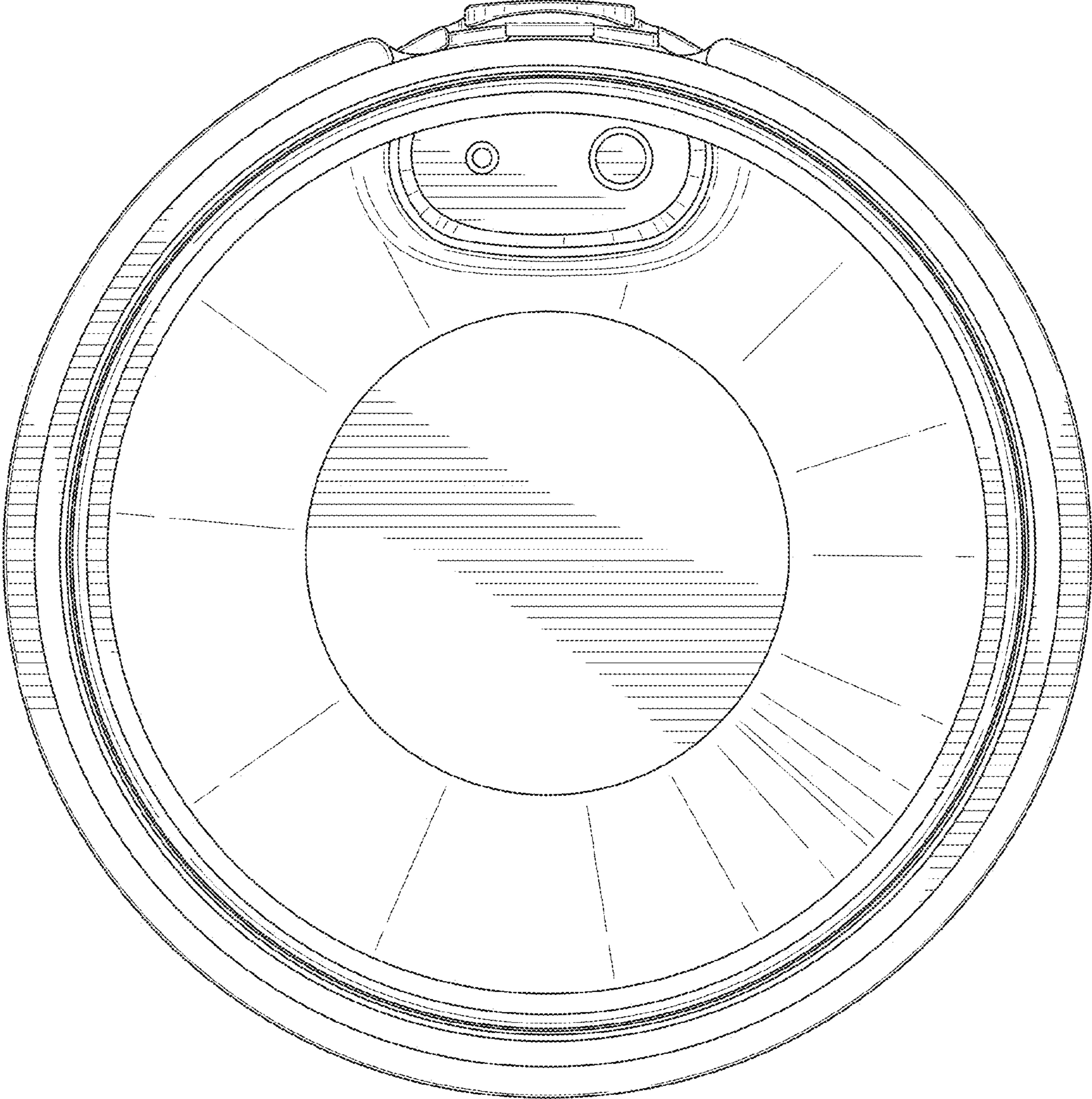

FIG. 3

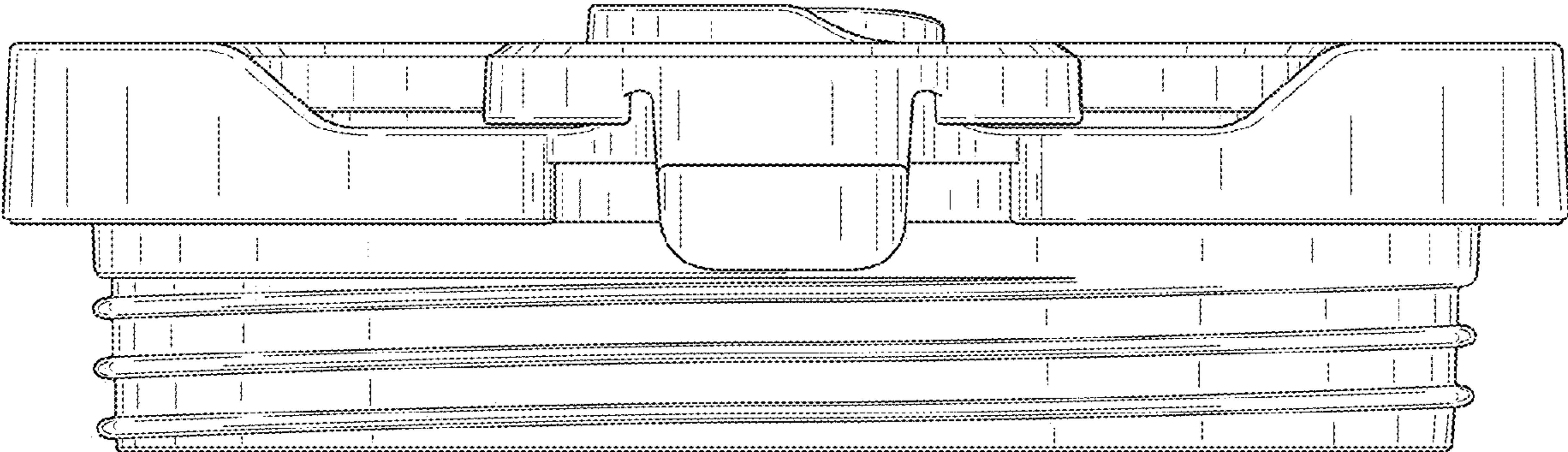

FIG. 4

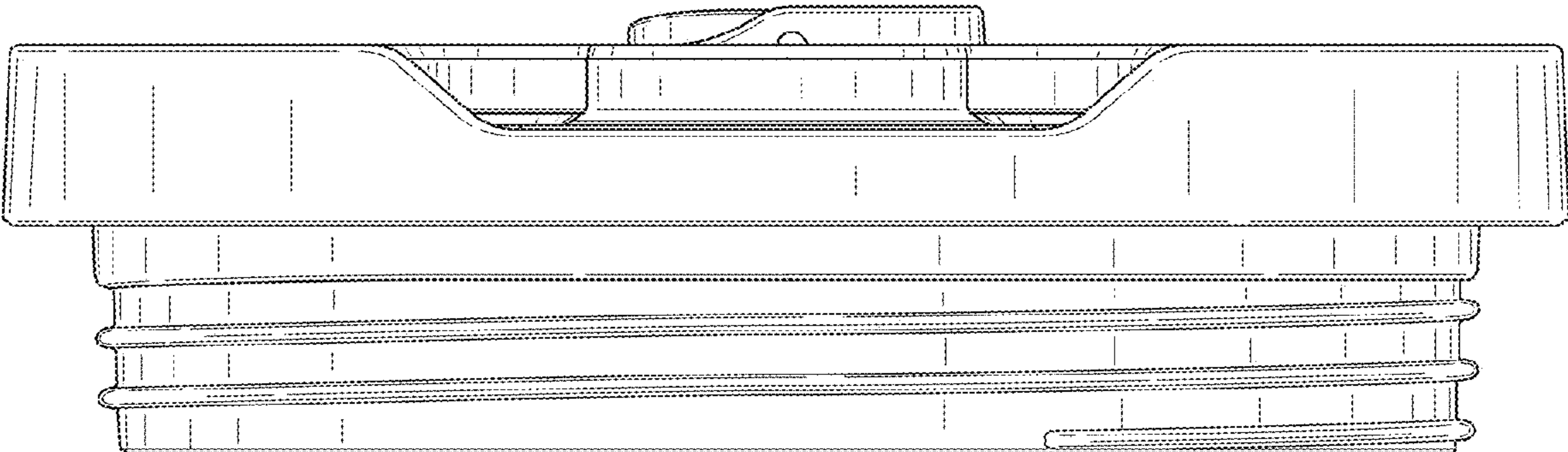

FIG. 5

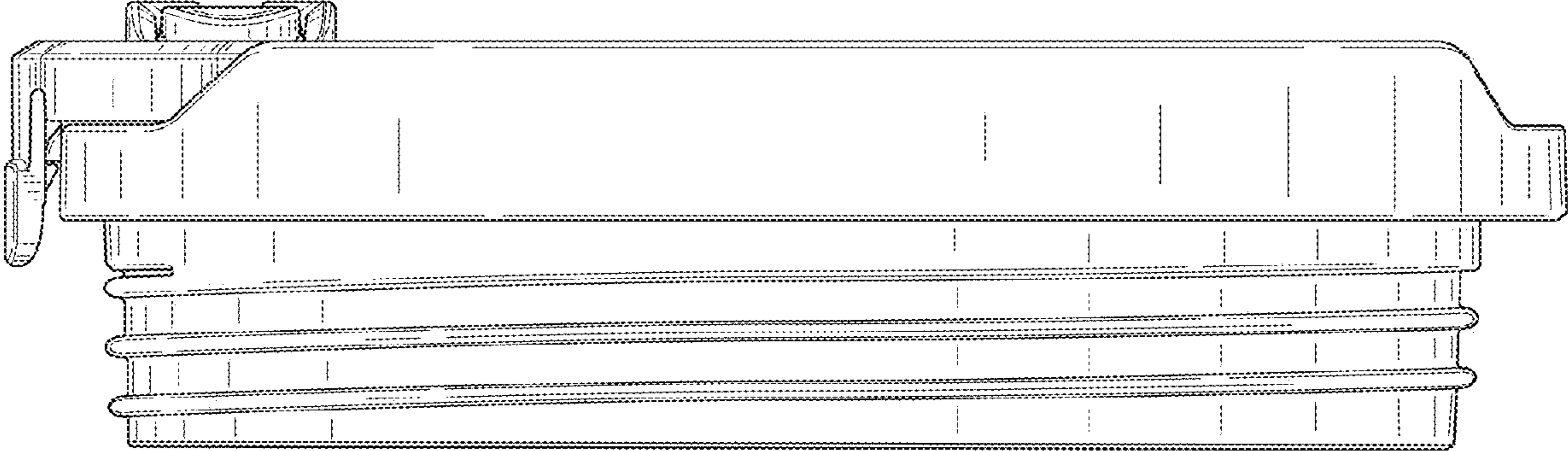

FIG. 6

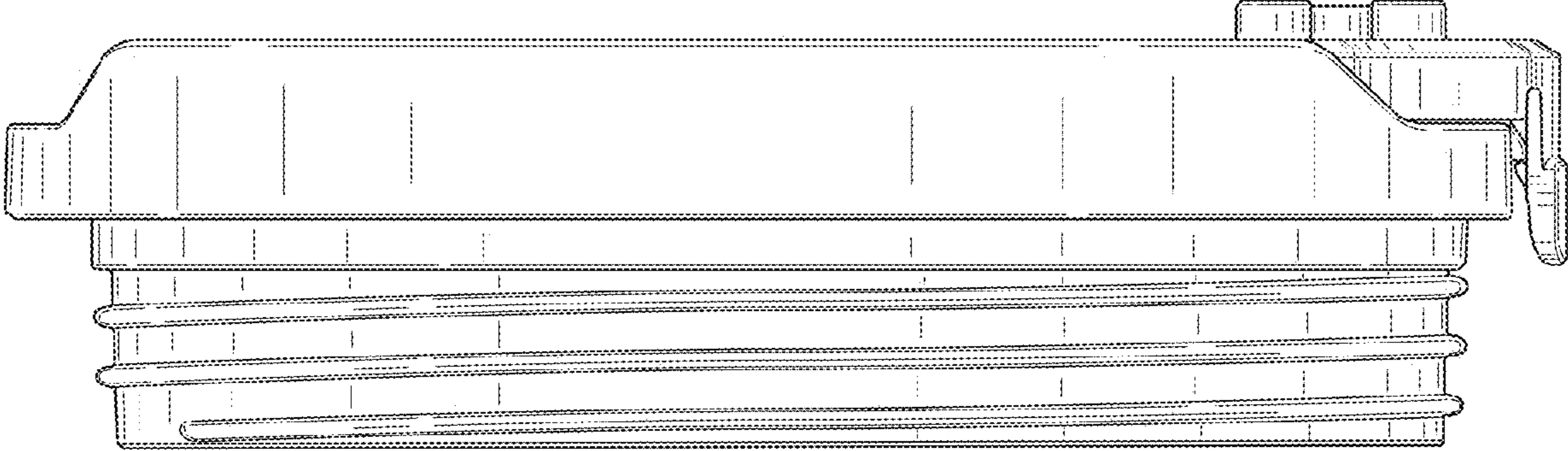

FIG. 7