



US00D940356S

(12) **United States Design Patent**  
**Chen et al.**

(10) **Patent No.:** **US D940,356 S**

(45) **Date of Patent:** **\*\* Jan. 4, 2022**

(54) **LAMP**

D531,741 S \* 11/2006 Takahashi ..... D26/2  
D553,267 S \* 10/2007 Yuen ..... D26/2  
D696,798 S \* 12/2013 Masashi ..... D26/2

(71) Applicant: **Phoenix Contact Asia-Pacific (Nanjing) Co., Ltd.**, Nanjing (CN)

\* cited by examiner

(72) Inventors: **Lei Chen**, Nanjing (CN); **Jinge Liu**, Nanjing (CN)

*Primary Examiner* — Marcus A Jackson

(74) *Attorney, Agent, or Firm* — Burriss Law, PLLC

(73) Assignee: **Phoenix Contact Asia-Pacific (Nanjing) Co., Ltd.**, Nanjing (CN)

(\*\*) Term: **15 Years**

(57) **CLAIM**

(21) Appl. No.: **29/739,365**

The ornamental design for an lamp, as shown and described.

(22) Filed: **Aug. 31, 2020**

(30) **Foreign Application Priority Data**

**DESCRIPTION**

Dec. 24, 2019 (CN) ..... 201930722068.4

(51) **LOC (13) Cl.** ..... **26-04**

(52) **U.S. Cl.**  
USPC ..... **D26/2**

(58) **Field of Classification Search**  
USPC ..... D26/1-4  
CPC ..... H01R 5/00; H01R 13/46; H01R 13/514;  
H01R 31/02; H01R 31/048; H01J 5/00;  
H01J 5/16; H01J 1/02; H01J 15/00; H01J  
5/48; H01J 5/50; H01J 19/54; F21V 5/00;  
F21K 9/00; F21K 13/00

See application file for complete search history.

The patent or application file contains at least one drawing executed in color. Copies of this patent or patent application publication with color drawing(s) will be provided by the Office upon request and payment of the necessary fee.  
FIG. 1 is a perspective view of a first embodiment of the lamp with a claim to the color green as shown;  
FIG. 2 is left side view thereof;  
FIG. 3 is a bottom view thereof;  
FIG. 4 is right side view thereof;  
FIG. 5 is a top view thereof;  
FIG. 6 is a perspective view of a second embodiment of the lamp with no claim to color;  
FIG. 7 is left side view thereof;  
FIG. 8 is a bottom view thereof;  
FIG. 9 is right side view thereof; and,  
FIG. 10 is a top view thereof.

(56) **References Cited**

**U.S. PATENT DOCUMENTS**

D508,575 S \* 8/2005 Buschmann ..... D26/2  
D528,227 S \* 9/2006 Chou ..... D26/2

**1 Claim, 10 Drawing Sheets**  
**(5 of 10 Drawing Sheet(s) Filed in Color)**





FIG. 1

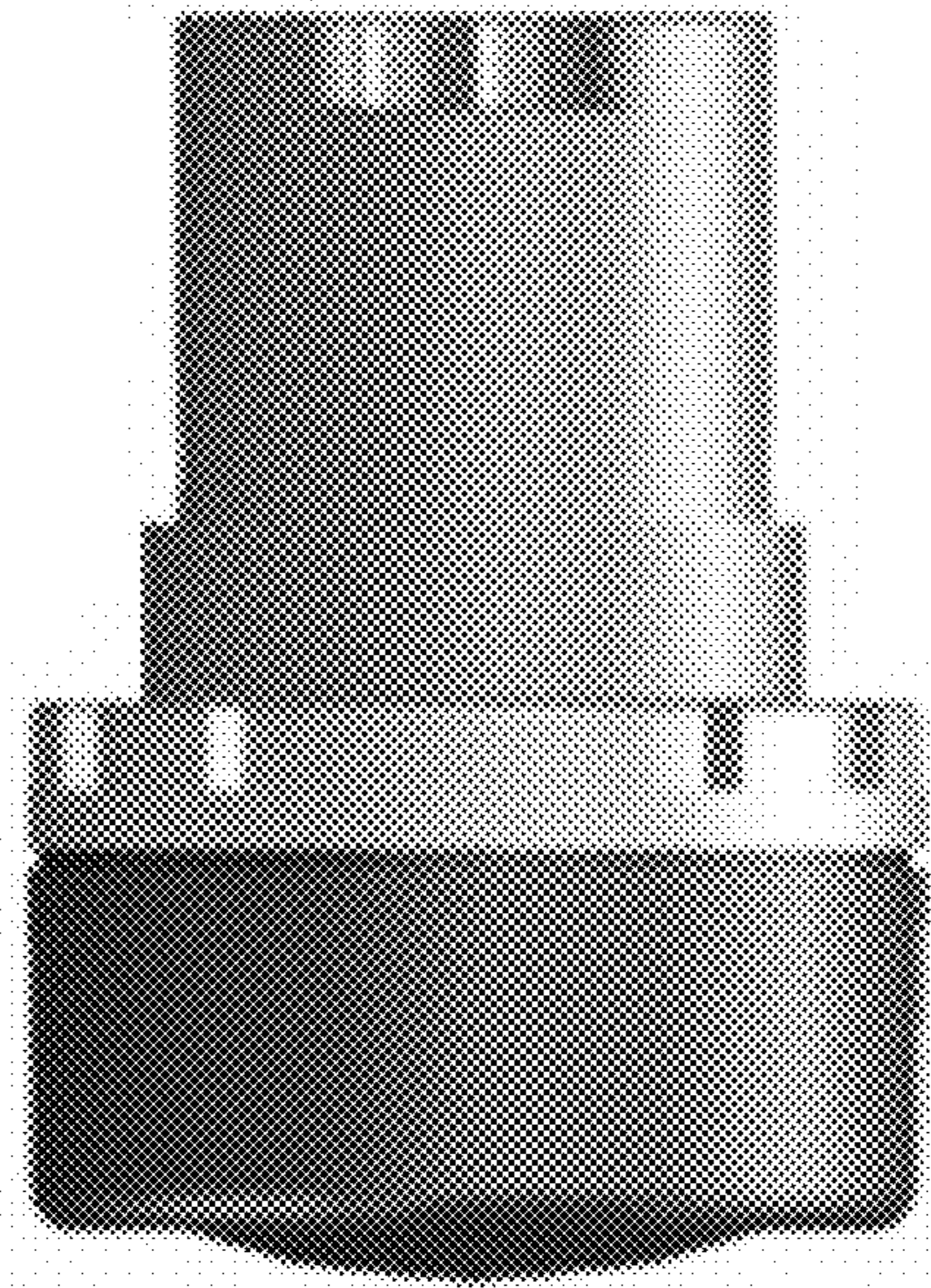

FIG. 2

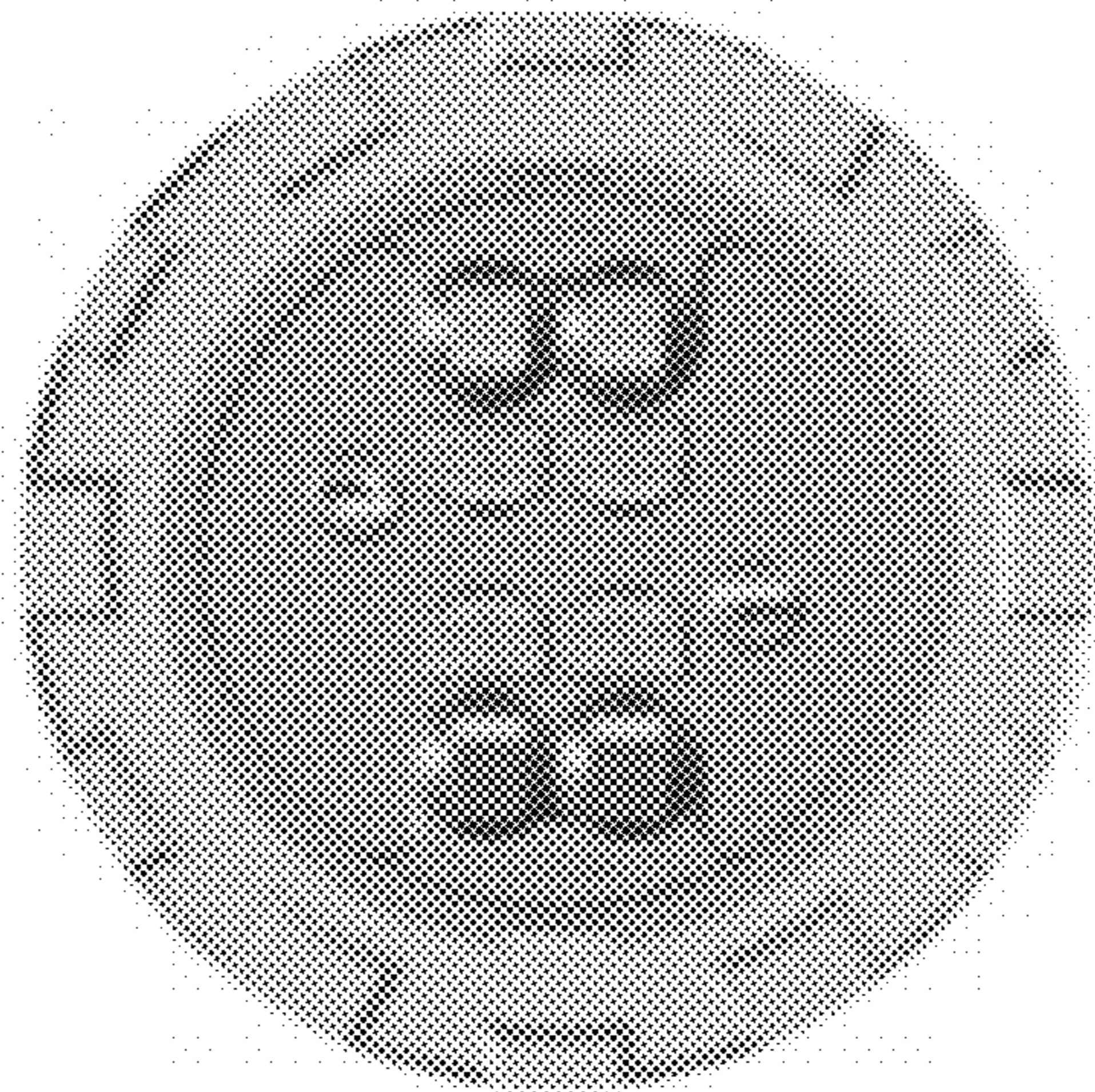

FIG. 3

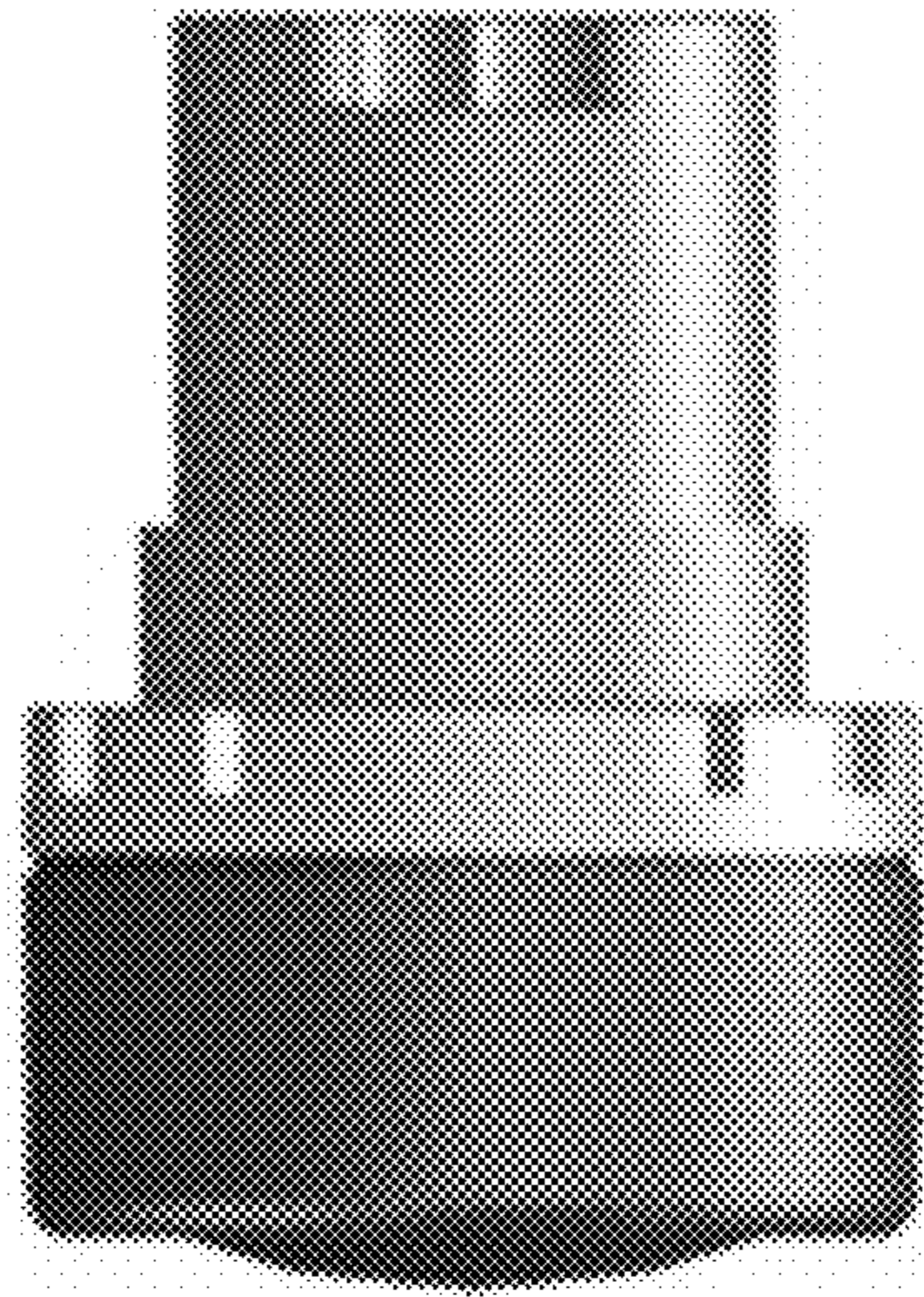

FIG. 4

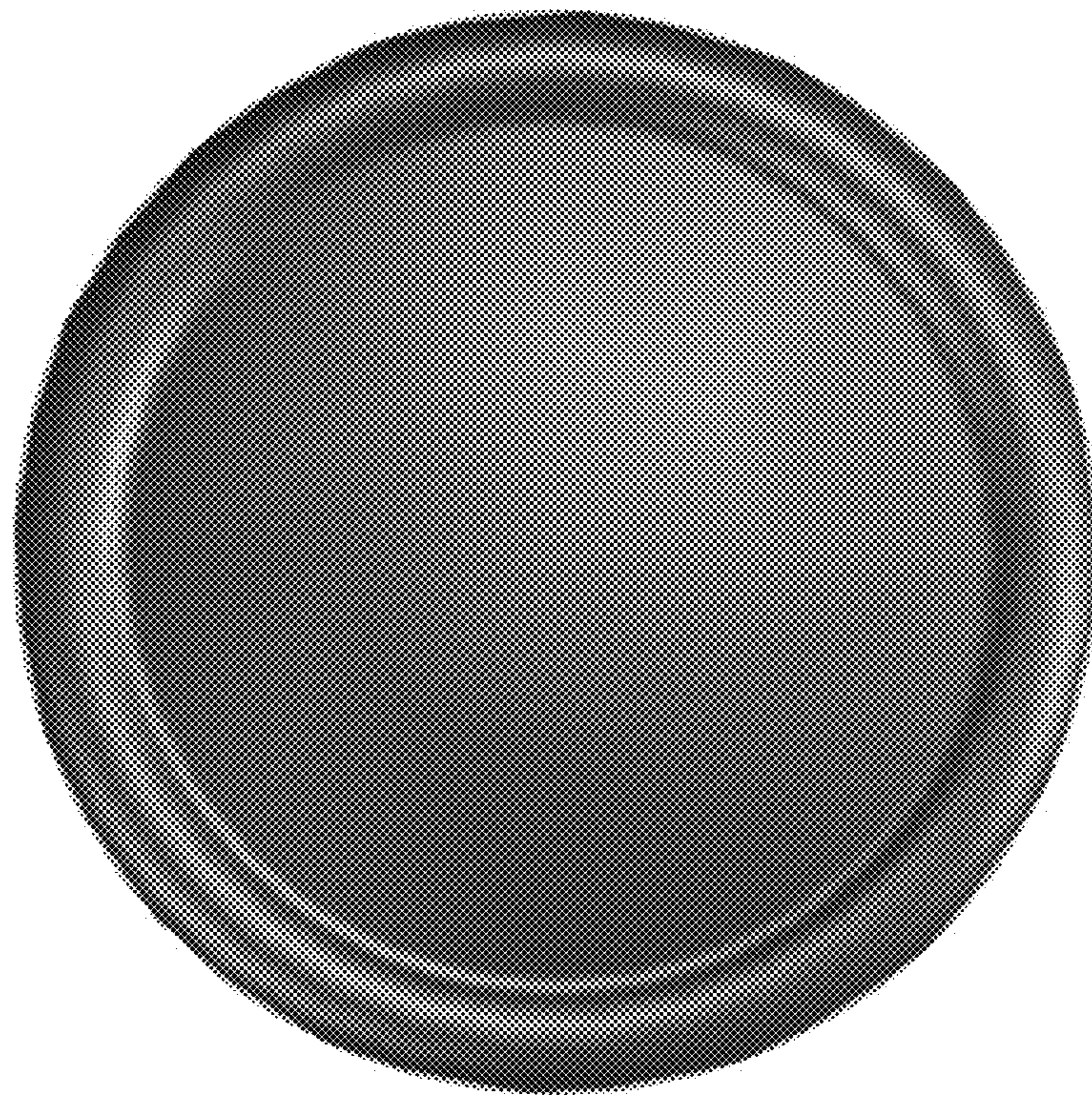

FIG. 5



FIG. 6



FIG. 7



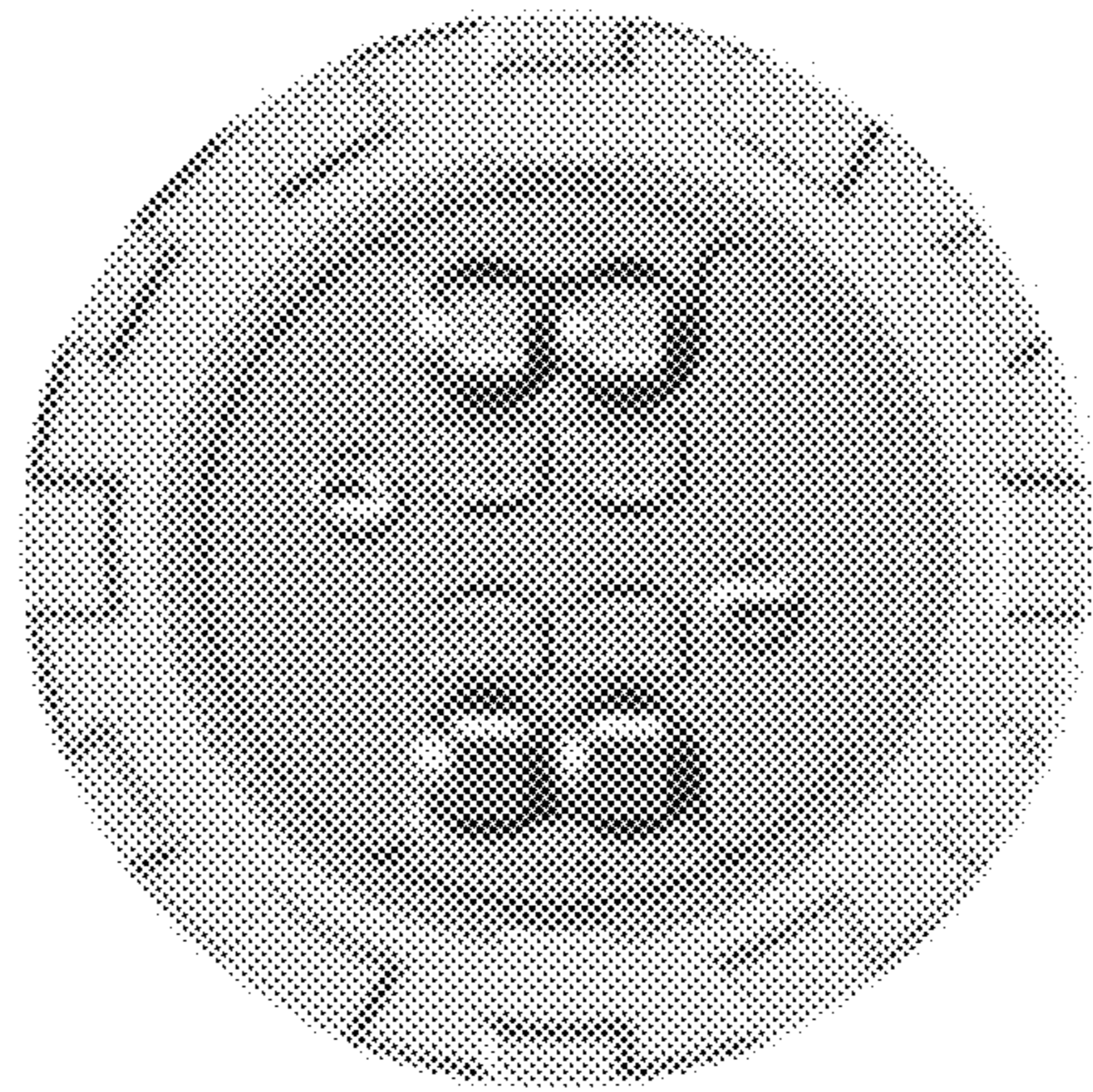

FIG. 8



FIG. 9

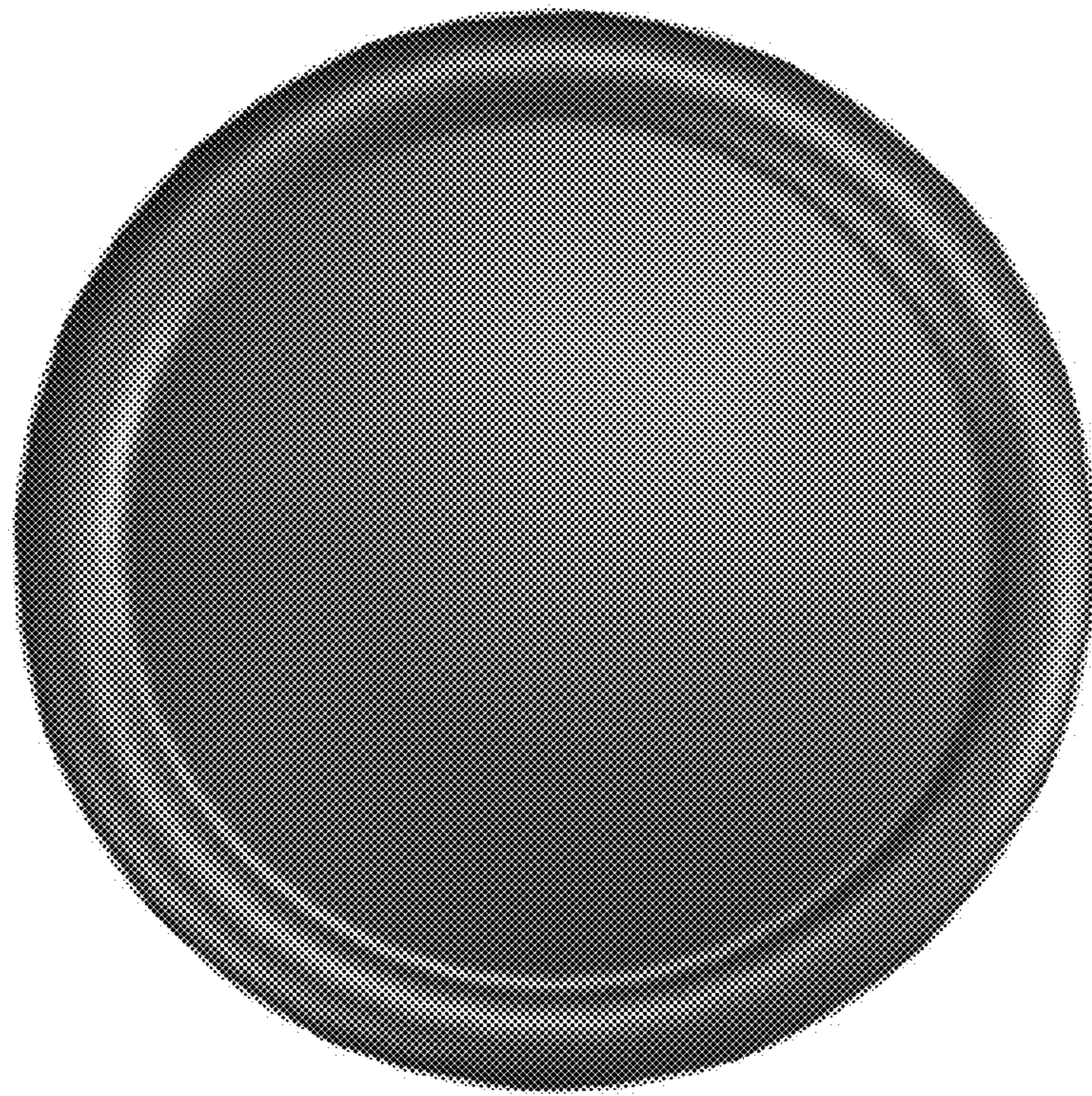

FIG. 10