



US00D939980S

(12) **United States Design Patent** (10) **Patent No.:** **US D939,980 S**  
**Barton et al.** (45) **Date of Patent:** **\*\* Jan. 4, 2022**

- (54) **DATA AND SENSOR SYSTEM HUB** 3,796,208 A 3/1974 Bloice  
 3,953,843 A 4/1976 Codina  
 3,969,712 A 7/1976 Butman et al.  
 4,337,527 A 6/1982 Delagrange et al.  
 4,510,487 A 4/1985 Wolfe et al.  
 4,639,902 A 1/1987 Leverance et al.  
 4,747,085 A 5/1988 Dunegan et al.  
 4,775,854 A 10/1988 Cottrell  
 4,779,095 A 10/1988 Guerreri  
 D312,219 S \* 11/1990 Pratt ..... D10/101  
 4,971,283 A 11/1990 Tilsner  
 5,043,705 A 8/1991 Rooz et al.  
 5,142,508 A 8/1992 Mitchell et al.  
 5,146,208 A 9/1992 Parra  
 5,195,060 A 3/1993 Roll  
 5,200,931 A 4/1993 Kosalos et al.  
 5,369,623 A 11/1994 Zerangue  
 5,574,497 A 11/1996 Henderson et al.  
 5,616,239 A 4/1997 Wendell et al.  
 5,631,976 A 5/1997 Bolle et al.  
 5,691,777 A 11/1997 Kassatly  
 6,133,838 A 10/2000 Meniere  
 6,173,066 B1 1/2001 Peurach et al.  
 6,421,463 B1 7/2002 Poggio et al.  
 6,570,608 B1 5/2003 Tserng  
 6,628,835 B1 9/2003 Brill et al.  
 D733,596 S \* 7/2015 Goodner ..... D10/70  
 9,443,207 B2 9/2016 Przybylko et al.  
 9,972,188 B2 5/2018 AlMahmoud  
 2009/0189981 A1 7/2009 Siann et al.  
 2012/0269399 A1 10/2012 Anderson et al.  
 2014/0267736 A1 9/2014 Delean  
 2014/0333775 A1 11/2014 Naikal et al.  
 2015/0107015 A1 4/2015 Ng  
 2015/0139485 A1 5/2015 Bourdev  
 2016/0104359 A1 4/2016 AlMahmoud  
 2019/0004169 A1 1/2019 Watkins et al.
- (71) Applicants: **Chris Barton**, San Francisco, CA (US);  
**Nichole Suzanne Rouillac**, San Francisco, CA (US); **Robin Nicholas Hubbard**, San Francisco, CA (US);  
**Jonathan Chei-Feung Lau**, San Francisco, CA (US)
- (72) Inventors: **Chris Barton**, San Francisco, CA (US);  
**Nichole Suzanne Rouillac**, San Francisco, CA (US); **Robin Nicholas Hubbard**, San Francisco, CA (US);  
**Jonathan Chei-Feung Lau**, San Francisco, CA (US)
- (73) Assignee: **Guard, Inc.**, San Francisco, CA (US)
- (\*\*) Term: **15 Years**
- (21) Appl. No.: **29/704,836**
- (22) Filed: **Sep. 6, 2019**

**Related U.S. Application Data**

- (63) Continuation of application No. 16/443,866, filed on Jun. 17, 2019.
- (51) **LOC (13) Cl.** ..... **10-04**
- (52) **U.S. Cl.**  
 USPC ..... **D10/70; D10/101**
- (58) **Field of Classification Search**  
 USPC ..... D10/70, 101  
 CPC .. G06T 7/20; G06T 7/80; G06T 7/521; G06T 7/70; G06T 2207/10052; G06T 2207/30196; G06T 17/05; G06N 3/08; G08B 21/08; G08B 21/086; G01S 17/89; A63F 13/213  
 See application file for complete search history.

**References Cited**

**U.S. PATENT DOCUMENTS**

- 2,783,459 A 2/1957 Lienau et al.  
 3,732,556 A 5/1973 Caprillo et al.

**FOREIGN PATENT DOCUMENTS**

- BR 9408257 A 12/1996  
 CA 2436964 A1 6/2002  
 CN 103413114 A 11/2013  
 EP 0485735 A1 5/1992  
 EP 0261917 B1 3/1994  
 FR 2741370 A1 5/1997  
 FR 2763459 A1 11/1998  
 GB 541637 A 12/1941  
 GB 2254215 A 9/1992  
 JP S62251879 A 11/1987  
 JP H05157529 A 6/1993  
 JP H1070654 A 3/1998  
 JP 3196842 B2 8/2001

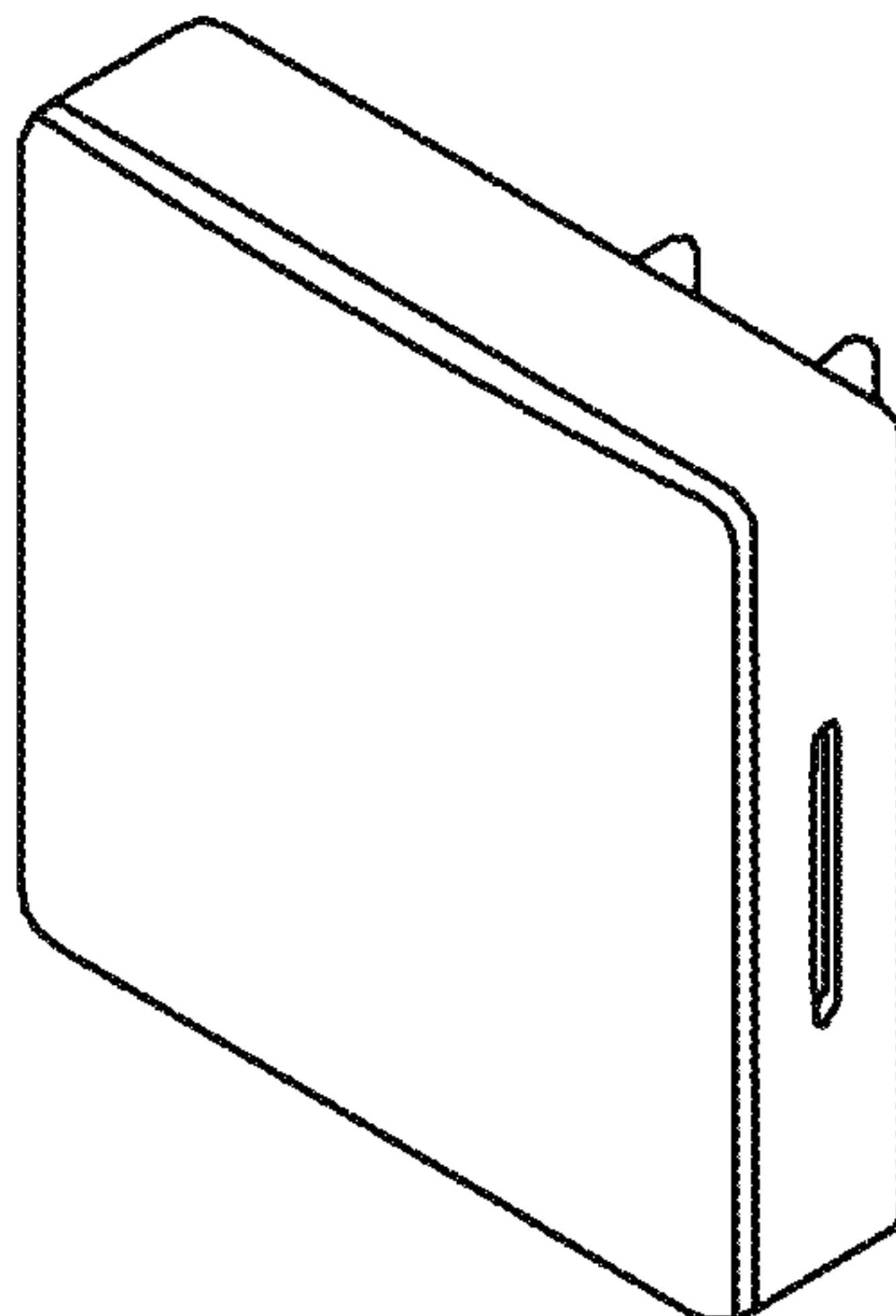



JP	3264121 B2	3/2002
WO	1995034056	12/1995
WO	2017130187 A1	8/2017

## OTHER PUBLICATIONS

Baqué, Pierre et al. "Deep Occlusion Reasoning for Multi-camera Multi-target Detection." 2017 IEEE International Conference on Computer Vision (ICCV) (2017): 271-279.

Brubaker, Marcus A., Leonid Sigal and David J. Fleet, "Video-Based People Tracking," Handbook of Ambient Intelligence and Smart Environments, pp. 57-87, Springer, Boston, MA (2009).

Cao, Zhe, Thomas Simon, Shih-En Wei, Yaser Sheikh, "Realtime Multi-Person 2D Pose Estimation Using Part Affinity Fields," Proceedings of the IEEE Conference on Computer Vision and Pattern Recognition (2017), pp. 7291-7299.

Centers for Disease Control and Prevention, National Center for Injury Prevention and Control. Web-based Injury Statistics Query and Reporting System (WISQARS) [online], [cited May 3, 2012]. Available from: URL: <http://www.cdc.gov/injury/wisqars>.

Chen, Liang-Chieh et al. "Semantic Image Segmentation with Deep Convolutional Nets and Fully Connected CRFs." CoRR abs/1412.7062 (2014): n. pag.

Fleuret, François et al. "Multicamera People Tracking with a Probabilistic Occupancy Map." IEEE Transactions on Pattern Analysis and Machine Intelligence 30 (2008): 267-282.

Greif, Thomas, "A Probabilistic Motion Model for Swimmers: A Computer Vision Approach," Master of Science Thesis, Universität Augsburg (2009).

Grundmann, Matthias, "Computational video: post-processing methods for stabilization, retargeting and segmentation," Thesis for Degree of Doctor of Philosophy in the School of Interactive Computing, Georgia Institute of Technology, May 2013 (195 pages).

Güler, Riza Alp et al. "DensePose: Dense Human Pose Estimation in the Wild." 2018 IEEE/CVF Conference on Computer Vision and Pattern Recognition (2018): 7297-7306.

Hartley, Richard and Andrew Zisserman, "Multiple View Geometry in Computer Vision," Second Edition, Cambridge University Press, Mar. 2004.

He, Kaiming, Georgia Gkioxari, Piotr Dollár and Ross B. Girshick. "Mask R-CNN." 2017 IEEE International Conference on Computer Vision (ICCV) (2017), pp. 2980-2988.

Jialue Fan, Wei Xu, Ying Wu, Yihong Gong, "Human Tracking Using Convolutional Neural Networks," IEEE Transactions on Neural Networks, vol. 21, No. 10, Oct. 2010.

Joshi, Neel, Shai Avidan, Wojciech Matusik, David J. Kriegman, "Synthetic Aperture Tracking: Tracking through Occlusions," IEEE 11th International Conference on Computer Vision, Oct. 14-21, 2007, pp. 1-8.

Liu, Xiaobai, "Multi-View 3D Human Tracking in Crowded Scenes," Proceedings of the Thirtieth AAAI Conference on Artificial Intelligence (AAAI-16), 2016.

Pentair IntelliLevel Water Leveling Monitoring, Installation and User's Guide, Pentair PLC, 2019 Retrieved Online.

Schechner, Y. Y. and Nir Karpel. "Attenuating natural flicker patterns." Oceans '04 MTS/IEEE Techno-Ocean '04 (IEEE Cat. No. 04CH37600) 3 (2004): 1262-1268 vol. 3.

Schechner, Yoav Y. and Nir Karpel. "Clear underwater vision." Proceedings of the 2004 IEEE Computer Society Conference on Computer Vision and Pattern Recognition, 2004. CVPR 2004. 1 (2004): I-I.

Schechner, Yoav Y. et al. "Polarization and statistical analysis of scenes containing a semireflector." Journal of the Optical Society of America. A, Optics, image science, and vision 17 2 (2000): 276-84.

Shah, Sohil Atul and Vladlen Koltun. "Robust continuous clustering." Proceedings of the National Academy of Sciences of the United States of America 114 37 (2017): 9814-9819.

Shu, Guang, "Human Detection, Tracking and Segmentation in Surveillance Video," PhD Thesis, University of Central Florida, 2014.

Swirski, Yohay and Yoav Y. Schechner. "3Deflicker from motion." IEEE International Conference on Computational Photography (ICCP) (2013): 1-9.

Swirski, Yohay et al. "Stereo from flickering caustics." 2009 IEEE 12th International Conference on Computer Vision (2009): 205-212.

Tian, Luchao, Mingchen Li, Guyue Zhang, Jingwen Zhao and Yan Qiu Chen. "Robust Human Detection With Super-Pixel Segmentation and Random Ferns Classification Using RGB-D Camera." 2017 IEEE International Conference on Multimedia and Expo (ICME) (2017), pp. 1542-1547.

Tian, Yuandong and Srinivasa G. Narasimhan. "Globally Optimal Estimation of Nonrigid Image Distortion." International Journal of Computer Vision 98 (2011): 279-302.

Tian, Yuandong and Srinivasa G. Narasimhan. "Theory and Practice of Hierarchical Data-driven Descent for Optimal Deformation Estimation." International Journal of Computer Vision 115 (2015): 44-67.

Tzeng, Eric et al. "Simultaneous Deep Transfer Across Domains and Tasks." 2015 IEEE International Conference on Computer Vision (ICCV) (2015): 4068-4076.

Vo, Minh et al. "Automatic Adaptation of Person Association for Multiview Tracking in Group Activities." ArXiv abs/1805.08717 (2018): 17 pages.

Vo, Minh et al. "Spatiotemporal Bundle Adjustment for Dynamic 3D Reconstruction." 2016 IEEE Conference on Computer Vision and Pattern Recognition (CVPR) (2016): 1710-1718.

Wang, Jian et al., "Programmable Triangulation Light Curtains," European Conference on Computer Vision (ECCV), 2018, pp. 19-34.

Wang, Jiayuan, "Liquid Level Sensing Using Capacitive-to-Digital Converters," Analog Dialogue, vol. 49, Apr. 2015. Retrieved Online. Wikipedia contributors, "Scheimpflug principle," Wikipedia, The Free Encyclopedia, [https://en.wikipedia.org/w/index.php?title=Scheimpflug\\_principle&oldid=910381418](https://en.wikipedia.org/w/index.php?title=Scheimpflug_principle&oldid=910381418) (accessed Sep. 24, 2019). Wikipedia contributors, "Tilt-shift photography," Wikipedia, The Free Encyclopedia, (accessed Sep. 24, 2019).

Wu, Changchang, "VisualSFM: A Visual Structure from Motion System," Retrieved online Sep. 23, 2019, URL: (2011).

Yang, Tao, Yanning Zhang, Jingyi Yu, Jing Li, Wenguang Ma, Xiaomin Tong, Rui Yu and Lingyan Ran. "All-in-Focus Synthetic Aperture Imaging." ECCV (Sep. 2014), pp. 1-15.

Zhi, Tiancheng et al. "Deep Material-Aware Cross-Spectral Stereo Matching." 2018 IEEE/CVF Conference on Computer Vision and Pattern Recognition (2018): 1916-1925.

\* cited by examiner

*Primary Examiner* — Antoine Duval Davis

(74) *Attorney, Agent, or Firm* — Kokka & Backus, PC

(57)

## CLAIM

An ornamental design for a data and sensor system hub, as shown and described.

## DESCRIPTION

FIG. 1 is a front perspective view of a data and sensor system hub according to our new design;

FIG. 2 is a front view of a data and sensor system hub thereof;

FIG. 3 is a rear view of a data and sensor system hub thereof;

FIG. 4 is a right side view of a data and sensor system hub thereof;

FIG. 5 is a left side view of a data and sensor system hub thereof;

FIG. 6 is a top view of a data and sensor system hub thereof; and,

FIG. 7 is a bottom view of a data and sensor system hub thereof.

**1 Claim, 7 Drawing Sheets**

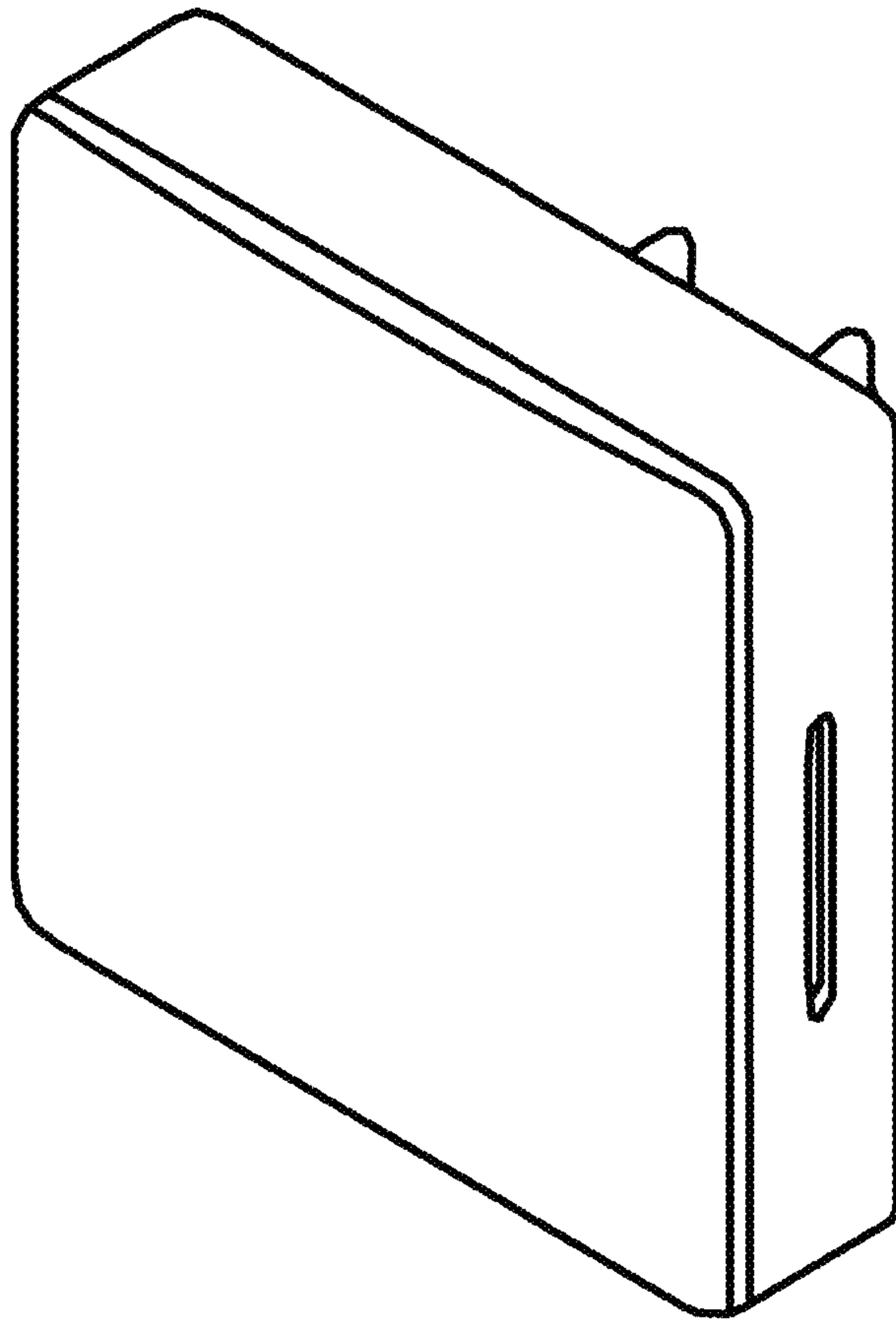

FIG. 1

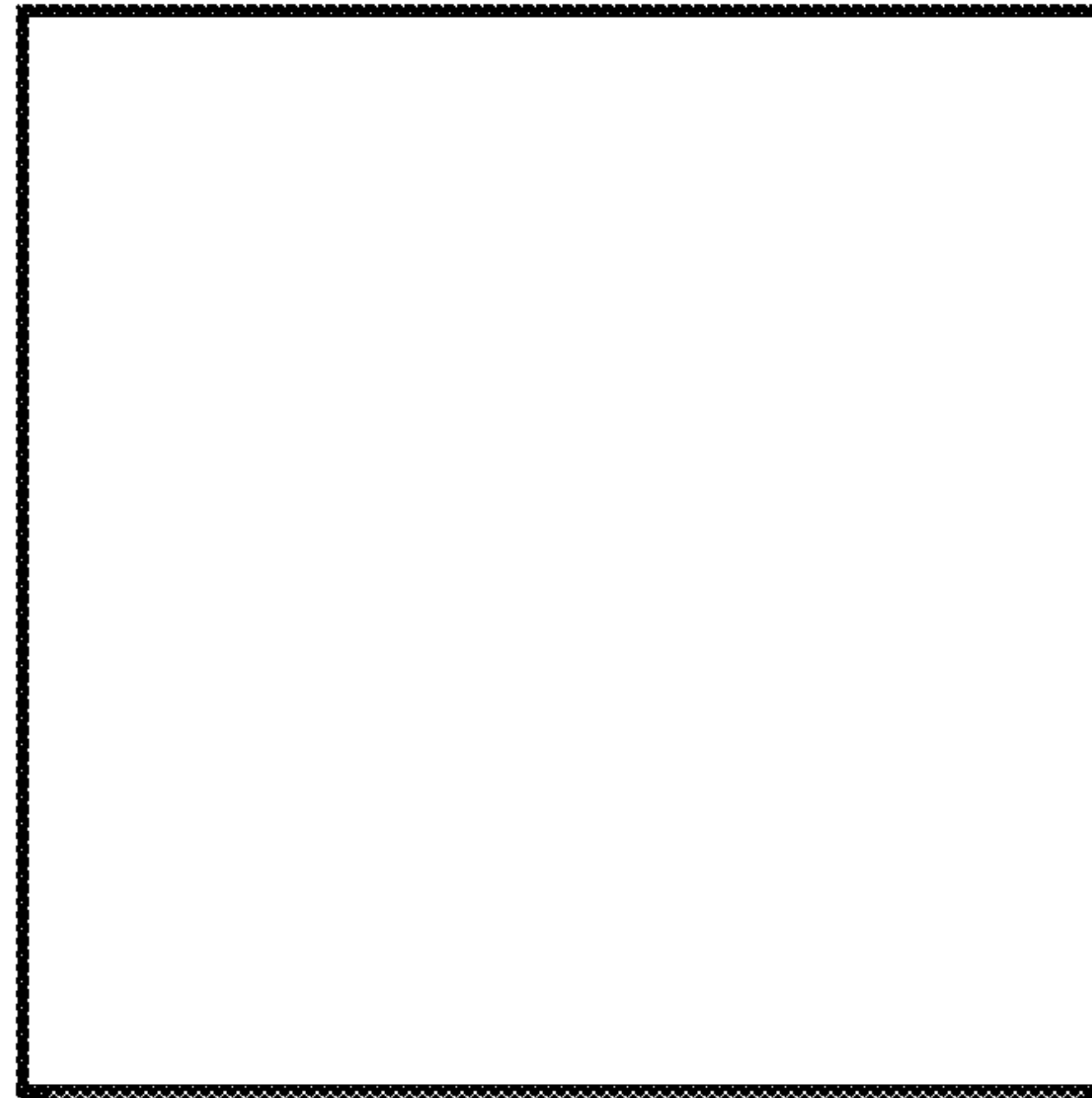

FIG. 2

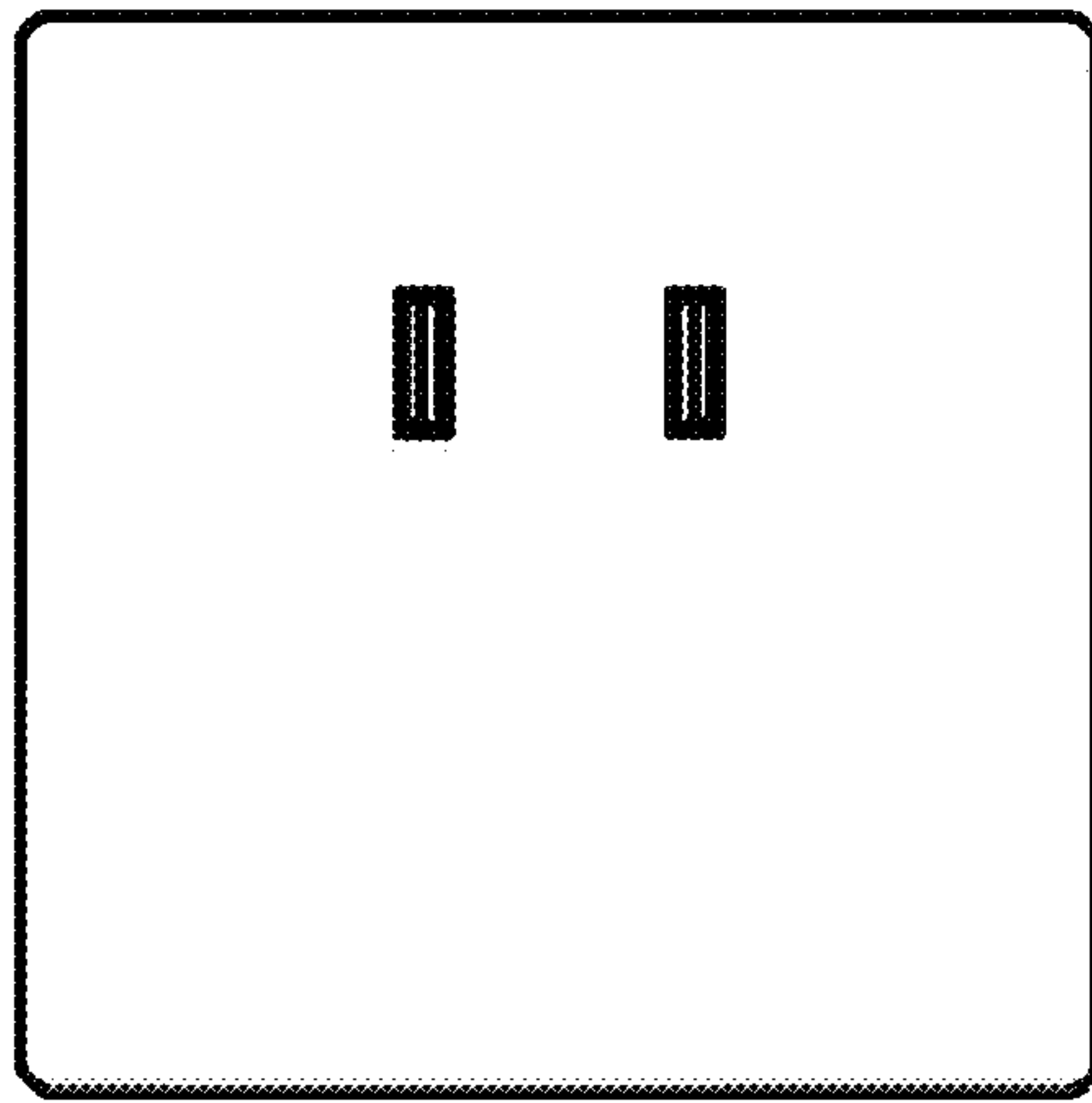

FIG. 3

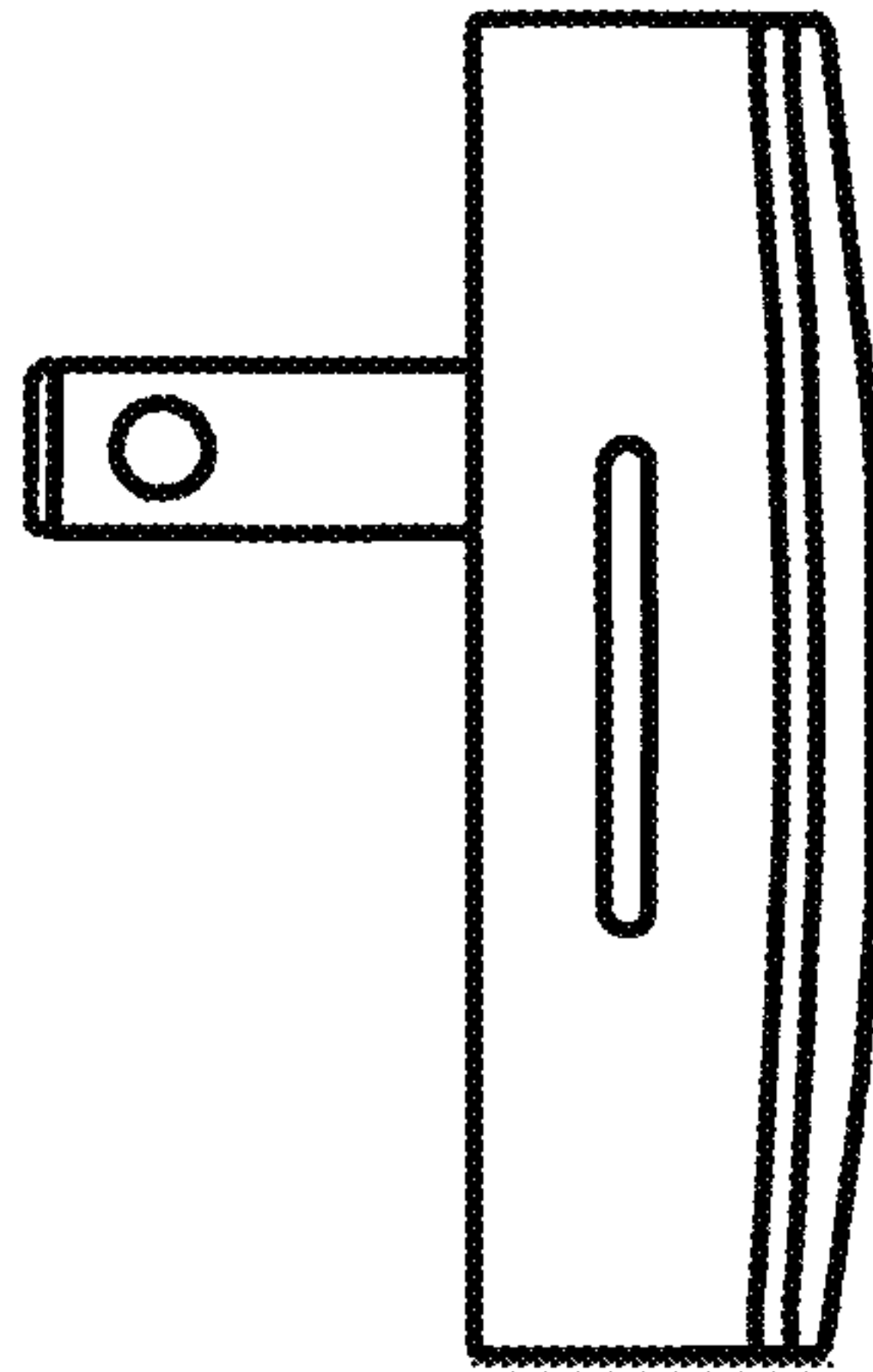

FIG.4



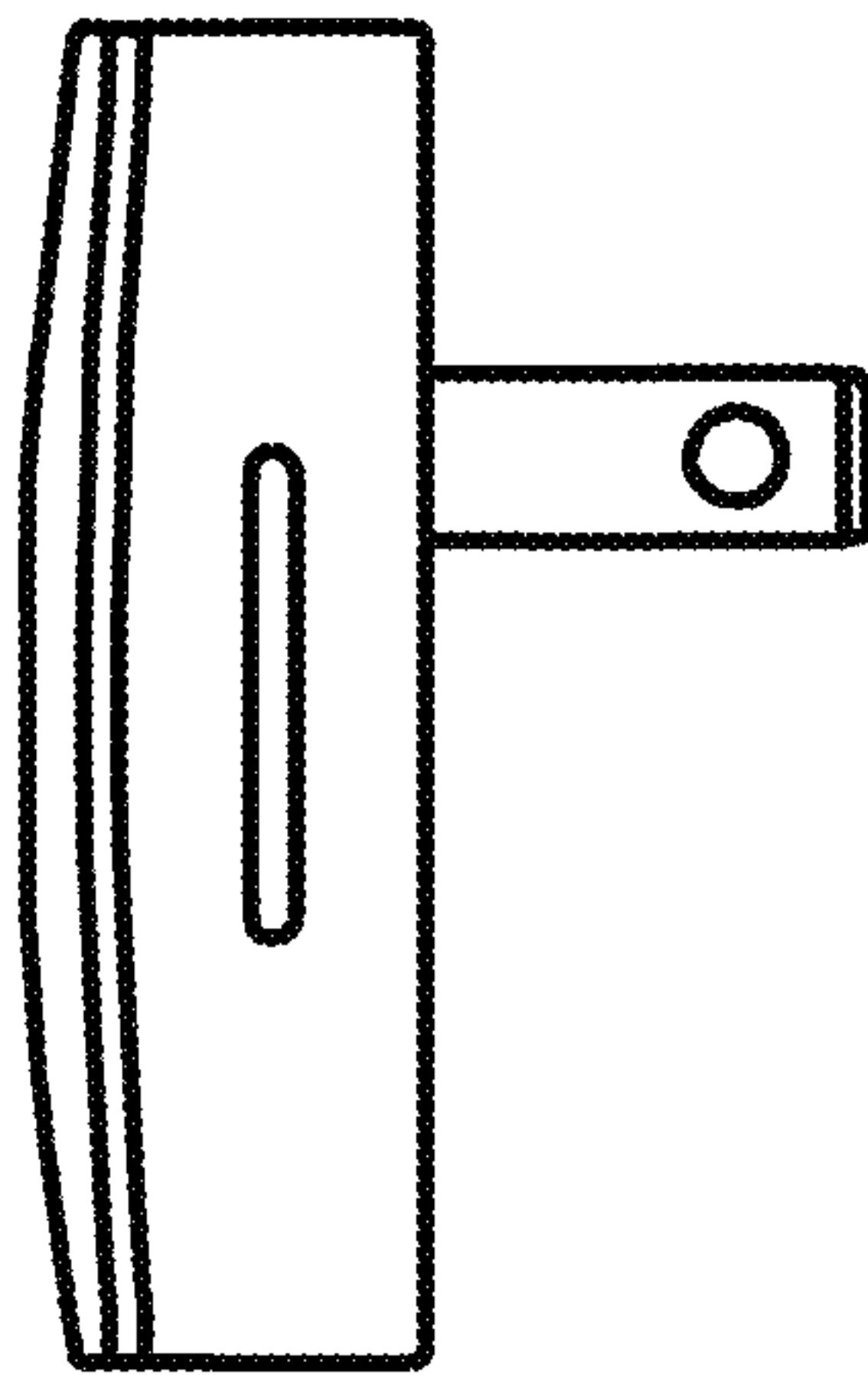

FIG.5



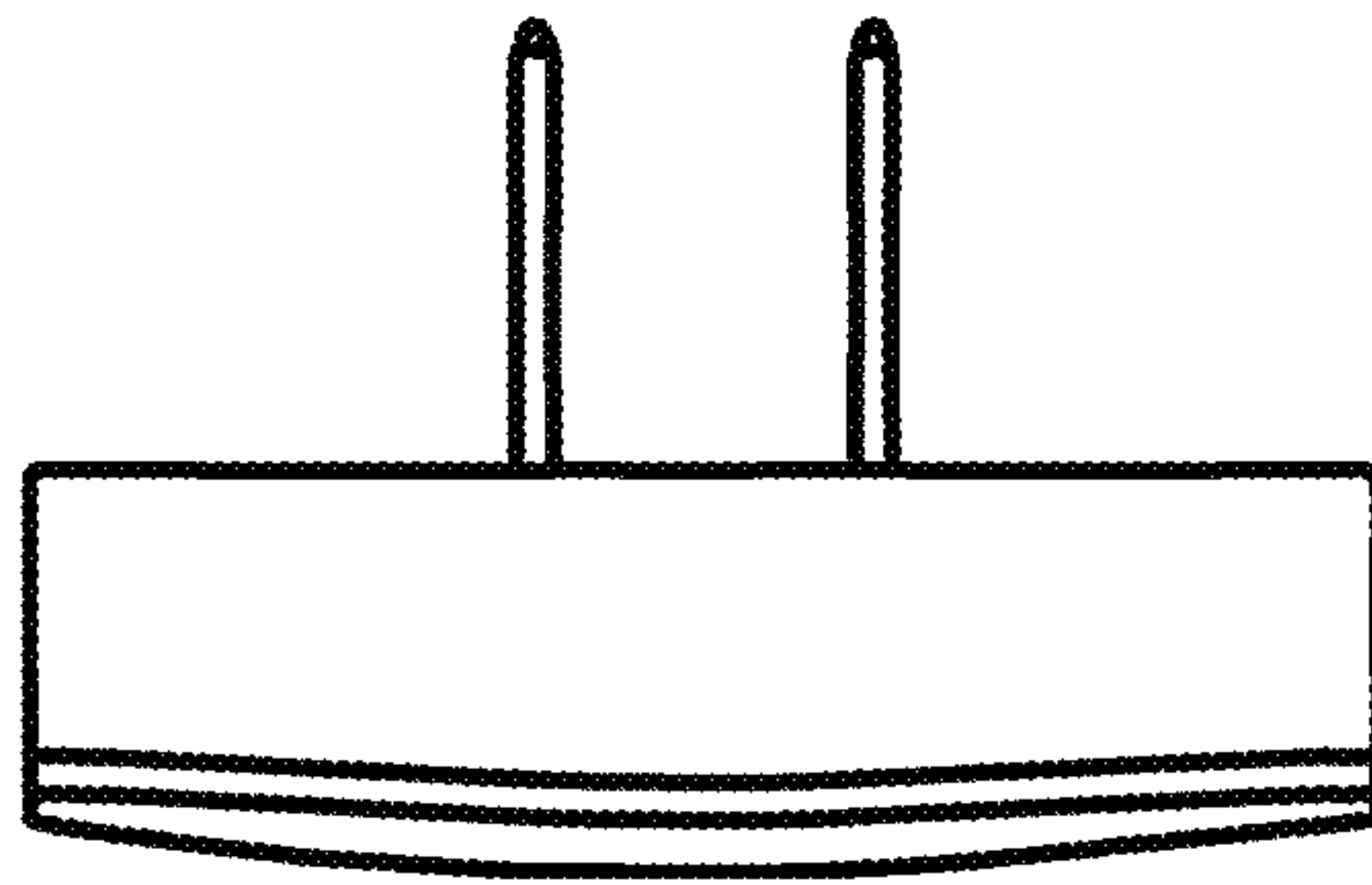

FIG.6

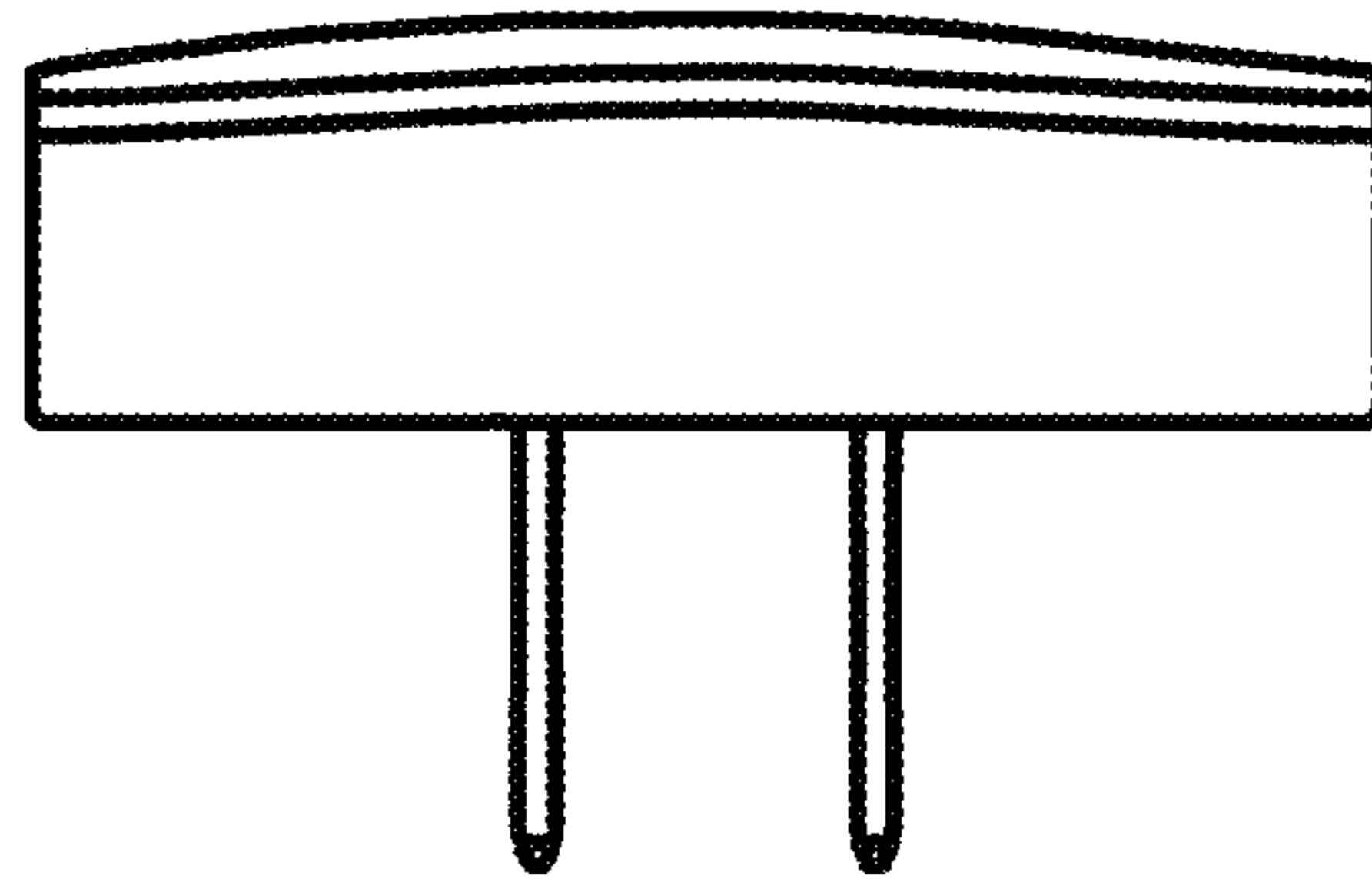

FIG.7