



US00D939675S

(12) **United States Design Patent** (10) **Patent No.:** **US D939,675 S**  
**Levi** (45) **Date of Patent:** **\*\* Dec. 28, 2021**

(54) **SINK**  
(71) Applicant: **KRAUS USA PLUMBING LLC**, Port Washington, NY (US)  
(72) Inventor: **Russell Levi**, Port Washington, NY (US)  
(73) Assignee: **KRAUS USA PLUMBING LLC**, Port Washington, NY (US)

D837,359 S \* 1/2019 Thimmareddy ..... D23/372  
D849,895 S 5/2019 Bucher  
D866,727 S \* 11/2019 Chen ..... D23/293.1  
D869,618 S \* 12/2019 Walther ..... D23/284  
D911,497 S \* 2/2021 Levi ..... D23/284  
2003/0204905 A1 11/2003 Ziemann et al.  
2006/0242761 A1 11/2006 Babick et al.  
2018/0030704 A1\* 2/2018 Bomatter ..... F16J 15/10  
2018/0030705 A1\* 2/2018 Bomatter ..... F16J 15/10  
2020/0399877 A1\* 12/2020 Liang ..... A47B 77/06

(\*\*) Term: **15 Years**  
(21) Appl. No.: **29/724,797**

\* cited by examiner  
*Primary Examiner* — Robert A Delehanty  
(74) *Attorney, Agent, or Firm* — Nirav D. Parikh; Edgar A. Zarins

(22) Filed: **Feb. 19, 2020**  
(51) **LOC (13) Cl.** ..... **23-02**  
(52) **U.S. Cl.**  
USPC ..... **D23/284**  
(58) **Field of Classification Search**  
USPC ..... D23/284, 286–287, 290, 292, 293.1, 308  
CPC ..... A47K 1/04; A47B 77/06  
See application file for complete search history.

(57) **CLAIM**  
The ornamental design for a sink, as shown and described.

(56) **References Cited**  
U.S. PATENT DOCUMENTS  
D478,970 S 8/2003 Ziemann et al.  
D538,409 S \* 3/2007 Gross ..... D23/293.1  
D648,838 S 11/2011 Booth  
D746,419 S 12/2015 Kurth et al.  
D769,423 S 10/2016 Lilly et al.

**DESCRIPTION**  
FIG. 1 is a front perspective view of a sink in accordance with the present design;  
FIG. 2 is a front elevational view thereof;  
FIG. 3 is a top plan view thereof;  
FIG. 4 is a bottom plan view thereof;  
FIG. 5 is a right side elevational thereof; and,  
FIG. 6 is a left side elevational view thereof.  
The broken lines shown are included for the purpose of illustrating a portion of the sink that form no part of the claimed design.

**1 Claim, 5 Drawing Sheets**

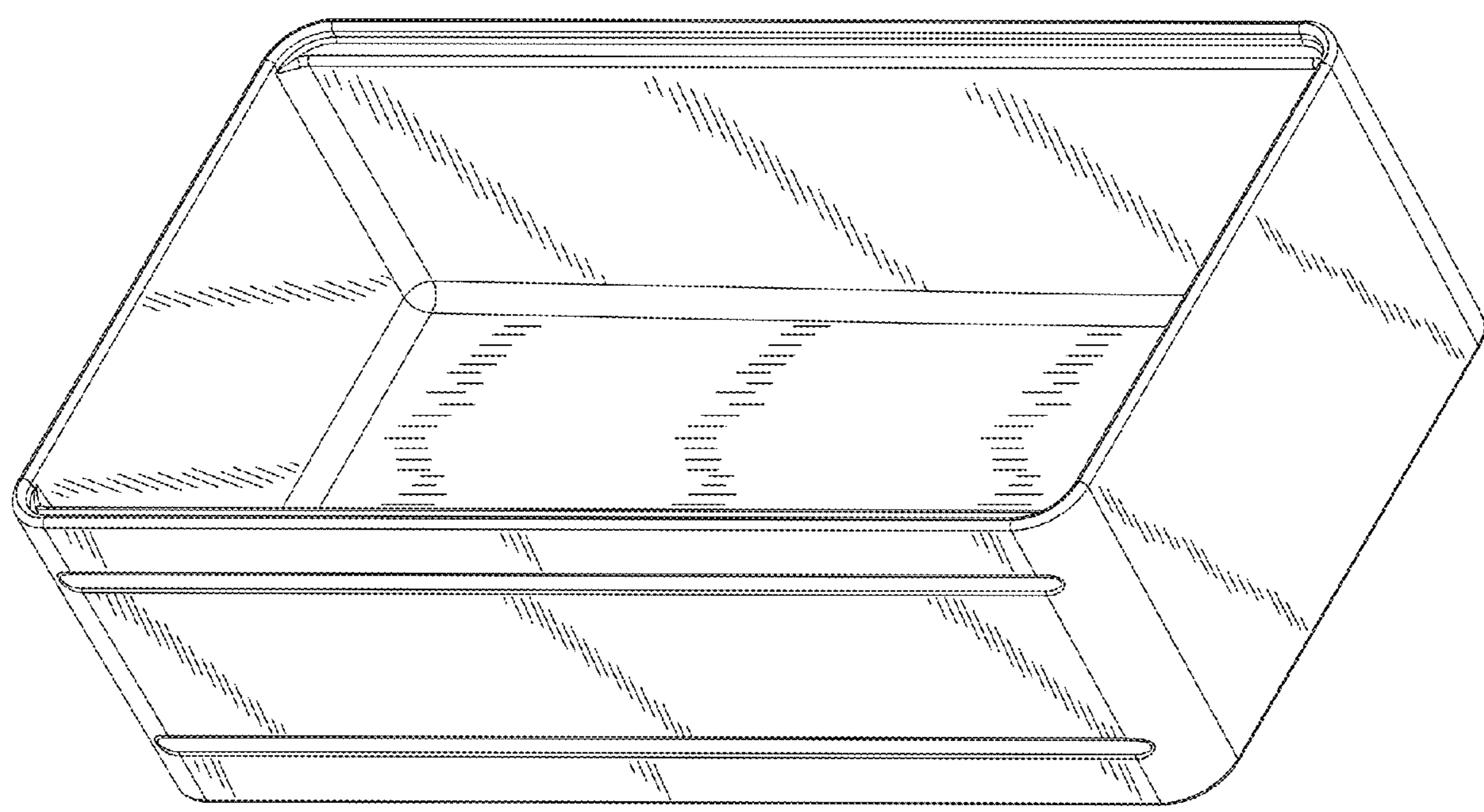

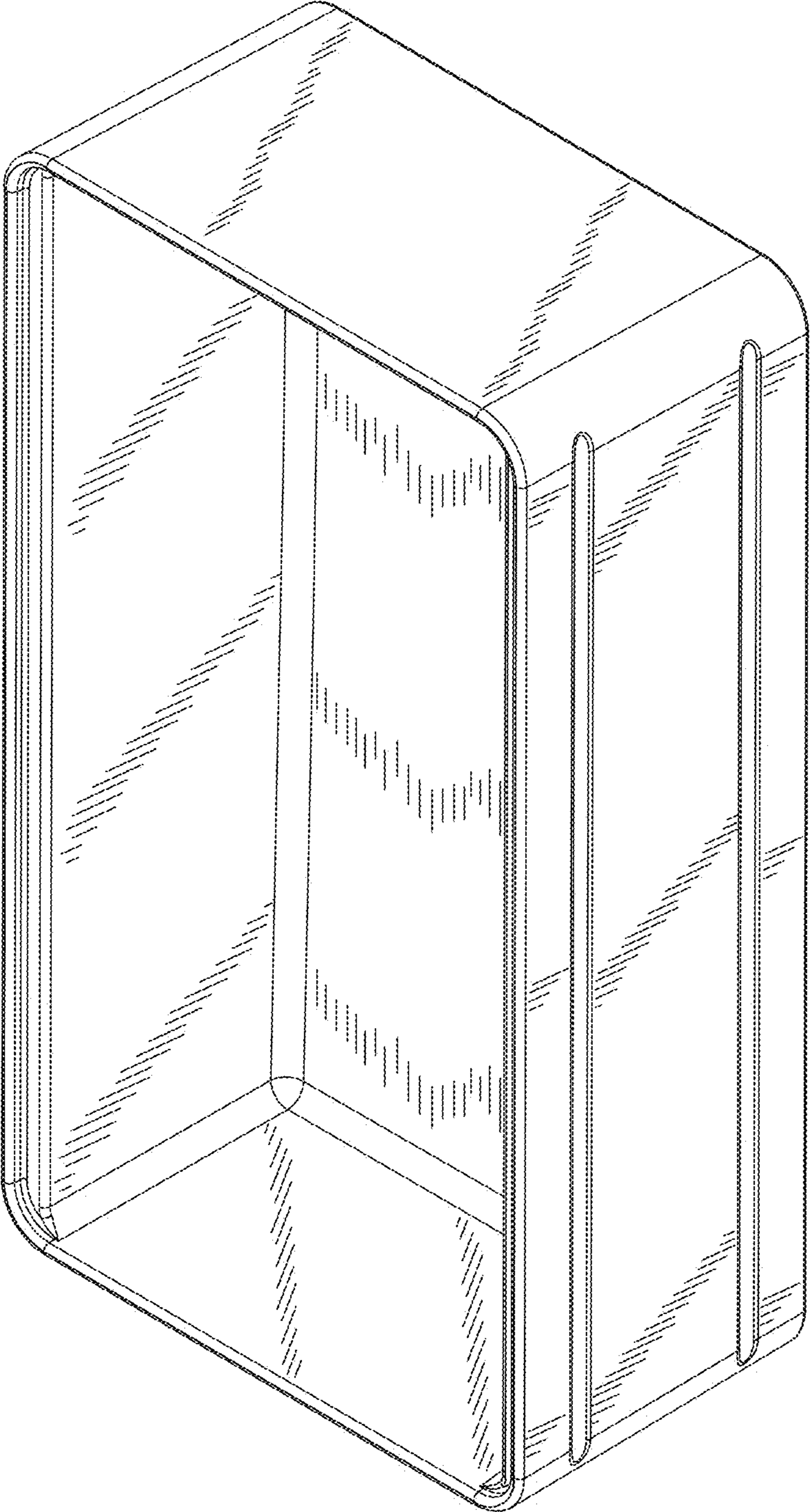

FIG. 1

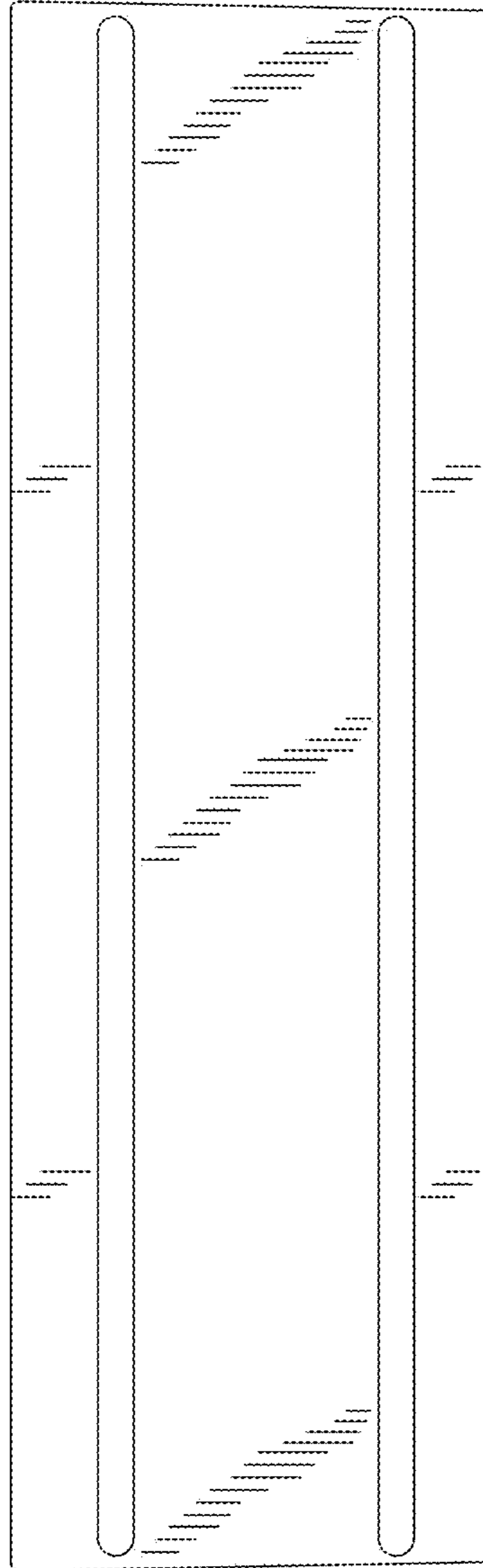

FIG. 2

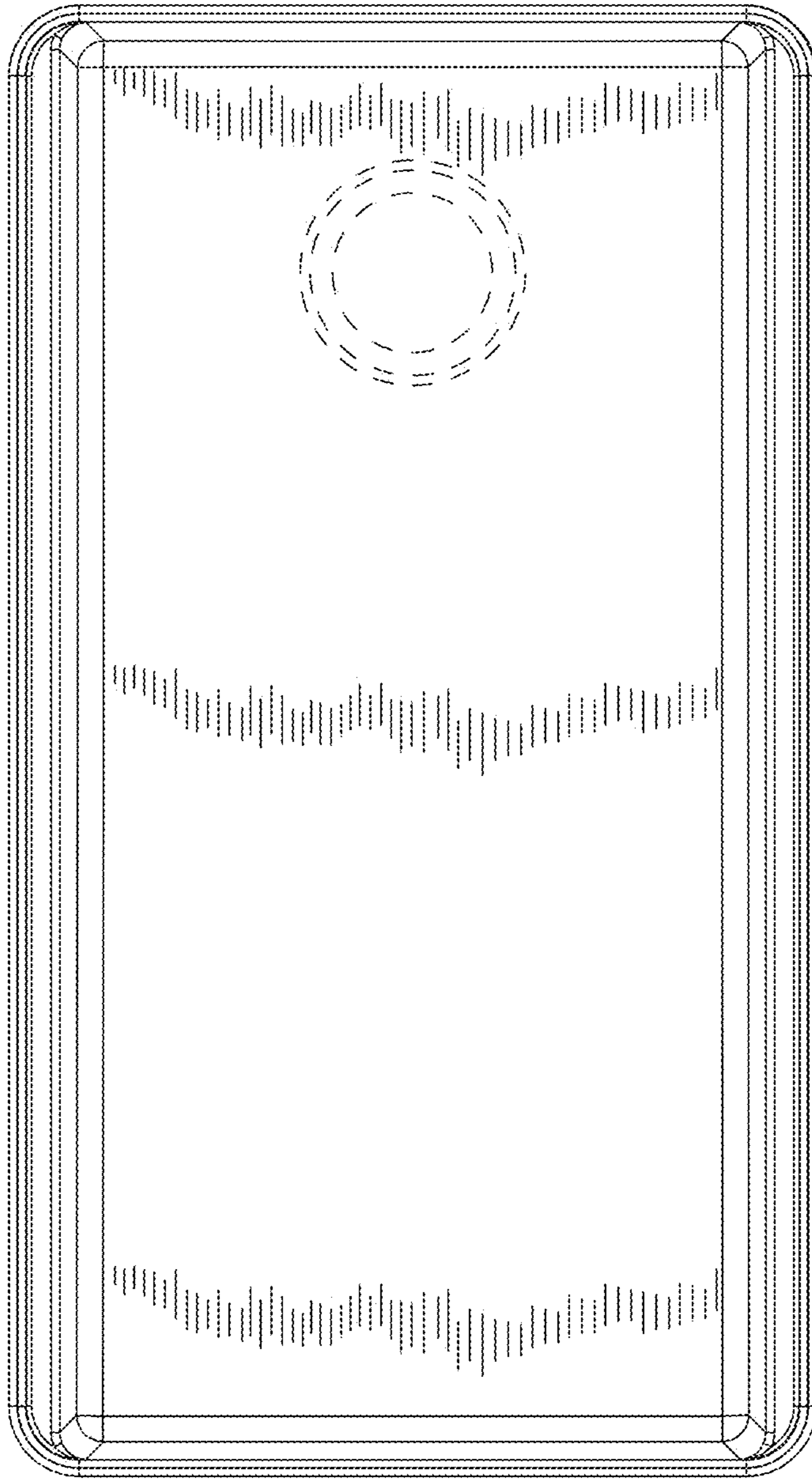

FIG. 3

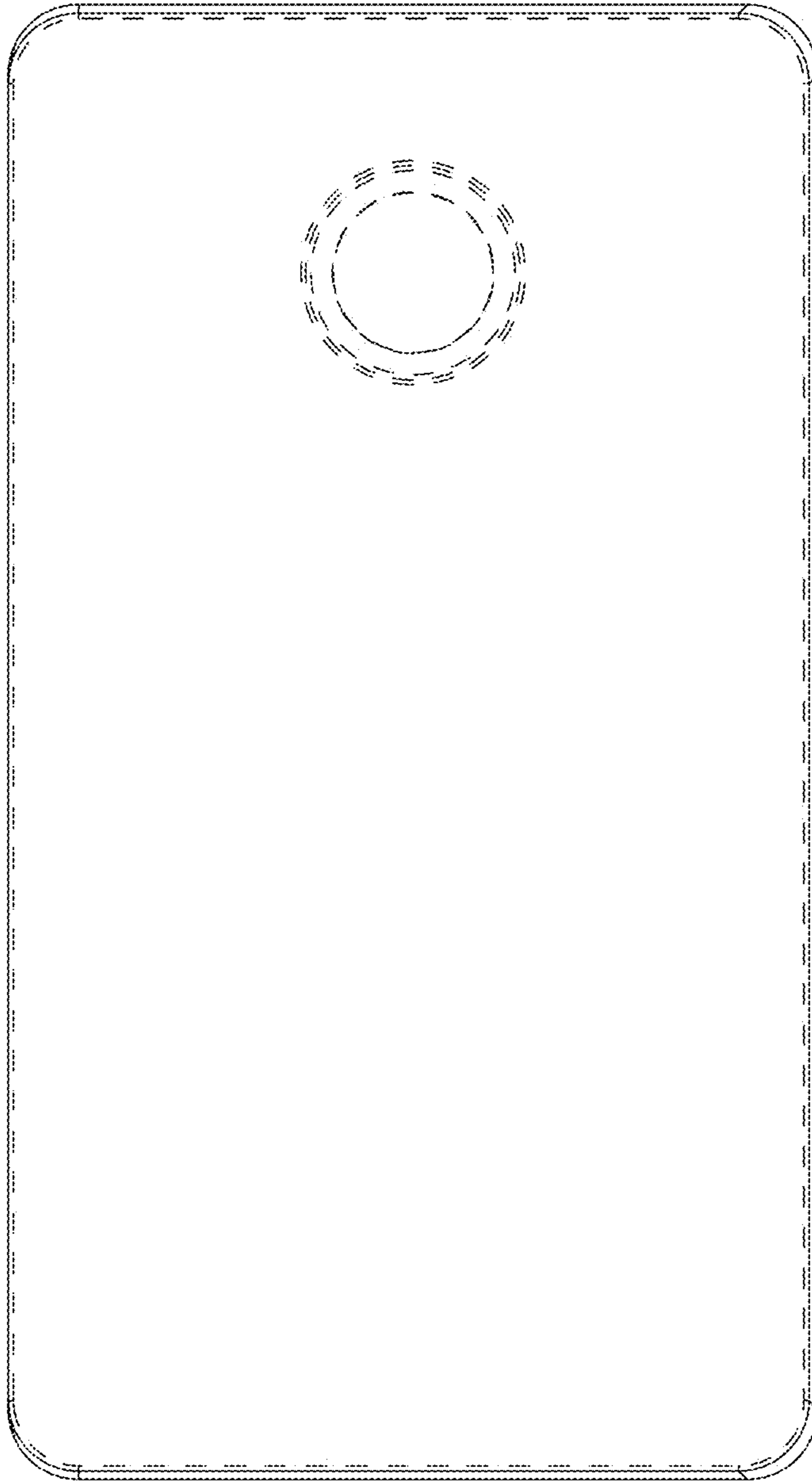

FIG. 4

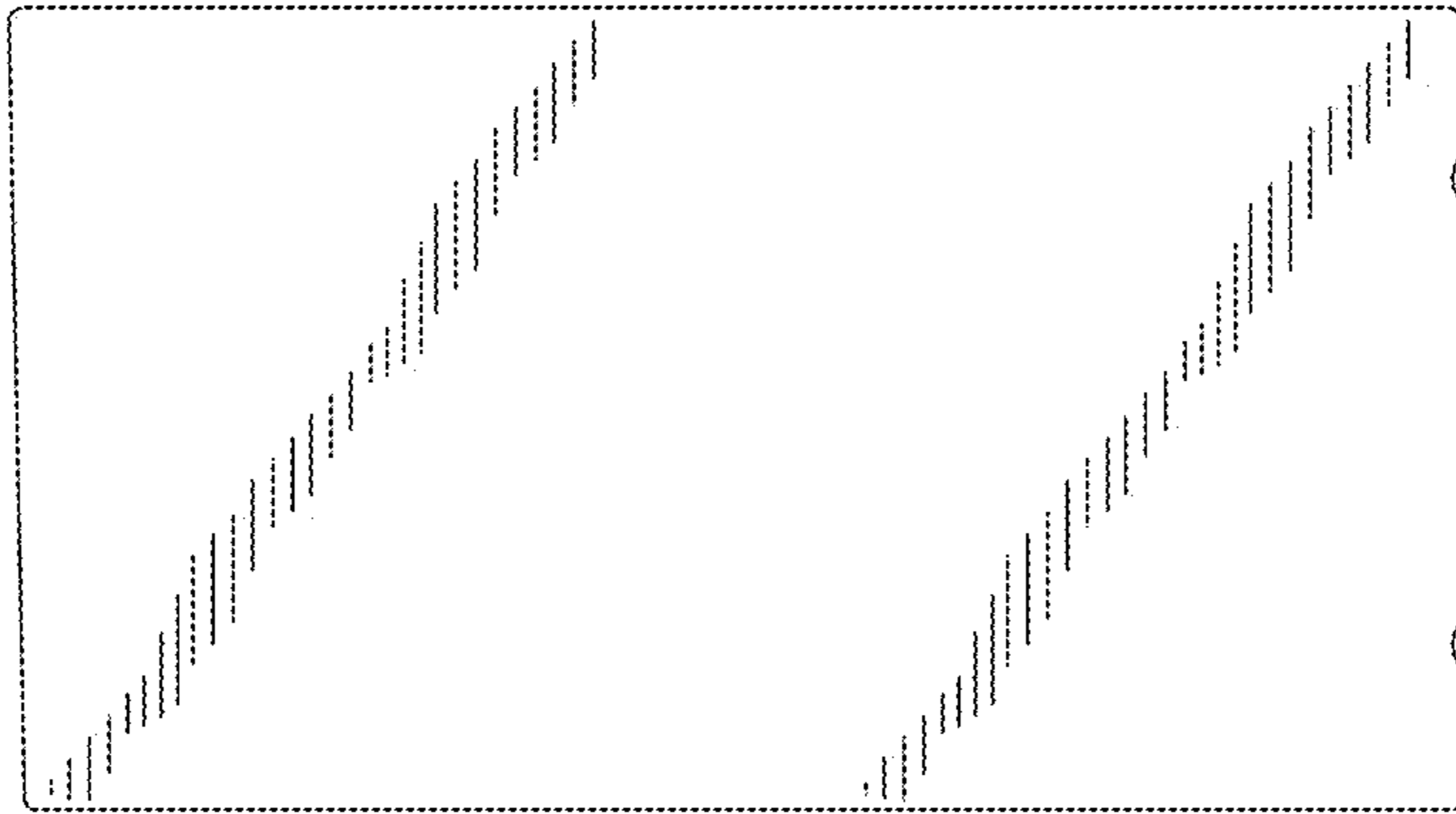

FIG. 6

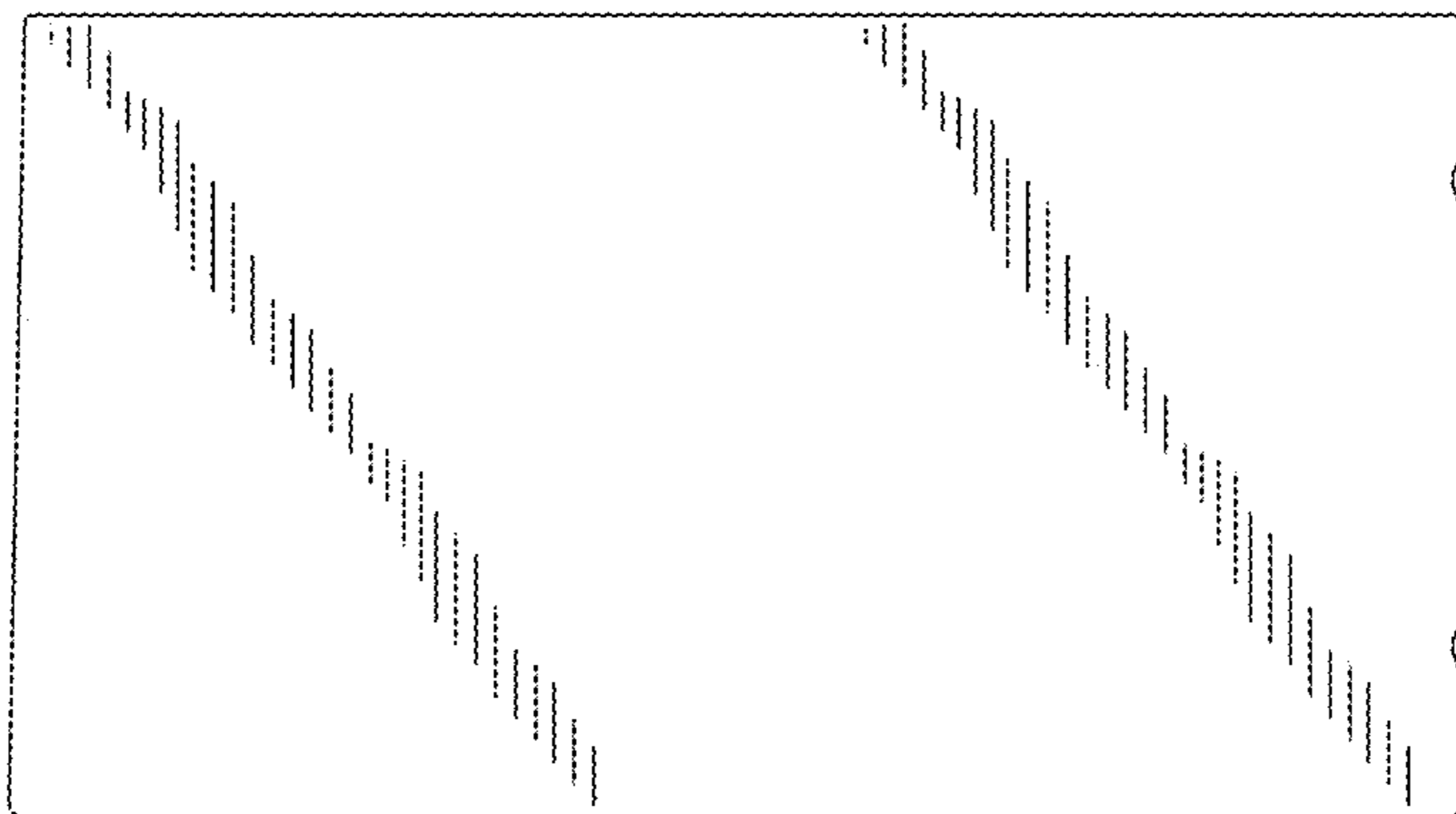

FIG. 5