



US00D939421S

(12) **United States Design Patent** (10) **Patent No.:** **US D939,421 S**  
**Li** (45) **Date of Patent:** **\*\* Dec. 28, 2021**

(54) **PEDAL DRIVE FOR KAYAK**  
(71) Applicant: **Zhengyun Li**, Chongqing (CN)  
(72) Inventor: **Zhengyun Li**, Chongqing (CN)  
(73) Assignee: **Cixi Luosaifei Kayak Co., Ltd.**,  
Zhejiang (CN)  
(\*\*) Term: **15 Years**  
(21) Appl. No.: **29/745,109**  
(22) Filed: **Aug. 4, 2020**  
(51) **LOC (13) Cl.** ..... **12-16**  
(52) **U.S. Cl.**  
USPC ..... **D12/214; D12/317**  
(58) **Field of Classification Search**  
USPC ..... D12/214, 317, 308, 344, 345, 300, 302,  
D12/303, 305, 306, 307, 309, 316, 112, 1,  
D12/2; D15/4; D21/542  
CPC ..... B63H 16/00; B63H 16/12; B63H 16/14;  
B63H 16/20; B63B 34/20; B63B 34/00  
See application file for complete search history.

(56) **References Cited**

U.S. PATENT DOCUMENTS

1,793,973 A \* 2/1931 Stamegna ..... B63H 16/14  
114/283  
D259,488 S \* 6/1981 Carter ..... D15/4  
4,813,367 A \* 3/1989 Stevenson ..... A63B 35/12  
114/315  
D505,104 S \* 5/2005 Osumi ..... D12/308  
D519,911 S \* 5/2006 Mah ..... D12/317  
D670,228 S \* 11/2012 Gilk ..... D12/214  
8,753,156 B2 \* 6/2014 Ketterman ..... B63H 25/42  
440/26  
D742,802 S \* 11/2015 Lukyanov ..... D12/306  
9,623,944 B2 \* 4/2017 Kuehmichel ..... B63B 34/20  
9,758,220 B1 \* 9/2017 Zimmerman ..... B63H 21/17  
D820,764 S \* 6/2018 Suzuki ..... D12/214

10,220,924 B1 \* 3/2019 Horvath ..... B63H 16/20  
D869,368 S \* 12/2019 Li ..... D12/214  
2003/0013355 A1 \* 1/2003 Free ..... B63H 16/14  
440/30  
2007/0178801 A1 \* 8/2007 Matias ..... A63H 23/10  
446/157  
2008/0188146 A1 \* 8/2008 Howard ..... B63H 16/20  
440/30  
2008/0200079 A1 \* 8/2008 Jansen ..... B63H 16/14  
440/1  
2008/0233813 A1 \* 9/2008 Ho ..... B63H 16/14  
440/29  
2009/0042461 A1 \* 2/2009 Walton ..... B63B 34/20  
440/6  
2010/0075550 A1 \* 3/2010 Bortsov ..... B63B 34/00  
440/26  
2016/0075420 A1 \* 3/2016 Kiffmeyer ..... B63H 16/20  
440/27  
2018/0009515 A1 \* 1/2018 Murphy ..... B63B 34/20  
2019/0263494 A1 \* 8/2019 Pelland ..... B63H 16/20

\* cited by examiner

*Primary Examiner* — Michelle E. Wilson  
*Assistant Examiner* — Clese Moore, Jr.

(57) **CLAIM**

The ornamental design for a pedal drive for kayak, as shown and described.

**DESCRIPTION**

FIG. 1 is a perspective view of a pedal drive for kayak showing my new design;  
FIG. 2 is a front elevation view thereof;  
FIG. 3 is a rear elevation view thereof;  
FIG. 4 is a left side elevation view thereof;  
FIG. 5 is a right side elevation view thereof;  
FIG. 6 is a top plan view thereof, shown enlarged in scale;  
and,  
FIG. 7 is a bottom plan view thereof, shown enlarged in scale.

**1 Claim, 7 Drawing Sheets**

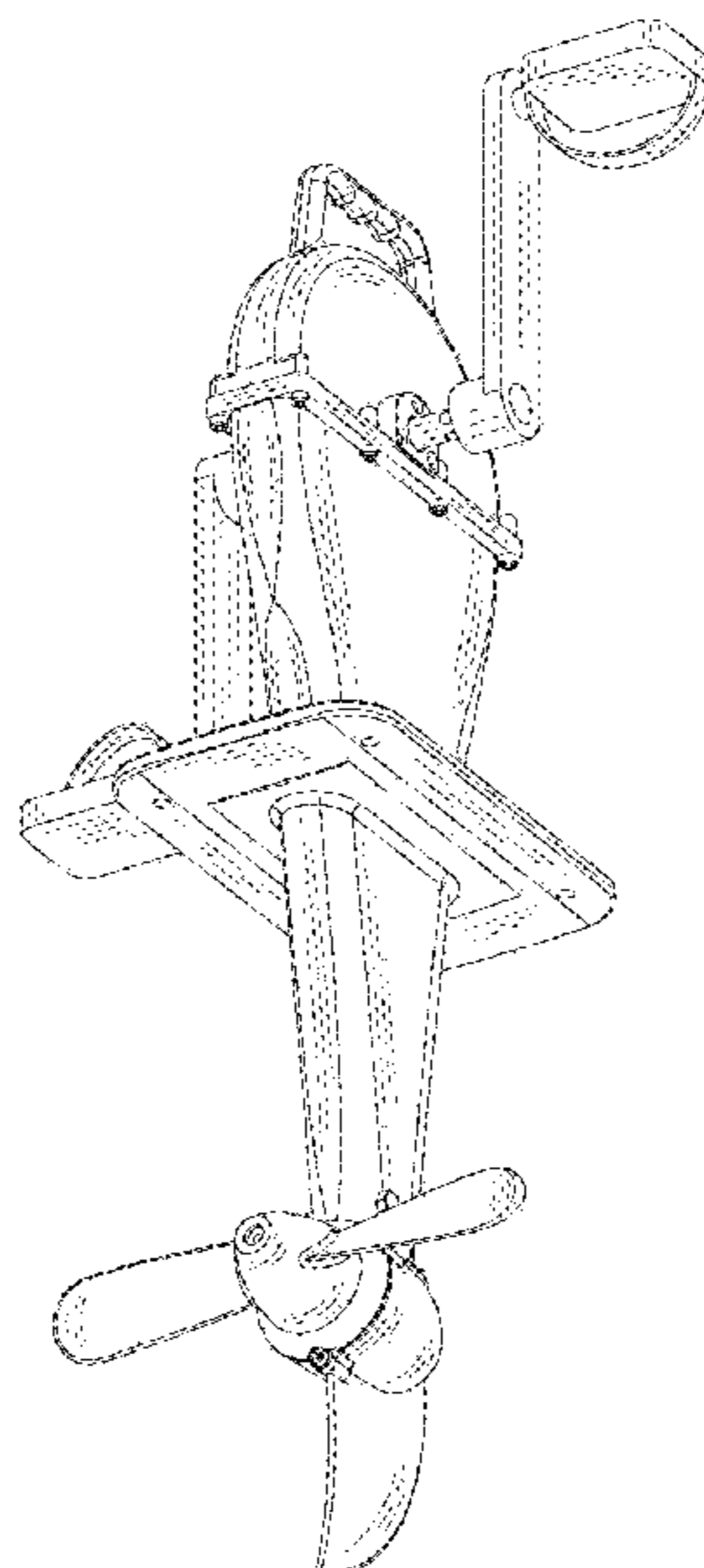

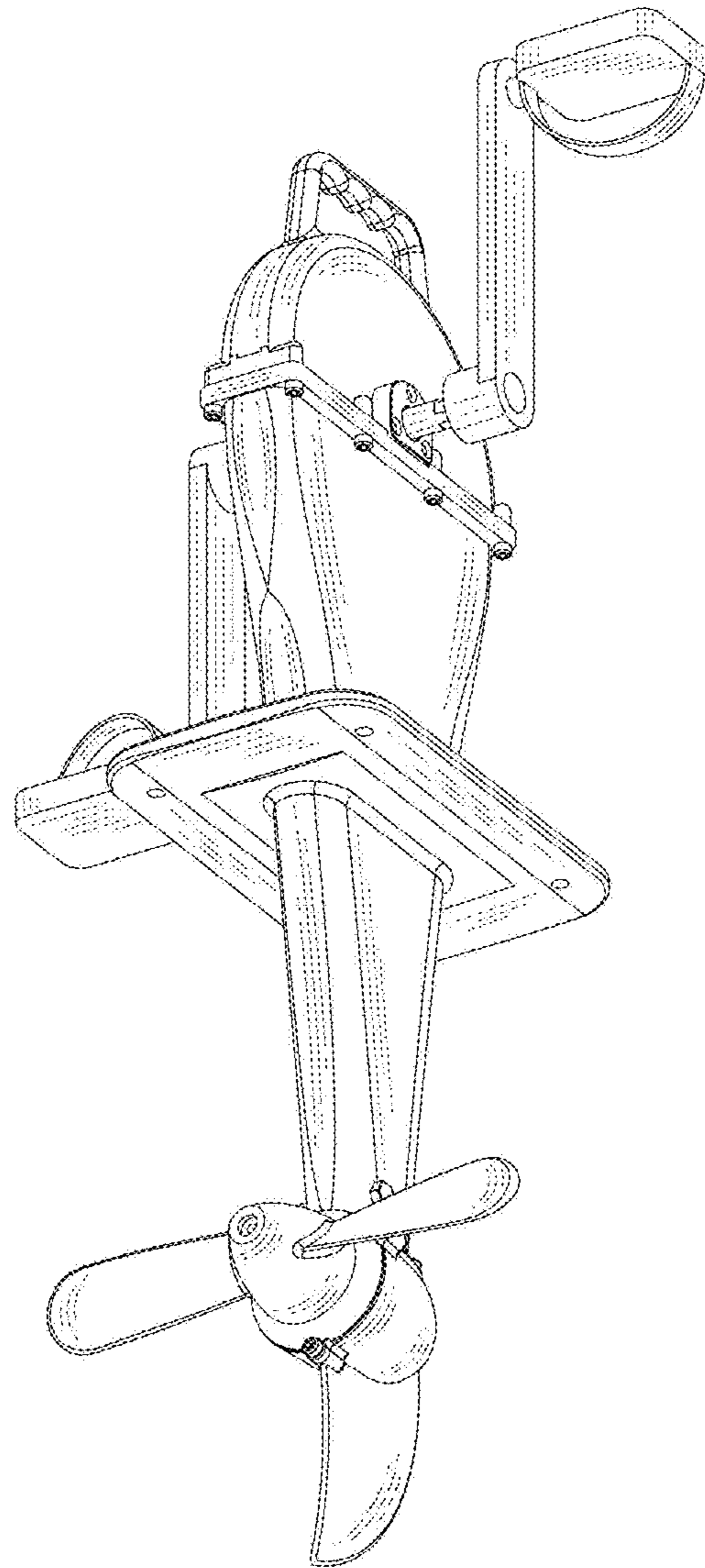

FIG.1

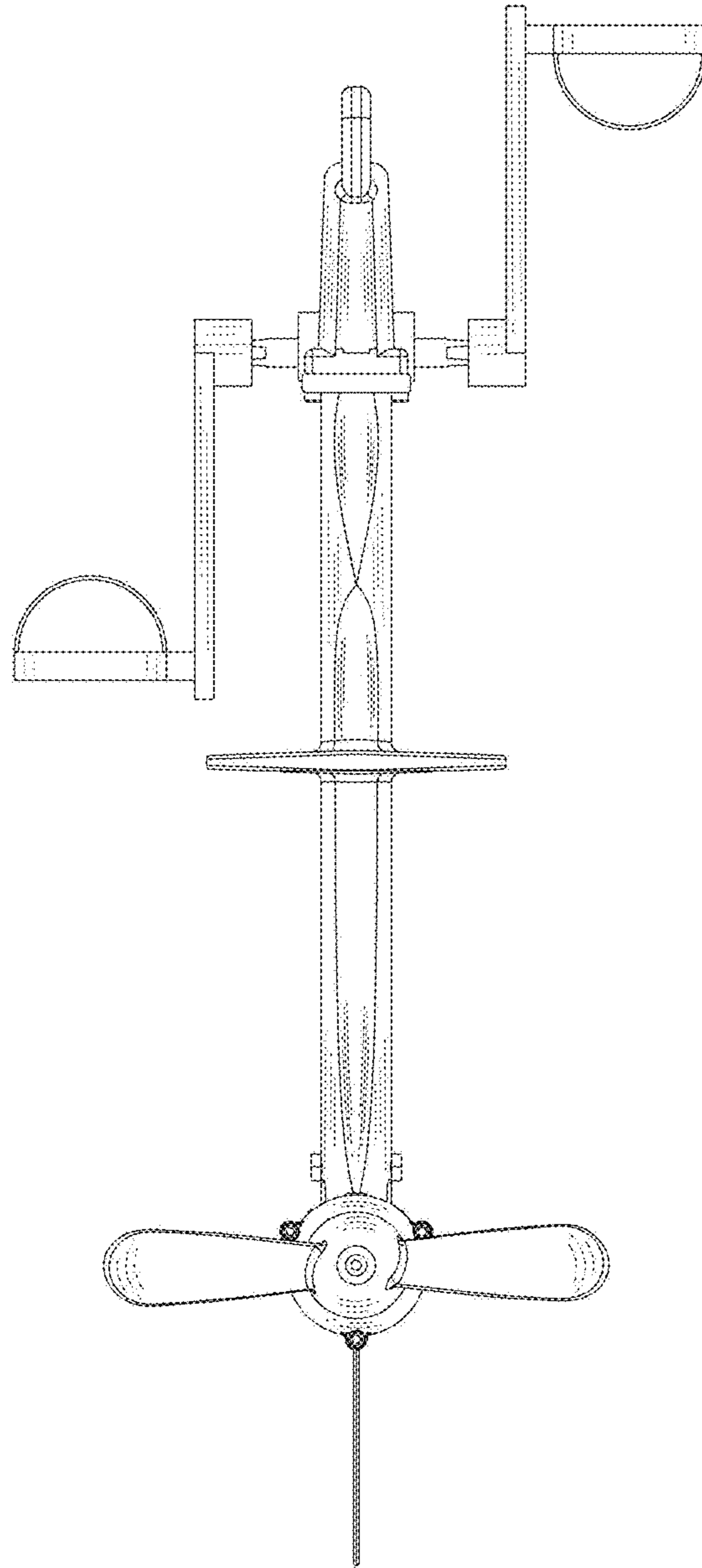

FIG.2

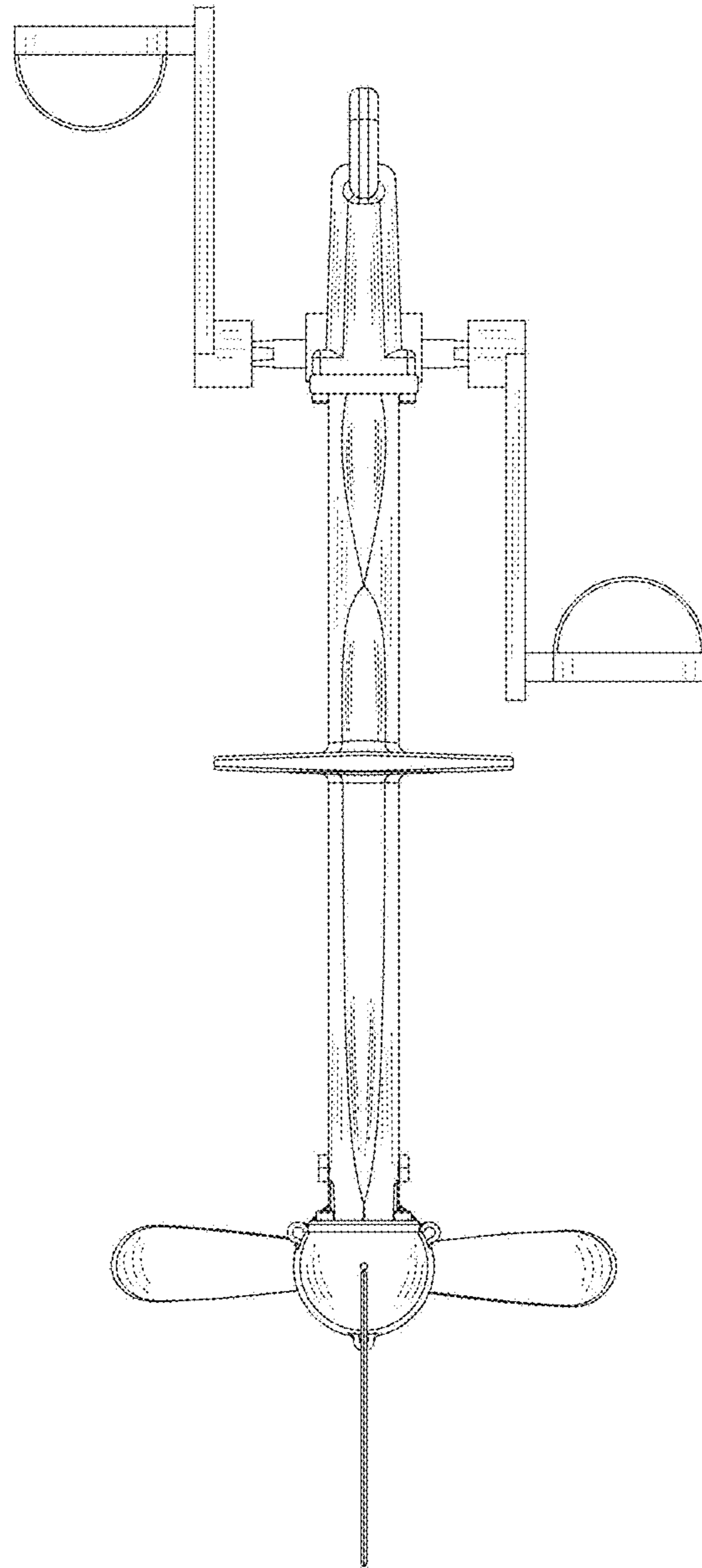

FIG.3

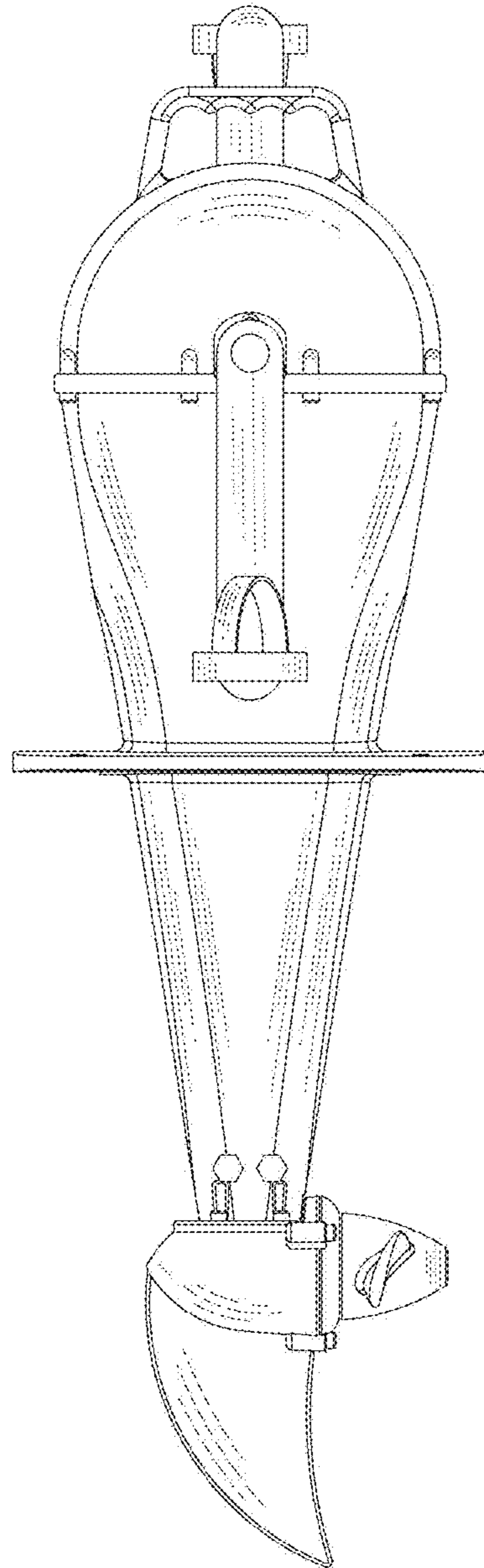

FIG.4

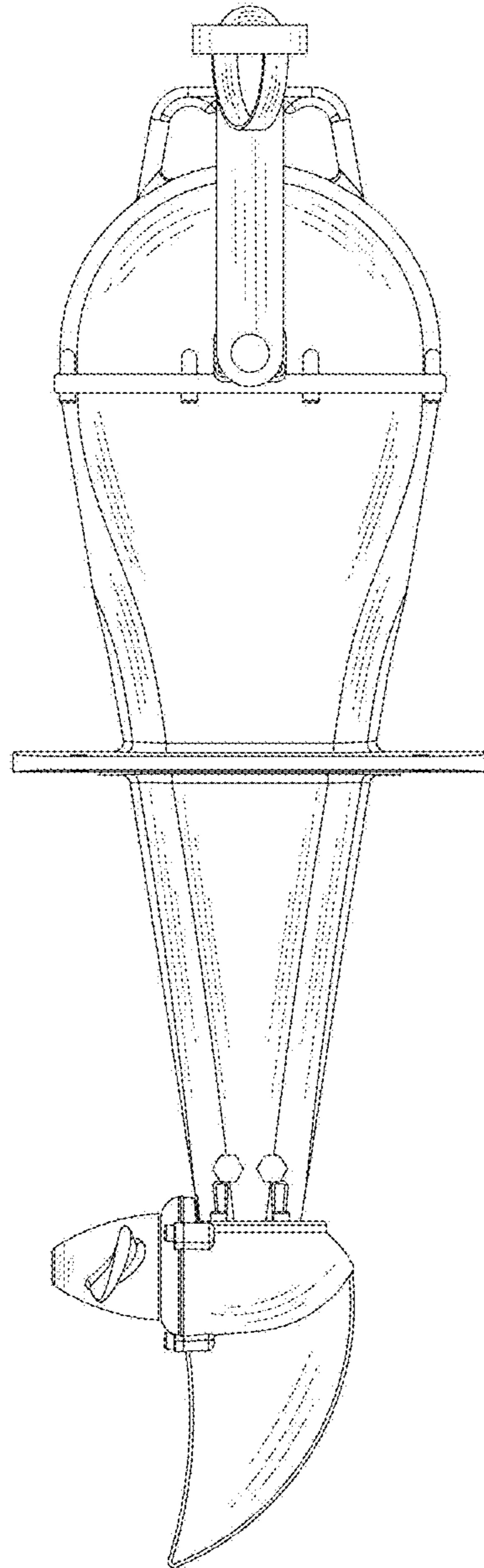

FIG.5

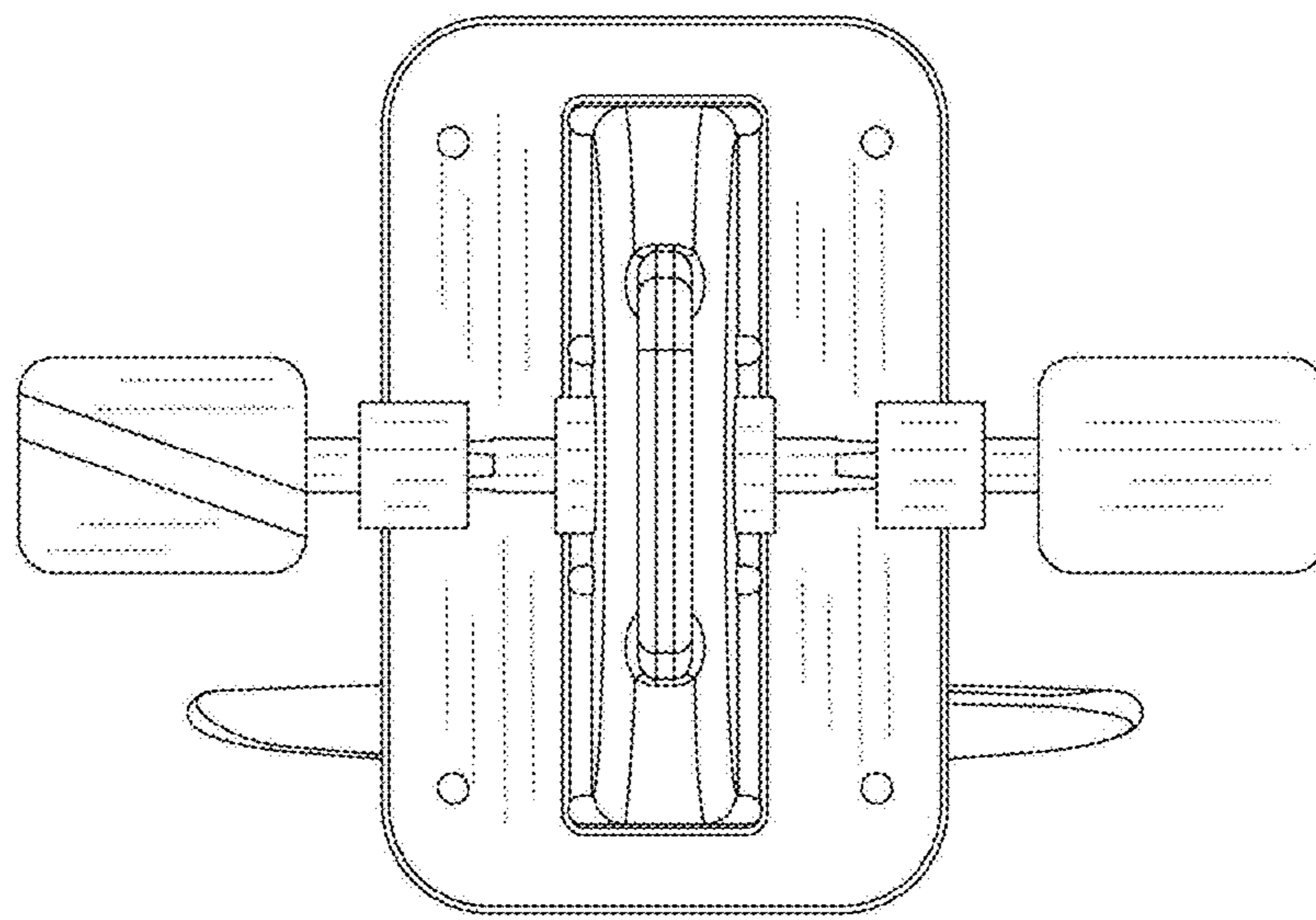

FIG.6

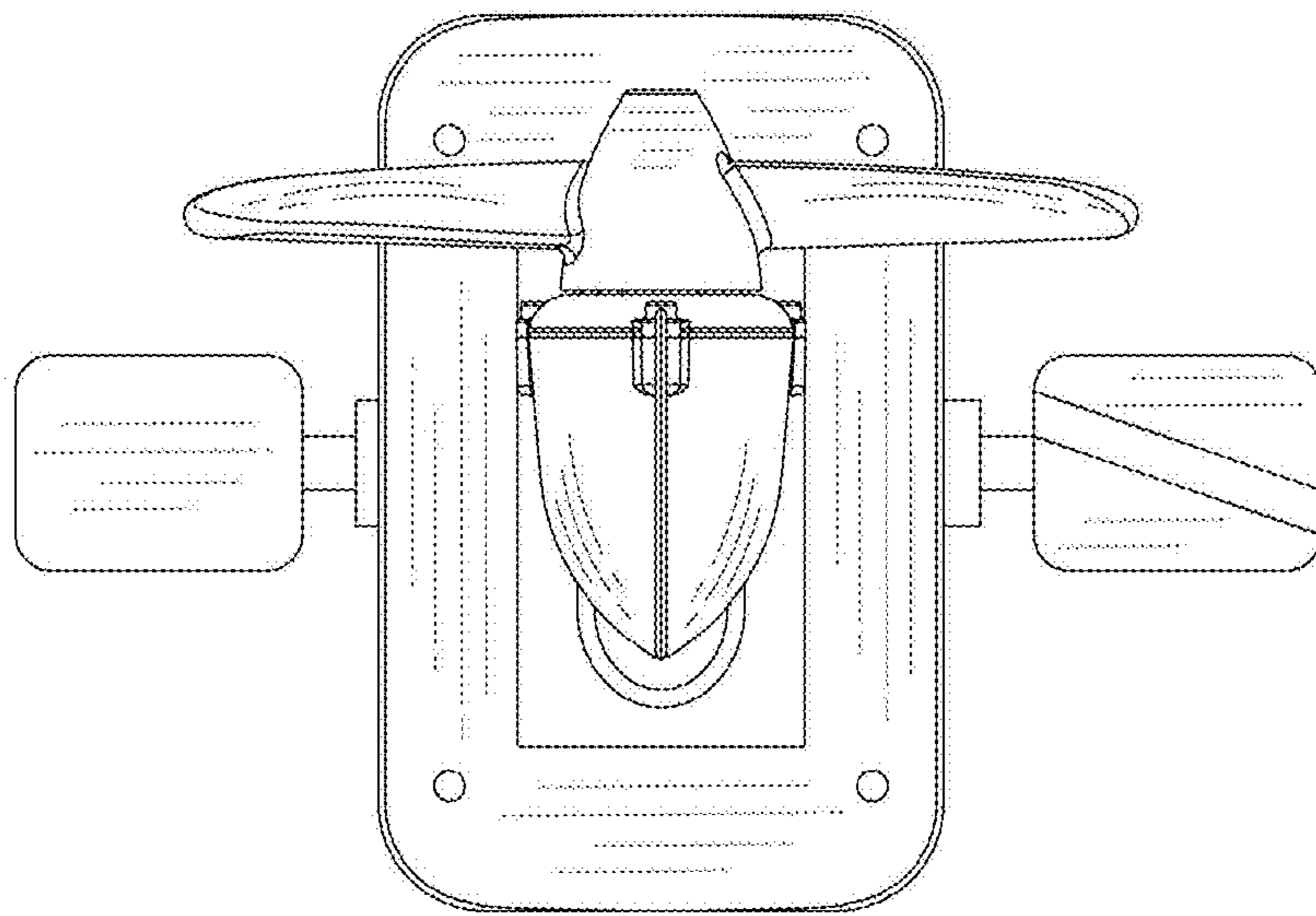

FIG. 7