



US00D939134S

(12) **United States Design Patent** (10) **Patent No.:** **US D939,134 S**
Danesh et al. (45) **Date of Patent:** **** Dec. 21, 2021**

(54) **MODULE APPLIED TO A LIGHTING ASSEMBLY**

(71) Applicant: **DMF, Inc.**, Carson, CA (US)
 (72) Inventors: **Michael D. Danesh**, Carson, CA (US);
Dan Hero De Guzman Cajumban,
 Hayward, CA (US)

(73) Assignee: **DMF, Inc.**, Carson, CA (US)

(**) Term: **15 Years**

(21) Appl. No.: **29/764,875**

(22) Filed: **Jan. 4, 2021**

Related U.S. Application Data

(63) Continuation of application No. 29/746,262, filed on Aug. 12, 2020, now Pat. No. Des. 907,284, which is a continuation of application No. 29/688,172, filed on Apr. 18, 2019, now Pat. No. Des. 924,467, which is a continuation of application No. 29/663,040, filed on Sep. 11, 2018, now Pat. No. Des. 847,415, which is a continuation of application No. 14/183,424, filed on Feb. 18, 2014, now Pat. No. 10,139,059.

(51) **LOC (13) Cl.** **26-05**

(52) **U.S. Cl.**
 USPC **D26/138**

(58) **Field of Classification Search**
 USPC D26/63, 72, 74, 76, 78-83, 85, 86, 88,
 D26/90, 93, 111, 113, 118, 119, 120, 121,
 D26/122, 138, 139, 140, 141, 142, 152
 CPC F21S 2/00; F21S 4/00; F21S 4/003; F21S
 4/005; F21S 4/006; F21S 4/007; F21S
 4/008; F21S 6/00; F21S 8/00; F21S
 8/024; F21S 8/026; F21S 8/031; F21S
 8/033; F21S 8/035-037; F21S 8/04; F21S
 8/043; F21S 8/063
 See application file for complete search history.

(56) **References Cited**

U.S. PATENT DOCUMENTS

1,133,535 A 3/1915 Cain et al.
 1,471,340 A 10/1923 Knight
 1,856,356 A 5/1932 Owen
 (Continued)

FOREIGN PATENT DOCUMENTS

CA 2243934 C 6/2002
 CA 2502637 A1 9/2005
 (Continued)

OTHER PUBLICATIONS

2006 International Building Code, Section 712 Penetrations, Jan. 2006, 4 pages.

(Continued)

Primary Examiner — Natasha Vujcic

(74) *Attorney, Agent, or Firm* — Smith Baluch LLP

(57) **CLAIM**

The ornamental design for a module applied to a lighting assembly, as shown and described.

DESCRIPTION

FIG. 1 is a front right perspective view of our design for a module applied to a lighting assembly; and, FIG. 2 is a front, plan view of our design for a module applied to a lighting assembly.

The portions or features of the module applied to a lighting assembly not shown in the drawings form no part of the claimed design. The dash-dash broken lines in the drawings are for the purpose of illustrating environmental subject matter and portions of the module applied to a lighting assembly that form no part of the claimed design. The dash-dot broken lines are for the purpose of illustrating a boundary and forms no part of the claimed design.

1 Claim, 2 Drawing Sheets

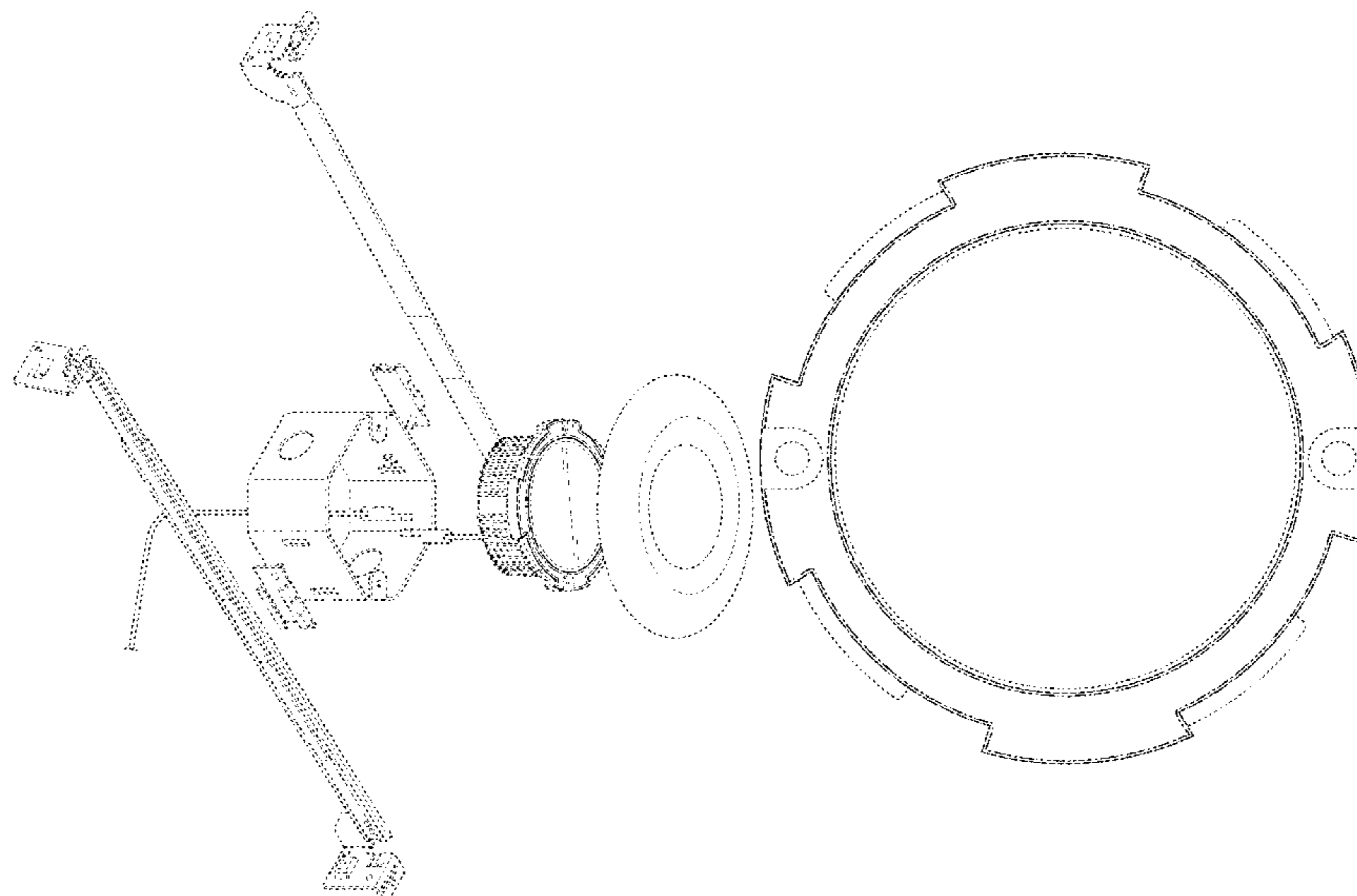

(56)

References Cited

U.S. PATENT DOCUMENTS

2,038,784 A	4/1936	Ghadiali	D386,277 S	11/1997	Lecluze
2,179,161 A	11/1939	Rambusch	5,690,423 A	11/1997	Hentz et al.
2,197,737 A	4/1940	Appleton	D387,466 S	12/1997	Lecluze
2,352,913 A	7/1944	Morrill	5,738,436 A	4/1998	Cummings et al.
2,528,989 A	11/1950	Ammells	5,778,625 A	7/1998	Druffel et al.
2,597,595 A	5/1952	Ordas	5,836,678 A	11/1998	Wright et al.
2,642,246 A	6/1953	Larry	5,942,726 A	8/1999	Reiker
2,670,919 A	3/1954	Vincent	5,944,412 A	8/1999	Janos et al.
2,697,535 A	12/1954	Olson	5,957,573 A	9/1999	Wedekind et al.
2,758,810 A	8/1956	Good	5,975,323 A	11/1999	Turan
D180,844 S	8/1957	Poliakoff	6,082,878 A	7/2000	Doubek et al.
2,802,933 A	8/1957	Harry	6,095,669 A	8/2000	Cho
2,998,512 A	8/1961	Duchene et al.	6,098,945 A	8/2000	Korcz
3,023,920 A	3/1962	Cook et al.	6,105,334 A	8/2000	Monson et al.
3,057,993 A	10/1962	Gellert	6,161,910 A	12/2000	Reisenauer et al.
3,104,087 A	9/1963	Joseph et al.	6,170,685 B1	1/2001	Currier
3,214,126 A	10/1965	Roos	6,174,076 B1	1/2001	Petrakis et al.
3,422,261 A	1/1969	McGinty	6,176,599 B1	1/2001	Farzen
3,460,299 A	8/1969	Wilson	6,267,491 B1	7/2001	Parrigin
3,650,046 A	3/1972	Skinner	6,332,597 B1	12/2001	Korcz et al.
3,675,807 A	7/1972	Lund et al.	6,350,043 B1	2/2002	Gloisten
3,700,885 A	10/1972	Bobrick	6,350,046 B1	2/2002	Lau
3,711,053 A	1/1973	Drake	6,364,511 B1	4/2002	Cohen
D227,989 S	7/1973	Geisel	6,375,338 B1	4/2002	Cummings et al.
3,773,968 A	11/1973	Copp	6,402,112 B1	6/2002	Thomas et al.
3,812,342 A	5/1974	Mcnamara	D461,455 S	8/2002	Forbes
3,836,766 A	9/1974	Auerbach	D465,061 S *	10/2002	Guthrie D23/269
3,874,035 A	4/1975	Schuplin	6,461,016 B1	10/2002	Jamison et al.
3,913,773 A	10/1975	Copp et al.	6,474,846 B1	11/2002	Kelmelis et al.
D245,905 S	9/1977	Taylor	6,491,413 B1	12/2002	Benesohn
4,088,827 A	5/1978	Kohaut	D468,697 S	1/2003	Straub, Jr.
4,154,218 A	5/1979	Hulet	D470,970 S	2/2003	Huang
4,154,219 A	5/1979	Gupta et al.	6,515,313 B1	2/2003	Ibbetson et al.
4,176,758 A	12/1979	Glick	6,521,833 B1	2/2003	DeFreitas
4,280,169 A	7/1981	Allen	D471,657 S	3/2003	Huang
4,399,497 A	8/1983	Druffel	6,583,573 B2	6/2003	Bierman
4,450,512 A	5/1984	Kristofek	6,585,389 B2	7/2003	Bonazzi
4,460,948 A	7/1984	Malola	6,600,175 B1	7/2003	Baretz et al.
4,520,435 A	5/1985	Baldwin	D478,872 S	8/2003	Heggem
4,539,629 A	9/1985	Poppenheimer	6,632,006 B1	10/2003	Rippel et al.
4,601,145 A	7/1986	Wilcox	6,657,236 B1	12/2003	Thibeault et al.
4,667,840 A	5/1987	Lindsey	6,666,419 B1	12/2003	Vrame
4,723,747 A	2/1988	Karp et al.	D488,583 S	4/2004	Benghozi
4,729,080 A	3/1988	Fremont et al.	6,719,438 B2	4/2004	Sevack et al.
4,754,377 A	6/1988	Wenman	6,758,578 B1	7/2004	Chou
4,770,311 A	9/1988	Wang	6,777,615 B1	8/2004	Gretz
4,880,128 A	11/1989	Jorgensen	6,779,908 B1	8/2004	Ng
4,910,651 A	3/1990	Montanez	6,827,229 B2	12/2004	Dinh et al.
4,919,292 A	4/1990	Hsu	6,838,618 B2	1/2005	Newbold et al.
4,929,187 A	5/1990	Hudson et al.	6,906,352 B2	6/2005	Edmond et al.
4,930,054 A	5/1990	Krebs	D509,314 S	9/2005	Rashidi
5,044,582 A	9/1991	Walters	6,948,829 B2	9/2005	Verdes et al.
D326,537 S	5/1992	Gattari	6,958,497 B2	10/2005	Emerson et al.
5,216,203 A	6/1993	Gower	6,964,501 B2	11/2005	Ryan
5,222,800 A	6/1993	Chan et al.	6,967,284 B1	11/2005	Gretz
5,239,132 A	8/1993	Bartow	D516,235 S	2/2006	Rashidi
5,250,269 A	10/1993	Langer et al.	7,025,476 B2	4/2006	Leadford
5,266,050 A	11/1993	O'Neil et al.	7,025,477 B2	4/2006	Blessing
5,303,894 A	4/1994	Deschamps et al.	7,064,269 B2	6/2006	Smith
5,382,752 A	1/1995	Reyhan et al.	D528,673 S	9/2006	Maxik et al.
5,420,376 A	5/1995	Rajecki et al.	7,102,172 B2	9/2006	Lynch
5,444,606 A	8/1995	Barnes et al.	D531,740 S	11/2006	Maxik
5,465,199 A	11/1995	Bray et al.	D532,532 S	11/2006	Maxik
5,505,419 A	4/1996	Gabrius	7,148,420 B1	12/2006	Johnson et al.
5,544,870 A	8/1996	Kelly et al.	7,148,632 B2	12/2006	Berman et al.
5,562,343 A	10/1996	Chan et al.	7,152,985 B2	12/2006	Benitez et al.
5,571,993 A	11/1996	Jones et al.	7,154,040 B1	12/2006	Tompkins
5,580,158 A	12/1996	Aubrey et al.	7,170,015 B1	1/2007	Roesch et al.
5,588,737 A	12/1996	Kusmer	D536,349 S	2/2007	Humber et al.
D377,843 S *	2/1997	Schering D26/138	D537,039 S	2/2007	Pincek
5,603,424 A	2/1997	Bordwell et al.	7,181,378 B2	2/2007	Benitez et al.
5,609,408 A	3/1997	Targetti	D539,229 S	3/2007	Murphey
5,613,338 A	3/1997	Esposito	7,186,008 B2	3/2007	Patti
D381,111 S	7/1997	Lecluze	7,190,126 B1	3/2007	Paton
5,662,413 A	9/1997	Akiyama et al.	7,211,833 B2	5/2007	Slater, Jr. et al.
			7,213,940 B1	5/2007	Van De Ven et al.
			7,234,674 B2	6/2007	Rippel et al.
			D547,889 S	7/2007	Huang
			D552,969 S	10/2007	Bobrowski et al.

(56)

References Cited

U.S. PATENT DOCUMENTS

D553,267 S	10/2007	Yuen	D633,224 S	2/2011	Lee
D555,106 S	11/2007	Pape et al.	7,909,487 B1	3/2011	Venetucci et al.
D556,144 S	11/2007	Dinh	D636,117 S *	4/2011	Kim D26/138
7,297,870 B1	11/2007	Sartini	D636,118 S *	4/2011	Kim D26/138
7,312,474 B2	12/2007	Emerson et al.	D636,903 S	4/2011	Torenbeek
7,320,536 B2	1/2008	Petrakis et al.	D637,339 S	5/2011	Hasan et al.
D561,372 S	2/2008	Yan	D637,340 S	5/2011	Hasan et al.
D561,373 S	2/2008	Yan	7,950,832 B2	5/2011	Tanaka et al.
7,335,920 B2	2/2008	Denbaars et al.	D639,499 S	6/2011	Choi et al.
D563,896 S	3/2008	Greenslate	D640,819 S	6/2011	Pan
7,347,580 B2	3/2008	Blackman et al.	7,956,546 B2	6/2011	Hasnain
D570,012 S	5/2008	Huang	7,959,332 B2	6/2011	Tickner et al.
7,374,308 B2	5/2008	Sevack et al.	7,967,480 B2	6/2011	Pickard et al.
D570,504 S	6/2008	Maxik et al.	D642,317 S	7/2011	Rashidi
D570,505 S	6/2008	Maxik et al.	7,972,035 B2	7/2011	Boyer
7,399,104 B2	7/2008	Rappaport	7,972,043 B2	7/2011	Schutte
7,429,025 B1	9/2008	Gretz	D642,536 S	8/2011	Robinson
D578,677 S	10/2008	Huang	D643,970 S	8/2011	Kim et al.
7,431,482 B1	10/2008	Morgan et al.	8,002,425 B2	8/2011	Russo et al.
7,432,440 B2	10/2008	Hull et al.	D646,011 S	9/2011	Rashidi
7,442,883 B2	10/2008	Jolly et al.	8,013,243 B2	9/2011	Korcz et al.
7,446,345 B2	11/2008	Emerson et al.	8,038,113 B2	10/2011	Fryzek et al.
7,470,048 B2	12/2008	Wu	D648,476 S	11/2011	Choi et al.
7,473,005 B2	1/2009	O'Brien	D648,477 S	11/2011	Kim et al.
D586,497 S	2/2009	Wu et al.	D650,115 S	12/2011	Kim et al.
7,488,097 B2	2/2009	Reisenauer et al.	8,070,328 B1	12/2011	Knoble et al.
7,494,258 B2	2/2009	McNaught	8,096,670 B2	1/2012	Trott
7,503,145 B2	3/2009	Newbold et al.	D654,205 S	2/2012	Rashidi
7,524,089 B2	4/2009	Park	D656,262 S	3/2012	Yoshinobu et al.
D591,894 S	5/2009	Flank	D656,263 S	3/2012	Ogawa et al.
7,534,989 B2	5/2009	Suehara et al.	8,142,057 B2	3/2012	Roos et al.
D596,154 S	7/2009	Rivkin	8,152,334 B2	4/2012	Krogman
7,566,154 B2	7/2009	Gloisten et al.	D658,788 S	5/2012	Dudik et al.
D599,040 S	8/2009	Alexander et al.	D658,802 S	5/2012	Chen
D600,836 S	9/2009	Hanley et al.	D659,862 S	5/2012	Tsai
7,588,359 B2	9/2009	Coushaine et al.	D659,879 S	5/2012	Rashidi
7,592,583 B2	9/2009	Page et al.	D660,814 S	5/2012	Wilson
D606,696 S	12/2009	Chen et al.	8,182,116 B2	5/2012	Zhang et al.
7,625,105 B1	12/2009	Johnson	8,201,968 B2	6/2012	Maxik et al.
7,628,513 B2	12/2009	Chiu	D663,058 S	7/2012	Pan
7,651,238 B2	1/2010	O'Brien	D663,466 S	7/2012	Rashidi
7,654,705 B2	2/2010	Czech et al.	D664,274 S	7/2012	de Visser et al.
D611,650 S	3/2010	Broekhoff	D664,705 S	7/2012	Kong et al.
7,670,021 B2	3/2010	Chou	8,215,805 B2	7/2012	Cogliano et al.
7,673,841 B2	3/2010	Wronski	8,220,970 B1	7/2012	Khazi et al.
7,677,766 B2	3/2010	Boyer	8,226,270 B2	7/2012	Yamamoto et al.
7,692,182 B2	4/2010	Bergmann et al.	8,235,549 B2	8/2012	Gingrich, III et al.
7,704,763 B2	4/2010	Fujii et al.	8,238,050 B2	8/2012	Minano et al.
D616,118 S	5/2010	Thomas et al.	8,240,630 B2	8/2012	Wronski
7,712,922 B2	5/2010	Hacker et al.	D667,155 S	9/2012	Rashidi
7,722,208 B1	5/2010	Dupre et al.	8,262,255 B1	9/2012	Rashidi
7,722,227 B2	5/2010	Zhang et al.	D668,372 S	10/2012	Renshaw et al.
7,735,795 B2	6/2010	Wronski	D668,809 S	10/2012	Rashidi
7,735,798 B2	6/2010	Kojima	D669,198 S	10/2012	Qiu
7,748,887 B2	7/2010	Zampini, II et al.	D669,199 S	10/2012	Chuang
7,766,518 B2	8/2010	Piepgras et al.	D669,620 S	10/2012	Rashidi
7,769,192 B2	8/2010	Takagi et al.	8,277,090 B2	10/2012	Fryzek et al.
7,771,082 B2	8/2010	Peng	D671,668 S	11/2012	Rowlette, Jr. et al.
7,771,094 B2	8/2010	Goode	8,308,322 B2	11/2012	Santiago et al.
7,784,754 B2	8/2010	Nevers et al.	D672,899 S	12/2012	Ven et al.
D624,691 S	9/2010	Zhang et al.	D673,869 S	1/2013	Yu
D624,692 S	9/2010	Mackin et al.	D676,263 S	2/2013	Birke
D625,847 S	10/2010	Maglica	D676,814 S	2/2013	Paul
D625,876 S	10/2010	Chen et al.	8,376,593 B2	2/2013	Bazydola et al.
D627,507 S	11/2010	Lai et al.	D677,417 S	3/2013	Rashidi
D627,727 S	11/2010	Alexander et al.	D677,634 S	3/2013	Korcz et al.
7,828,465 B2	11/2010	Roberge et al.	D679,044 S	3/2013	Jeswani et al.
D629,366 S	12/2010	Ericson et al.	D679,047 S	3/2013	Tickner et al.
7,845,393 B2	12/2010	Kao et al.	8,403,533 B1	3/2013	Paulsel
7,857,275 B2	12/2010	de la Borbolla	8,403,541 B1	3/2013	Rashidi
7,871,184 B2	1/2011	Peng	8,405,947 B1	3/2013	Green et al.
7,874,539 B2	1/2011	Wright et al.	D681,259 S	4/2013	Kong
7,874,703 B2	1/2011	Shastry et al.	8,408,759 B1	4/2013	Rashidi
7,874,709 B1	1/2011	Beadle	D682,459 S	5/2013	Gordin et al.
D632,839 S *	2/2011	Kim D26/138	D683,063 S	5/2013	Lopez et al.
			D683,890 S	6/2013	Lopez et al.
			D684,269 S	6/2013	Wang et al.
			D684,287 S	6/2013	Rashidi
			D684,719 S	6/2013	Rashidi

(56)

References Cited

U.S. PATENT DOCUMENTS

D685,118 S	6/2013	Rashidi	D726,949 S	4/2015	Redfern
D685,120 S	6/2013	Rashidi	D728,129 S *	4/2015	Kreuzbichler D26/1
8,454,204 B1	6/2013	Chang et al.	9,004,435 B2	4/2015	Wronski
D685,507 S	7/2013	Sun	9,039,254 B2	5/2015	Danesh
D687,586 S	8/2013	Rashidi	D731,689 S	6/2015	Bernard et al.
D687,587 S	8/2013	Rashidi	9,062,866 B1	6/2015	Christ et al.
D687,588 S	8/2013	Rashidi	9,065,264 B2	6/2015	Cooper et al.
D687,980 S	8/2013	Gravely et al.	9,068,719 B2	6/2015	Van De Ven et al.
D688,405 S	8/2013	Kim et al.	9,068,722 B2	6/2015	Wronski et al.
8,506,127 B2	8/2013	Russello et al.	D734,525 S	7/2015	Gordin et al.
8,506,134 B2	8/2013	Wilson et al.	D735,012 S	7/2015	Cowie
D690,049 S	9/2013	Rashidi	D735,142 S	7/2015	Hagarty
D690,053 S	9/2013	Zhang et al.	9,078,299 B2	7/2015	Ashdown
D690,864 S	10/2013	Rashidi	D735,933 S	8/2015	Campagna
D690,865 S	10/2013	Rashidi	9,109,760 B2	8/2015	Shum et al.
D690,866 S	10/2013	Rashidi	9,109,783 B1	8/2015	Davis et al.
D691,314 S	10/2013	Rashidi	D739,355 S	9/2015	D'Aubeterre
D691,315 S	10/2013	Samson	D739,590 S	9/2015	Redfern
D691,763 S	10/2013	Hand et al.	9,140,441 B2	9/2015	Goelz et al.
8,550,669 B2	10/2013	Macwan et al.	D741,538 S	10/2015	Ghasabi
D693,043 S	11/2013	Schmalfuss et al.	9,151,457 B2	10/2015	Pickard et al.
D693,517 S	11/2013	Davis	9,151,477 B2	10/2015	Pickard et al.
D694,456 S	11/2013	Rowlette, Jr. et al.	D742,325 S	11/2015	Leung
8,573,816 B2	11/2013	Negley et al.	D743,079 S	11/2015	Adair
D695,441 S	12/2013	Lui et al.	D744,723 S	12/2015	Yoo
D695,941 S	12/2013	Rashidi	9,217,560 B2	12/2015	Harbers et al.
D696,446 S	12/2013	Huh	9,222,661 B2	12/2015	Kim et al.
D696,447 S	12/2013	Huh	9,239,131 B1	1/2016	Wronski et al.
D696,448 S	12/2013	Huh	D750,317 S	2/2016	Lui et al.
8,602,601 B2	12/2013	Khazi et al.	9,285,103 B2	3/2016	Van De Ven et al.
D698,067 S	1/2014	Rashidi	9,291,319 B2	3/2016	Kathawate et al.
D698,068 S	1/2014	Rashidi	9,301,362 B2	3/2016	Dohn et al.
8,622,361 B2	1/2014	Wronski	D754,078 S	4/2016	Baldwin et al.
8,632,040 B2	1/2014	Mass et al.	D754,079 S	4/2016	Baldwin et al.
D698,985 S	2/2014	Lopez et al.	D754,605 S	4/2016	McMillan
D699,384 S	2/2014	Rashidi	9,303,812 B2	4/2016	Green et al.
D699,687 S	2/2014	Baldwin et al.	9,310,038 B2	4/2016	Athalye
D700,387 S	2/2014	Snell	9,310,052 B1	4/2016	Shum
8,641,243 B1	2/2014	Rashidi	9,322,543 B2	4/2016	Hussell et al.
8,659,034 B2	2/2014	Baretz et al.	9,347,655 B2	5/2016	Boomgaarden et al.
D700,737 S *	3/2014	Campagna D26/142	9,366,418 B2	6/2016	Gifford
D700,991 S	3/2014	Johnson et al.	9,371,966 B2	6/2016	Rowlette, Jr. et al.
D701,175 S	3/2014	Baldwin et al.	D762,181 S	7/2016	Lin
D701,466 S	3/2014	Clifford et al.	9,395,051 B2	7/2016	Hussell et al.
8,672,518 B2	3/2014	Boomgaarden et al.	D762,906 S	8/2016	Jeswani et al.
D702,867 S	4/2014	Kim et al.	D764,079 S	8/2016	Wu
D703,843 S	4/2014	Cheng	9,417,506 B1	8/2016	Tirosh
8,684,569 B2	4/2014	Pickard et al.	9,423,110 B1	8/2016	Newton et al.
8,696,158 B2	4/2014	Santiago et al.	D766,185 S	9/2016	Hagarty
D705,472 S	5/2014	Huh	D767,199 S	9/2016	Wronski et al.
D705,481 S	5/2014	Zhang et al.	9,447,917 B1	9/2016	Wronski et al.
8,727,582 B2	5/2014	Brown et al.	9,447,953 B2	9/2016	Lawlor
D708,381 S	7/2014	Rashidi	D768,325 S	10/2016	Xu
8,777,449 B2	7/2014	Ven et al.	D768,326 S	10/2016	Guzzini
D710,529 S	8/2014	Lopez et al.	D769,501 S	10/2016	Jeswani et al.
8,801,217 B2	8/2014	Oehle et al.	D770,065 S	10/2016	Tittle
8,820,985 B1	9/2014	Tam et al.	D770,076 S	10/2016	Li et al.
8,833,013 B2	9/2014	Harman	D770,084 S	10/2016	Salomon
8,845,144 B1	9/2014	Davies et al.	9,476,552 B2	10/2016	Myers et al.
D714,989 S	10/2014	Rowlette, Jr. et al.	D770,673 S *	11/2016	Hasan D26/138
8,870,426 B2	10/2014	Biebl et al.	9,488,324 B2	11/2016	Shum et al.
8,888,332 B2	11/2014	Martis et al.	D774,676 S	12/2016	Ng
8,890,414 B2	11/2014	Rowlette, Jr. et al.	D776,324 S	1/2017	Gierl et al.
D721,845 S	1/2015	Lui et al.	D777,967 S	1/2017	Redfern
8,926,133 B2	1/2015	Booth	9,534,751 B2	1/2017	Maglica et al.
8,939,418 B2	1/2015	Green et al.	D778,241 S	2/2017	Holbrook et al.
D722,296 S	2/2015	Taylor	D778,484 S	2/2017	Guzzini
D722,977 S	2/2015	Hagarty	D779,100 S	2/2017	Redfern
D722,978 S	2/2015	Hagarty	D779,105 S	2/2017	Krueckeberg et al.
8,950,898 B2	2/2015	Catalano	D779,711 S *	2/2017	Salomon D26/138
D723,781 S	3/2015	Miner	9,581,302 B2	2/2017	Danesh
D723,783 S	3/2015	Miner	9,599,315 B1	3/2017	Harpenau et al.
D725,359 S	3/2015	Miner	9,605,842 B1	3/2017	Davis
8,967,575 B1	3/2015	Gretz	9,605,910 B2	3/2017	Swedberg et al.
D726,363 S	4/2015	Danesh	D785,228 S	4/2017	Guzzini
			D785,852 S	5/2017	Doust
			D786,472 S	5/2017	Redfern
			D786,473 S	5/2017	Dean
			D786,474 S	5/2017	Fujisawa

(56)

References Cited

U.S. PATENT DOCUMENTS

D788,330 S	5/2017	Johnson et al.	10,753,558 B2	8/2020	Danesh	
D790,102 S	6/2017	Guzzini	10,808,917 B2	10/2020	Harris et al.	
9,673,597 B2	6/2017	Lee	10,816,148 B2	10/2020	Danesh	
9,689,541 B2	6/2017	Wronski	D901,398 S	11/2020	Danesh et al.	
D791,709 S	7/2017	Holton	D901,745 S	11/2020	Yang	
D791,711 S	7/2017	Holton	D902,871 S	11/2020	Danesh et al.	
D791,712 S	7/2017	Holton	D903,605 S	12/2020	Danesh et al.	
9,696,021 B2	7/2017	Wronski	D905,327 S *	12/2020	Williams	D26/142
9,702,516 B1	7/2017	Vasquez et al.	D907,284 S *	1/2021	Danesh	F21S 8/02
D795,820 S	8/2017	Wengreen				D26/138
9,732,904 B1	8/2017	Wronski	D910,223 S	2/2021	Cohen	
9,732,947 B1	8/2017	Christ et al.	10,975,570 B2	4/2021	Shen	
9,739,464 B2	8/2017	Wronski	10,982,829 B2	4/2021	Danesh	
D799,105 S	10/2017	Eder et al.	11,022,259 B2	6/2021	Bailey et al.	
D800,957 S	10/2017	Eder et al.	11,028,982 B2	6/2021	Danesh	
9,791,111 B1	10/2017	Huang et al.	11,047,538 B2	6/2021	Danesh et al.	
9,797,562 B2	10/2017	Dabiet et al.	D924,467 S	7/2021	Danesh et al.	
9,803,839 B2	10/2017	Visser et al.	D925,109 S	7/2021	Danesh et al.	
D805,660 S	12/2017	Creasman et al.	11,060,705 B1	7/2021	Danesh et al.	
D809,176 S	1/2018	Partington	11,067,231 B2	7/2021	Lotfi et al.	
9,860,961 B2	1/2018	Chemel et al.	11,085,597 B2	8/2021	Danesh	
9,863,619 B2	1/2018	Mak	2002/0172047 A1	11/2002	Ashley	
D809,465 S	2/2018	Keirstead	2003/0006353 A1	1/2003	Dinh et al.	
9,903,569 B2	2/2018	O'Brien et al.	2003/0016532 A1	1/2003	Reed	
9,964,266 B2	5/2018	Danesh	2003/0021104 A1	1/2003	Tsao	
D820,494 S	6/2018	Cohen	2003/0161153 A1	8/2003	Patti	
D821,615 S	6/2018	Trice	2004/0001337 A1	1/2004	Defouw et al.	
D821,627 S	6/2018	Ko	2004/0120141 A1	6/2004	Beadle	
9,995,441 B2	6/2018	Power et al.	2004/0156199 A1	8/2004	Rivas et al.	
D822,505 S	7/2018	Gibson et al.	2005/0078474 A1	4/2005	Whitfield	
D824,089 S *	7/2018	Dupras	2005/0225966 A1	10/2005	Hartmann et al.	
D824,494 S	7/2018	Martins et al.	2005/0227536 A1	10/2005	Gamache et al.	
D824,566 S *	7/2018	Santoro	2005/0231962 A1	10/2005	Koba et al.	
D825,829 S	8/2018	Guo	2005/0237746 A1	10/2005	Yiu	
10,041,638 B2	8/2018	Vasquez et al.	2006/0005988 A1	1/2006	Jorgensen	
10,054,274 B2	8/2018	Athalye et al.	2006/0158873 A1	7/2006	Newbold et al.	
D827,903 S	9/2018	Wu	2006/0198126 A1	9/2006	Jones	
D832,218 S	10/2018	Wronski et al.	2006/0215408 A1	9/2006	Lee	
D833,977 S	11/2018	Danesh et al.	2006/0221620 A1	10/2006	Thomas	
10,125,959 B2	11/2018	Cohen	2006/0237601 A1	10/2006	Rinderer	
10,139,059 B2	11/2018	Danesh	2006/0243877 A1	11/2006	Rippel	
D836,976 S	1/2019	Reese et al.	2006/0250788 A1	11/2006	Hodge et al.	
D843,642 S *	3/2019	Mathews	2006/0262536 A1	11/2006	Nevers	
D847,414 S	4/2019	Danesh et al.	2006/0262545 A1	11/2006	Pieprgras et al.	
D847,415 S	4/2019	Danesh et al.	2007/0012847 A1	1/2007	Tai	
10,247,390 B1	4/2019	Kopitzke et al.	2007/0035951 A1	2/2007	Tseng	
D848,375 S	5/2019	Danesh et al.	2007/0121328 A1	5/2007	Mondloch et al.	
10,281,131 B2	5/2019	Cohen	2007/0131827 A1	6/2007	Nevers et al.	
10,295,163 B1	5/2019	Cohen	2007/0185675 A1	8/2007	Papamichael et al.	
D850,695 S	6/2019	Dabiet et al.	2007/0200039 A1	8/2007	Petak	
D851,046 S	6/2019	Peng et al.	2007/0206374 A1	9/2007	Petrakis et al.	
10,408,395 B2	9/2019	Danesh	2008/0002414 A1	1/2008	Miletich et al.	
10,408,396 B2	9/2019	Wronski et al.	2008/0019138 A1	1/2008	Otte et al.	
10,408,436 B2	9/2019	Wronski et al.	2008/0112168 A1	5/2008	Pickard et al.	
D863,661 S	10/2019	Tian et al.	2008/0112170 A1	5/2008	Trott	
D864,468 S	10/2019	Behnke et al.	2008/0112171 A1	5/2008	Patti et al.	
D864,877 S	10/2019	Danesh et al.	2008/0130308 A1	6/2008	Behr et al.	
D864,885 S	10/2019	Kobayashi et al.	2008/0137347 A1	6/2008	Trott et al.	
D867,653 S	11/2019	Gorman	2008/0165545 A1	7/2008	O'Brien	
10,488,000 B2	11/2019	Danesh et al.	2008/0170404 A1	7/2008	Steer et al.	
10,551,044 B2	2/2020	Peng et al.	2008/0224008 A1	9/2008	Dal Ponte et al.	
10,563,850 B2	2/2020	Danesh	2008/0232116 A1	9/2008	Kim	
D877,957 S	3/2020	Kopitzke, IV	2008/0247181 A1	10/2008	Dixon	
10,591,120 B2	3/2020	Bailey et al.	2008/0285271 A1	11/2008	Roberge et al.	
D880,733 S	4/2020	Lo et al.	2009/0003009 A1	1/2009	Tessnow et al.	
D883,562 S	5/2020	Hu	2009/0034261 A1	2/2009	Grove	
D885,648 S	5/2020	Zeng	2009/0080189 A1	3/2009	Wegner	
D885,649 S	5/2020	McLaughlin, III et al.	2009/0086484 A1	4/2009	Johnson	
10,663,127 B2	5/2020	Danesh et al.	2009/0097262 A1	4/2009	Zhang et al.	
10,663,153 B2	5/2020	Nikooyan et al.	2009/0135613 A1	5/2009	Peng	
D888,313 S	6/2020	Xie et al.	2009/0141500 A1	6/2009	Peng	
10,683,994 B2	6/2020	Wronski et al.	2009/0141506 A1	6/2009	Lan et al.	
10,684,003 B2	6/2020	Wronski et al.	2009/0141508 A1	6/2009	Peng	
D890,410 S	7/2020	Stanford et al.	2009/0147517 A1	6/2009	Li	
10,704,745 B2	7/2020	Sherry et al.	2009/0161356 A1	6/2009	Negley et al.	
			2009/0237924 A1	9/2009	Ladewig	
			2009/0280695 A1	11/2009	Sekela et al.	
			2009/0283292 A1	11/2009	Lehr	
			2009/0290343 A1	11/2009	Brown et al.	

(56)

References Cited

U.S. PATENT DOCUMENTS

2010/0002320 A1 1/2010 Minano et al.
 2010/0014282 A1 1/2010 Danesh
 2010/0033095 A1 2/2010 Sadwick
 2010/0061108 A1 3/2010 Zhang et al.
 2010/0110690 A1 5/2010 Hsu et al.
 2010/0110698 A1 5/2010 Harwood et al.
 2010/0110699 A1 5/2010 Chou
 2010/0148673 A1 6/2010 Stewart et al.
 2010/0149822 A1 6/2010 Cogliano et al.
 2010/0165643 A1 7/2010 Russo et al.
 2010/0244709 A1 9/2010 Steiner et al.
 2010/0246172 A1 9/2010 Liu
 2010/0259919 A1 10/2010 Khazi et al.
 2010/0270903 A1 10/2010 Jao et al.
 2010/0277905 A1 11/2010 Janik et al.
 2010/0284185 A1 11/2010 Ngai
 2010/0302778 A1 12/2010 Dabiet et al.
 2010/0328956 A1 12/2010 Zhang
 2011/0043040 A1 2/2011 Porter et al.
 2011/0063831 A1 3/2011 Cook
 2011/0068687 A1 3/2011 Takahasi et al.
 2011/0069499 A1 3/2011 Trott et al.
 2011/0080750 A1 4/2011 Jones et al.
 2011/0116276 A1 5/2011 Okamura et al.
 2011/0121756 A1 5/2011 Thomas et al.
 2011/0134634 A1 6/2011 Gingrich, III et al.
 2011/0134651 A1 6/2011 Berman
 2011/0140633 A1 6/2011 Archenhold
 2011/0170294 A1 7/2011 Mier-Langner et al.
 2011/0194299 A1 8/2011 Crooks et al.
 2011/0216534 A1 9/2011 Tickner et al.
 2011/0226919 A1 9/2011 Fryzek et al.
 2011/0255292 A1 10/2011 Shen
 2011/0267828 A1 11/2011 Bazydola et al.
 2011/0285314 A1 11/2011 Carney et al.
 2012/0020104 A1 1/2012 Biebl et al.
 2012/0074852 A1 3/2012 Delnoij
 2012/0106176 A1 5/2012 Lopez et al.
 2012/0113642 A1 5/2012 Catalano
 2012/0140442 A1 6/2012 Woo et al.
 2012/0140465 A1 6/2012 Rowlette, Jr. et al.
 2012/0162994 A1 6/2012 Wasniewski et al.
 2012/0182744 A1 7/2012 Santiago et al.
 2012/0188762 A1 7/2012 Joung et al.
 2012/0243237 A1 9/2012 Toda et al.
 2012/0250321 A1 10/2012 Blincoe et al.
 2012/0266449 A1 10/2012 Krupa
 2012/0268688 A1 10/2012 Sato et al.
 2012/0287625 A1 11/2012 Macwan et al.
 2012/0305868 A1 12/2012 Callahan et al.
 2012/0314429 A1 12/2012 Plunk
 2013/0009552 A1 1/2013 Page
 2013/0010476 A1 1/2013 Pickard et al.
 2013/0016864 A1 1/2013 Ivey et al.
 2013/0033872 A1 2/2013 Randolph et al.
 2013/0050994 A1 2/2013 Pieper
 2013/0051012 A1 2/2013 Oehle et al.
 2013/0077307 A1 3/2013 Yamamoto
 2013/0083529 A1 4/2013 Gifford
 2013/0141913 A1 6/2013 Sachsenweger
 2013/0155681 A1 6/2013 Nall et al.
 2013/0163254 A1 6/2013 Chang et al.
 2013/0170232 A1 7/2013 Park et al.
 2013/0170233 A1 7/2013 Nezu et al.
 2013/0227908 A1 9/2013 Gulbrandsen et al.
 2013/0258677 A1 10/2013 Fryzek et al.
 2013/0265750 A1 10/2013 Pickard et al.
 2013/0271989 A1 10/2013 Hussell et al.
 2013/0294084 A1 11/2013 Kathawate et al.
 2013/0301252 A1 11/2013 Hussell et al.
 2013/0322062 A1 12/2013 Danesh
 2013/0322084 A1 12/2013 Ebisawa
 2013/0335980 A1 12/2013 Nakasuji et al.
 2014/0029262 A1 1/2014 Maxik et al.
 2014/0036497 A1 2/2014 Hussell et al.

2014/0049957 A1 2/2014 Goelz et al.
 2014/0063776 A1 3/2014 Clark et al.
 2014/0071679 A1 3/2014 Booth
 2014/0071687 A1 3/2014 Tickner et al.
 2014/0140490 A1 5/2014 Roberts et al.
 2014/0063818 A1 6/2014 Randolph et al.
 2014/0233246 A1 8/2014 Lafreniere et al.
 2014/0254177 A1 9/2014 Danesh
 2014/0268836 A1 9/2014 Thompson
 2014/0268869 A1 9/2014 Blessitt et al.
 2014/0299730 A1 10/2014 Green et al.
 2014/0313775 A1 10/2014 Myers et al.
 2014/0321122 A1 10/2014 Domagala et al.
 2014/0347848 A1 11/2014 Pisavadia et al.
 2015/0009676 A1 1/2015 Danesh
 2015/0029732 A1 1/2015 Hatch
 2015/0078008 A1 3/2015 He
 2015/0085500 A1 3/2015 Cooper et al.
 2015/0131301 A1* 5/2015 Ho F21V 19/0055
 2015/0138779 A1 5/2015 Livesay et al.
 2015/0153635 A1 6/2015 Chen et al.
 2015/0184837 A1 7/2015 Zhang et al.
 2015/0198324 A1 7/2015 O'Brien et al.
 2015/0219317 A1 8/2015 Gatof et al.
 2015/0233556 A1 8/2015 Danesh
 2015/0241039 A1 8/2015 Fryzek
 2015/0263497 A1 9/2015 Korcz et al.
 2015/0276185 A1 10/2015 Bailey et al.
 2015/0308662 A1 10/2015 Vice et al.
 2015/0345761 A1 12/2015 Lawlor
 2015/0362159 A1 12/2015 Ludyjan
 2016/0084488 A1 3/2016 Wu et al.
 2016/0209007 A1 7/2016 Belmonte et al.
 2016/0238225 A1 8/2016 Doust
 2016/0308342 A1 10/2016 Witherbee et al.
 2016/0312987 A1 10/2016 Danesh
 2016/0348860 A1 12/2016 Danesh
 2016/0348861 A1 12/2016 Bailey et al.
 2016/0366738 A1 12/2016 Boulanger et al.
 2017/0003007 A1 1/2017 Wronski
 2017/0005460 A1 1/2017 Lee
 2017/0045213 A1 2/2017 Williams et al.
 2017/0059135 A1 3/2017 Jones
 2017/0138576 A1 5/2017 Peng et al.
 2017/0138581 A1 5/2017 Doust
 2017/0167672 A1 6/2017 Stauner et al.
 2017/0167699 A1 6/2017 Schubert et al.
 2017/0198896 A1 7/2017 May
 2017/0284616 A1 10/2017 Coakley et al.
 2017/0307188 A1 10/2017 Oudina et al.
 2017/0307198 A1 10/2017 Shah et al.
 2018/0112857 A1 4/2018 Wronski et al.
 2018/0142871 A1 5/2018 Morales
 2018/0216809 A1 8/2018 Cohen
 2018/0224095 A1 8/2018 Cohen
 2018/0231197 A1 8/2018 Danesh
 2018/0283677 A1 10/2018 Cohen
 2018/0372284 A1 12/2018 Danesh et al.
 2019/0032874 A1 1/2019 Bonnetto et al.
 2019/0041050 A1 2/2019 Cairns et al.
 2019/0049080 A1 2/2019 Danesh
 2019/0063701 A1 2/2019 Lotfi et al.
 2019/0093836 A1 3/2019 Danesh
 2020/0182420 A1 6/2020 Cohen et al.
 2020/0291652 A1 9/2020 Shen
 2020/0355334 A1 11/2020 Shen et al.
 2020/0393118 A1 12/2020 Danesh et al.
 2021/0010647 A1 1/2021 Danesh et al.
 2021/0010663 A1 1/2021 Nikooyan et al.
 2021/0033268 A1 2/2021 Danesh
 2021/0080084 A1 3/2021 Danesh et al.
 2021/0222845 A1 7/2021 Kopitzke et al.

FOREIGN PATENT DOCUMENTS

CA 2691480 C 4/2012
 CA 2734369 A1 10/2013
 CA 2561459 A1 11/2013

(56)

References Cited

FOREIGN PATENT DOCUMENTS

CA	2815067		11/2013
CA	2848289	A1	10/2014
CA	2998173		7/2018
CN	2182475	Y	11/1994
CN	201059503	Y	5/2008
CN	201259125	Y	6/2009
CN	101608781	A	12/2009
CN	201636626	U	11/2010
CN	102062373	A	5/2011
CN	202014067	U	10/2011
CN	202392473	U	8/2012
CN	202733693	U	2/2013
CN	103307518	A	9/2013
CN	103322476	A	9/2013
CN	203202661	U	9/2013
CN	203215483	U	9/2013
CN	101498411	B	11/2013
CN	203273663	U	11/2013
CN	203297980	U	11/2013
CN	203628464	U	12/2013
CN	203641919	U	6/2014
CN	204300818	U	4/2015
CN	104654142	A	5/2015
CN	204513161	U	7/2015
CN	204611541	U	9/2015
CN	204786225	U	11/2015
CN	204829578	U	12/2015
CN	103712135	B	4/2016
CN	205606362	U	9/2016
CN	206130742	U	4/2017
CN	103154606	B	5/2017
CN	206222112	U	6/2017
CN	107013845	A	8/2017
CN	107084343	A	8/2017
DE	9109828	U1	2/1992
DE	199 47 208		5/2001
EP	1 589 289		10/2005
EP	1 672 155	A1	6/2006
EP	1688663		8/2006
EP	2 095 938	A1	2/2008
EP	2 306 072	A1	4/2011
EP	2 453 169	A2	5/2012
EP	2 193 309	B1	7/2012
EP	2 735 787	A1	5/2014
EP	3 104 024	A1	12/2016
GB	2325728		12/1998
GB	2427020	A	12/2006
GB	2466875		7/2010
GB	2471929		1/2014
GB	2509772	A	7/2014
JP	H02113002	U	9/1990
JP	2007091052	A	4/2007
JP	2007265961	A	10/2007
JP	2011060450	A2	3/2011
JP	2012064551	A2	3/2012
JP	2015002027	A2	1/2015
JP	2015002028	A2	1/2015
JP	2016219335	A	12/2016
JP	2017107699	A2	6/2017
KR	1020110008796	A	1/2011
KR	1020120061625	A	6/2012
MX	2011002947	A	9/2011
TW	474382	U	1/2002
WO	WO 2013/128896	A1	9/2013
WO	WO 2015/000212	A1	1/2015
WO	WO 2016152166	A2	9/2016

OTHER PUBLICATIONS

Acrich COB Zhaga Module, Product Description, Seoul Semiconductor, Nov. 11, 2016, 39 pages.

<<https://www.zhagastandard.org/books/book18/>>, Mar. 2017, 5 pages. Accessed on May 14, 2018.

Bortz, J. C. et al., "Optimal design of a nonimaging TIR doublet lens for an illumination system using an LED source", Proc. SPIE 5529, Nonimaging Optics and Efficient Illumination Systems, (Sep. 29, 2004); doi: 10.1117/12.562598; <https://doi.org/10.1117/12.562598>, 10 pages.

Bxuv.GuideInfo, Fire Resistance Ratings—ANSI/UL 263, UL Online Certifications Directory, last updated Nov. 3, 2016, 27 pages.

Ceyy.GuideInfo, Outlet Boxes and Fittings Certified for Fire Resistance, UL Online Certifications Directory, last updated May 16, 2013, 2 pages.

Canadian Office Action dated Dec. 23, 2013 from Canadian Application No. 2,778,581, 3 pages.

Canadian Office Action dated Mar. 22, 2016 from Canadian Application No. 2,879,629, 4 pages.

Canadian Office Action dated Dec. 6, 2016 from Canadian Application No. 2,879,629, 3 pages.

Canadian Office Action dated Mar. 9, 2017 from Canadian Application No. 2,931,588, 5 pages.

Canadian Office Action dated Feb. 1, 2016 from Canadian Application No. 2,879,486, 5 pages.

Canadian Office Action dated Jun. 12, 2017 from Canadian Application No. 2,927,601, 4 pages.

Canadian Office Action dated Aug. 11, 2017 from Canadian Application No. 2,941,051, 4 pages.

Carlson® Zip Box® Blue™ Switch and Outlet Boxes, Product Brochure, <http://www.carlonsales.com/brochures.php>, Jun. 20, 2006, 22 pages.

Cree LED Lamp Family Sales Sheet—Better light is beautiful light, Apr. 24, 2017, 2 pages.

DME Series Installation Instructions, Oct. 18, 2011, 2 pages.

DMF, Inc., "dmfLIGHTING: LED Recessed Lighting Solutions," Info sheets, Mar. 15, 2012, 4 pages.

DMF, Inc., "dmfLIGHTING: LED Recessed Downlighting," DRD2 Product Brochure, Oct. 23, 2014, 50 pages.

DMF, Inc., "dmfLIGHTING: LED Recessed Downlighting," Product Catalog, Aug. 2012, 68 pages.

Dross, O. et al., "Review of SMS design methods and real-world applications", Proc. SPIE 5529, Nonimaging Optics and Efficient Illumination Systems, (Sep. 29, 2004); doi: 10.1117/12.561336; <https://doi.org/10.1117/12.561336>, 14 pages.

Final Office Action dated Apr. 27, 2016 from U.S. Appl. No. 14/184,601, 19 pages.

Final Office Action dated Jul. 26, 2017 from U.S. Appl. No. 14/184,601, 18 pages.

Final Office Action dated Jan. 29, 2016 from U.S. Appl. No. 14/183,424, 21 pages.

Final Office Action dated Jun. 23, 2016 from U.S. Appl. No. 13/484,901, 18 pages.

Final Office Action dated Apr. 2, 2015 from U.S. Appl. No. 13/484,901, 13 pages.

Halo, Halo LED H4 H7 Collection, SustainabLEDesign, Cooper Lighting, (emphasis on p. 18 "H7 Collection LED Modules—Halo LED H7 Module Features,") Mar. 28, 2012, 52 pages.

Halo, H7 LED Downlight Trims 49x Series, 6-inch LED Trims for Use with M17x LED Modules, Cooper Lighting, ADV110422, rev. Aug. 12, 2011, 15 pages.

Halo, LED Module ML706x, Cooper Lighting, General Installation for All Modules/p. 1; Tether Installation/pp. 2-3; Installation into Halo H750x Series LED—only (Non-Screw Based), Recessed Fixture, p. 4, Oct. 20, 2009, 4 pages.

Medvedev, V et al., "Uniform LED illuminator for miniature displays," Proc. SPIE 3428, Illumination and Source Engineering, (Oct. 20, 1998); doi: 10.1117/12.327957; <https://doi.org/10.1117/12.327957>, 13 pages.

"Membrane Penetrations in Fire-Resistance Rated Walls," https://www.ul.com/wp-content/uploads/2014/04/ul_MembranePenetrations.pdf, Issue 1, 2009, published Feb. 26, 2010, 2 pages.

"Metallic Outlet Boxes," UL 514A, Underwriters Laboratories, Inc., Feb. 16, 2004 (Title Page Reprinted Aug. 10, 2007), 106 pages.

"Metallic and Non-metallic Outlet Boxes Used in Fire-rated Assembly," <https://iaeimagazine.org/magazine/2000/09/16/metallic-and-non-metallic-outlet-boxes-used-in-fire-rated-assembly/>, Sep. 16, 2000, 5 pages.

(56)

References Cited

OTHER PUBLICATIONS

- Notice of Allowance dated Mar. 26, 2018 for U.S. Appl. No. 14/184,601, 10 pages.
- Non-Final Office Action dated Mar. 15, 2010 from U.S. Appl. No. 12/100,148, 8 pages.
- Non-Final Office Action dated Apr. 30, 2010 from U.S. Appl. No. 12/173,232, 13 pages.
- Non-Final Office Action dated Sep. 5, 2014 from U.S. Appl. No. 13/791,087, 8 pages.
- Non-Final Office Action dated Jul. 20, 2015 from U.S. Appl. No. 14/184,601, 16 pages.
- Non-Final Office Action dated Dec. 15, 2016 from U.S. Appl. No. 14/184,601, 18 pages.
- Non-Final Office Action dated Feb. 6, 2018 from U.S. Appl. No. 15/167,682, 9 pages.
- Non-Final Office Action dated Sep. 15, 2015 from U.S. Appl. No. 13/484,901, 16 pages.
- Non-Final Office Action dated Oct. 16, 2014 from U.S. Appl. No. 13/484,901, 11 pages.
- Non-Final Office Action dated Sep. 6, 2017 from U.S. Appl. No. 14/726,064, 8 pages.
- Non-Final Office Action dated May 17, 2017 from U.S. Appl. No. 14/183,424, 20 pages.
- Non-Final Office Action dated Jun. 2, 2015 from U.S. Appl. No. 14/183,424, 20 pages.
- Non-Final Office Action dated Apr. 12, 2018 for U.S. Appl. No. 29/638,259, 5 pages.
- Non-Final Office Action dated May 16, 2018 for U.S. Appl. No. 15/132,875, 18 pages.
- Notice of Allowance dated Jan. 30, 2015 from U.S. Appl. No. 13/791,087, 9 pages.
- Notice of Allowance dated Jan. 16, 2015 from U.S. Appl. No. 29/467,026, 9 pages.
- Notice of Allowance dated Oct. 21, 2016 from U.S. Appl. No. 13/484,901, 7 pages.
- Notice of Allowance dated Mar. 24, 2016 from U.S. Appl. No. 14/247,149, 8 pages.
- Notice of Allowance dated May 22, 2018 from U.S. Appl. No. 14/183,424, 9 pages.
- Notice of Allowance dated May 10, 2018 from U.S. Appl. No. 14/726,064, 7 pages.
- Notice of Allowance dated Aug. 23, 2017 from Canadian Application No. 2,879,629, 1 page.
- "Outlet Boxes for Use in Fire Rated Assemblies," https://www.ul.com/wp-content/uploads/2014/04/UI_outletboxes.pdf, Apr. 2007, 2 pages.
- Parkyn, W. A. et al., "New TIR lens applications for light-emitting diodes", Proc. SPIE 3139, Nonimaging Optics: Maximum Efficiency Light Transfer IV, (Oct. 3, 1997); doi: 10.1117/12.290217, 7 pages.
- Schreiber, P et al., "Microoptics for homogeneous LED-illumination", Proc. SPIE 6196, Photonics in Multimedia, 61960P (Apr. 21, 2006); doi: 10.1117/12.663084; <https://doi.org/10.1117/12.663084>, 11 pages.
- Zhen, Y. et al., "The optimal design of TIR lens for improving LED illumination uniformity and efficiency", Proc. SPIE 6834, Optical Design and Testing III, 68342K (Nov. 28, 2007); doi: 10.1117/12.756101, 9 pages.
- Zou, H et al., "58.1: Single-Panel LCOS Color Projector with LED Light Sources", SID Symposium, vol. 36, Issue 1, 4 pages (May 2005).
- Notice of Allowance dated Sep. 21, 2018 from U.S. Appl. No. 29/645,941, 5 pages.
- "Advanced LED Solutions," Imtra Marine Lighting. Jun. 17, 2011. 39 pages.
- "Portland Bi-Color, Warm White/Red," item:ILIM30941.Imtra Marine Products. 2012. 3 pages. Accessed at <http://www.imtra.com:80/0ade25fb-3218-4cae-a926-6abe64ffd93a/lighting-light-fixtures-downlights-3-to-4-inches-detail.htm> on Jan. 25, 2013.
- "Cree LMH2 LED Modules," Mouser Electronics. Accessed at www.mouser.com/new/cree/creelmh2 on Sep. 9, 2012. 2 pages.
- "Cree LMH2 LED Module with TrueWhite Technology," Cree Product Family Data Sheet. Dec. 21, 2011. 3 pages.
- "Cree LMH2 LED Modules Design Guide," Cree Product Design Guide. 2011. 20 pages.
- "Undercabinet Pucks, Xyris Mini LED Puck Light," ELCO Lighting. Sep. 2018. 1 page.
- "LED Undercabinet Pocket Guide," ELCO Lighting. Nov. 2, 2016. 12 pages.
- "VERSI LED Mini Flush," Lithonia Lighting. Sep. 2013. 6 pages.
- Notice of Allowance dated Oct. 4, 2018 from U.S. Appl. No. 15/947,065, 9 pages.
- Notice of Allowance dated Sep. 19, 2018 from U.S. Appl. No. 15/167,682, 7 pages.
- Non-Final Office Action dated Jun. 25, 2018 for U.S. Appl. No. 29/541,565, 10 pages.
- Non-Final Office Action dated Oct. 24, 2018 for U.S. Appl. No. 15/688,266, 14 pages.
- OneFrame Recessed LED Downlight. Dmflighting.com. Published Jun. 6, 2018. Retrieved at <https://www.dmflighting.com/product/oneframe> on Jun. 6, 2018. 11 pages.
- Notice of Allowance dated Oct. 9, 2018 from U.S. Appl. No. 29/653,142, 7 pages.
- International Search Report and Written Opinion in PCT/US2018/048357 dated Nov. 14, 2018, 13 pages.
- Notice of Allowance dated Nov. 27, 2018 from U.S. Appl. No. 15/167,682, 11 pages.
- Non-Final Office Action dated Dec. 5, 2018 from U.S. Appl. No. 14/942,937, 13 pages.
- International Search Report and Written Opinion in International Patent Application No. PCT/US18/39048 dated Dec. 14, 2018. 24 pages.
- Notice of Allowance dated Jan. 2, 2019 from U.S. Appl. No. 29/541,565, 6 pages.
- RACO 4 in-A882:C958n. Octagon Welded Concrete Ring, 3-1/2 in. Deep with 1/2 and 3/4 in. Knockouts and includes 890 cover (20-Pack). Model # 280. Accessed at <https://www.homedepot.com/p/RACO-4-in-Octagon-Welded-Concrete-Ring-3-1-2-in-Deep-with-1-2-and-3-4-in-Knockouts-and-includes-890-cover-20-Pack-280/203638679> on Jan. 18, 2019. 3 pages.
- RACO 4 in. Octagon Welded Concrete Ring, 6 in. Deep with 1/2 and 3/4 in. Knockouts (10-Pack). Model # 276. Accessed at <https://www.homedepot.com/p/RACO-4-in-Octagon-Welded-Concrete-Ring-6-in-Deep-with-1-2-and-3-4-in-Knockouts-10-Pack-276/203638675> on Jan. 16, 2019. 4 pages.
- Notice of Allowance dated Feb. 8, 2019 from U.S. Appl. No. 29/541,565, 5 pages.
- Non-Final Office Action dated Feb. 7, 2019 from U.S. Appl. No. 16/200,393, 32 pages.
- Notice of Allowance dated Jan. 28, 2019 from U.S. Appl. No. 29/664,471, 8 pages.
- Non-Final Office Action dated Jul. 24, 2018 from U.S. Appl. No. 29/638,259, 5 pages.
- Final Office Action dated Mar. 15, 2019 from U.S. Appl. No. 15/132,875, 15 pages.
- International Search Report and Written Opinion in International Patent Application No. PCT/US18/62868 dated Mar. 14, 2019, 13 pages.
- CS&E PCT Collaborative Search and Examination Pilot Upload Peer Contribution in International Patent Application No. PCT/US18/62868 mailed Mar. 14, 2019, 61 pages.
- Notice of Allowance dated Apr. 1, 2019 from U.S. Appl. No. 15/167,682, 7 pages.
- Non-Final Office Action dated Apr. 4, 2019 from U.S. Appl. No. 29/678,482, 8 pages.
- Notice of Allowance dated Apr. 8, 2019 from U.S. Appl. No. 29/653,142, 8 pages.
- Notice of Allowance dated Apr. 17, 2019 from U.S. Appl. No. 29/678,478, 7 pages.
- International Search Report and Written Opinion in International Patent Application No. PCT/US18/67614 dated Apr. 25, 2019, 20 pages.

(56)

References Cited

OTHER PUBLICATIONS

- CS&E PCT Collaborative Search and Examination Pilot Upload Peer Contribution in International Patent Application No. PCT/US18/67614 dated Apr. 24, 2019, 53 pages.
- Specification & Features 4" Octagonal Concrete Box Covers. Orbit Industries, Inc. Accessed at <https://www.orbitelectric.com> on May 6, 2019. 1 page.
- 4" Octagon Concrete Boxes and Back Plates. Appleton. Accessed at www.appletonelec.com on May 6, 2019. 1 page.
- RACO Commercial, Industrial and Residential Electrical Products. Hubbell. Accessed at www.Hubbell-RTB.com on May 6, 2019. 356 pages.
- Imtra Marine Lighting 2008 Catalog. 40 pages.
- Imtra Marine Lighting 2009 Catalog. 32 pages.
- Imtra Marine Lighting Spring 2007 Catalog. 36 pages.
- Final Office Action dated Jun. 6, 2019 from U.S. Appl. No. 15/688,266, 7 pages.
- Non-Final Office Action dated Jun. 11, 2019 from U.S. Appl. No. 15/901,738, 6 pages.
- Notice of Allowance dated Jun. 12, 2019 from U.S. Appl. No. 16/016,040, 8 pages.
- Cooper Lighting Halo ML56 LED System Product Sheet. Mar. 2, 2015. Accessed at http://www.cooperindustries.com/content/dam/public/lighting/products/documents/halo/spec_sheets/halo-ml56600-80cri-141689-sss.pdf. 8 pages.
- KWIKBRACE® New Construction Braces for Lighting Fixtures or Ceiling Fans 1-1/2 in. Depth. Hubbell. Accessed at <https://hubbellcdn.com/specsheet/926.pdf> on Jun. 27, 2019. 1 page.
- IC1JB Housing 4" IC-Rated New Construction Junction Box Housing. AcuityBrands. Accessed at <https://www.acuitybrands.com/en/products/detail/845886/juno/ic1jb-housing/4-ic-rated-new-construction-junction-box-housing> on Jun. 27, 2019.
- Ex-Parte Quayle Action mailed Jun. 27, 2019 from U.S. Appl. No. 29/683,730, 5 pages.
- Notice of Allowance dated Jul. 31, 2019 from U.S. Appl. No. 15/167,682, 7 pages.
- Supplemental Notice of Allowance dated Aug. 5, 2019 from U.S. Appl. No. 15/947,065, 2 pages.
- International Search Report and Written Opinion in International Patent Application No. PCT/US19/32281 dated Aug. 2, 2019, 18 pages.
- Notice of Allowance dated Sep. 11, 2019 from U.S. Appl. No. 29/653,142, 6 pages.
- Notice of Allowance dated Sep. 19, 2019 from U.S. Appl. No. 16/016,040, 7 pages.
- Corrected Notice of Allowance dated Sep. 27, 2019 from U.S. Appl. No. 15/167,682, 2 pages.
- Final Office Action dated Sep. 27, 2019 from U.S. Appl. No. 16/200,393, 34 pages.
- Notice of Allowance dated Feb. 15, 2019 from U.S. Appl. No. 15/947,065, 9 pages.
- Notice of Allowance dated Oct. 1, 2019 from U.S. Appl. No. 14/942,937, 7 pages.
- Final Office Action dated Oct. 3, 2019 from U.S. Appl. No. 29/678,482, 6 pages.
- Delhi Rehab & Nursing Facility ELM16-70884. Vertex Innovative Solutions Feb. 25, 2016. 89 pages.
- SlimSurface surface mount downlighting. Philips Lightolier 2018. 8 pages.
- Be seen in the best light. Lightolier by signify. Comprehensive 2019 Lighting Catalog. 114 pages.
- Corrected Notice of Allowance dated Oct. 10, 2019 from U.S. Appl. No. 16/016,040, 2 pages.
- Cree® LMR2 LED Module. Product Family Data Sheet Cree 2011. 3 pages.
- Notice of Allowance dated Oct. 16, 2019 from U.S. Appl. No. 15/132,875, 12 pages.
- International Search Report and Written Opinion in International Patent Application No. PCT/US2019/036477 dated Oct. 17, 2019, 15 pages.
- ML56 LED Lighting System 600 / 900 / 1200 Series Halo. Cooper Lighting Brochure 2015. Accessed at <https://images.homedepot-static.com/catalog/pdfImages/06/06d28f93-4bf6-45be-a35a-a0239606f227.pdf>. 41 pages.
- Switch and Outlet Boxes and Covers Brochure. Appelton 2010. 77 pages.
- Non-Final Office Action dated Dec. 30, 2019 from U.S. Appl. No. 16/653,497, 8 pages.
- Notice of Allowance dated Feb. 5, 2020 from U.S. Appl. No. 15/901,738, 8 pages.
- Notice of Allowance dated Feb. 5, 2020 from U.S. Appl. No. 29/678,482, 13 pages.
- Maxim Lighting Wafer Trifold Brochure LMXBRO1711 2017. Accessed at <https://www.maximlighting.com/Upload/download/brochure/pdf/LMXBRO1711.pdf> on Feb. 13, 2020. 2 pages.
- Maxim Convert Fixture. LMXCAT1805 Maxim Main Catalog 2018 p. 639.
- Maxim Wafer. LMXCAT1805 Maxim Main Catalog 2018 pp. 636-638.
- Maxim Lighting Trim Trifold LMXBRO1905 2019. Accessed at <https://www.maximlighting.com/Upload/download/brochure/pdf/LMXBRO1905.pdf> on Feb. 13, 2020. 2 pages.
- International Search Report and Written Opinion in International Patent Application No. PCT/US2019/054220 dated Feb. 24, 2020, 23 pages.
- Final Office Action dated Mar. 17, 2020 for U.S. Appl. No. 29/653,142, 13 pages.
- LED Book Price Guide 2012. DMF Light. Issued Jun. 26, 2013. 3 pages.
- DLER411 4" Recessed LED Retrofit Module. DMF Light. Issued Jun. 15, 2011. 1 page.
- DLEI411 4" Recessed LED New Construction, IC. DMF Light. Issued Nov. 30, 2011. 1 page.
- DLEIR411 4" Recessed LED Remodel, IC. DMF Light. Issued Jun. 15, 2011. 1 page.
- 3 & 4" DLE Series LED Sample Case Now Available. DMF Light. Issued Jan. 6, 2012. 1 page.
- DLEI3 3" Recessed LED New Construction, IC. DMF Light. Issued Nov. 30, 2011. 2 pages.
- Ridgway-Barnes, SlimSurface LED Downlight: One of the thinnest LED surface mount downlights in the market. Philips Lighting Blog. Oct. 28, 2014. Accessed at <http://applications.nam.lighting.philips.com/blog/index.php/2014/10/28/slimsurface-led-downlight-one-of-the-thinnest-led-surface-mount-downlights-in-the-market/>. 3 pages.
- SlimSurface LED S5R, S7R & S10R Round 5", 7" and 10" Apertures. Lightolier by Signify. Nov. 2018. 9 pages.
- Non-Final Office Action dated Apr. 2, 2020 for U.S. Appl. No. 16/522,275, 21 pages.
- Notice of Allowance dated May 18, 2020 from U.S. Appl. No. 15/901,738, 7 pages.
- Non-Final Office Action dated May 20, 2020 for U.S. Appl. No. 15/688,266, 6 pages.
- Non-Final Office Action dated May 26, 2020 for U.S. Appl. No. 16/719,361, 10 pages.
- Maxim Lighting International, "Wafer LED 7" RD 3000K Wall/Flush Mount", undated.
- Maxim Lighting International, "Convert LED Flush Mount", undated.
- Maxim Lighting International, "Views of the Wafer Flush Mount", undated.
- Maxim Lighting International, "Product/Drawing Specification Sheet", undated.
- International Search Report and Written Opinion in PCT/US2020/017331 dated Jun. 22, 2020, 16 pages.
- Taiwan Office Action and translation thereof dated Jun. 12, 2020 from Taiwan Application No. 108116564, 8 pages.
- Access Lighting Installation Instructions. No. 20870LEDD/20871LEDD/20872LEDD. Dec. 16, 2019. 2 pages.
- Model No. 20870LEDD-WH/ACR Infinite Specification Sheet. Access Lighting. Apr. 9, 2020. 1 page.
- Notice of Allowance dated Apr. 9, 2020 from U.S. Appl. No. 16/653,497, 7 pages.

(56)

References Cited

OTHER PUBLICATIONS

Notice of Allowance dated Jul. 10, 2020 from U.S. Appl. No. 29/694,475, 6 pages.

Appeal 2016-007893 (2017 PTAB) for U.S. Appl. No. 29/465,550, now U.S. Pat. No. D. 822,505, Board Decision—Examiner Reversed; Decision reversing rejection under 35 USC 112, Oct. 2, 2017, 6 pages.

Corrected Notice of Allowability dated Oct. 25, 2018 from U.S. Appl. No. 14/183,424, 3 pages.

Dmf DRD2 Recessed LED Downlight General Retrofit Junction Box Dated: Dec. 18, 2015 Downloaded Jul. 28, 2018, from <https://www.alconlighting.com/specsheets/DMF/DRD2-Junction-Box-Retrofit-Spec-Sheet.pdf>, 6 pages.

Dmf DRD2 Recessed LED Downlight General New Construction 4", 5", 6" Aperture Dated: Aug. 31, 2016 Downloaded Jul. 28, 2018, from https://www.cansandfans.com/sites/default/files/DRD2-General-New-Construction-Spec-Sheet_7_0.pdf, 9 pages.

David's Bridal, Inc. v. Jenny Yoo Collections, Inc., PGR2016-00041 (PTAB 2017), U.S. Pat. No. D. 744,723; Decision Denying Institution of Post-Grant Review Entered Feb. 22, 2017, 19 pages.

Mar. 5, 2016—The DMF Lighting DRD2 Recessed LED Downlight General Retrofit Junction Box—Wet Location Rated is the ideal solution for Commercial LED recessed lighting retrofit applications. web cache <https://www.alconlighting.com/dmf-drd2m.html> (downloaded Jul. 28, 2018), 6 pages.

Ex Parte Quayle Office Action dated Oct. 16, 2018 for U.S. Appl. No. 29/663,037, 7 pages.

Notice of Allowance dated Nov. 19, 2018 from U.S. Appl. No. 29/663,037, 5 pages.

Notice of Allowance dated Nov. 15, 2018 from U.S. Appl. No. 29/663,040, 5 pages.

Skechers v. Nike, No. 2017-00620, Final Written Decision; Jun. 28, 2018.

Skechers USA, Inc., v. Nike, Inc., IPR2016-00871 (PTAB 2016), U.S. Pat. No. D. 725,359; Decision Denying Institution of Inter Partes Review, Sep. 29, 2016, 31 pages.

Skechers v. Nike, No. 2017-00621, U.S. Pat. No. D. 723,781, Final Written Decision; Jun. 28, 2018, 31 pages.

LED modules advance in performance, standardization questions persist (Magazine). LEDs Magazine. Oct. 29, 2013. Accessed at <https://www.ledsmagazine.com/leds-ssl-design/modular-light-engines/article/16695073/led-modules-advance-in-performance-standardization-questions-persist-magazine>. 9 pages.

Notice of Allowance dated Jul. 20, 2020 from U.S. Appl. No. 29/648,046, 5 pages.

Octagon Concrete Box Cover with (3) 1/2 in. & (2) 3/4 in. Conduit Knockouts. Garvin. Accessed at https://www.garvinindustries.com/covers-and-device-rings/concrete-slab-box-covers-adaptor-rings/flat-covers-all-styles/cbp?gclid=Cj0KCQjw9b_4BRCMARIsADMUIypJc0K80UHdDTI9C5m4BDzR3U87PRYV1NdQIBFxEWQ21_3otTCTqEkaAi_DEALw_wcB on Jul. 20, 2020. 1 page.

Notice of Allowance dated Jul. 28, 2020 from U.S. Appl. No. 16/719,361, 8 pages.

Notice of Allowance dated Jul. 29, 2020 from U.S. Appl. No. 16/522,275, 8 pages.

Non-Final Office Action dated Aug. 19, 2020 for U.S. Appl. No. 16/886,365, 16 pages.

Notice of Allowance dated Sep. 8, 2020 from U.S. Appl. No. 29/678,482, 5 pages.

Corrected Notice of Allowance dated Sep. 11, 2020 from U.S. Appl. No. 16/719,361, 2 pages.

Canadian Office Action in Application No. 2931588 dated Aug. 13, 2020, 5 pages.

Corrected Notice of Allowance dated Sep. 14, 2020 from U.S. Appl. No. 16/522,275, 2 pages.

Notice of Allowance dated Sep. 22, 2020 from U.S. Appl. No. 29/683,730, 6 pages.

Notice of Allowance dated Sep. 22, 2020 from U.S. Appl. No. 29/653,142, 6 pages.

Notice of Allowance dated Oct. 27, 2020 from U.S. Appl. No. 29/648,046, 5 pages.

Notice of Allowance dated Oct. 27, 2020 from U.S. Appl. No. 29/694,475, 5 pages.

Notice of Allowance dated Nov. 10, 2020 from U.S. Appl. No. 29/688,143, 6 pages.

Notice of Allowance dated Nov. 10, 2020 from U.S. Appl. No. 29/688,172, 6 pages.

Notice of Allowance Dated Dec. 2, 2020 from U.S. Appl. No. 29/746,262, 6 pages.

Non-Final Office Action dated Nov. 30, 2020 from U.S. Appl. No. 17/000,702, 7 pages.

International Search Report and Written Opinion in PCT/US2020/050767 dated Dec. 9, 2020, 25 pages.

Non-Final Office Action dated Dec. 16, 2020 from U.S. Appl. No. 17/080,080, 28 pages.

Petition for Inter Partes Review of U.S. Pat. No. 9,964,266 Pursuant to 37 C.F.R. § 42.100 et seq. *AMP Plus Inc. dbd ELCO Lighting v. DMF, Inc.*, IPR2019-01094 filed May 17, 2019. 108 pages.

IPR2019-01094 Exhibit 1001. U.S. Pat. No. 9,964,266 (“the ‘266 Patent”). 14 pages.

IPR2019-01094 Exhibit 1002. Declaration of Eric Bretschneider, Ph.D. (“Bretschneider”). 107 pages.

IPR2019-01094 Exhibit 1003. Curriculum Vitae of Dr. Bretschneider. 11 pages.

IPR2019-01094 Exhibit 1004. Excerpts from the File History of U.S. Pat. No. 9,964,266. 105 pages.

IPR2019-01094 Exhibit 1005. Imtra 2011 Marine Lighting Catalog—Advanced LED Solutions (“Imtra 2011”). 40 pages.

IPR2019-01094 Exhibit 1006. Imtra 2007 Marine Lighting Catalog (“Imtra 2007”). 36 pages.

IPR2019-01094 Exhibit 1007. U.S. Pat. No. 9,366,418 (“Gifford”). 9 pages.

IPR2019-01094 Exhibit 1008. Declaration of Colby Chevalier (“Chevalier”). 89 pages.

IPR2019-01094 Exhibit 1009. U.S. Pat. No. 7,102,172 (“Lynch”). 41 pages.

IPR2019-01094 Exhibit 1010. Illuminating Engineering Society, ANSI RP-16-10, Nomenclature and Definitions for Illuminating Engineering (approved as an American National Standard Jul. 15, 2005, approved by the IES Board of Directors Oct. 15, 2005). 4 pages.

IPR2019-01094 Exhibit 1011. Underwriters Laboratories Inc. Standard for Safety, Standard UL-8750, entitled Light Emitting Diode (LED) Equipment for Use in Lighting (1st ed. 2009). 5 pages.

IPR2019-01094 Exhibit 1012. Celanese CoolPoly® D5502 Thermally Conductive Liquid Crystalline Polymer Specification (“CoolPoly”). 1 page.

IPR2019-01094 Exhibit 1013. Illuminating Engineering Society of North America, IES Lighting Handbook (John E. Kaufman and Howard Haynes eds., Application vol. 1981) (“Lighting Handbook”). 5 pages.

IPR2019-01094 Exhibit 1014. California Energy Commission, PIER Lighting Research Program: Project 2.3 Low-profile LED Luminaires Final Report (Prepared by Lighting Research Center, Jan. 2005) (“PIER LRP”). 70 pages.

IPR2019-01094 Exhibit 1015. Jim Sinopoli, Using DC Power to Save Energy and End the War on Currents, GreenBiz (Nov. 15, 2012), <https://www.greenbiz.com/news/2012/11/15/using-dc-power-save-energy-end-war-currents> (“Sinopoli”). 6 pages.

IPR2019-01094 Exhibit 1016. Robert W. Johnson, “Thought Leadership White Paper: AC Versus DC Power Distribution” (Nov. 2012) (“Johnson”). 10 pages.

IPR2019-01094 Exhibit 1017. Lumileds, Luxeon Rebel General Purpose Product Datasheet, Specification DS64 (2016) (“Luxeon Rebel”). 26 pages.

IPR2019-01094 Exhibit 1018. U.S. Pat. No. 8,454,204 (“Chang”). 11 pages.

IPR2019-01094 Exhibit 1019. U.S. Department of Energy, CALiPER Benchmark Report: Performance of Incandescent A-Type and Decorative Lamps and LED Replacements (prepared by Pacific National Laboratory, Nov. 2008) (“CALiPER 2008”). 25 pages.

(56)

References Cited

OTHER PUBLICATIONS

IPR2019-01094 Exhibit 1020. U.S. Pat. No. 3,836,766 (“Auerbach”). 13 pages.

IPR2019-01094 Exhibit 1021. U.S. Department of Energy, CALiPER Application Summary Report 16: LED BR30 and R30 Lamps (prepared by Pacific Northwest National Laboratory, Jul. 2012) (“CALiPER 2012”). 26 pages.

IPR2019-01094 Exhibit 1022. Sandia National Laboratories, Sandia Report: “The Case for a National Research Program on Semiconductor Lighting” (Jul. 2000) (“Haiz”). 24 pages.

IPR2019-01094 Exhibit 1023. Sylvania, Post Top Street Light LED Retrofit Kit Specification, LED40POST (2009) (“Sylvania”). 4 pages.

IPR2019-01094 Exhibit 1024. Webster’s New Collegiate Dictionary (1973) (“Webster’s”). 2 pages.

IPR2019-01094 Exhibit 1025. 3M Wire Connectors and Tools Catalog 2013 (“3M Catalog”). 22 pages.

IPR2019-01094 Exhibit 1026. Wakefield Semiconductor Heat Sinks and Thermal Products 1974 Catalog (“Wakefield”). 3 pages.

IPR2019-01094 Exhibit 1027. U.S. Department of Energy, Solid-State Lighting Research and Development Portfolio: Multi-Year Program Plan FY’07-FY’12 (prepared by Navigant Consulting, Inc., Mar. 2006) (“DOE 2006”). 129 pages.

IPR2019-01094 Exhibit 1028. U.S. Department of Energy, Solid-State Lighting ResearA1023:C1043elopment: Multi-Year Program Plan (Apr. 2013) (“DOE 2013”). 89 pages.

Declaration of Colby Chevalier from Central District of California Civil Docket for Case #: 2:18-cv-07090-CAS-GJS filed Jun. 3, 2019, signed Jun. 3, 2019. 2 pages.

Docket Listing in Inter Partes Review of U.S. Pat. No. 9,964,266. Docket Navigator *AMP Plus, Inc. d/b/a Elco Lighting et al. v. DMF, Inc.* PTAB-IPR2019-01094. Downloaded Mar. 25, 2020. 4 pages.

Petition for Inter Partes Review of U.S. Pat. No. 9,964,266 Pursuant to 37 C.F.R. § 42.100 et seq. *AMP Plus Inc. dbd ELCO Lighting v. DMF, Inc.* PTAB-IPR2019-01500 filed Aug. 14, 2019. 99 pages.

Docket Listing in Inter Partes Review of U.S. Pat. No. 9,964,266 . *AMP Plus, Inc. d/b/a ELCO Lighting et al. v. DMF, Inc.* PTAB-IPR2019-01500. Downloaded Mar. 25, 2020. 3 pages.

Civil Action No. 2:18-cv-07090. Complaint For Infringement and Unfair Competition. *DMF, Inc. v. AMP Plus, Inc. d/b/a ELCO Lighting*. 52 pages. Dated Aug. 15, 2018.

Docket Listing in Civil Action No. 2:18-cv-07090. *DMF, Inc. v. AMP Plus, Inc. d/b/a ELCO Lighting et al.* CDCA-2-18-CV-07090. Downloaded on Mar. 25, 2020. 39 pages.

Civil Action No. 2:19-cv-4519. Complaint for Patent Infringement. *DMF, Inc. v. AMP Plus, Inc. d/b/a ELCO Lighting*. 52 pages dated May 22, 2019. 23 pages.

Docket Listing in Civil Action No. 2:19-cv-4519. *DMF Inc v. AMP Plus, Inc. d/b/a ELCO Lighting et al.* CDCA-2-19-cv-04519. Downloaded on Mar. 25, 2020. 3 pages.

Decision Denying Institution of Inter Partes Review of U.S. Pat. No. 9,964,266 in IPR2019-01500 dated Mar. 17, 2020. 21 pages.

Defendants’ Notice of Prior Art Pursuant to 35 U.S.C. § 282 in Civil Action No. 2:18-cv-07090-CAS-GJS dated Feb. 28, 2020. 7 pages.

Defendant AMP Plus, Inc.’s Opposition to DMF’s Motion for Summary Judgement in Civil Action No. 2:18-cv-07090-CAS-GJS filed Feb. 10, 2020. 32 pages.

Declaration of Eric Bretschneider, Ph.D in Support of Amp Plus, Inc.’s Opposition to Dmf, Inc.’s Motion for Partial Summary Judgment in Civil Action No. 2:18-cv-07090-CAS-GJS filed Feb. 10, 2020. 210 pages.

Plaintiff DMF’s Reply in Support of Motion for Partial Summary Judgment in Civil Action No. 2:18-cv-07090-CAS-GJS filed Feb. 18, 2020. 33 pages.

Declaration of James R. Benya in Support of Plaintiff DMF’s Motion for Summary Judgment in Civil Action No. 2:18-cv-07090-CAS-GJS filed Feb. 3, 2020. 193 pages.

Underwriters Laboratories Inc. Standard for Safely. UL 1598. Luminaires Jan. 11, 2020. 12 pages.

Exceptional LED Lighting Technology Product Portfolio. LightingScience 2012. 11 pages.

“Cree LMH2 LED Modules,” Mouser Electronics. Sep. 9, 2012. 4 pages.

Slim Line Disc. EYE LEDs Specification Sheet 2012. 2 pages.

HiBay LED Heat Sink. Wakefield-vette. Dec. 11, 2017. 1 pages.

Thermal Management of Cree® XLamp® LEDs. Cree Application Note. 2004. 19 pages.

Imtra Marine Lighting Fall 2007 Catalog. 32 pages.

Cree LMH2 LED Modules Product Family Data Sheet. Cree 2011-2014, 18 pages.

Cree LMH2 LED Modules Design Guide. Cree 2011-2015, 23 pages.

Brochure of Elco EL49A, EL49ICA, EL49RA modules. ELCO Lighting Nov. 25, 2009. 1 page.

Image of Elco E347/247 module identified by Elco in response to DMF’s Request for Production in Civil Action No. 2:18-cv-07090-CAS-GJS on Aug. 28, 2019. 1 page.

Screenshots from the Deposition of Brandon Cohen in Civil Action No. 2:18-cv-07090-CAS-GJS. Conducted Sep. 2, 2020. 8 pages.

Defendant AMP Plus, Inc.’s Initial Disclosure and Designation of Expert Witnesses in Civil Action No. 2:19-CV-4519-CAS. 37 pages.

Defendant AMP Plus, Inc. D/B/A Elco Lighting’s Supplemental Responses to Plaintiff DMF, Inc.’s First Set of Interrogatories (Nos. 1-16) in Civil Action No. 2:19-CV-4519-CAS, Redacted. 13 pages.

Final Written Decision in IPR2019-01094 dated Nov. 19, 2020, 58 pages.

Notice of Allowance dated Sep. 16, 2021 from U.S. Appl. No. 16/779,865, 9 pages.

Non-Final Office Action dated Oct. 18, 2021 1 from U.S. Appl. No. 29/696,830, 8 pages.

Canadian Office Action in Application No. 2941051 dated Dec. 8, 2020, 5 pages.

Final Office Action dated Jan. 11, 2021 from U.S. Appl. No. 15/688,266, 7 pages.

Non-Final Office Action dated Jan. 11, 2021 from U.S. Appl. No. 16/725,606, 7 pages.

Non-Final Office Action dated Jan. 13, 2021 from U.S. Appl. No. 17/085,636, 14 pages.

Notice of Allowance dated Jan. 15, 2021 from U.S. Appl. No. 17/000,702, 7 pages.

Notice of Allowance dated Jan. 22, 2021 from U.S. Appl. No. 17/080,080, 14 pages.

Notice of Allowance dated Jan. 22, 2021 from U.S. Appl. No. 16/886,365, 7 pages.

Final Office Action dated Feb. 5, 2021 from U.S. Appl. No. 16/200,393, 7 pages.

“Electrical Boxes” accessed at <http://electrical-inspector.blogspot.com/2013/06/electrical-boxes.html> Jun. 22, 2013 retrieved from Wayback MachineArchinve.org on Jan. 25, 2021. 12 pages.

“Electrical Boxes Volume and Fill Calculations” accessed at [http://electrical-inspector.blogspot.com/2013/06/electrical-boxes-Volume and-Fill-Calculations.html](http://electrical-inspector.blogspot.com/2013/06/electrical-boxes-Volume-and-Fill-Calculations.html) Jun. 22, 2013 retrieved from Wayback Machine Archinve.org on Jan. 25, 2021. 8 pages.

U.S. Appl. No. 61/881,162, filed Sep. 23, 2013. Priority application to US Publication No. 2015/0085500 to Cooper et al. 31 pages.

Non-Final Office Action dated Jan. 19, 2021 from U.S. Appl. No. 17/099,650, 15 pages.

Supplemental Notice of Allowance dated Mar. 10, 2021 from U.S. Appl. No. 16/886,365, 2 pages.

Notice of Allowance dated Apr. 6, 2021 from U.S. Appl. No. 16/200,393, 11 pages.

Non-Final Office Action dated Apr. 12, 2021 from U.S. Appl. No. 29/694,475, 11 pages.

Notice of Allowance dated Apr. 13, 2021 from U.S. Appl. No. 16/725,606, 7 pages.

Notice of Allowance dated Apr. 26, 2021 from U.S. Appl. No. 17/080,080, 11 pages.

Corrected Notice of Allowance dated Apr. 28, 2021 from U.S. Appl. No. 16/725,606, 2 pages.

Notice of Allowance dated May 5, 2021 from U.S. Appl. No. 17/085,636, 8 pages.

(56)

References Cited

OTHER PUBLICATIONS

Notice of Allowance dated May 14, 2021 from U.S. Appl. No. 16/881,686, 8 pages.
Notice of Allowance dated May 17, 2021 from U.S. Appl. No. 15/688,266, 9 pages.
Notice of Allowance dated May 24, 2021 from U.S. Appl. No. 29/688,143, 6 pages.
Notice of Allowance dated May 24, 2021 from U.S. Appl. No. 29/688,172, 6 pages.
Notice of Allowance dated May 27, 2021 from U.S. Appl. No. 16/779,865, 9 pages.
Notice of Allowance dated May 28, 2021 from U.S. Appl. No. 16/779,824, 11 pages.
Notice of Allowance dated Jun. 1, 2021 from U.S. Appl. No. 16/719,361, 7 pages.
Corrected Notice of Allowance dated Jun. 21, 2021 from U.S. Appl. No. 16/779,865, 3 pages.
Non-Final Office Action dated Jul. 14, 2021 from U.S. Appl. No. 17/118,742, 11 pages.
Notice of Allowance dated Jul. 21, 2021 from U.S. Appl. No. 17/318,13 pages.
Supplemental Notice of Allowance dated Aug. 13, 2021 1 from U.S. Appl. No. 16/779,824, 3 pages.
Supplemental Notice of Allowance dated Aug. 19, 2021 1 from U.S. Appl. No. 17/318,193, 4 pages.

* cited by examiner

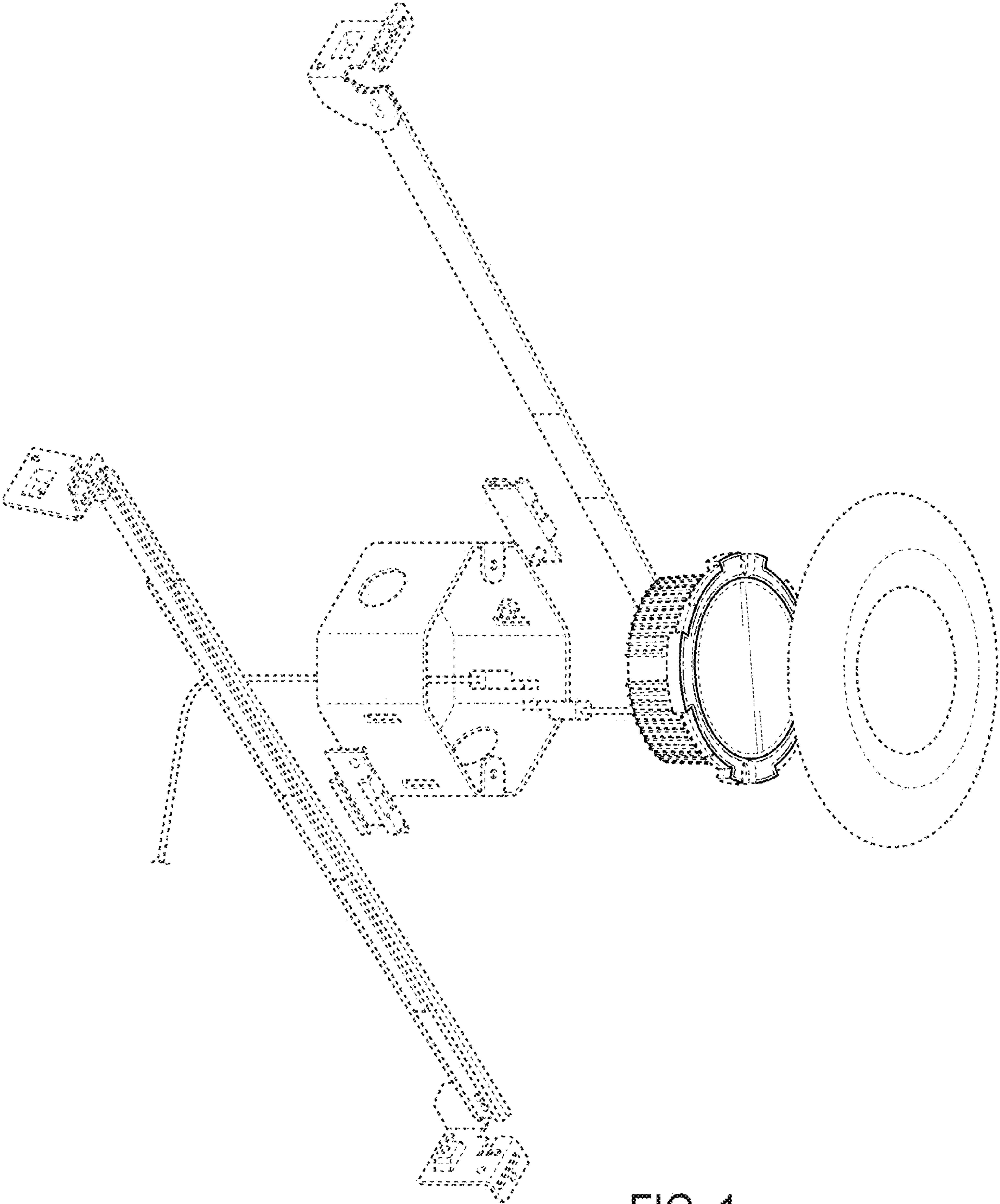

FIG. 1

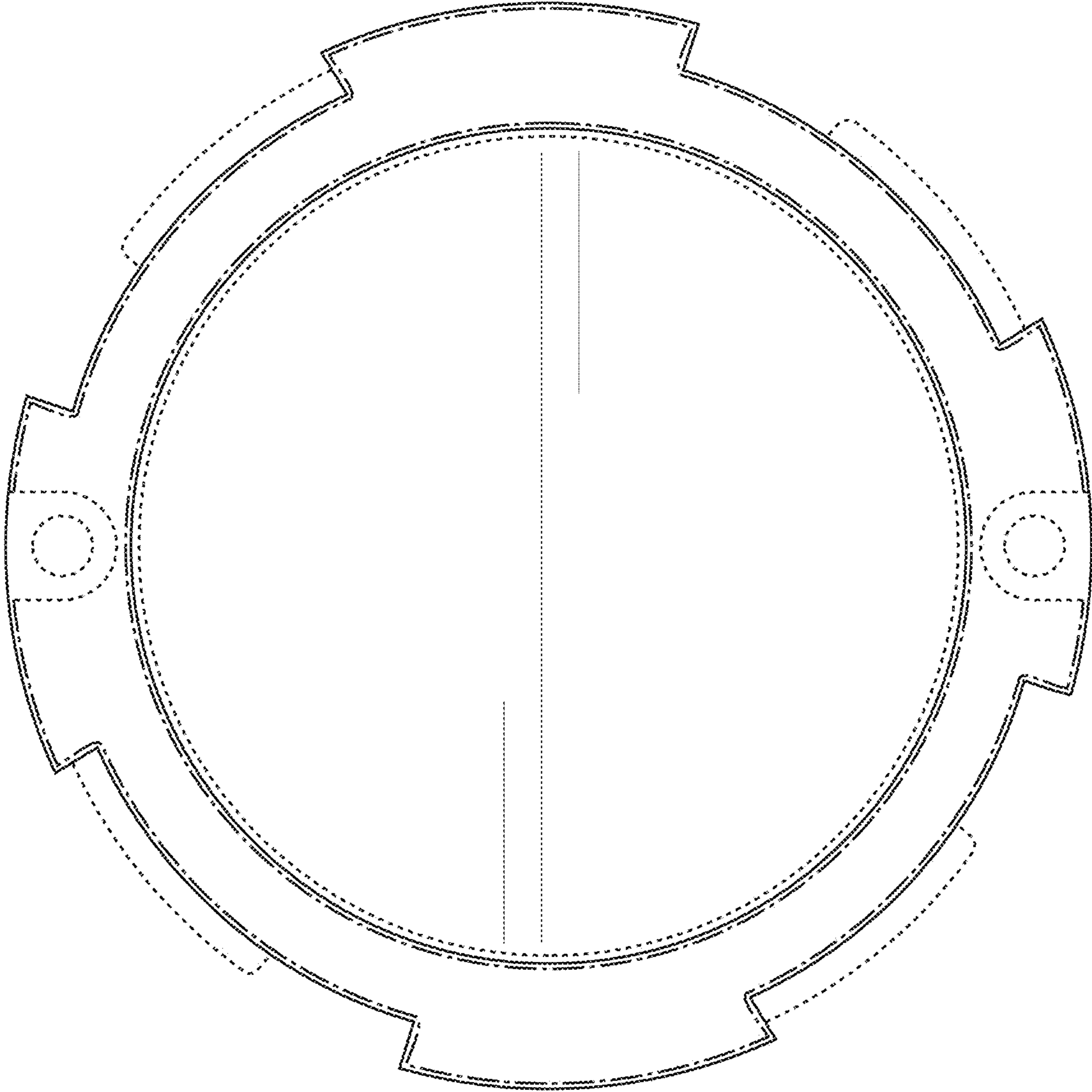

FIG. 2