



US00D938871S

(12) **United States Design Patent**  
**Kim**

(10) **Patent No.:** **US D938,871 S**

(45) **Date of Patent:** **\*\* Dec. 21, 2021**

(54) **DISC BRAKE CALIPER FOR VEHICLE**

(71) Applicant: **MANDO CORPORATION,**  
Gyeonggi-do (KR)

(72) Inventor: **Hong Ki Kim,** Gyeonggi-do (KR)

(73) Assignee: **MANDO CORPORATION,**  
Gyeonggi-Do (KR)

(\*\*) Term: **15 Years**

(21) Appl. No.: **29/714,055**

(22) Filed: **Nov. 20, 2019**

(30) **Foreign Application Priority Data**

Nov. 1, 2019 (KR) ..... 30-2019-0052057

(51) **LOC (13) Cl.** ..... **12-16**

(52) **U.S. Cl.**  
USPC ..... **D12/180**

(58) **Field of Classification Search**

USPC ..... D12/123, 160, 179, 180  
CPC ..... F16D 55/22; F16D 55/225; F16D 55/226;  
F16D 55/227; F16D 55/228; F16D  
65/0068; F16D 65/18; F16D 65/183;  
F16D 65/58; F16D 65/092; F16D 65/12;  
F16D 65/068; F16D 65/0975; F16D  
2055/0016; B60T 1/065; B60T 13/588

See application file for complete search history.

(56) **References Cited**

**U.S. PATENT DOCUMENTS**

D520,924 S \* 5/2006 Gotti ..... D12/180  
D790,417 S \* 6/2017 Bertone ..... D12/180  
D813,125 S \* 3/2018 Crippa ..... D12/180  
D831,551 S \* 10/2018 Wilson ..... D12/190  
D837,704 S \* 1/2019 Huang ..... D12/180  
D840,301 S \* 2/2019 Bonetti ..... D12/180  
D862,327 S \* 10/2019 Scotti ..... D12/180

D892,007 S \* 8/2020 Scotti ..... D12/180  
2008/0029356 A1 \* 2/2008 Halasy-Wimmer .....  
F16D 55/227  
188/73.45  
2013/0092481 A1 \* 4/2013 Crippa ..... F16D 55/228  
188/73.31  
2014/0158483 A1 \* 6/2014 Miyahara ..... F16D 65/0068  
188/73.47  
2015/0027821 A1 \* 1/2015 Nessi ..... F16D 65/0975  
188/72.3  
2018/0031060 A1 \* 2/2018 Huang ..... B60T 13/588

\* cited by examiner

*Primary Examiner* — Susan E Krakower

*Assistant Examiner* — Jerry Shiuan-Hua Hsu

(74) *Attorney, Agent, or Firm* — Ladas & Parry, LLP

(57) **CLAIM**

The ornamental design for a disc brake caliper for vehicle,  
as shown and described.

**DESCRIPTION**

FIG. 1 is a front, top, left-side perspective view of a disc  
brake caliper for vehicle showing the claimed design;  
FIG. 2 is a front view thereof;  
FIG. 3 is a rear view thereof;  
FIG. 4 is a left-side view thereof;  
FIG. 5 is a right-side view thereof;  
FIG. 6 is a top view thereof;  
FIG. 7 is a bottom view thereof;  
FIG. 8 is a bottom, front, right-side perspective view thereof;  
and,  
FIG. 9 is a front, top left-side perspective view thereof,  
shown in a state of use.

The broken lines within the claimed design illustrate por-  
tions of the disc brake caliper for vehicle, which form no part  
of the claimed design. The broken lines depicting a disc  
brake in FIG. 9 shows environmental structure which forms  
no part of the claimed design.

**1 Claim, 6 Drawing Sheets**

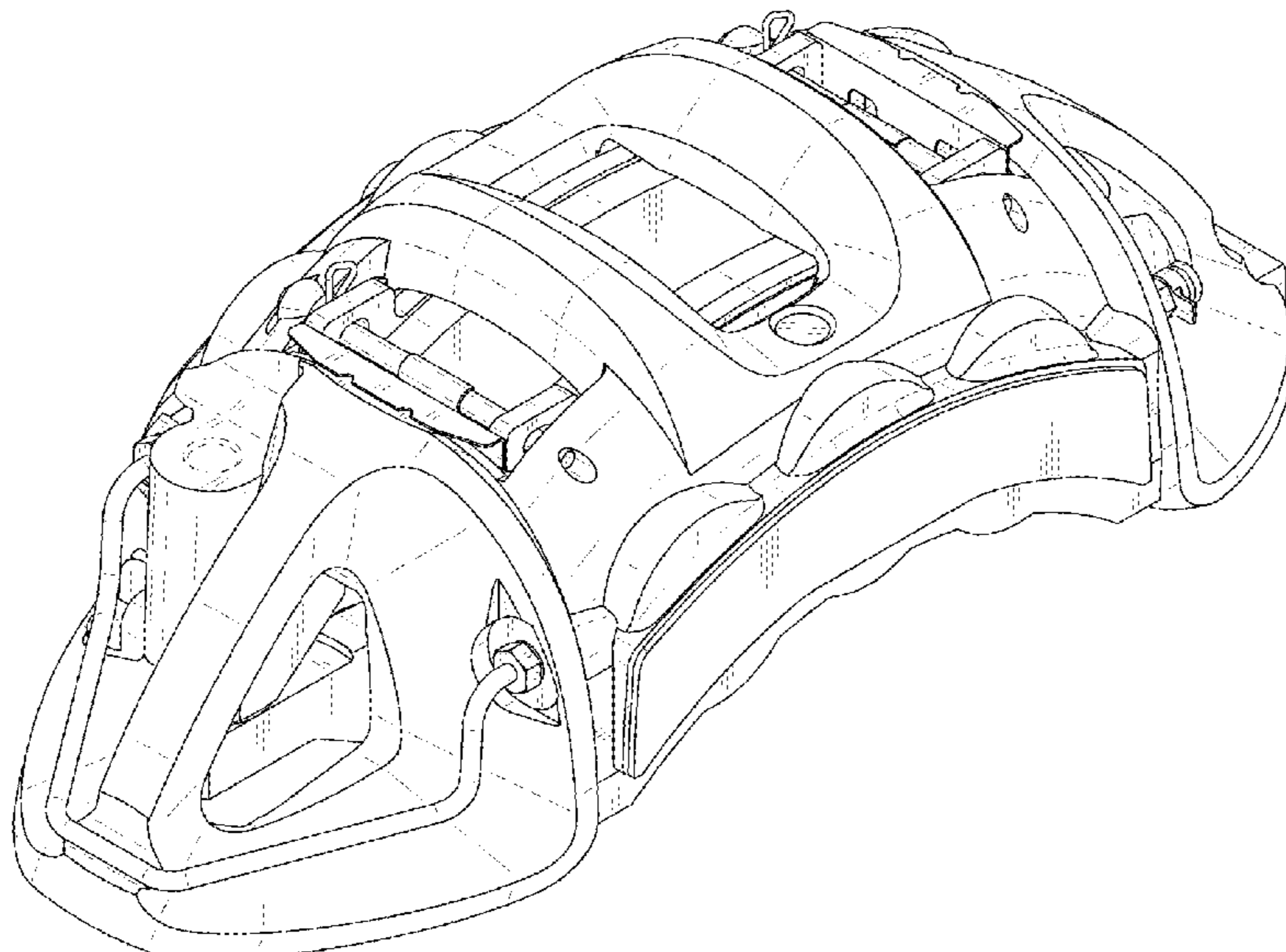

FIG. 1

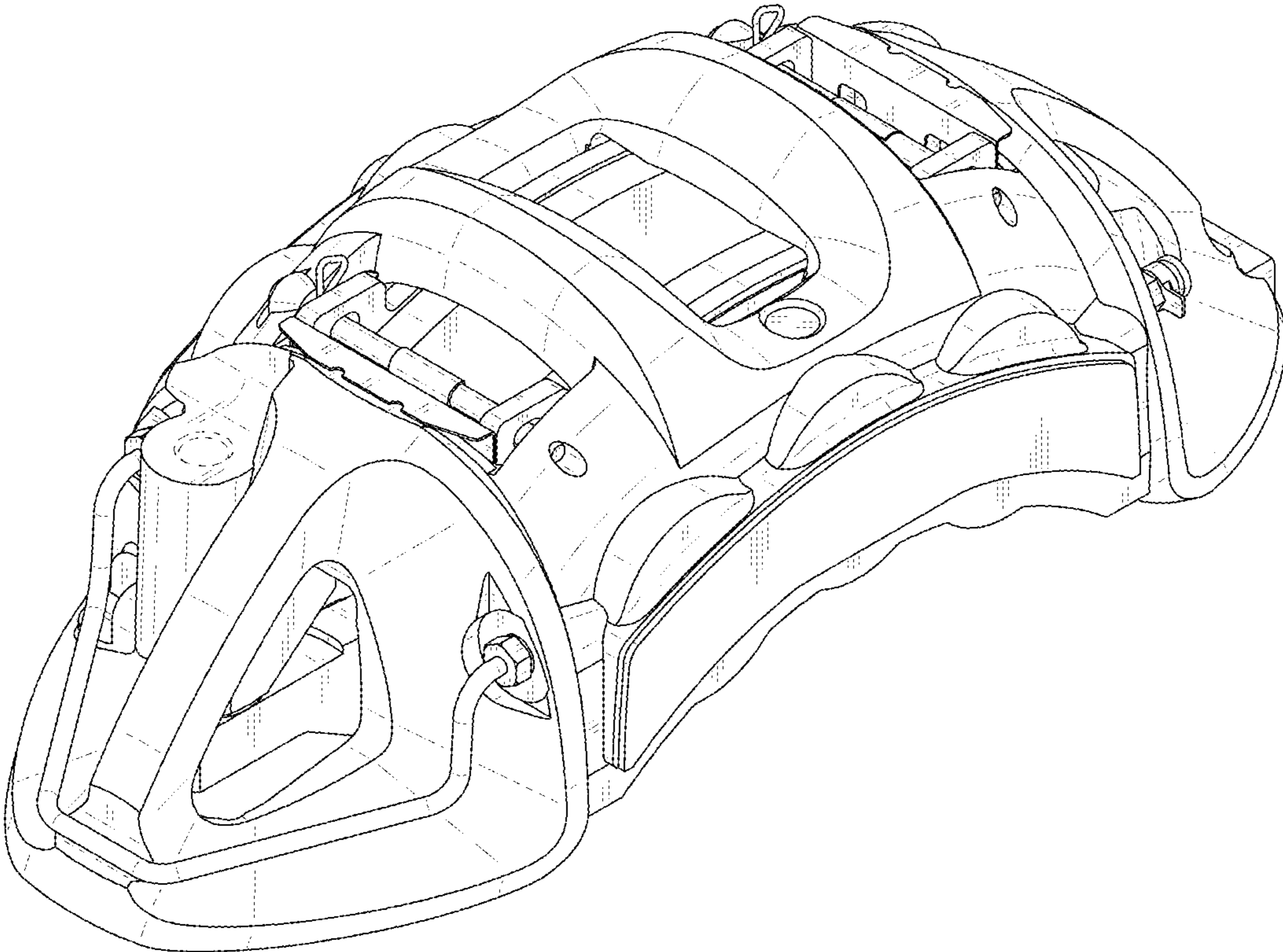

FIG. 2

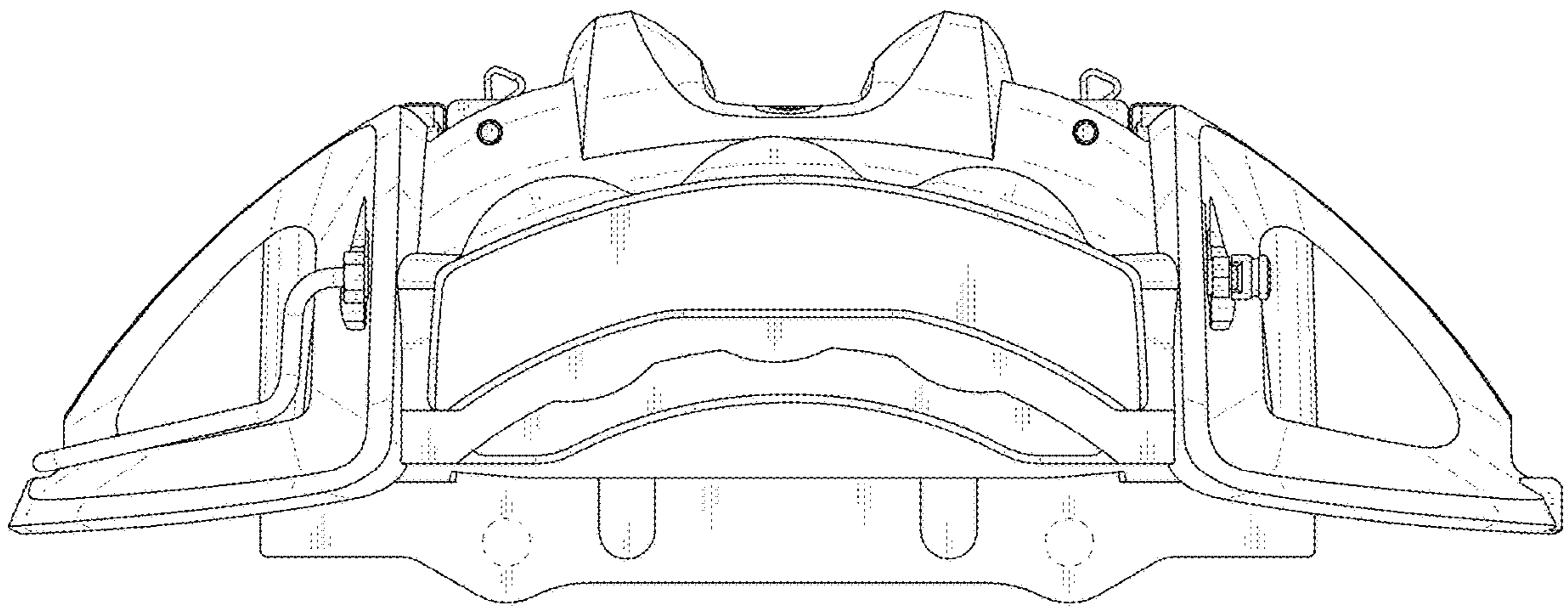

FIG. 3

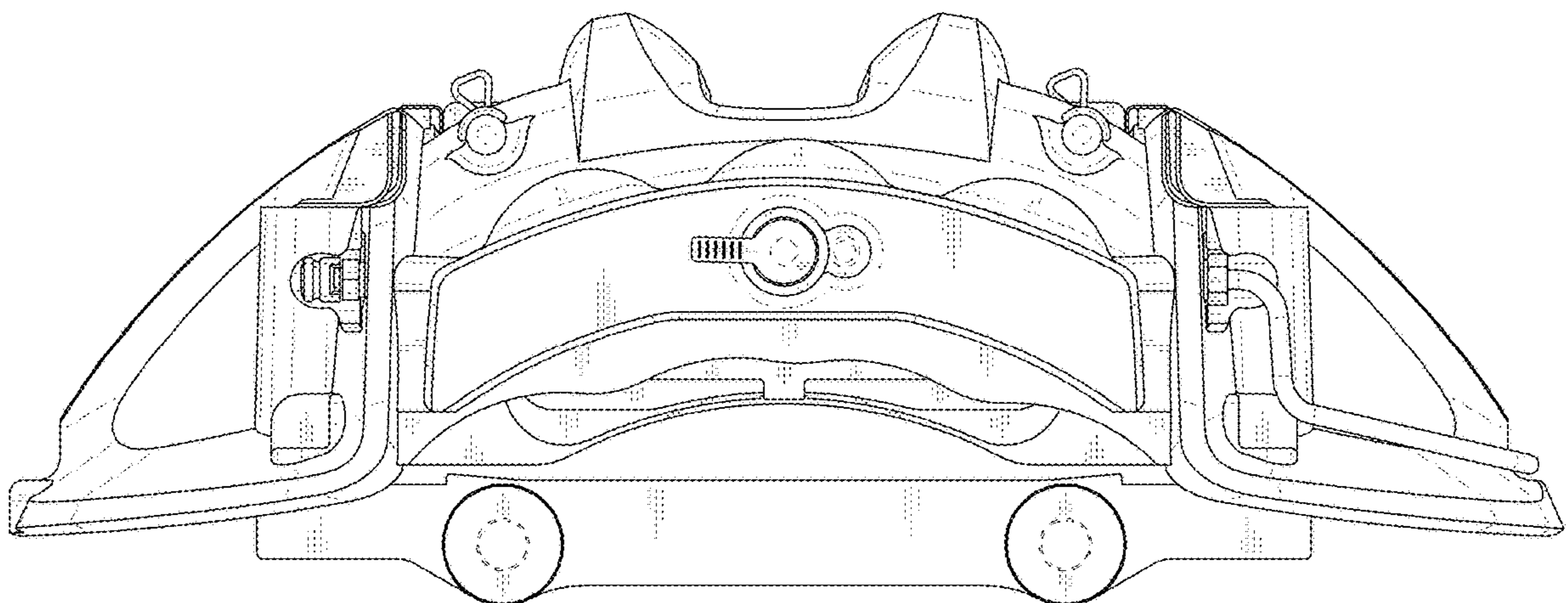

FIG. 4

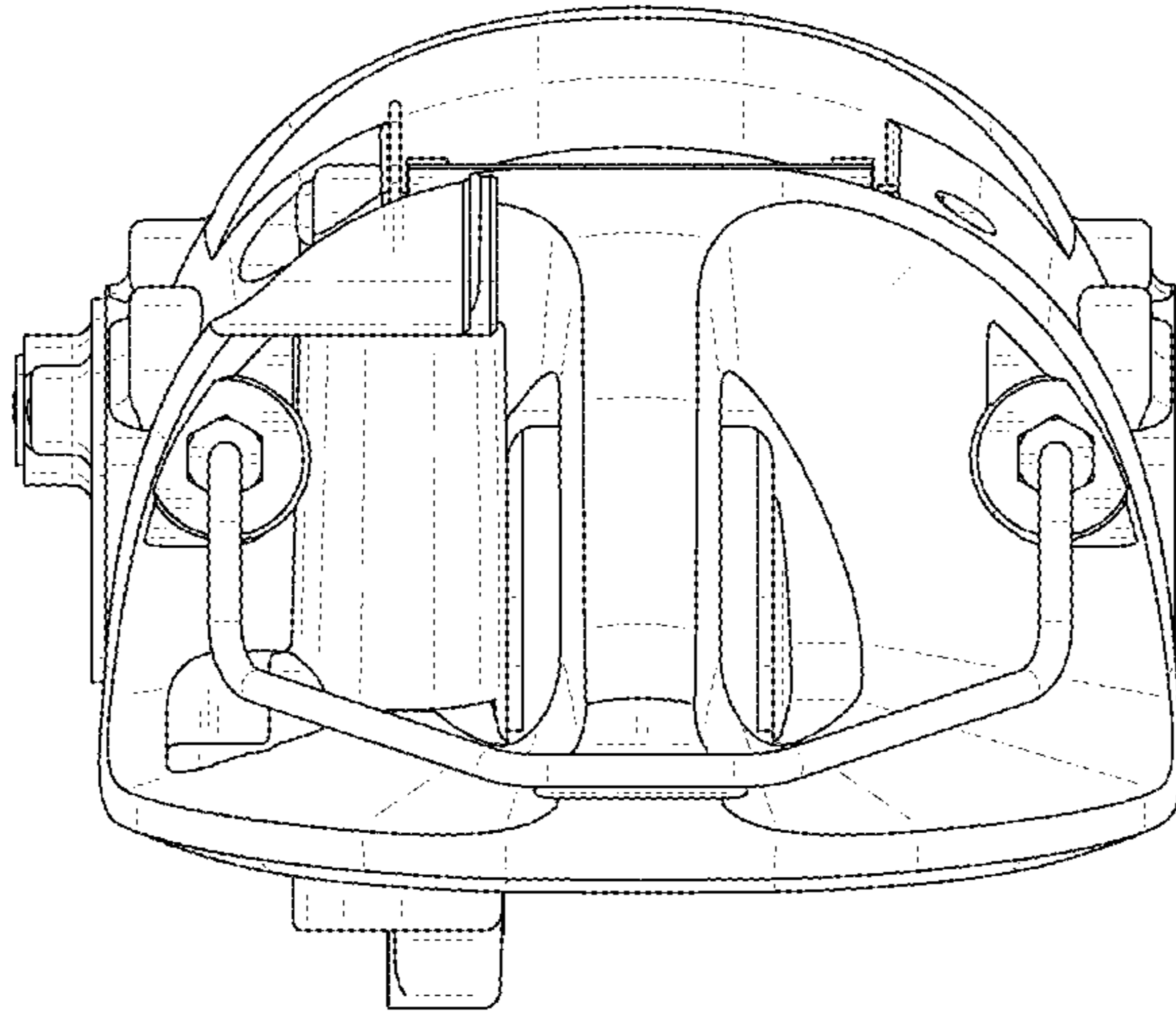

FIG. 5

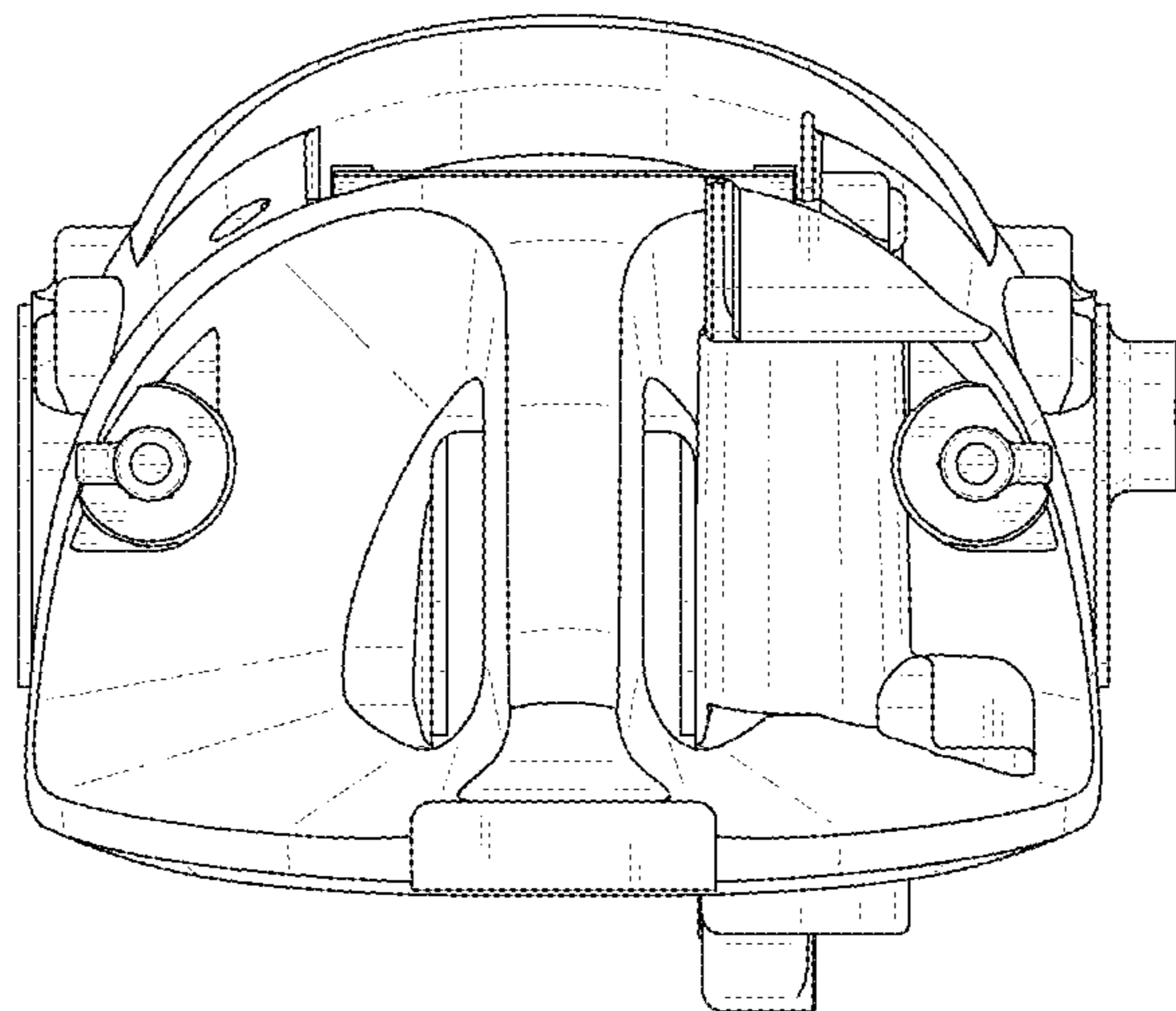

FIG. 6

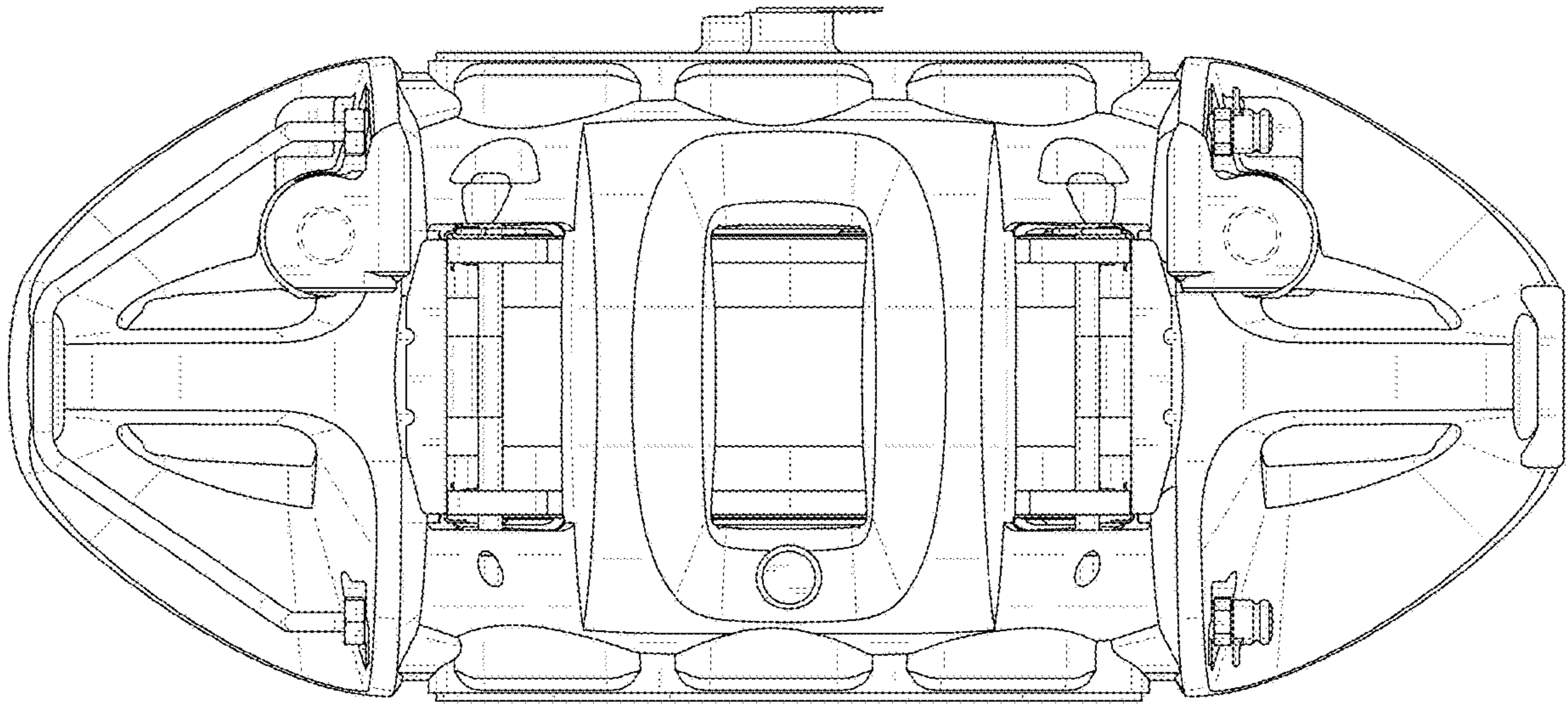

FIG. 7

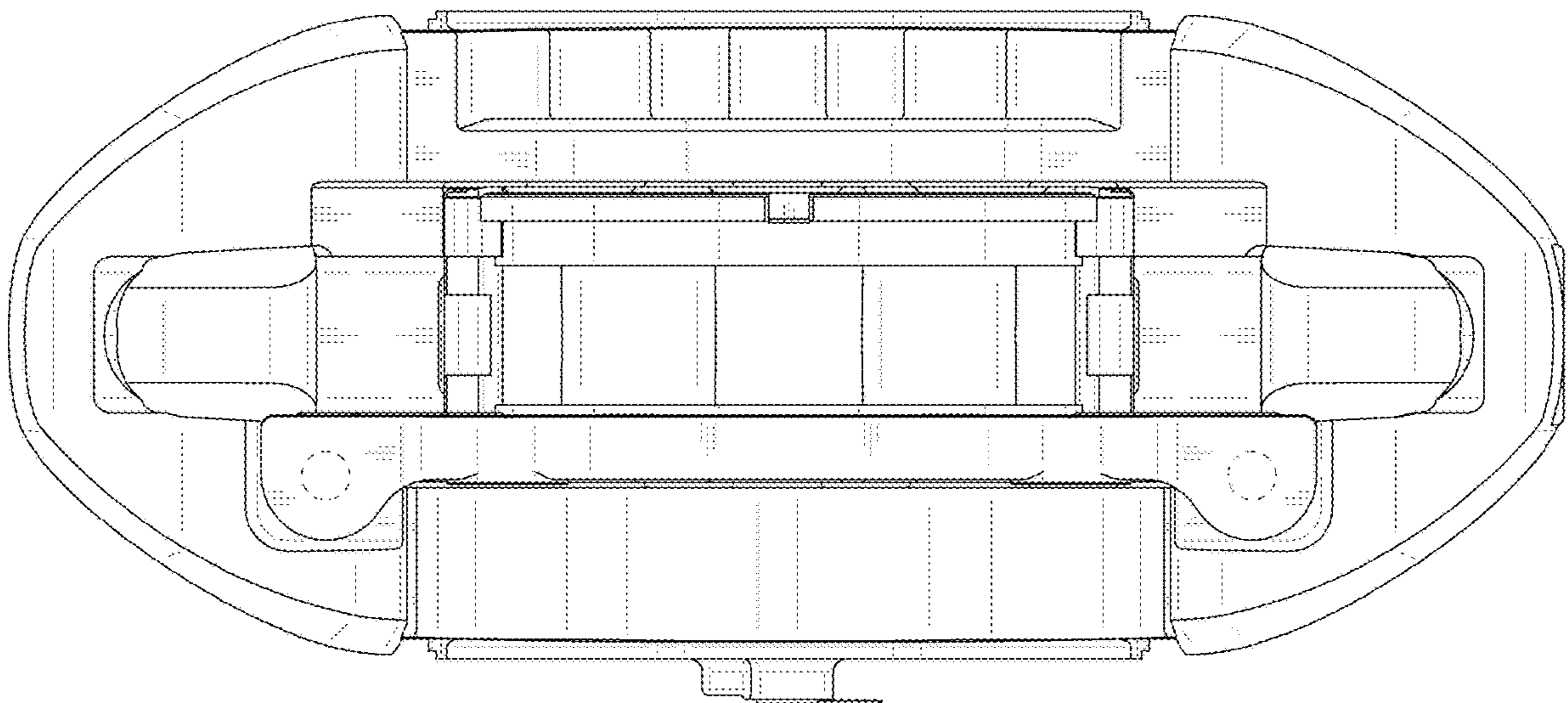

FIG. 8

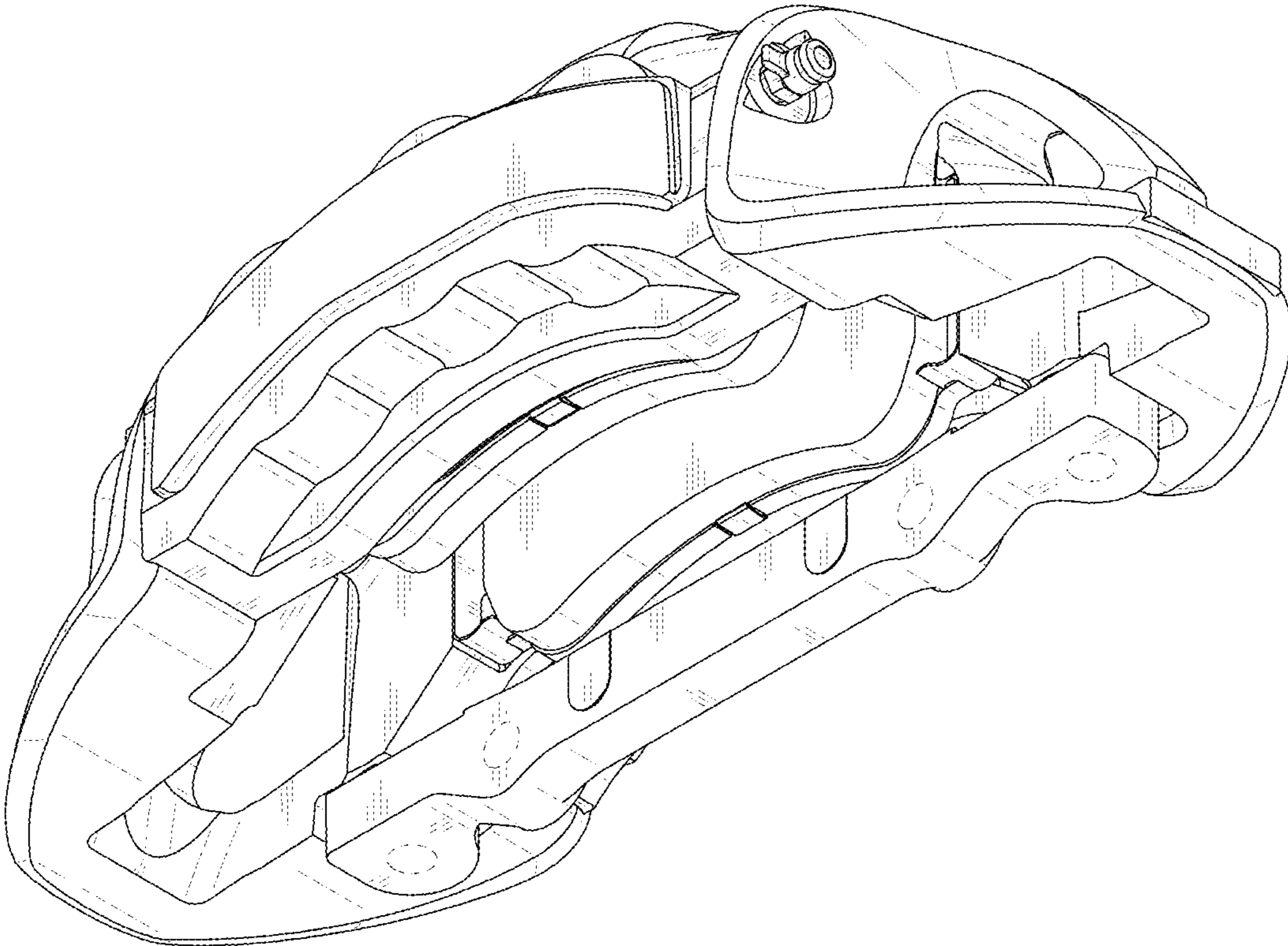

FIG. 9

