



US00D938767S

(12) **United States Design Patent**
Palma

(10) **Patent No.:** **US D938,767 S**

(45) **Date of Patent:** **** Dec. 21, 2021**

(54) **BACK AND SEAT FOR A CHAIR**

(71) Applicant: **Alberto Palma**, Costa Mesa, CA (US)

(72) Inventor: **Alberto Palma**, Costa Mesa, CA (US)

(**) Term: **15 Years**

(21) Appl. No.: **29/740,050**

(22) Filed: **Jun. 30, 2020**

(51) **LOC (13) Cl.** **06-01**

(52) **U.S. Cl.**
USPC **D6/716**

(58) **Field of Classification Search**
USPC D6/334, 364, 365, 366, 370, 371, 373,
D6/374, 379, 380, 716.1, 716.4, 716
CPC A47C 3/00; A47C 3/04; A47C 3/12; A47C
3/18; A47C 3/20; A47C 1/143; A47C
1/12; A47C 1/121; A47C 1/124; A47C
7/24; A47C 7/36; A47C 7/46; A47C 7/18;
A47C 7/40; A47C 7/54

See application file for complete search history.

(56) **References Cited**

U.S. PATENT DOCUMENTS

D467,442 S *	12/2002	Zaidman	D6/366
D532,225 S *	11/2006	Egger	D6/716
D566,435 S *	4/2008	Grove	D6/366
9,033,411 B2 *	5/2015	Mezzera	A47C 7/38 297/123
D769,633 S *	10/2016	Mezzera	D6/366
D769,634 S *	10/2016	Mezzera	D6/366

D770,820 S *	11/2016	Mezzera	D6/716
D809,841 S *	2/2018	Mao	D6/716
D811,793 S *	3/2018	Palma	D6/716
D879,492 S *	3/2020	Wang	D6/366
D902,615 S *	11/2020	Palma	D6/366
D918,611 S *	5/2021	Wang	D6/366
2006/0097556 A1 *	5/2006	Jang	A47C 7/46 297/284.4

* cited by examiner

Primary Examiner — R. Johnson

(74) *Attorney, Agent, or Firm* — Morland C. Fischer

(57) **CLAIM**

The ornamental design for a back and seat for a chair, as shown and described.

DESCRIPTION

FIG. 1 is a top, right, front perspective view of a back and seat for a chair showing my new design; FIG. 2 is a top, left, rear perspective view thereof; FIG. 3 is a front elevational view thereof; FIG. 4 is a right side elevational view thereof; FIG. 5 is a rear elevational view thereof; FIG. 6 is a left side elevational view thereof; FIG. 7 is a top plan view thereof; and, FIG. 8 is a bottom plan view thereof.

The long broken lines in the figures indicate environment that forms no part of the claimed design. The short broken lines in the figures represent stitching.

The short broken lines in the figures are understood to represent stitching.

1 Claim, 7 Drawing Sheets





FIG. 1

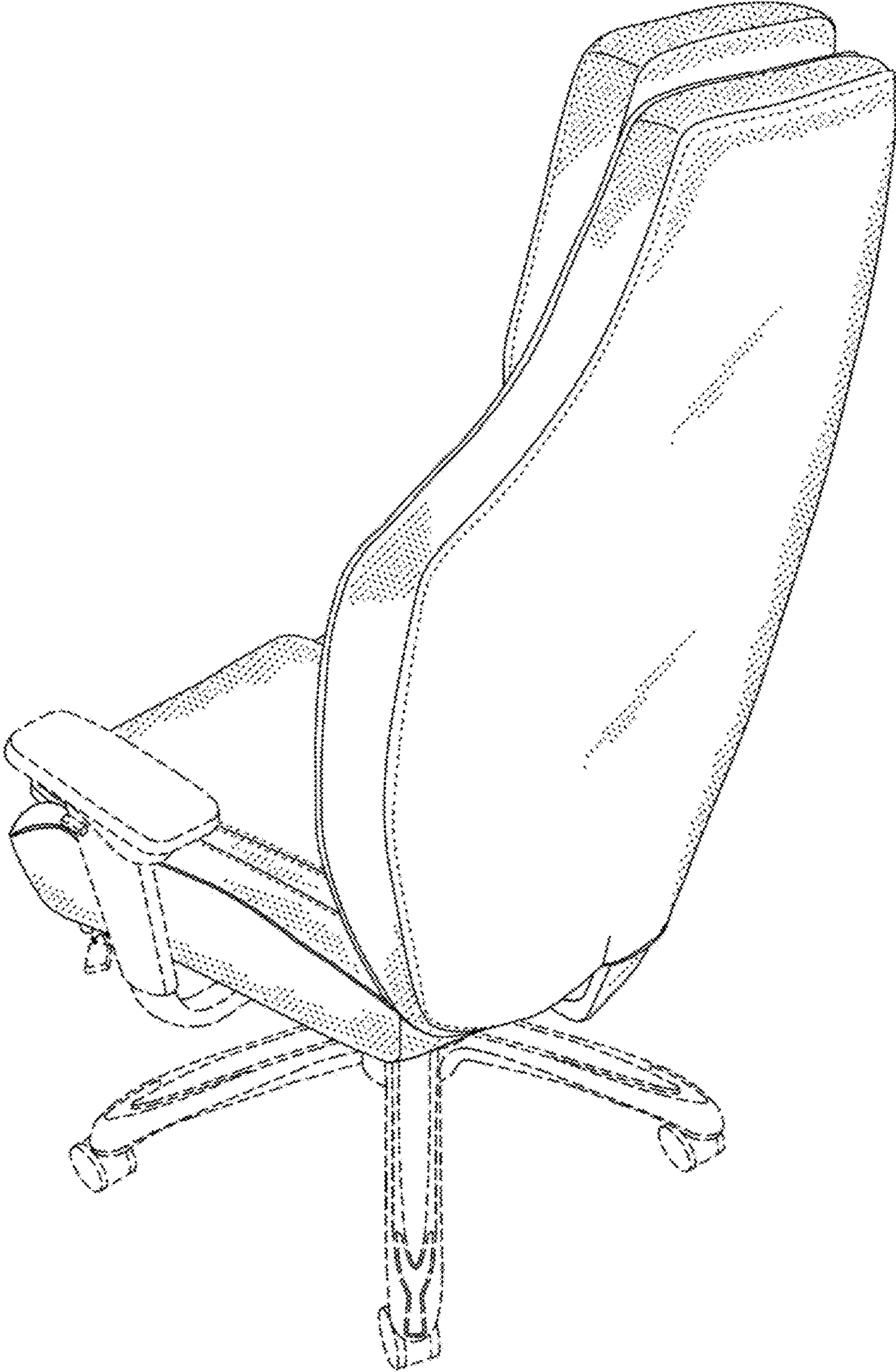

FIG. 2

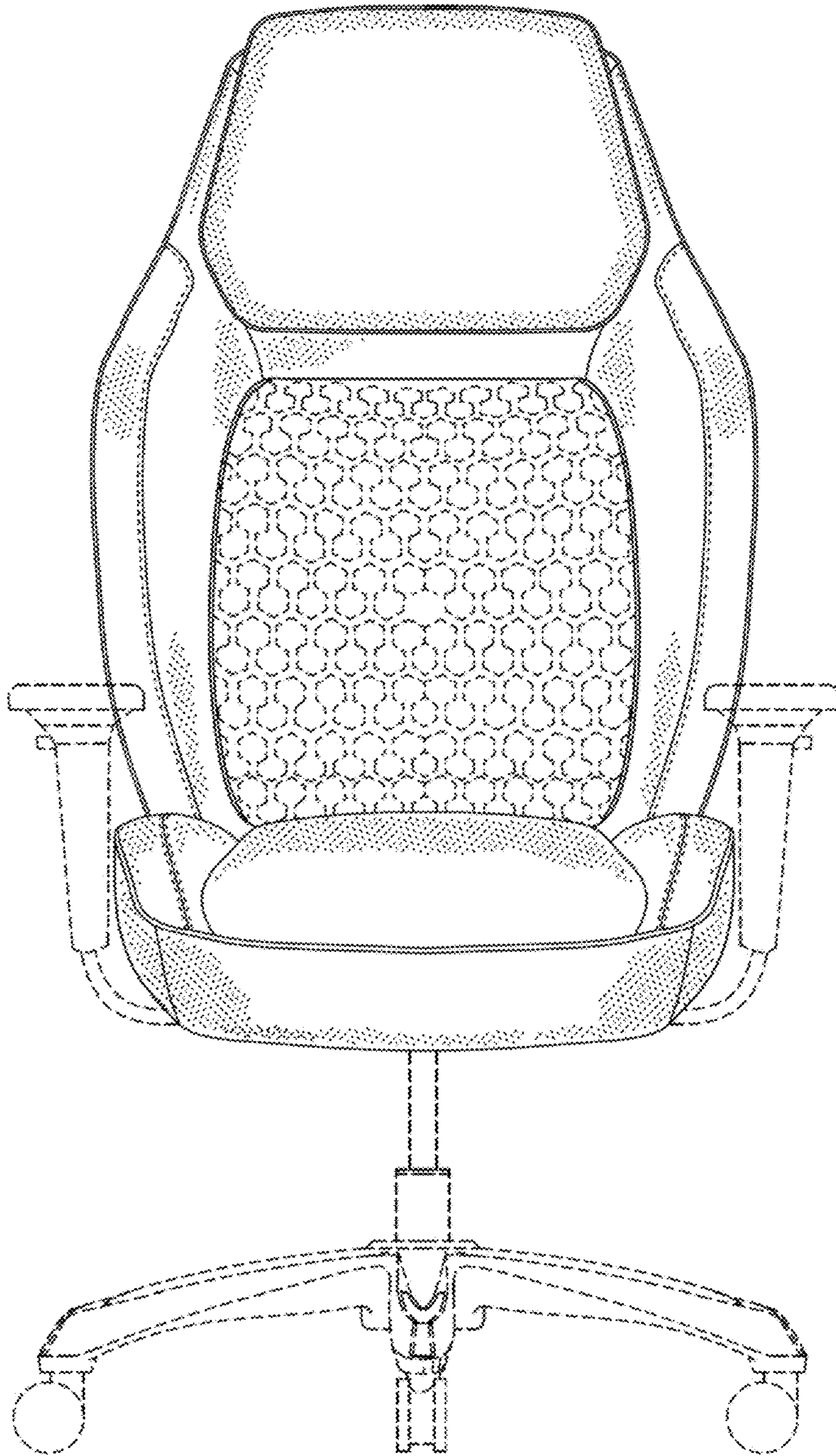

FIG. 3

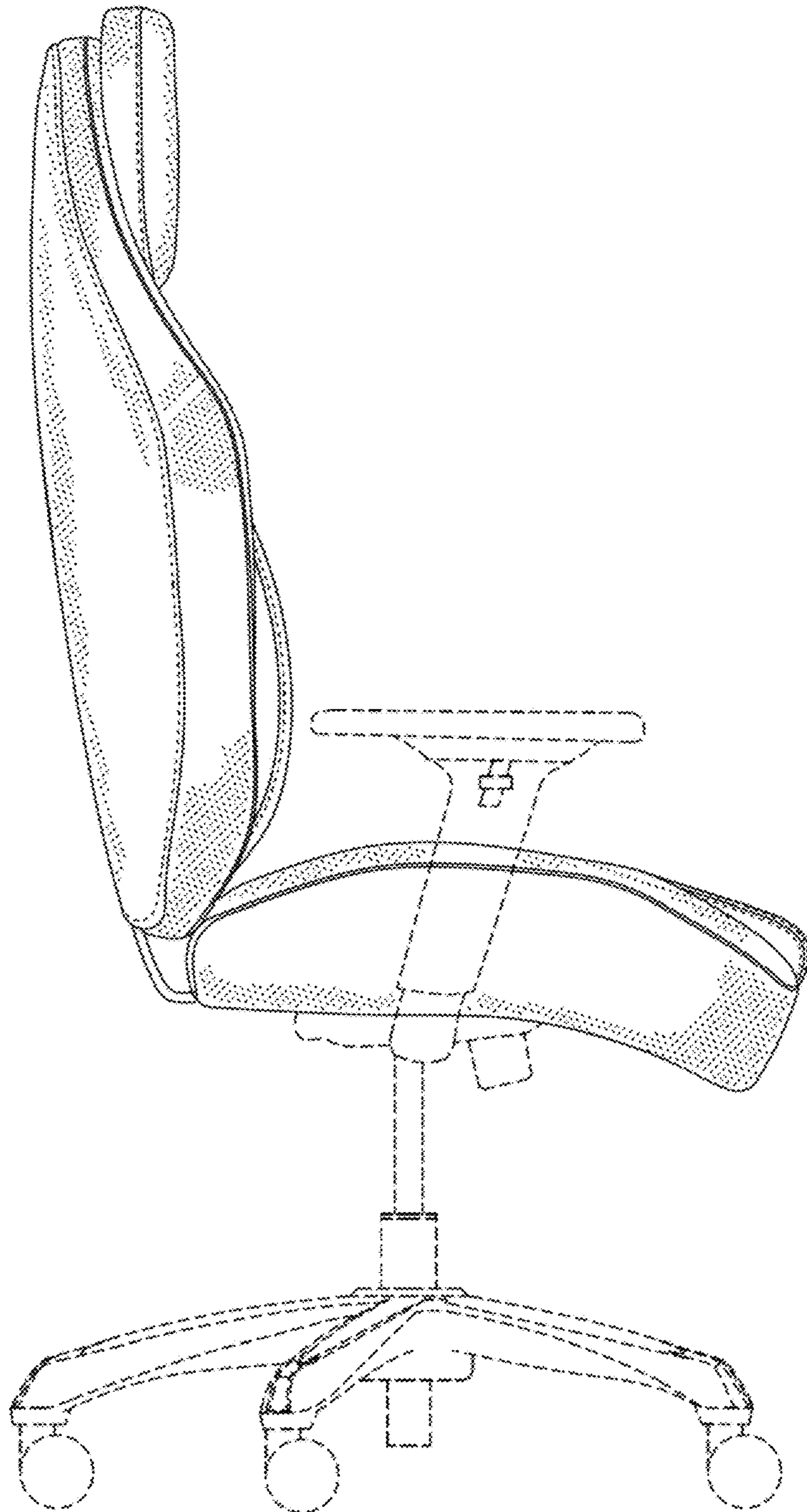

FIG. 4

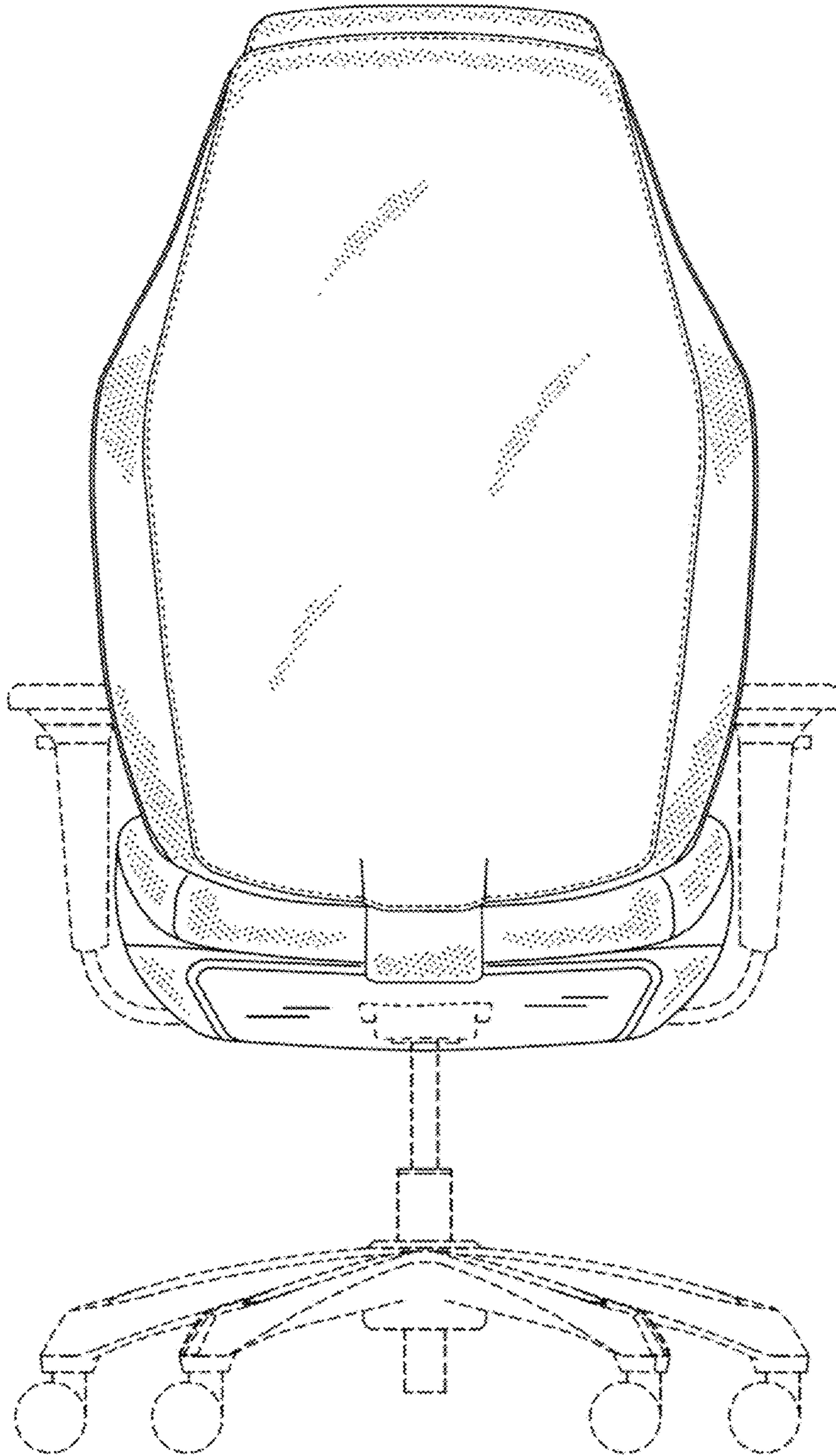

FIG. 5

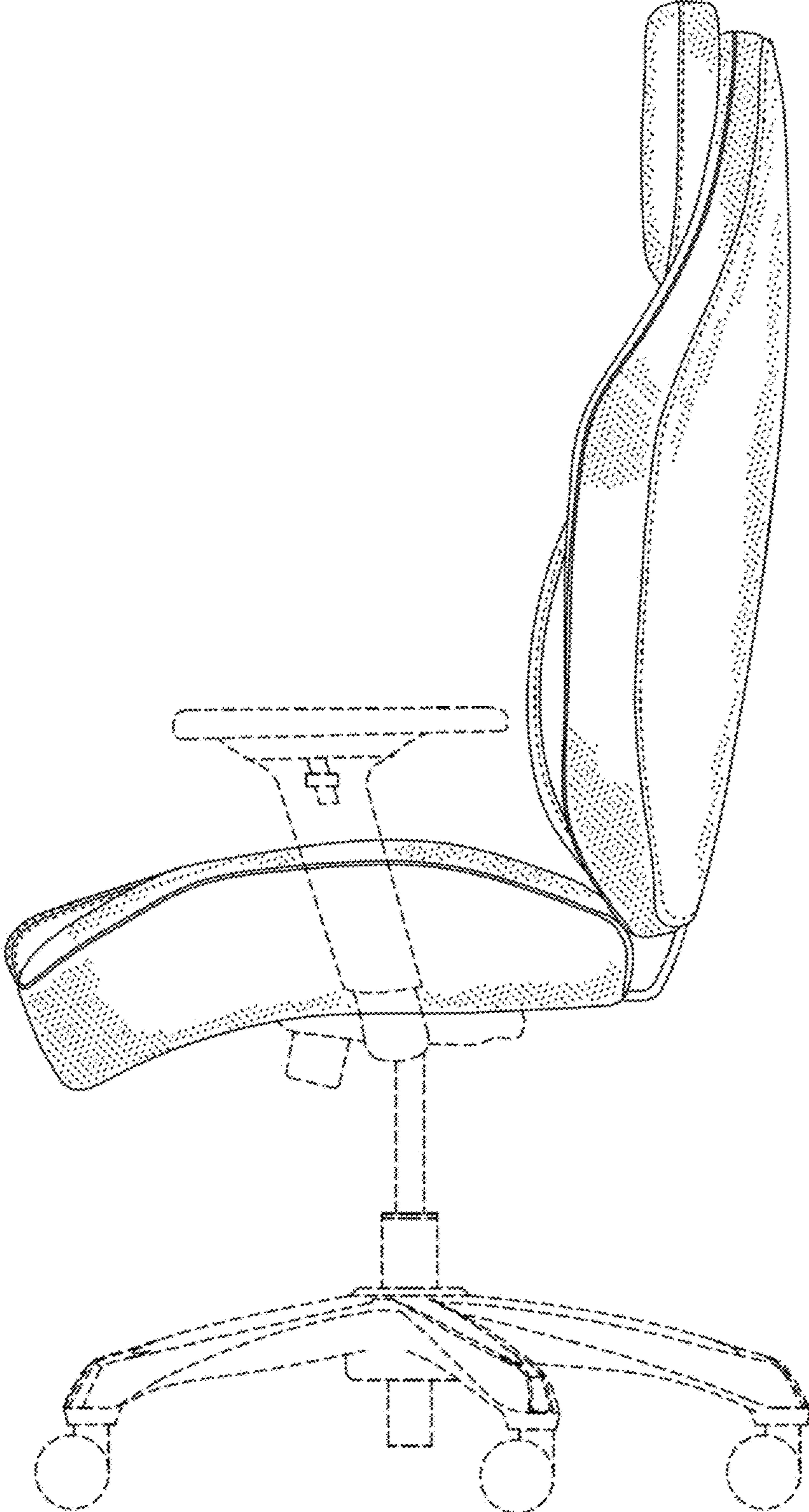

FIG. 6

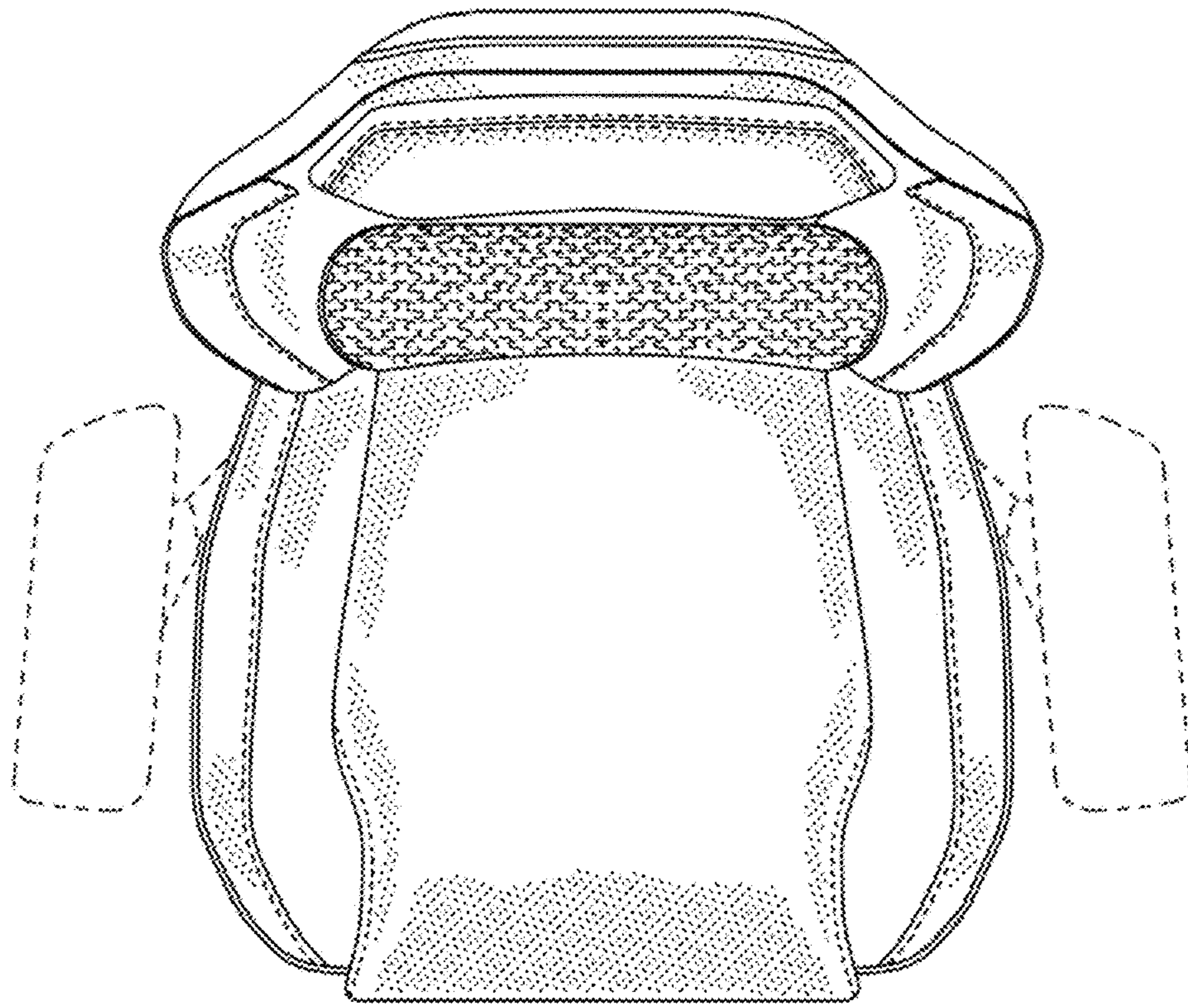

FIG. 7

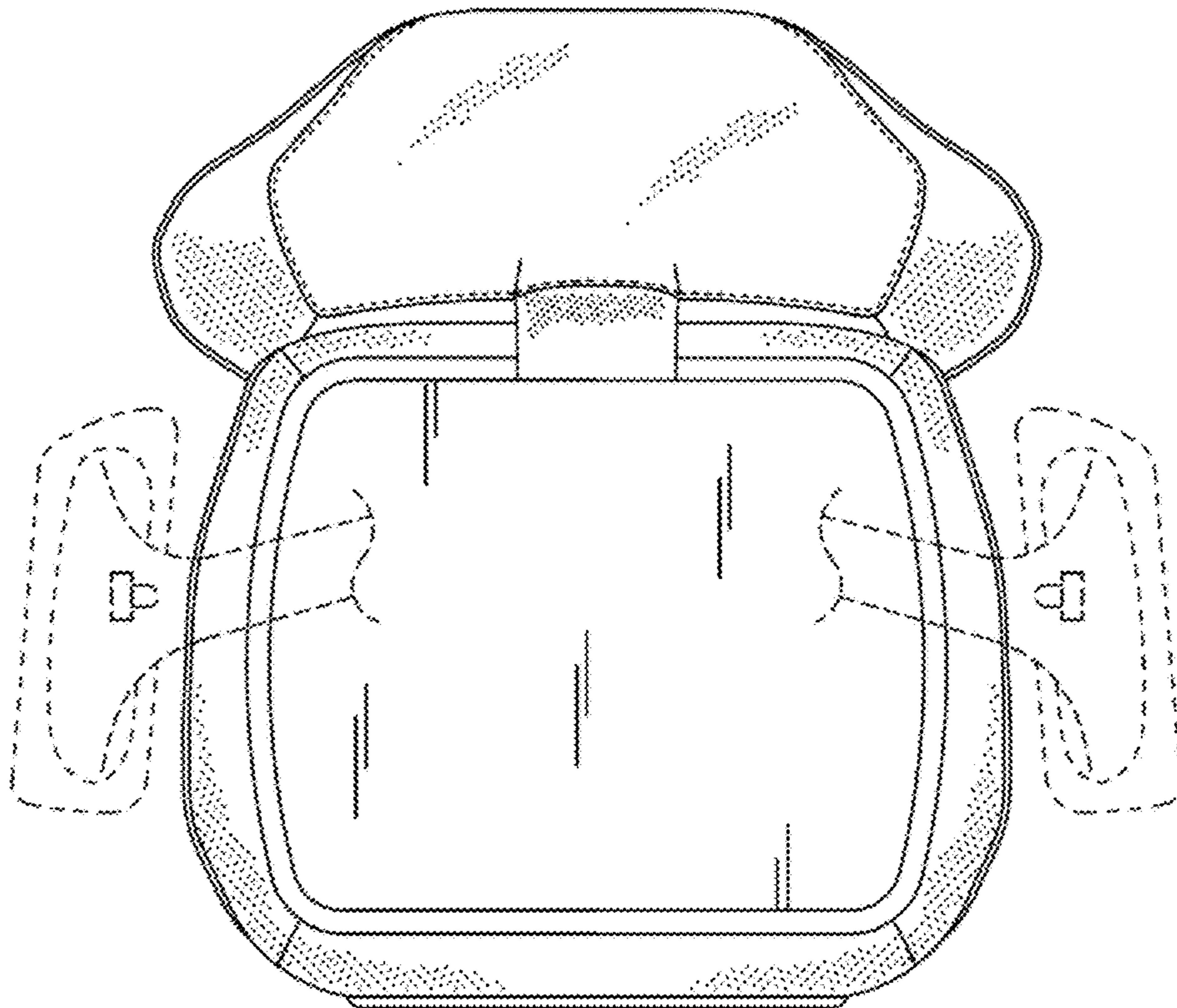

FIG. 8