



US00D937791S

(12) **United States Design Patent**
Jeong et al.

(10) **Patent No.:** **US D937,791 S**

(45) **Date of Patent:** **** Dec. 7, 2021**

(54) **FLEXIBLE PRINTED CIRCUIT BOARD FOR BATTERY MODULE**

D740,769 S * 10/2015 Takagi D13/182
9,713,251 B2 * 7/2017 Kato H05K 1/0298
D805,044 S * 12/2017 Sakai D13/182
10,056,669 B2 * 8/2018 Baba H01P 3/18

(Continued)

(71) Applicant: **LG Chem, Ltd.**, Seoul (KR)

(72) Inventors: **Jong-Ha Jeong**, Daejeon (KR);
Jung-Min Kwak, Daejeon (KR);
Do-Hyun Park, Daejeon (KR);
Jun-Yeob Seong, Daejeon (KR);
Young-Ho Lee, Daejeon (KR)

(73) Assignee: **LG Chem, Ltd.**

(**) Term: **15 Years**

(21) Appl. No.: **29/696,210**

(22) Filed: **Jun. 26, 2019**

(30) **Foreign Application Priority Data**

Dec. 26, 2018 (KR) 30-2018-0061684

(51) **LOC (13) Cl.** **13-03**

(52) **U.S. Cl.**
USPC **D13/182**

(58) **Field of Classification Search**
USPC D24/168, 187; D10/52, 81; D11/3;
D13/182

CPC H05K 1/028; H05K 1/118; H05K 1/0221;
H05K 1/0237; H05K 1/0242; H05K
1/025; H05K 1/0266; H05K 1/0271;
H05K 1/0393; H05K 1/111; H05K 1/14;
H05K 1/189; H05K 2201/09327; H05K
2201/09618; H05K 2201/09663; H05K
2201/09909

See application file for complete search history.

(56) **References Cited**

U.S. PATENT DOCUMENTS

6,227,870 B1 * 5/2001 Tanaka H01R 13/2435
439/66
8,342,384 B2 * 1/2013 Schulz-Harder C04B 37/021
228/122.1

OTHER PUBLICATIONS

Flexible Circuit Boards. (Design—© Questel) orbit.com. [Online PDF compilation of references selected by examiner] 108 pgs. Print Dates Range Sep. 27, 2019-Mar. 12, 2010 [Retrieved Jul. 13, 2021].*

(Continued)

Primary Examiner — Manpreet S Matharu

Assistant Examiner — Suzanne E Tisdell

(74) *Attorney, Agent, or Firm* — Lerner, David,
Littenberg, Krumholz & Mentlik, LLP

(57) **CLAIM**

The ornamental design for a flexible printed circuit board for battery module, as shown and described.

DESCRIPTION

FIG. 1 is a front perspective view of a flexible printed circuit board for battery module according to our design;
FIG. 2 is a front view thereof;
FIG. 3 is a rear view thereof;
FIG. 4 is a left side view thereof;
FIG. 5 is a right side view thereof;
FIG. 6 is a top view thereof;
FIG. 7 is a bottom view thereof; and,
FIG. 8 is a rear perspective view thereof.

The flexible printed circuit board (FPCB) for a battery module of this design is made of metal and synthetic resin. The flexible printed circuit board (FPCB) for a battery module of this design is mainly used in an electric vehicle. Color forms no part of the claimed design.

1 Claim, 5 Drawing Sheets

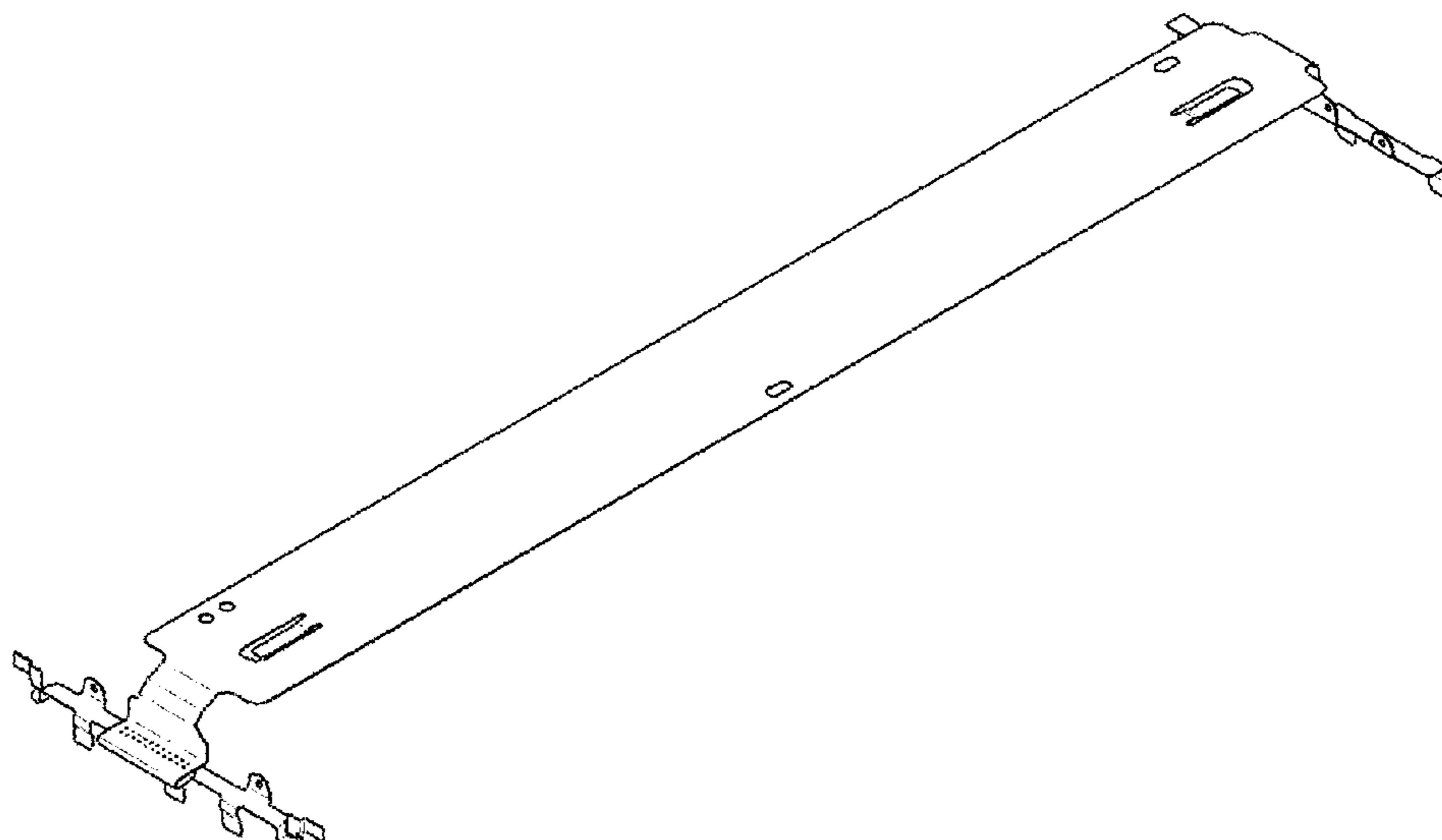

(56)

References Cited

U.S. PATENT DOCUMENTS

D877,102 S * 3/2020 Kamiyama D13/182
D886,073 S * 6/2020 Kim D13/182
D887,998 S * 6/2020 Krasnopolski D13/182
D903,613 S * 12/2020 Furutani D13/182
10,893,615 B2 * 1/2021 Rietsch H05K 3/366
D913,978 S * 3/2021 Furutani D13/182
D920,935 S * 6/2021 Sambu D13/182

OTHER PUBLICATIONS

“Integrated USB 3.1 Connector Supports Mobile Platforms.” Dec. 7, 2015. Thomas. <https://news.thomasnet.com/fullstory/integrated-usb-3-1-connector-supports-mobile-platforms-20051860>.*

Provancher, William R. “Flex—Circuit Soldering & Assembly Tutorial and Notes.” Aug. 27, 2004. University of Utah. https://my.mech.utah.edu/~wil/tutorials/flexCirc_soldering_tutorial/Flex_circuit_Soldering_Tutorial.html.*

* cited by examiner

【FIG. 1】

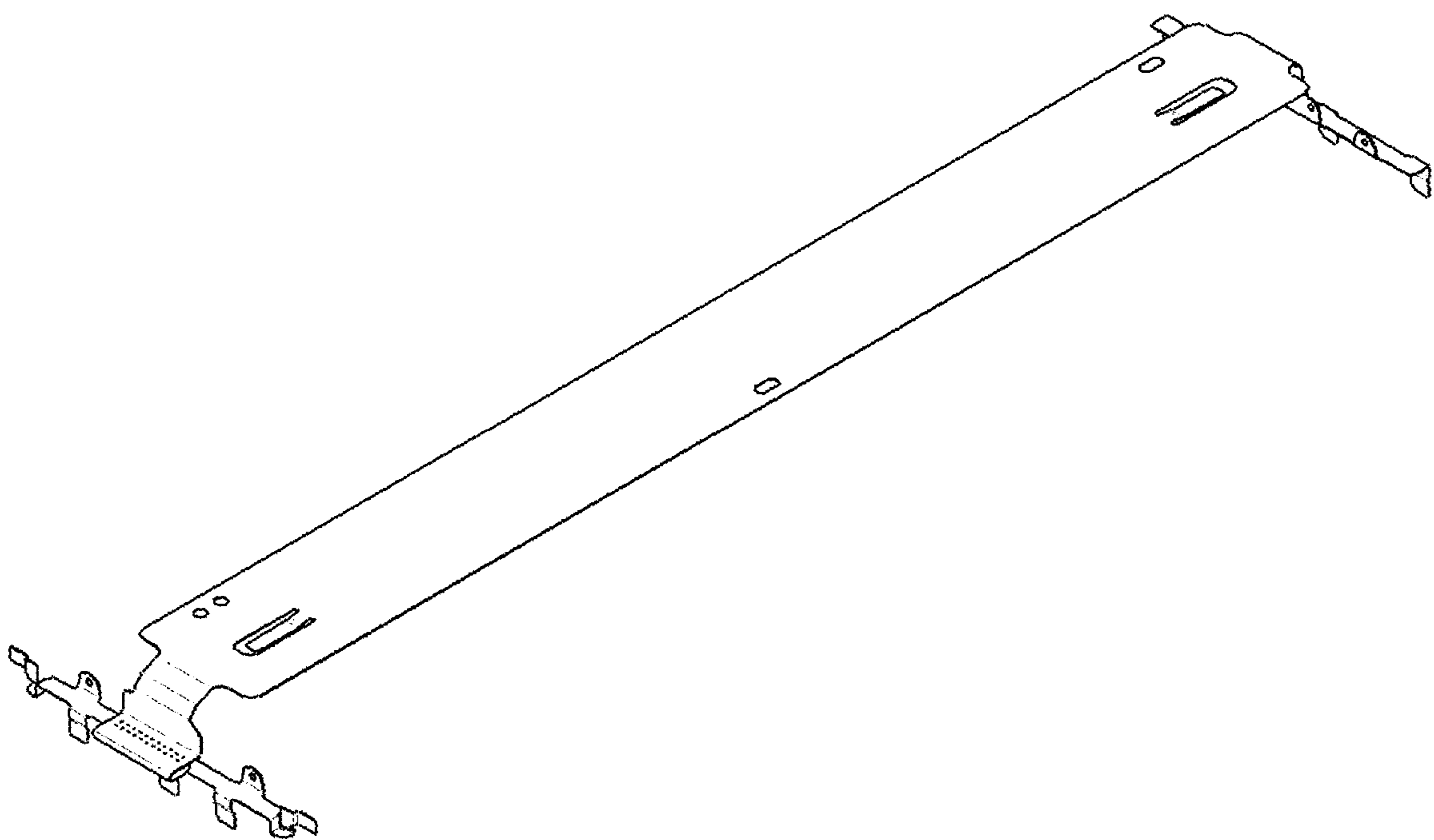

【FIG. 2】

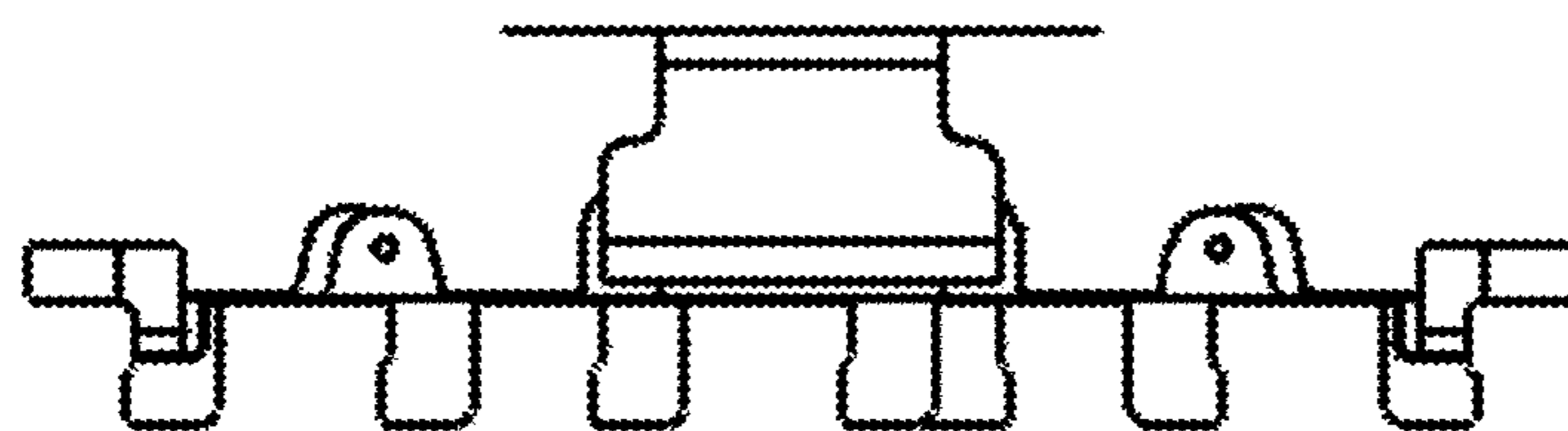

【FIG. 3】

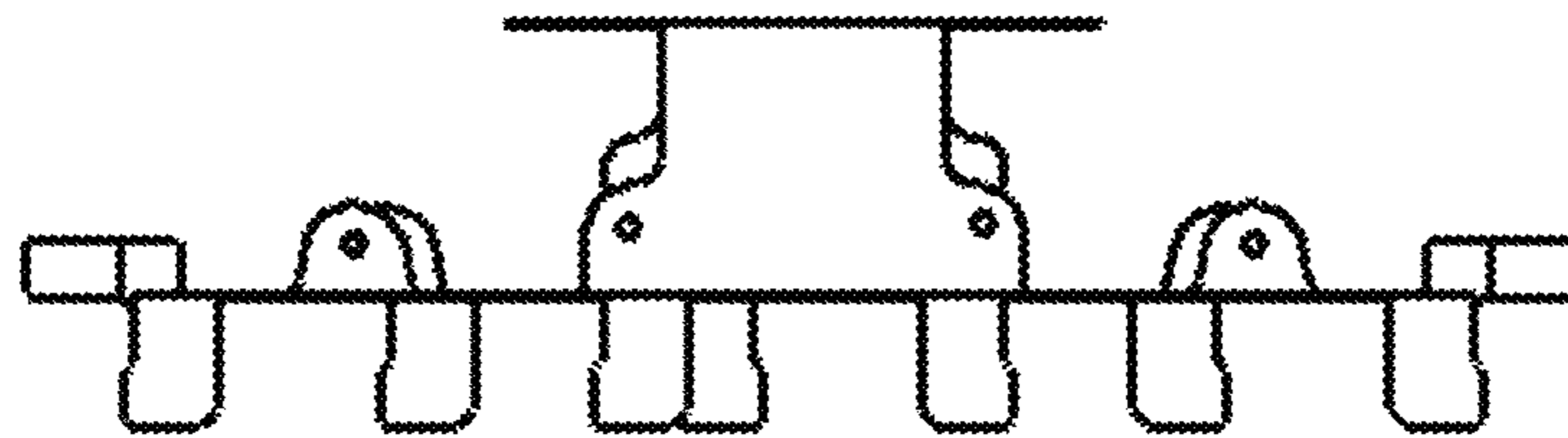

【FIG. 4】



【FIG. 5】



【FIG. 6】

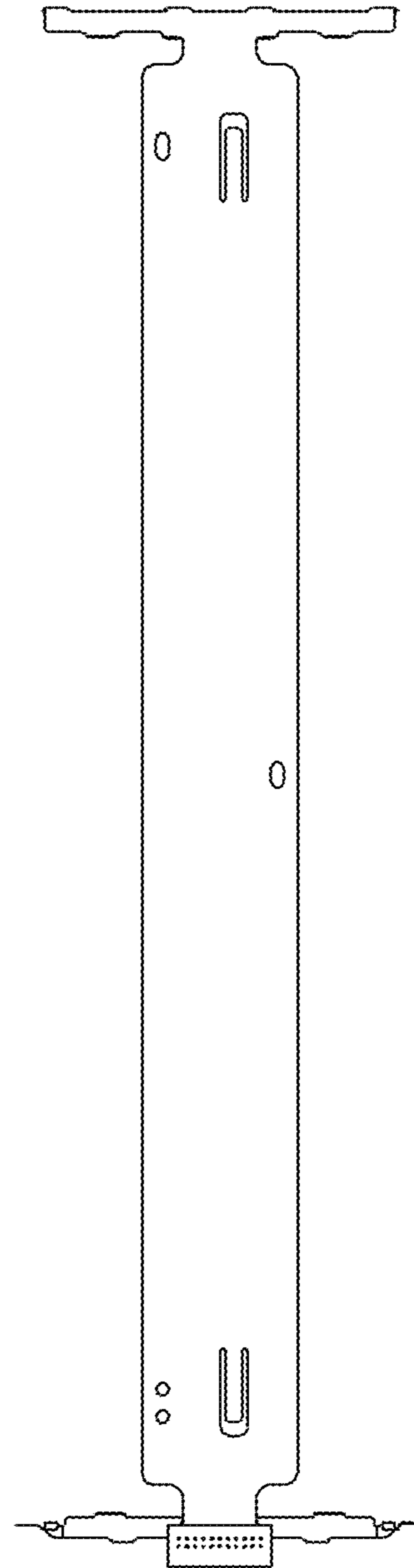

【FIG. 7】

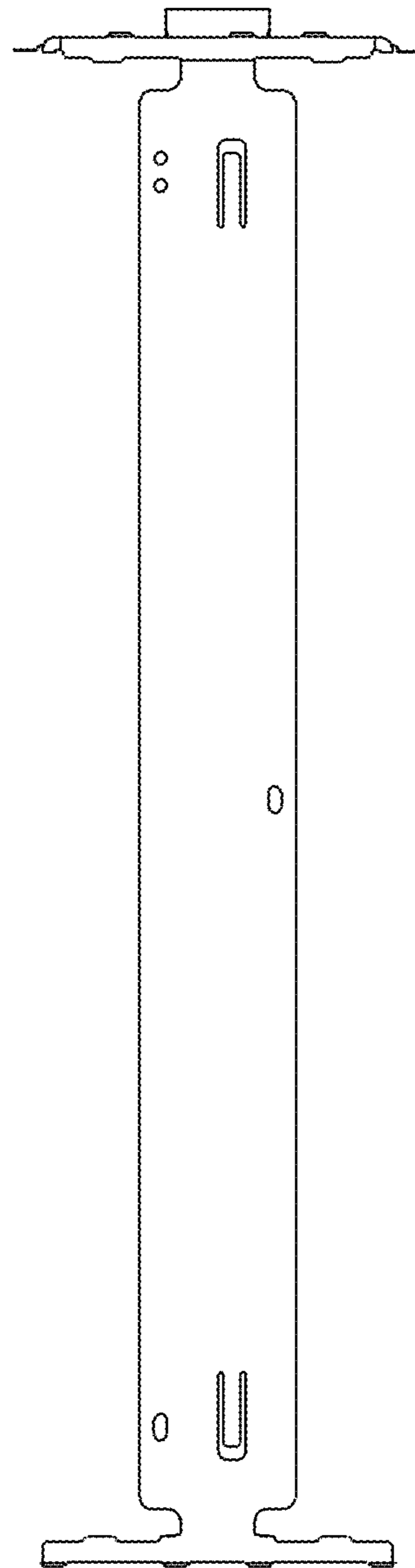

【FIG. 8】

