



US00D937726S

(12) **United States Design Patent**
Meyer et al.

(10) **Patent No.:** **US D937,726 S**

(45) **Date of Patent:** **** Dec. 7, 2021**

(54) **VEHICLE LIFTGATE**

(71) Applicant: **Ford Global Technologies, LLC**,
Dearborn, MI (US)

(72) Inventors: **Anthony Meyer**, Royal Oak, MI (US);
William K. Moore, West Bloomfield,
MI (US); **Adam Riccobelli**, Ferndale,
MI (US); **Thomas Marminc**, Ferndale,
MI (US); **Damon G. Depeyster**,
Northville, MI (US); **Gordon M.**
Platto, Troy, MI (US)

(73) Assignee: **Ford Global Technologies, LLC**,
Dearborn, MI (US)

(**) Term: **15 Years**

(21) Appl. No.: **29/650,701**

(22) Filed: **Jun. 8, 2018**

(51) **LOC (13) Cl.** **12-16**

(52) **U.S. Cl.**
USPC **D12/196**

(58) **Field of Classification Search**
USPC D12/88, 90, 91, 92, 181, 184, 196, 400,
D12/190, 193, 195, 414; D21/424, 433,
D21/434; 296/181.1, 181.5, 198, 181.2,
296/180.1

CPC B62D 25/08; B62D 25/00; B62D 25/02;
B62D 33/0273; B62D 33/033; B62D
24/02; B62D 25/003

See application file for complete search history.

(56) **References Cited**

U.S. PATENT DOCUMENTS

D761,177 S 7/2016 Behmer et al.
D805,985 S * 12/2017 Nakamura D12/196
D811,302 S * 2/2018 Piscitelli D12/196
D816,003 S * 4/2018 Perkins D12/184

D817,815 S * 5/2018 Hubers D12/91
D817,836 S * 5/2018 McMahan D12/196
D818,876 S * 5/2018 Whitla D12/91
D818,877 S * 5/2018 Nakamura D12/91
D818,878 S * 5/2018 McMahan D12/91
D818,879 S * 5/2018 Kochi D12/91
D818,881 S * 5/2018 Bischoff D12/91
D820,182 S * 6/2018 Park D12/196
D820,730 S * 6/2018 Wang D12/91
D821,266 S * 6/2018 Hagino D12/91
D823,761 S * 7/2018 Luk D12/196
D823,763 S * 7/2018 Koo D12/196
D835,019 S * 12/2018 Kim D12/196
D835,557 S * 12/2018 Whitla D12/196
D840,308 S * 2/2019 Schneider D12/196
2016/0318453 A1 * 11/2016 Kowalski B60R 9/042

(Continued)

Primary Examiner — Manpreet S Matharu
Assistant Examiner — Yolanda Robinson

(57) **CLAIM**

The ornamental design for a vehicle liftgate, as shown and described.

DESCRIPTION

FIG. 1 is a front elevational view of a vehicle liftgate, showing our new design;
FIG. 2 is a left side elevational view thereof;
FIG. 3 is a right side elevational view thereof;
FIG. 4 is a top plan view thereof;
FIG. 5 is a bottom plan view thereof;
FIG. 6 is a top, front, and left side perspective view thereof; and,
FIG. 7 is a bottom, front, and left side perspective view thereof.

The broken lines shown in the vehicle liftgate represent a boundary or portions that form no part of the claimed design. The areas within broken lines form no part of the claimed design. The portion of the vehicle liftgate shown in half tone form no part of the claimed design.

1 Claim, 7 Drawing Sheets

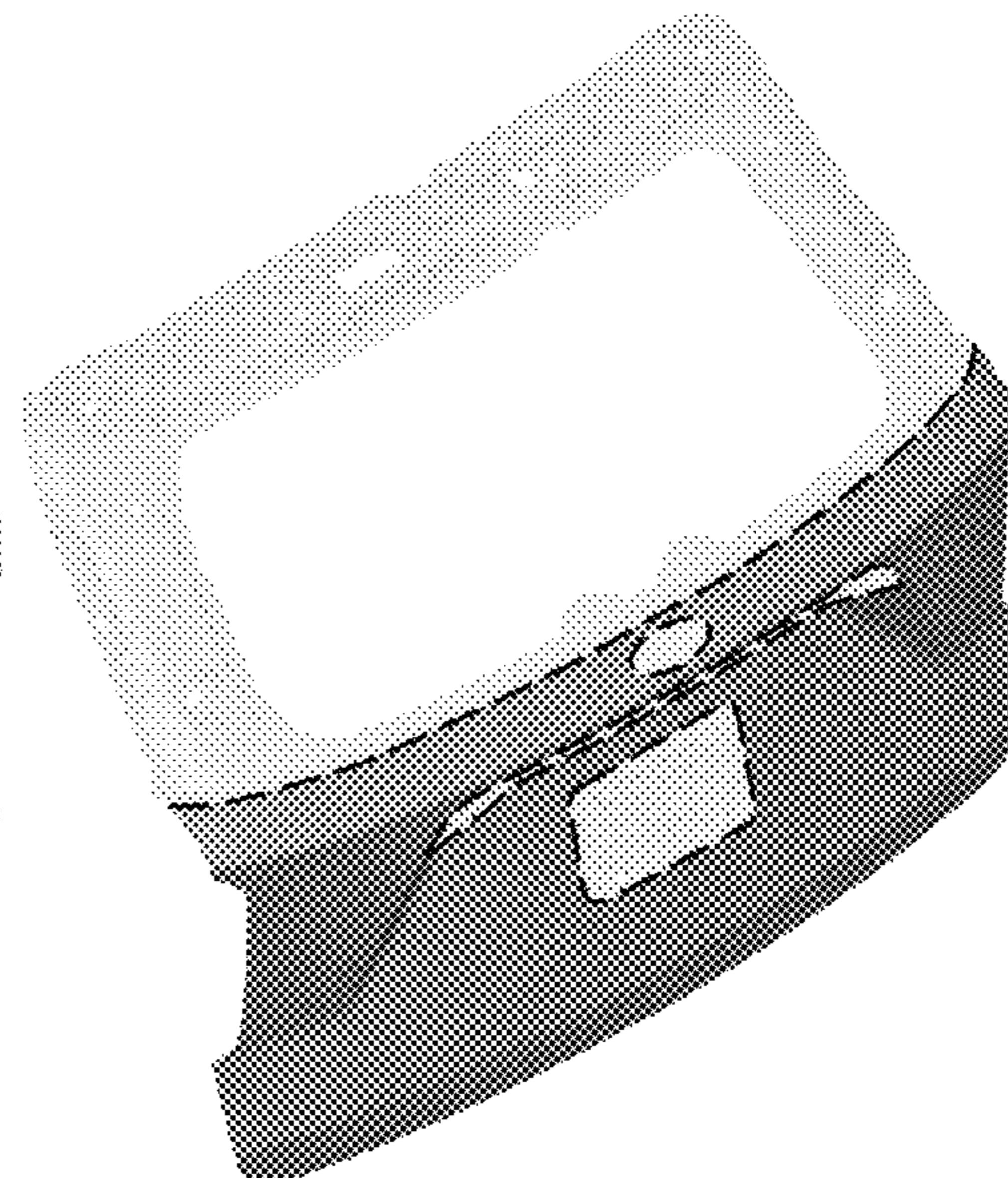
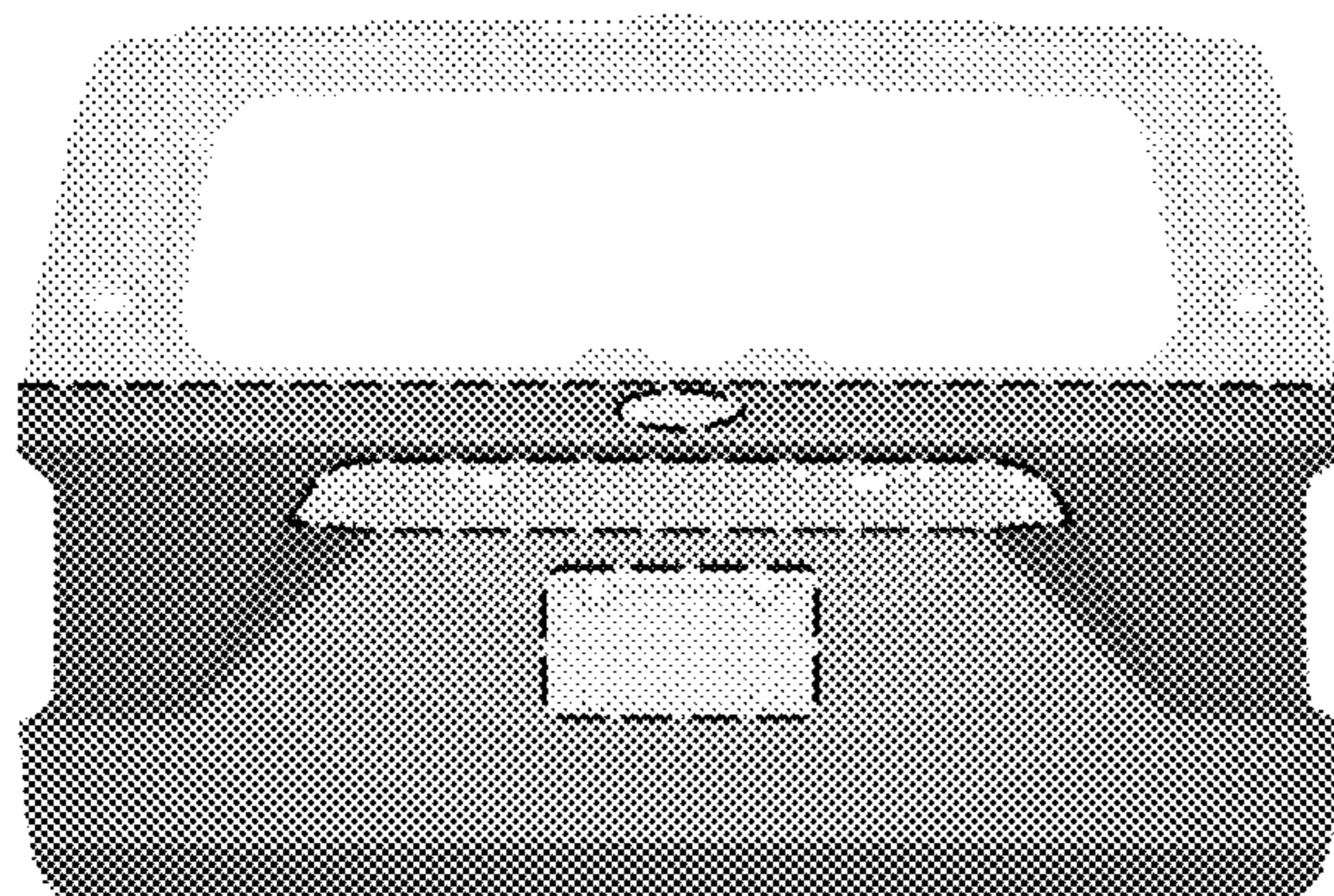

(56)

References Cited

U.S. PATENT DOCUMENTS

2017/0246984 A1* 8/2017 Snider B60Q 1/268
2018/0111455 A1* 4/2018 Felix Frias B60R 5/04

* cited by examiner

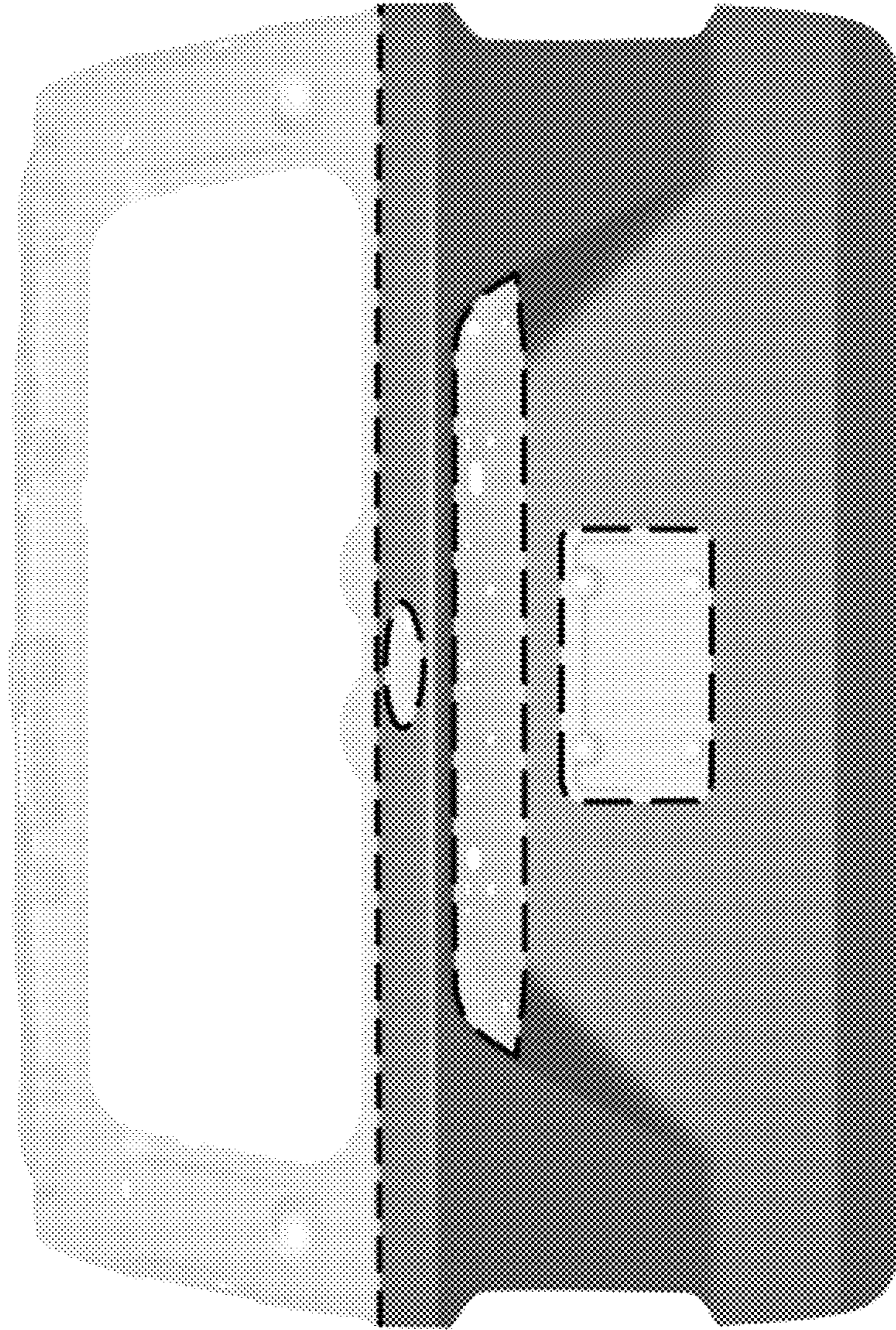

Fig. 1

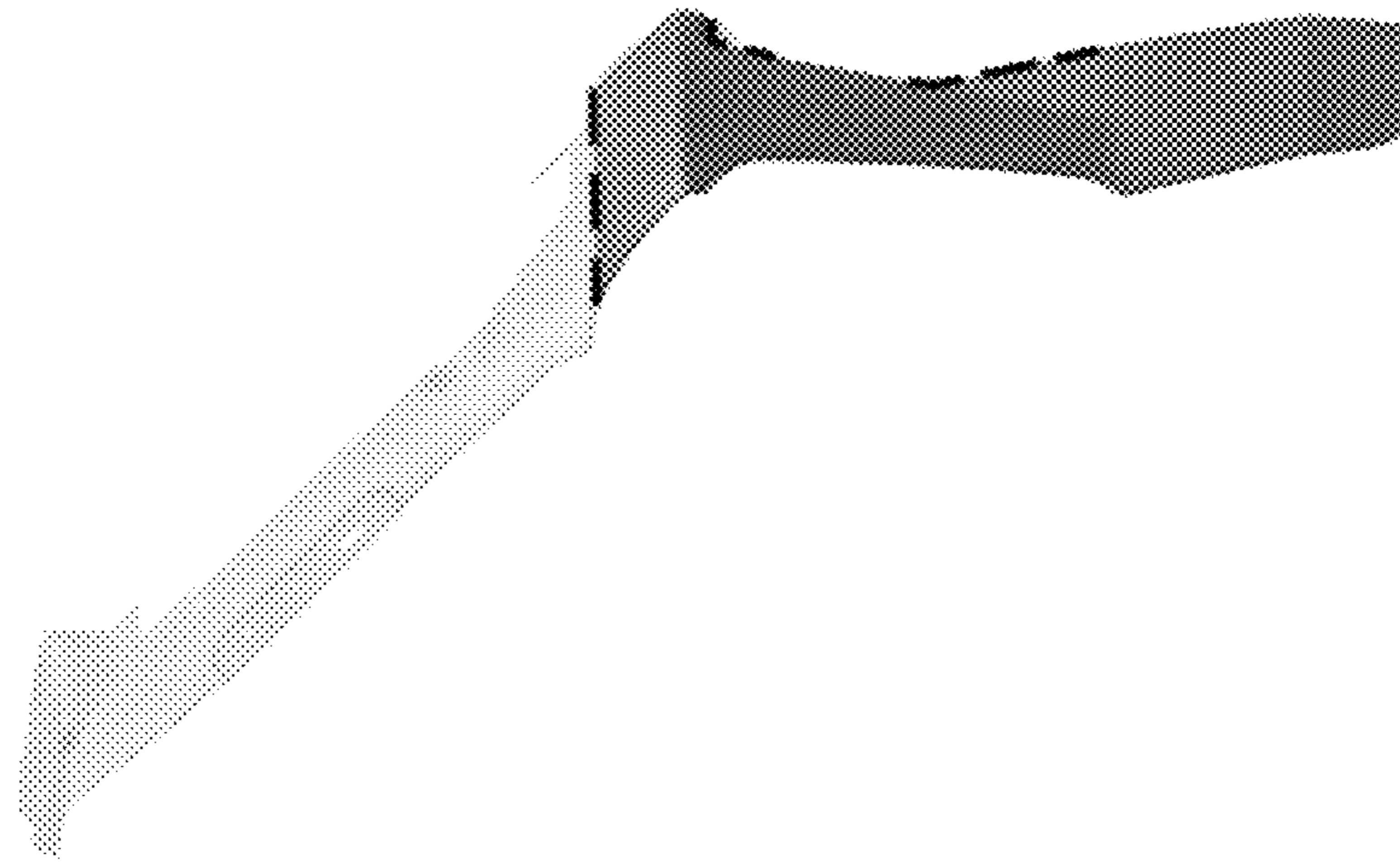

Fig. 2

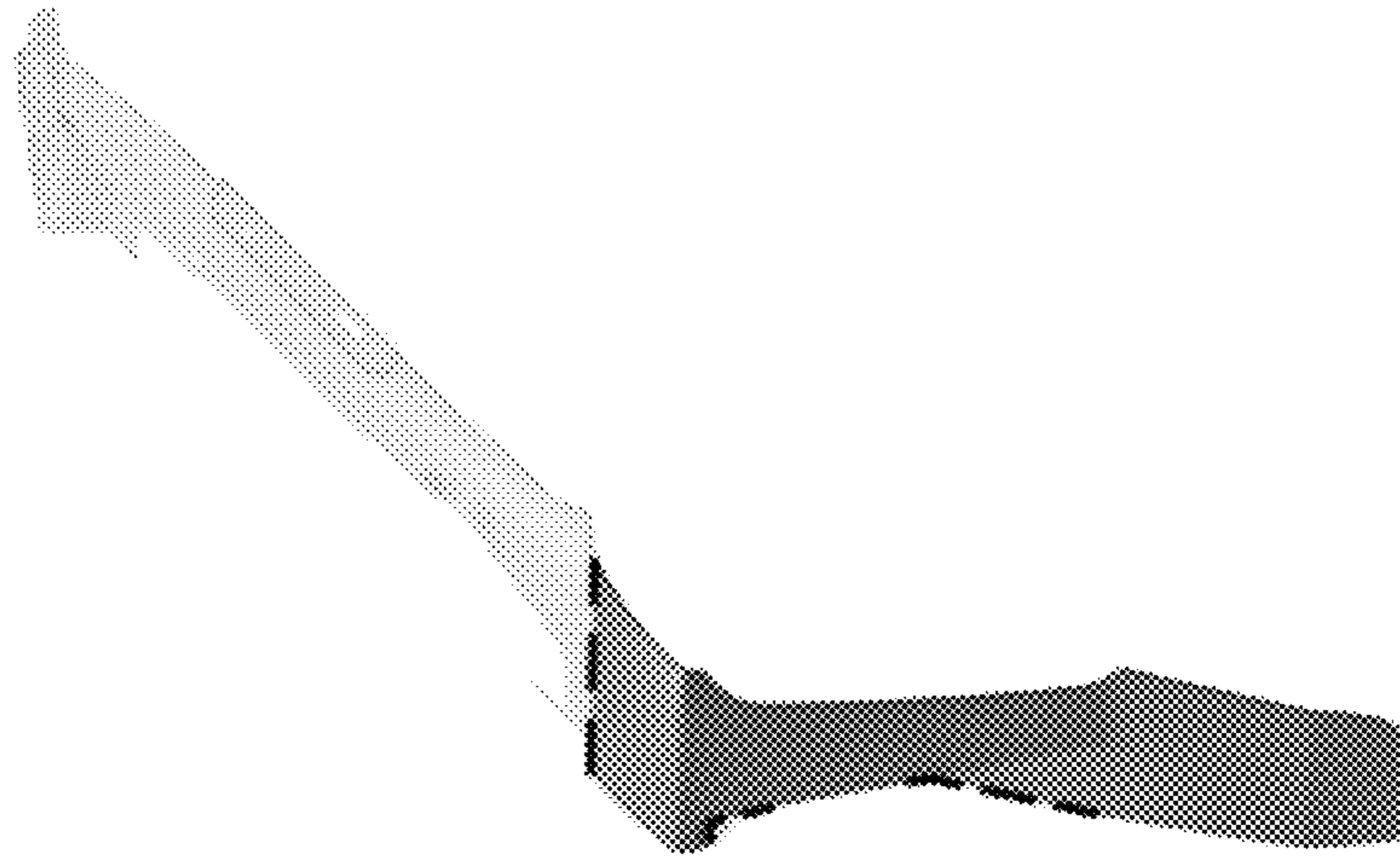

Fig. 3

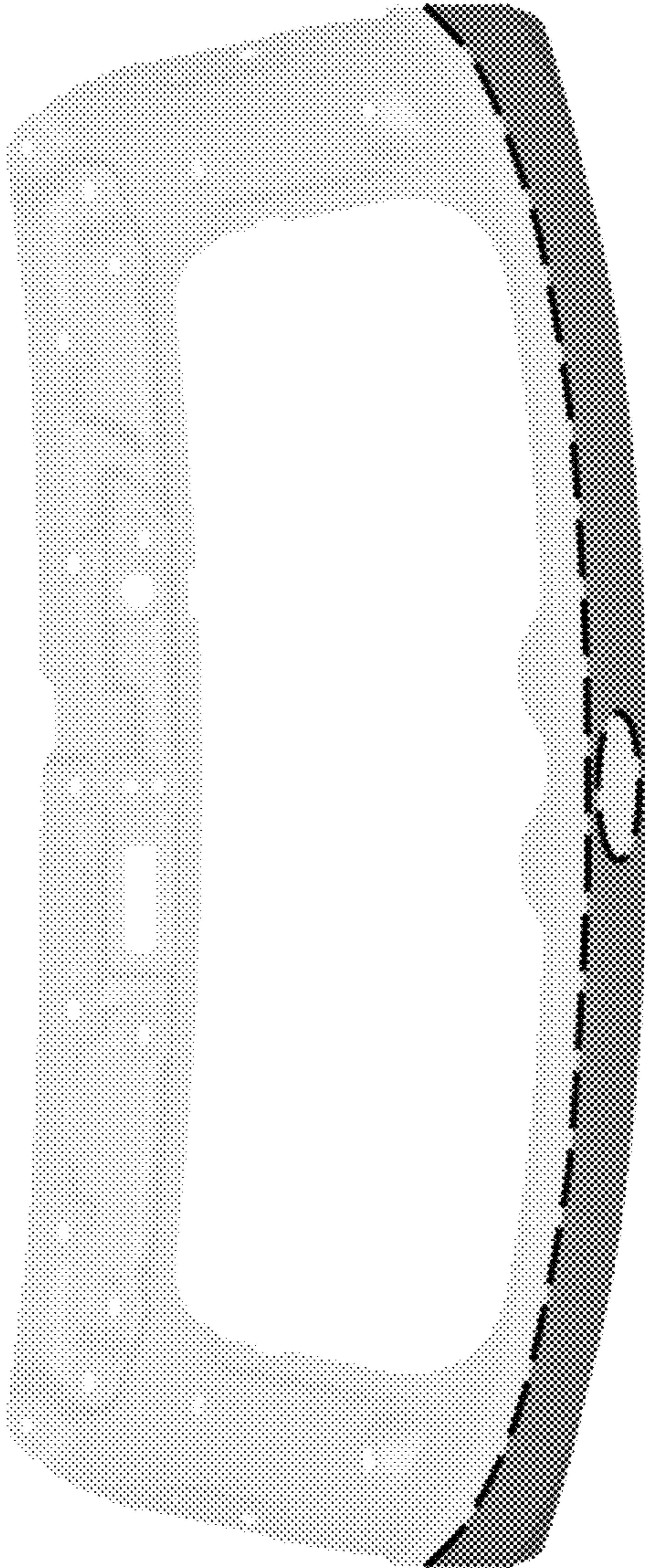

Fig. 4

Fig. 5

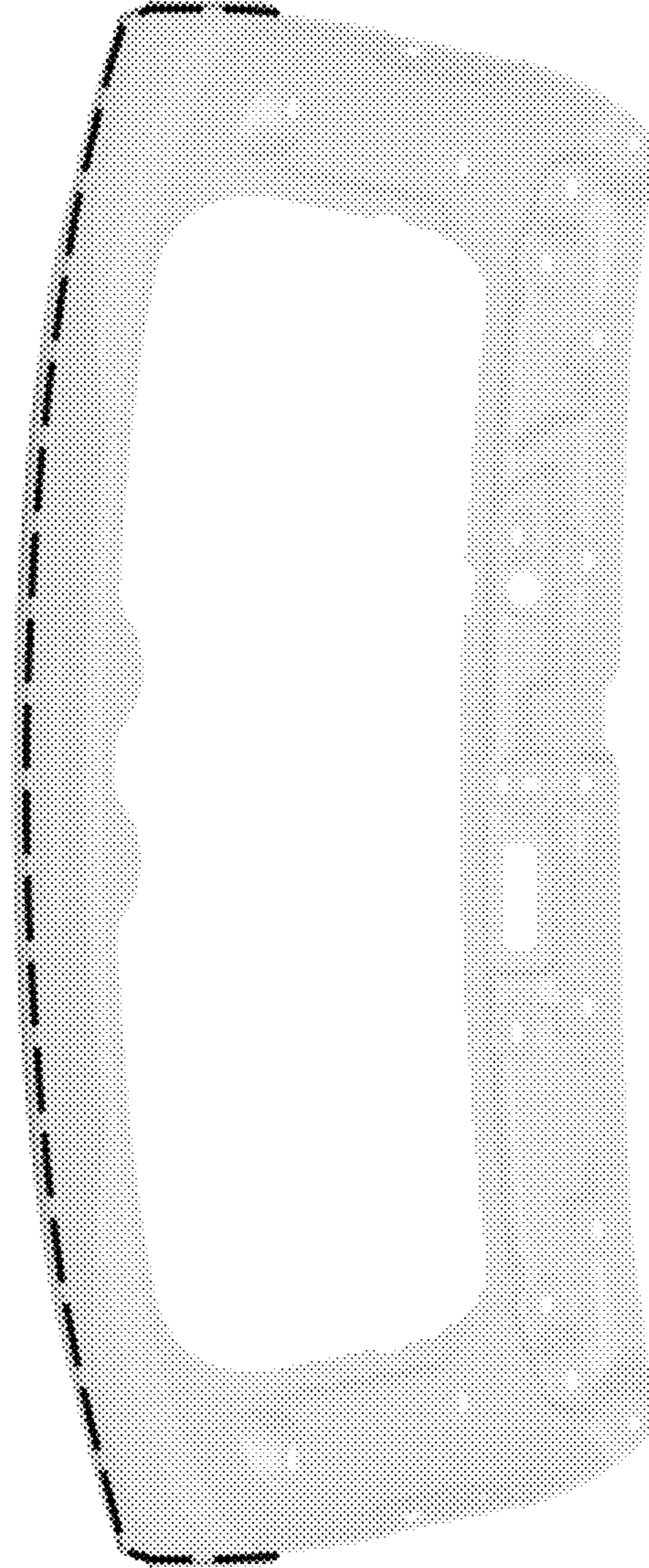



Fig. 6

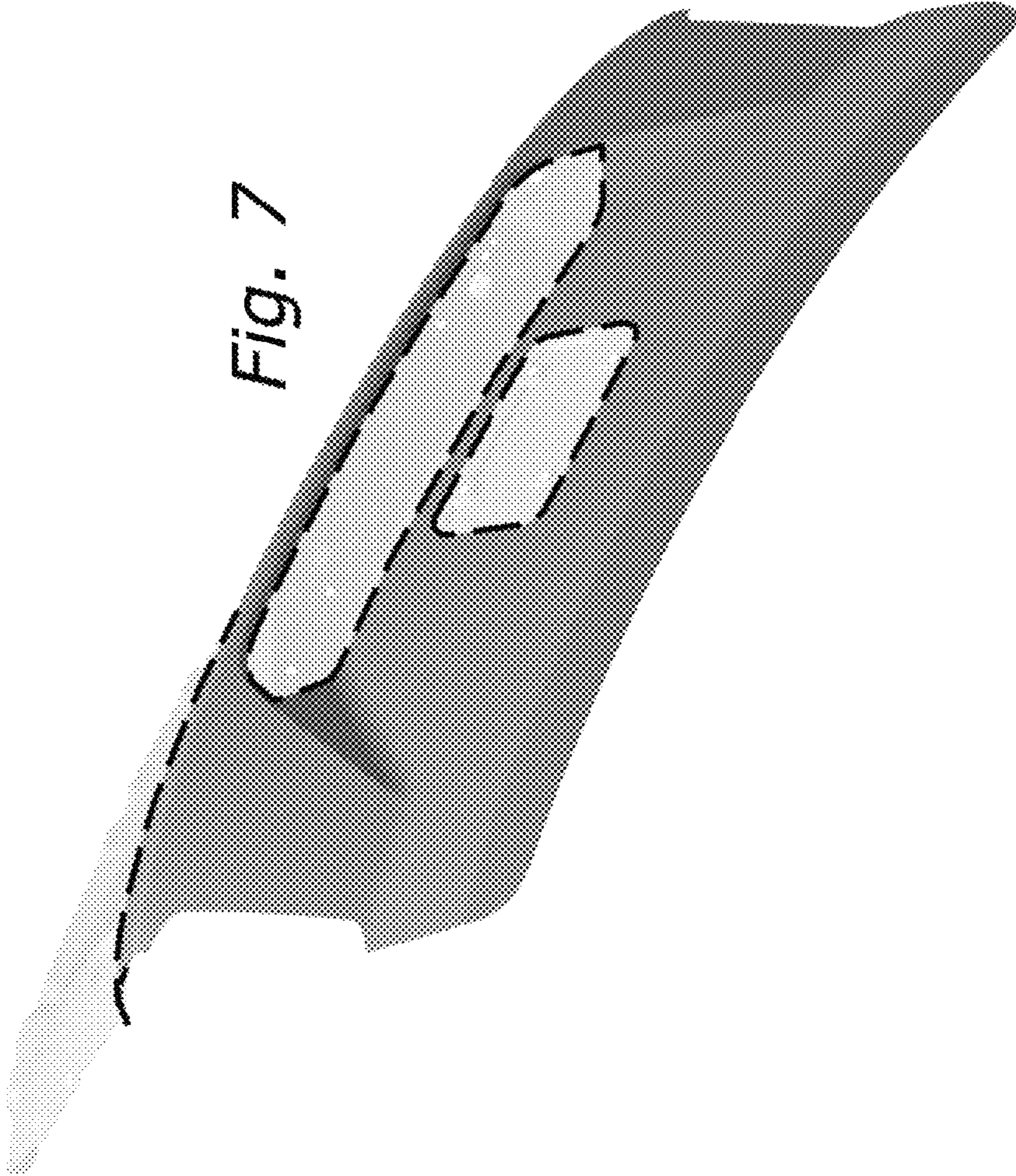

Fig. 7