



US00D937722S

(12) **United States Design Patent** (10) **Patent No.:** **US D937,722 S**  
**Wu** (45) **Date of Patent:** **\*\* Dec. 7, 2021**

(54) **FENDER AIR VENT COVER FOR A VEHICLE**

(71) Applicant: **COMPRESSIVE LTD.**, Taipei (TW)

(72) Inventor: **Chung-Tser Wu**, Taipei (TW)

(73) Assignee: **COMPRESSIVE LTD.**, Taipei (TW)

(\*\*) Term: **15 Years**

(21) Appl. No.: **29/727,586**

(22) Filed: **Mar. 11, 2020**

(30) **Foreign Application Priority Data**

Nov. 5, 2019 (TW) ..... 108306839

(51) **LOC (13) Cl.** ..... **12-16**

(52) **U.S. Cl.**  
USPC ..... **D12/190**

(58) **Field of Classification Search**  
USPC .... D12/190, 181, 192, 400, 90, 91, 92, 196,  
D12/197, 198, 199, 200, 171, 172, 173,  
D12/163, 110, 114  
CPC ..... B60R 13/02; B60R 13/04; B60R 13/043;  
B60R 13/005; B62D 25/00; B62D 25/08;  
B62D 25/24; B60K 11/00; B60K 11/08  
See application file for complete search history.

(56) **References Cited**

U.S. PATENT DOCUMENTS

D548,158 S \* 8/2007 Kulla ..... D12/196  
D685,691 S \* 7/2013 Messale ..... D12/163  
D788,659 S \* 6/2017 Jelec ..... D12/173  
D808,317 S \* 1/2018 Piscitelli ..... D12/190  
D826,798 S \* 8/2018 Behmer ..... D12/163

D829,624 S \* 10/2018 Jamieson ..... D12/196  
D830,239 S \* 10/2018 Behmer ..... D12/163  
D854,992 S \* 7/2019 Pollard ..... D12/190  
D867,250 S \* 11/2019 Goodrich ..... D12/190  
D882,472 S \* 4/2020 Goodrich ..... D12/190  
D899,984 S \* 10/2020 Gregory ..... D12/190  
D909,267 S \* 2/2021 Harvey ..... D12/190  
D916,636 S \* 4/2021 Grand ..... D12/190  
2018/0251162 A1 \* 9/2018 Overgaard ..... B62D 25/24

\* cited by examiner

*Primary Examiner* — Susan E Krakower

*Assistant Examiner* — Jerry Shiuan-Hua Hsu

(74) *Attorney, Agent, or Firm* — Chieh-Mei Wang

(57) **CLAIM**

I claim the ornamental design for a fender air vent cover for a vehicle, as shown and described.

**DESCRIPTION**

FIG. 1 is a top, front, right side perspective view of a fender air vent cover for a vehicle showing our new design; FIG. 2 is a front elevational view thereof; FIG. 3 is a rear elevational view thereof; FIG. 4 is a left side elevational view thereof; FIG. 5 is a right side elevational view thereof; FIG. 6 is a top plan view thereof; FIG. 7 is a bottom plan view thereof; and, FIG. 8 is a top, rear, left side perspective view thereof, shown in a state of use.

The broken lines, in FIGS. 1 to 7, illustrate portions of the fender air vent cover for a vehicle that form no part of the claimed design. The broken lines, in FIG. 8, illustrate environmental structure and form no part of the claimed design.

**1 Claim, 5 Drawing Sheets**

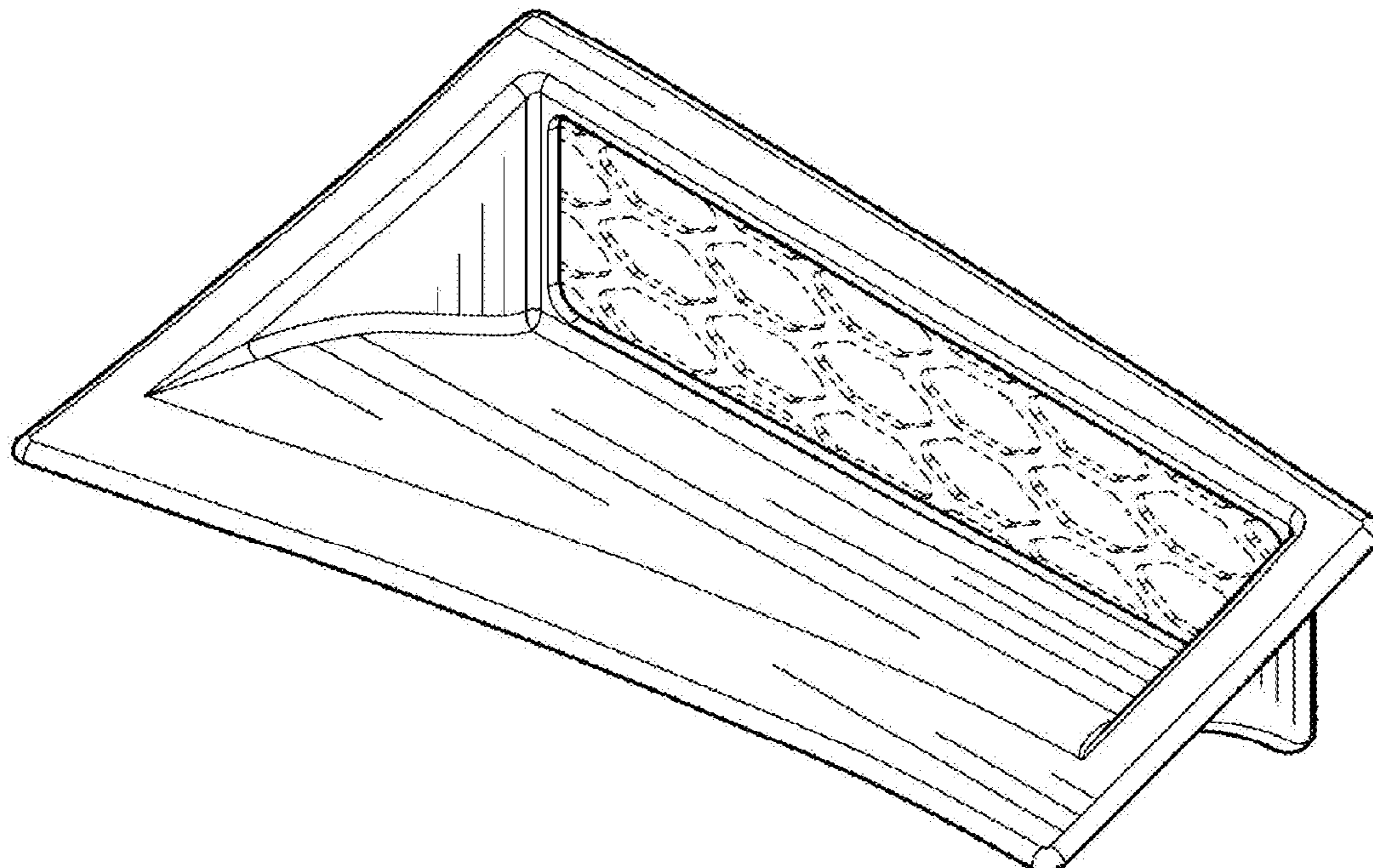

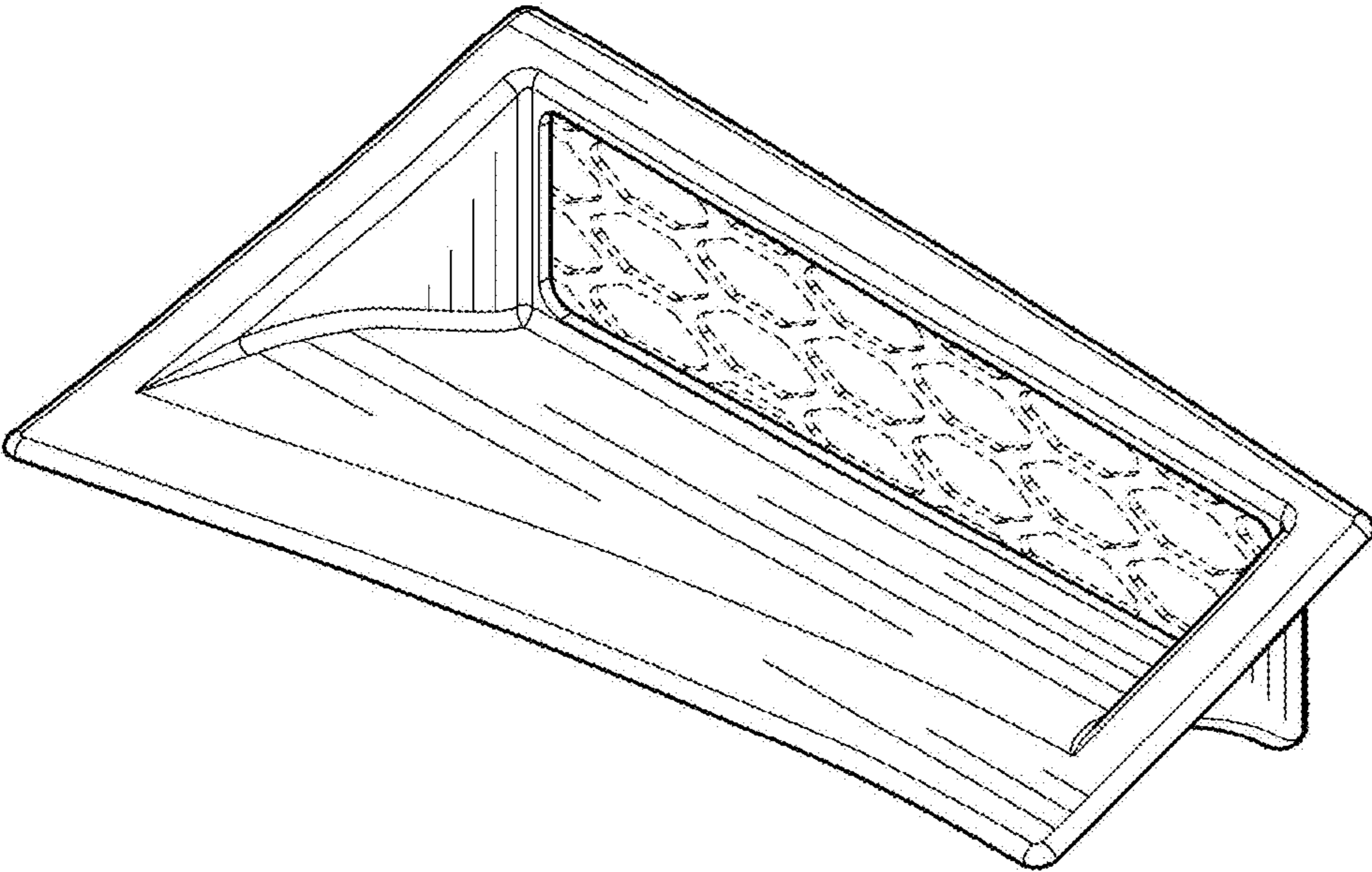

FIG. 1

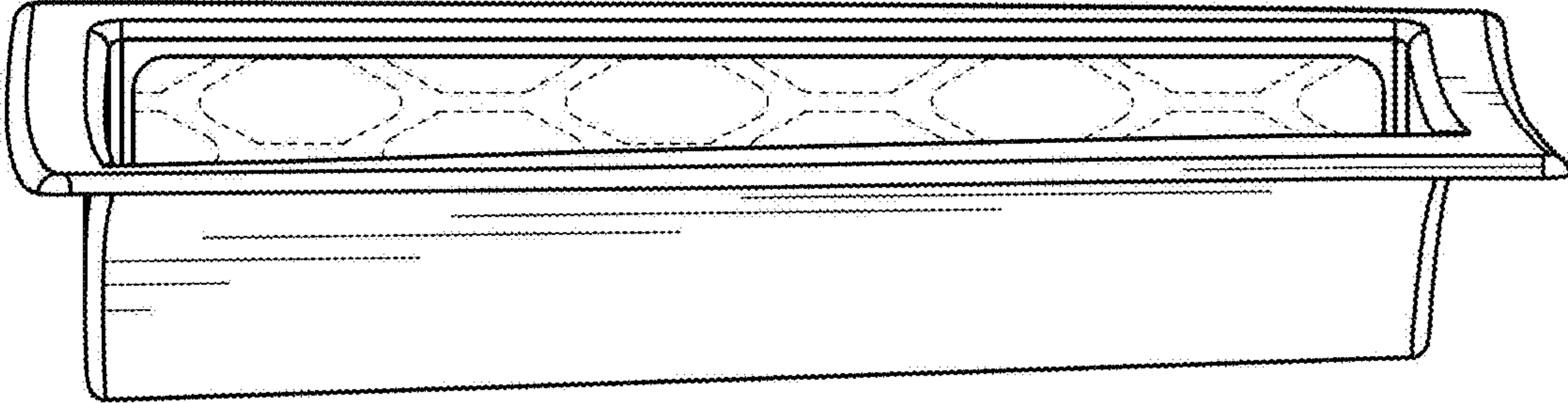

FIG. 2

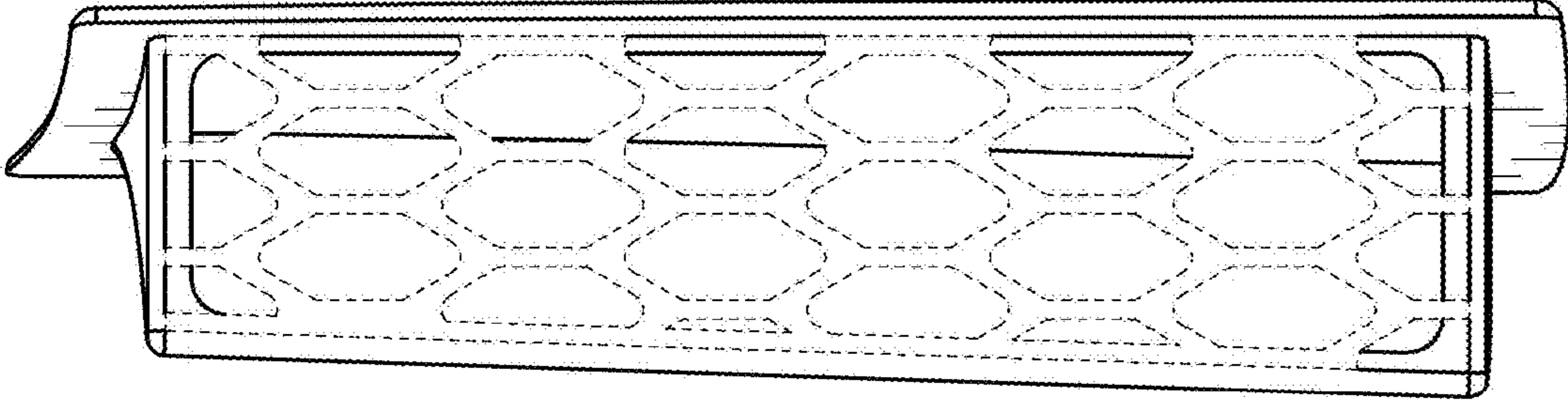

FIG. 3

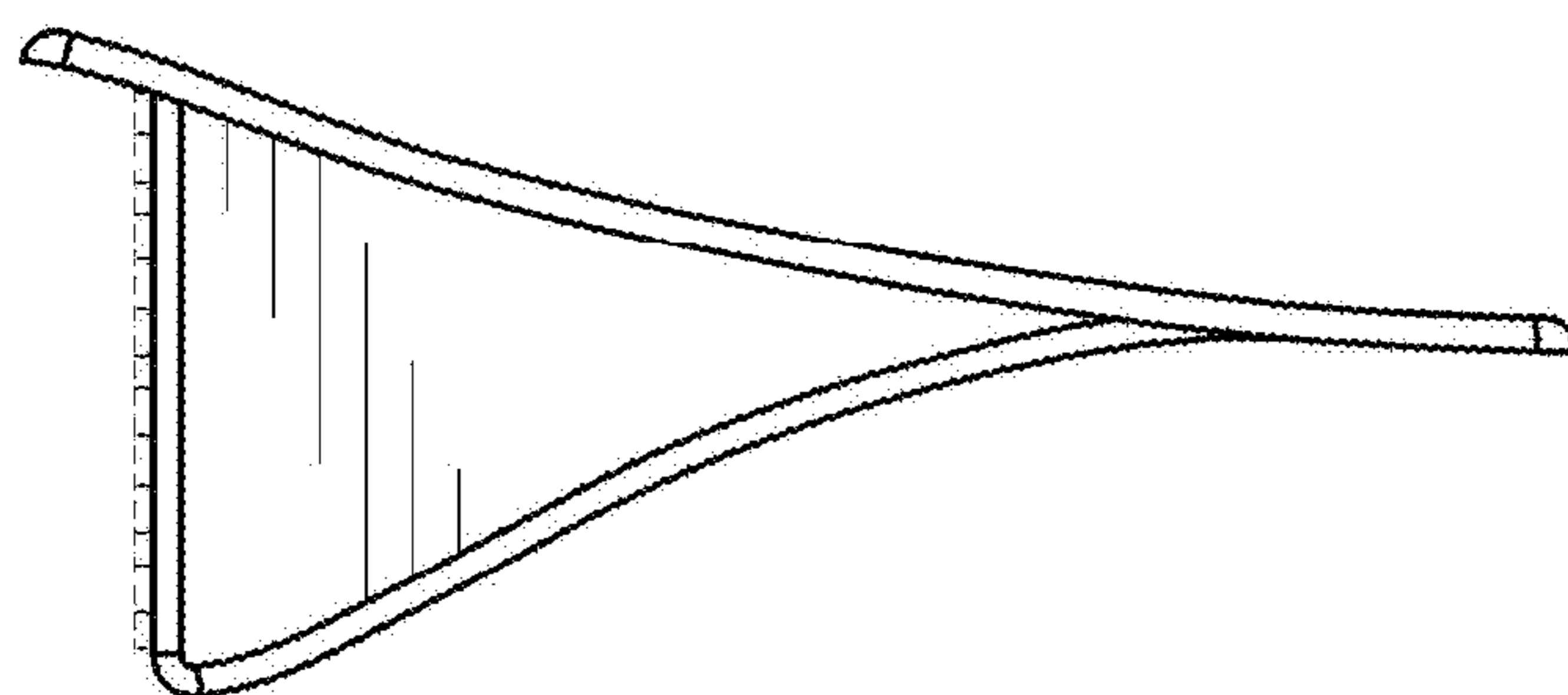

FIG. 4

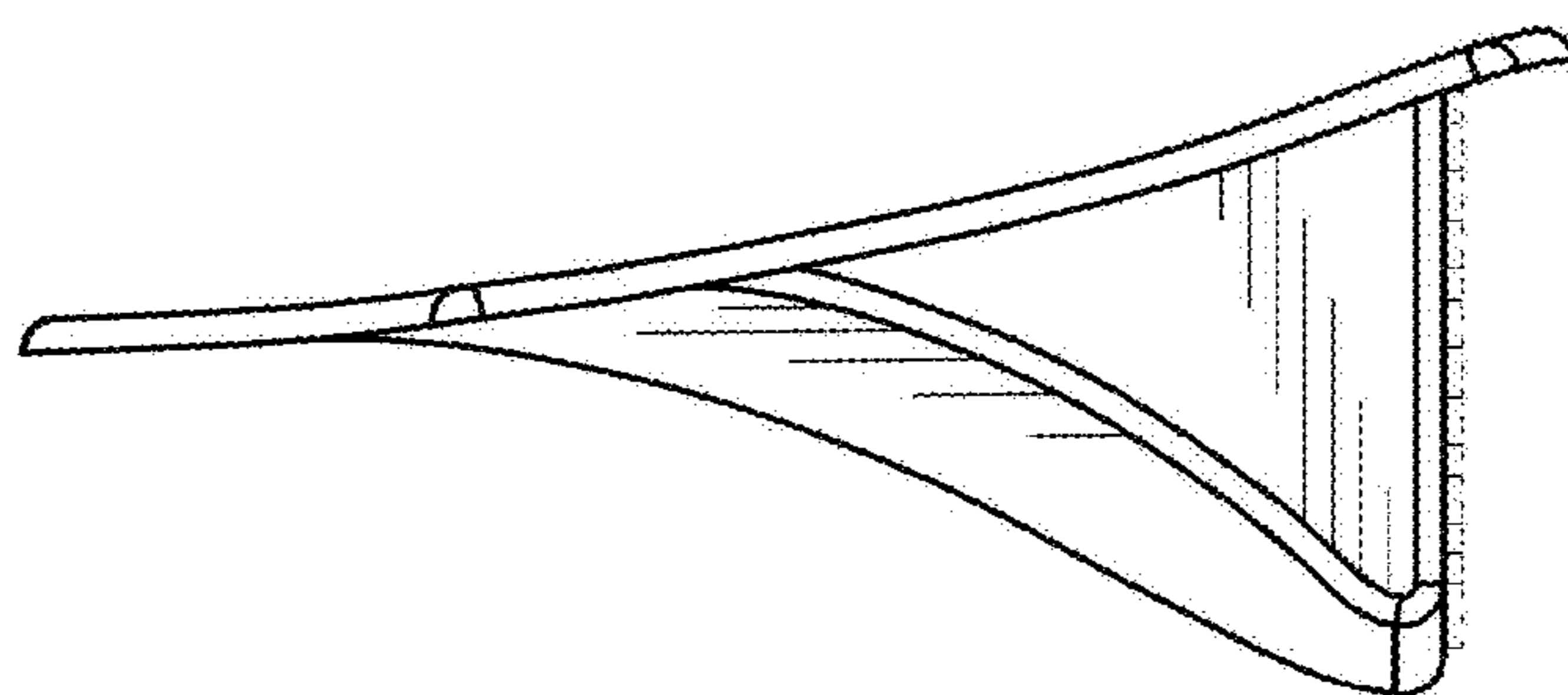

FIG. 5



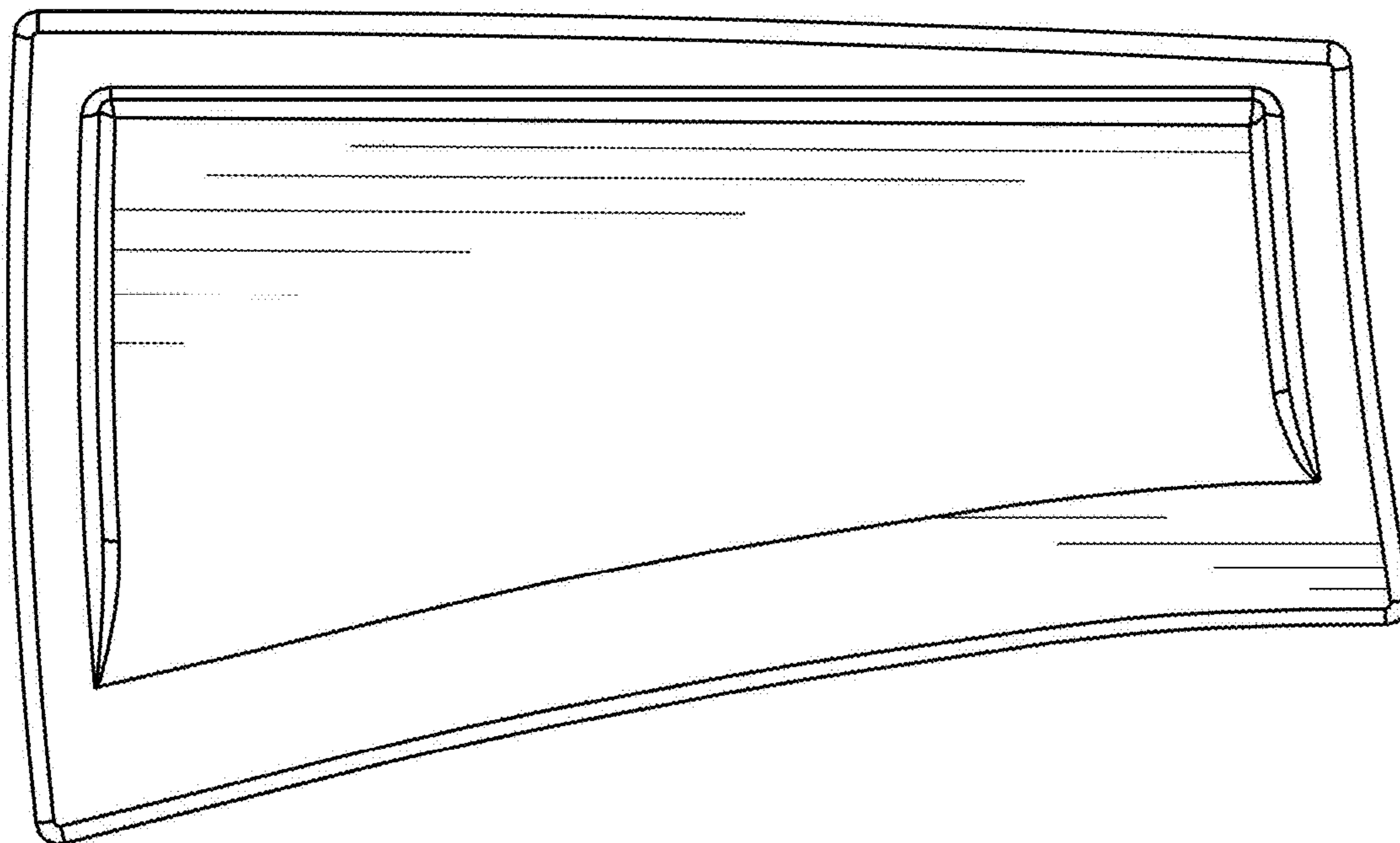

FIG. 6

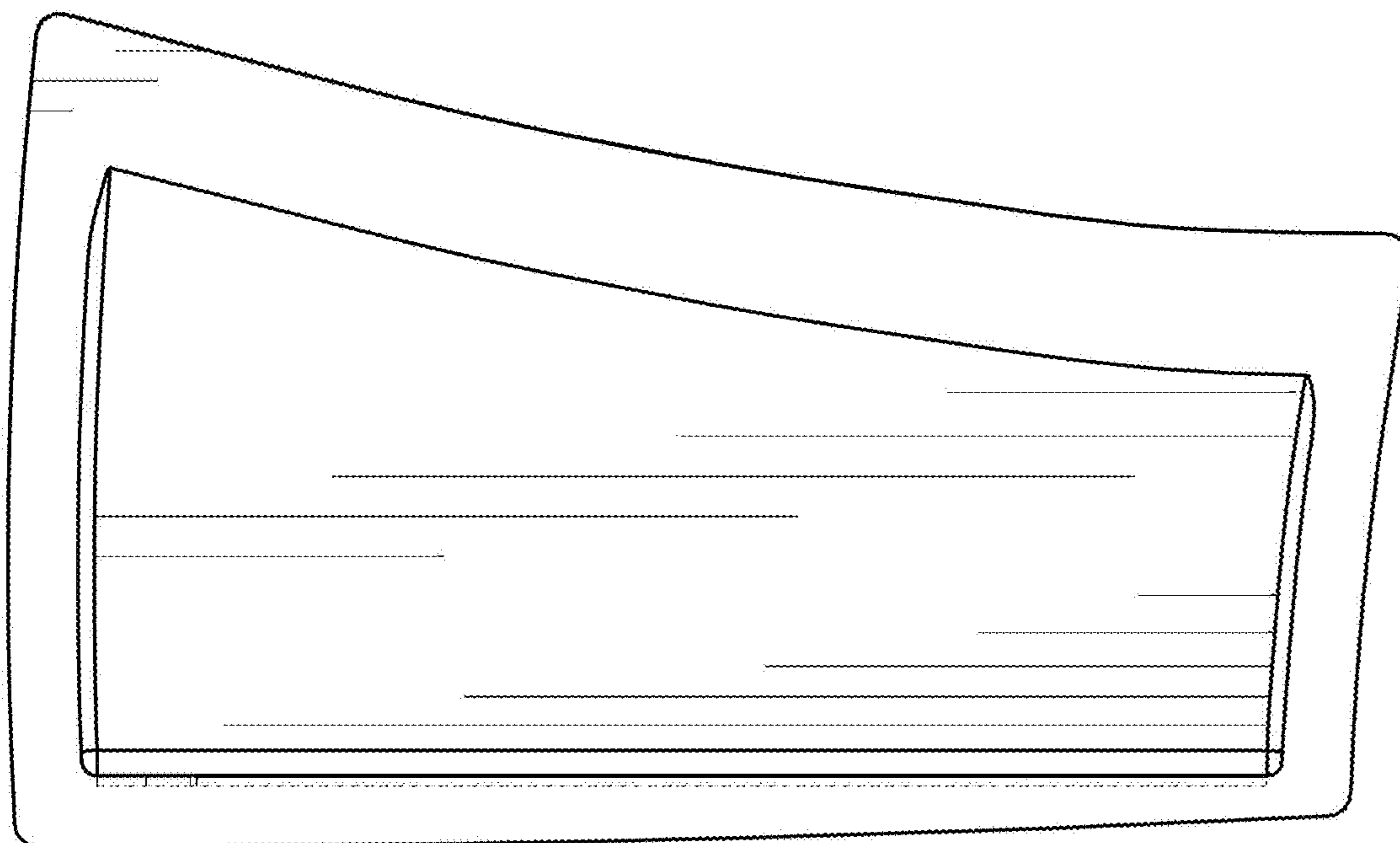

FIG. 7

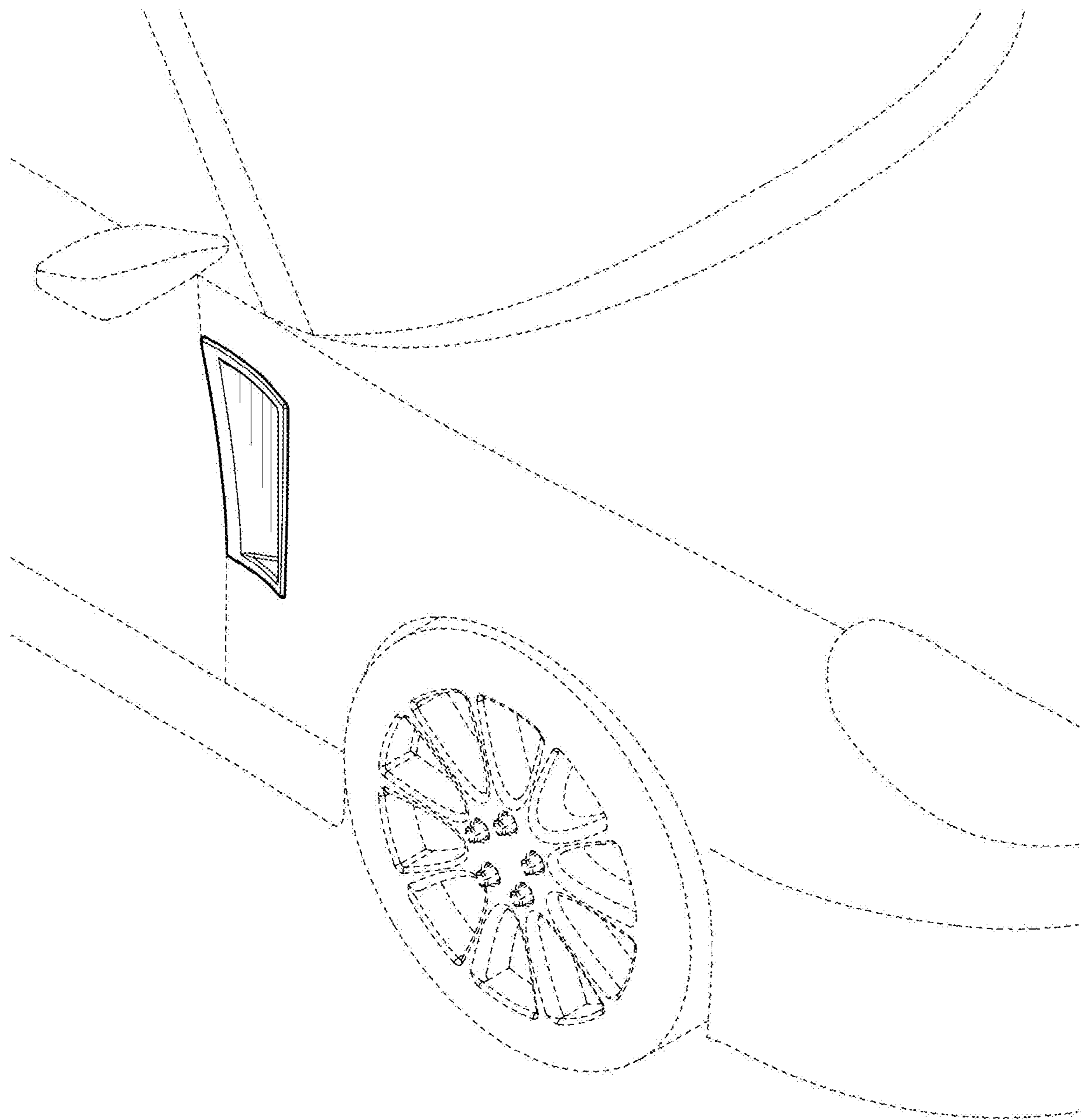

FIG. 8