



US00D937243S

(12) **United States Design Patent** (10) **Patent No.:** **US D937,243 S**  
**Gonzalez** (45) **Date of Patent:** **\*\* Nov. 30, 2021**

(54) **SPEAKER**

- (71) Applicant: **Tempus Labs**, Chicago, IL (US)
- (72) Inventor: **Brianna Gonzalez**, Chicago, IL (US)
- (73) Assignee: **Tempus Labs**, Chicago, IL (US)
- (\*\*) Term: **15 Years**
- (21) Appl. No.: **29/747,227**
- (22) Filed: **Aug. 20, 2020**

**Related U.S. Application Data**

- (63) Continuation of application No. 29/693,538, filed on Jun. 3, 2019, now Pat. No. Des. 897,991.
- (51) **LOC (13) Cl.** ..... **14-03**
- (52) **U.S. Cl.**  
USPC ..... **D14/214**; D14/204
- (58) **Field of Classification Search**  
USPC ..... D14/167, 168, 170–172, 188, 194–196,  
D14/204, 209.1, 210–216, 219, 221, 222,  
D14/224, 239, 496  
CPC ..... B60R 11/0217; G06F 1/1688; G10K 9/22;  
G10K 11/004; H03F 1/327; H04M 1/03;  
H04M 1/035; H04N 5/642; H04N  
21/4852; H04R 1/02; H04R 1/06; H04R  
1/021; H04R 1/025; H04R 1/026; H04R  
1/028; H04R 1/105; H04R 1/323; H04R  
1/403; H04R 1/2803; H04R 1/2834;  
H04R 5/02; H04R 7/20; H04R 9/06;  
H04R 9/025; H04R 2201/021; H04R  
2400/00; H04R 2400/07; H04R 2499/11;  
H04R 2499/13; H04R 2499/15; H04S  
3/00; H04S 7/30

See application file for complete search history.

(56) **References Cited**

U.S. PATENT DOCUMENTS

D110,333 S ‡	7/1938	Aizic .....	D9/526
D229,066 S ‡	11/1973	Ekdahl et al. ....	D14/213
D230,489 S ‡	2/1974	Everitt .....	D14/21
D242,259 S ‡	11/1976	Babb et al. ....	D14/21
D247,489 S ‡	3/1978	Jabara .....	D14/21
D278,032 S ‡	3/1985	de Mourgues .....	D9/435
D294,494 S ‡	3/1988	Kountz .....	D14/214
D305,659 S ‡	1/1990	Fuke .....	D14/17
D324,685 S ‡	3/1992	Strohbeen .....	D14/210

(Continued)

FOREIGN PATENT DOCUMENTS

EM	000649074-0001	‡	1/2007
EM	000649074-0001 S		1/2007

(Continued)

*Primary Examiner* — Keli L Hill

(74) *Attorney, Agent, or Firm* — Quarles & Brady LLP

(57) **CLAIM**

The ornamental design for a speaker, as shown and described.

**DESCRIPTION**

FIG. 1 is a bottom, front, and left side isometric view of a first embodiment of a speaker, showing my new design; FIG. 2 is a front elevational view of the speaker of FIG. 1; FIG. 3 is a rear elevational view of the speaker of FIG. 1; FIG. 4 is a left side elevational view of the speaker of FIG. 1; FIG. 5 is a right side elevational view of the speaker of FIG. 1; FIG. 6 is a top plan view of the speaker of FIG. 1; and, FIG. 7 is a bottom plan view of the speaker of FIG. 1. The dash-dash-dash lines are included for the purpose of illustrating portions that form no part of the claimed design. The dash-dot-dash lines are included for the purpose of illustrating boundary lines and form no part of the claimed design.

**1 Claim, 7 Drawing Sheets**

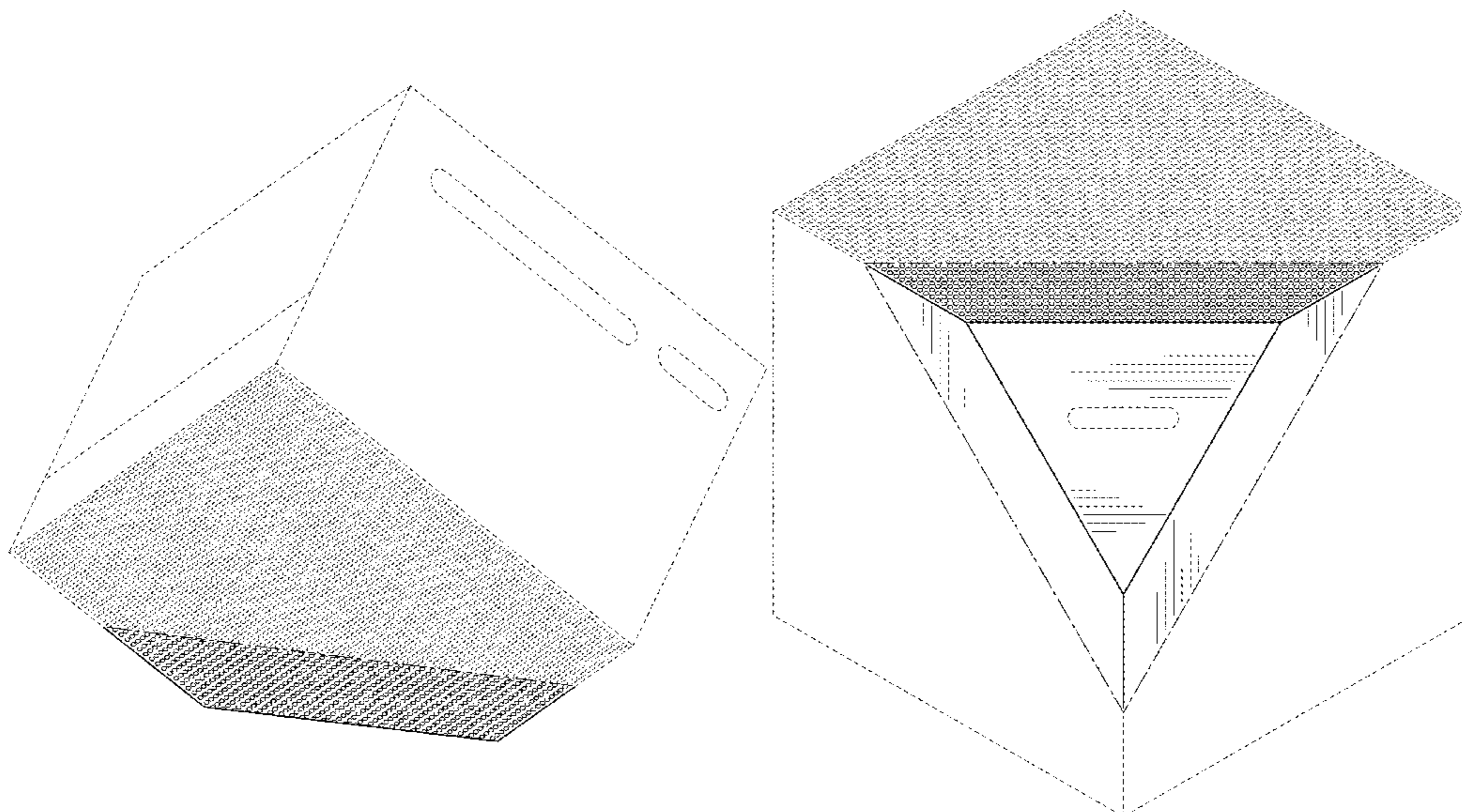

(56)

References Cited

U.S. PATENT DOCUMENTS

D324,686 S ‡ 3/1992 Strohbeen ..... D14/210  
 5,106,015 A \* 4/1992 Vlasaty ..... B65D 5/746  
 222/540  
 D335,474 S ‡ 5/1993 Patterson, Jr. .... D14/21  
 D401,850 S \* 12/1998 Srinaul ..... D9/423  
 D406,845 S ‡ 3/1999 Goto ..... D14/214  
 D430,565 S ‡ 9/2000 Crane, Jr. .... 273/14  
 D435,538 S ‡ 12/2000 Osborne ..... D14/21  
 D442,165 S ‡ 5/2001 Cho ..... D14/21  
 D478,811 S ‡ 8/2003 Huang ..... D3/294  
 D500,297 S ‡ 12/2004 Chan ..... D14/14  
 D557,256 S ‡ 12/2007 Joseph ..... D14/21  
 D565,544 S ‡ 4/2008 Han ..... D14/21  
 D586,777 S ‡ 2/2009 Joseph ..... D10/2  
 D612,837 S ‡ 3/2010 Murray ..... D14/21  
 D626,938 S ‡ 11/2010 Moore ..... D14/21  
 D630,632 S ‡ 1/2011 Puls ..... D14/35  
 D638,821 S ‡ 5/2011 Hoehn ..... D14/21  
 D639,774 S ‡ 6/2011 Rader ..... D14/20  
 D644,204 S ‡ 8/2011 Poandl ..... D14/21  
 D657,348 S ‡ 4/2012 Shim ..... D14/21  
 D676,421 S ‡ 2/2013 Garrett ..... H04R 1/403  
 D14/214  
 D690,280 S ‡ 9/2013 Schul ..... D14/18  
 D691,983 S ‡ 10/2013 Vaughan ..... D14/17  
 D692,411 S ‡ 10/2013 Joseph ..... D14/21  
 D711,237 S ‡ 8/2014 Fleischhacker ..... D9/526  
 D714,249 S ‡ 9/2014 Carney ..... D14/140  
 D718,275 S ‡ 11/2014 Shim ..... D14/21  
 D718,714 S ‡ 12/2014 Si ..... D13/11  
 D718,715 S ‡ 12/2014 Si ..... D13/11  
 D723,479 S ‡ 3/2015 Lee ..... D14/12  
 D725,624 S ‡ 3/2015 Carney ..... D14/14  
 8,967,323 B1 ‡ 3/2015 Grenier ..... H04R 1/403  
 181/198  
 D734,895 S ‡ 7/2015 Liu ..... D28/85  
 D735,415 S ‡ 7/2015 Thompson ..... D28/85  
 D747,697 S ‡ 1/2016 Wildner ..... D14/21  
 D750,046 S ‡ 2/2016 Wong ..... D14/21  
 D754,101 S ‡ 4/2016 McManigal ..... D14/21  
 D754,102 S ‡ 4/2016 Sun ..... D14/214

D754,103 S ‡ 4/2016 Fischer ..... D14/214  
 D755,160 S ‡ 5/2016 Ponce ..... D14/21  
 D756,913 S \* 5/2016 Esses ..... D13/107  
 D758,345 S ‡ 6/2016 Fujioka ..... D14/214  
 D761,230 S ‡ 7/2016 Si ..... D14/21  
 D763,819 S ‡ 8/2016 Silvera ..... D14/20  
 D763,825 S ‡ 8/2016 Zamir ..... D14/21  
 D771,018 S ‡ 11/2016 Espinosa ..... D14/21  
 D772,160 S ‡ 11/2016 Roberts ..... D13/11  
 D779,455 S ‡ 2/2017 Balcerzak ..... D14/17  
 D787,513 S ‡ 5/2017 Basil ..... D14/365  
 D791,214 S ‡ 7/2017 Park ..... D16/23  
 D800,095 S ‡ 10/2017 Yao ..... D14/214  
 D808,337 S ‡ 1/2018 Roberts ..... D13/11  
 D811,329 S ‡ 2/2018 Roberts ..... D13/11  
 D815,950 S ‡ 4/2018 Zhang ..... D9/526  
 D816,062 S ‡ 4/2018 Park ..... D14/214  
 D819,593 S ‡ 6/2018 Lee ..... D14/19  
 D826,206 S ‡ 8/2018 Elmieh ..... D14/20  
 D856,976 S ‡ 8/2019 Kang ..... D14/21  
 D865,755 S ‡ 11/2019 Yang ..... D14/30  
 D868,737 S ‡ 12/2019 Roberts ..... D14/21  
 D874,432 S ‡ 2/2020 Savage ..... D14/21  
 D890,720 S \* 7/2020 Le ..... D14/215  
 D897,991 S \* 10/2020 Gonzalez ..... D14/214  
 D905,662 S \* 12/2020 Gonzalez ..... B65D 5/746  
 D14/214  
 2009/0226019 A1 ‡ 9/2009 Koren ..... H04R 1/2819  
 381/34

FOREIGN PATENT DOCUMENTS

EM 000955091-0001 S 6/2008  
 EM 002008904-0001 S 3/2012  
 EM 001376792-0002 S 7/2013  
 EM 002473678-0001 S 5/2014  
 EM 002717926-0001 S 6/2015  
 EM 002717926-0002 S 6/2015  
 EM 003160787-0001 S 6/2015  
 HK 1501623.9M001 10/2015  
 JP 1582820 S 7/2017  
 TW D122039 3/2008

\* cited by examiner  
 ‡ imported from a related application

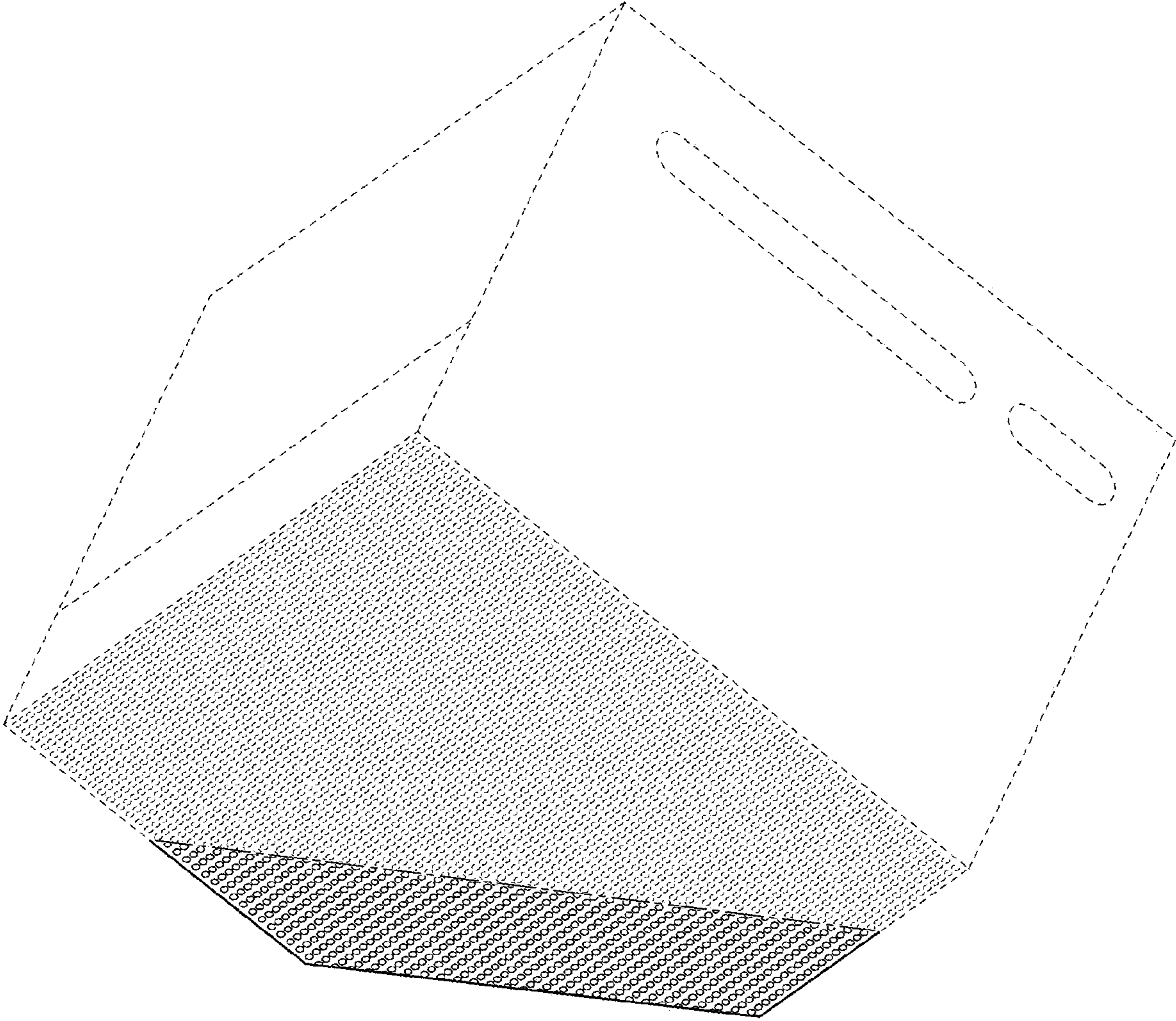

FIG. 1

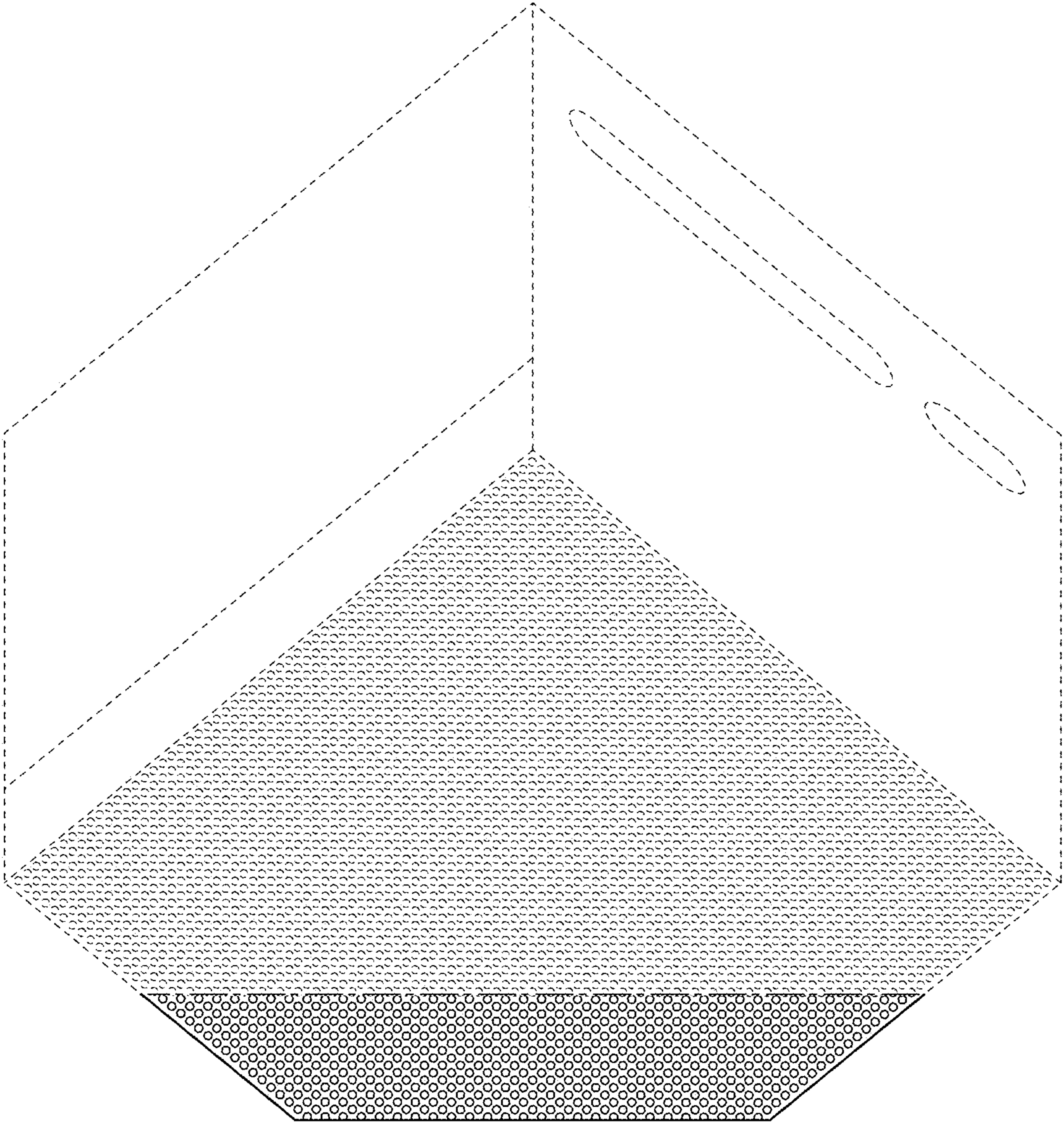

FIG. 2

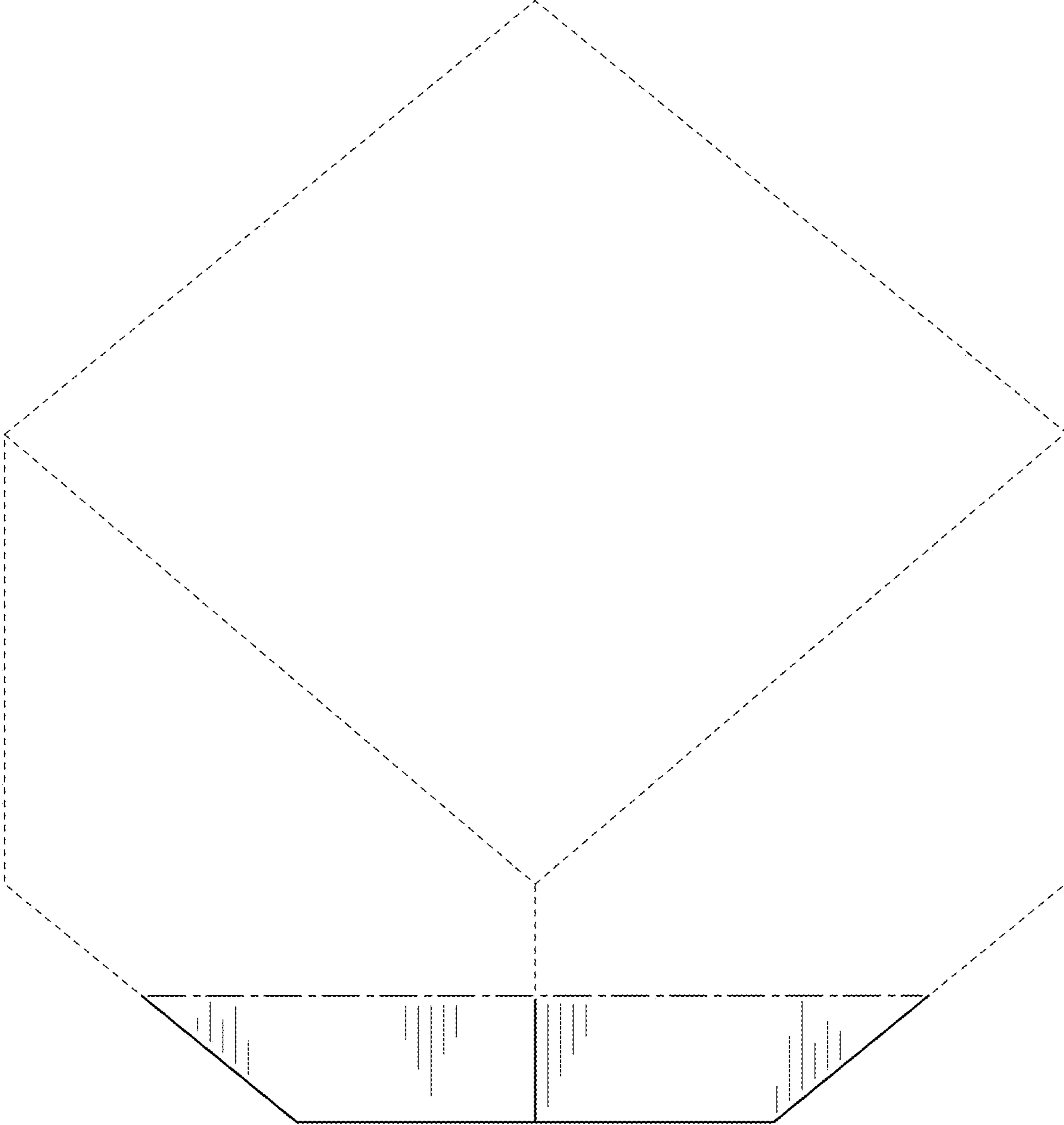

FIG. 3

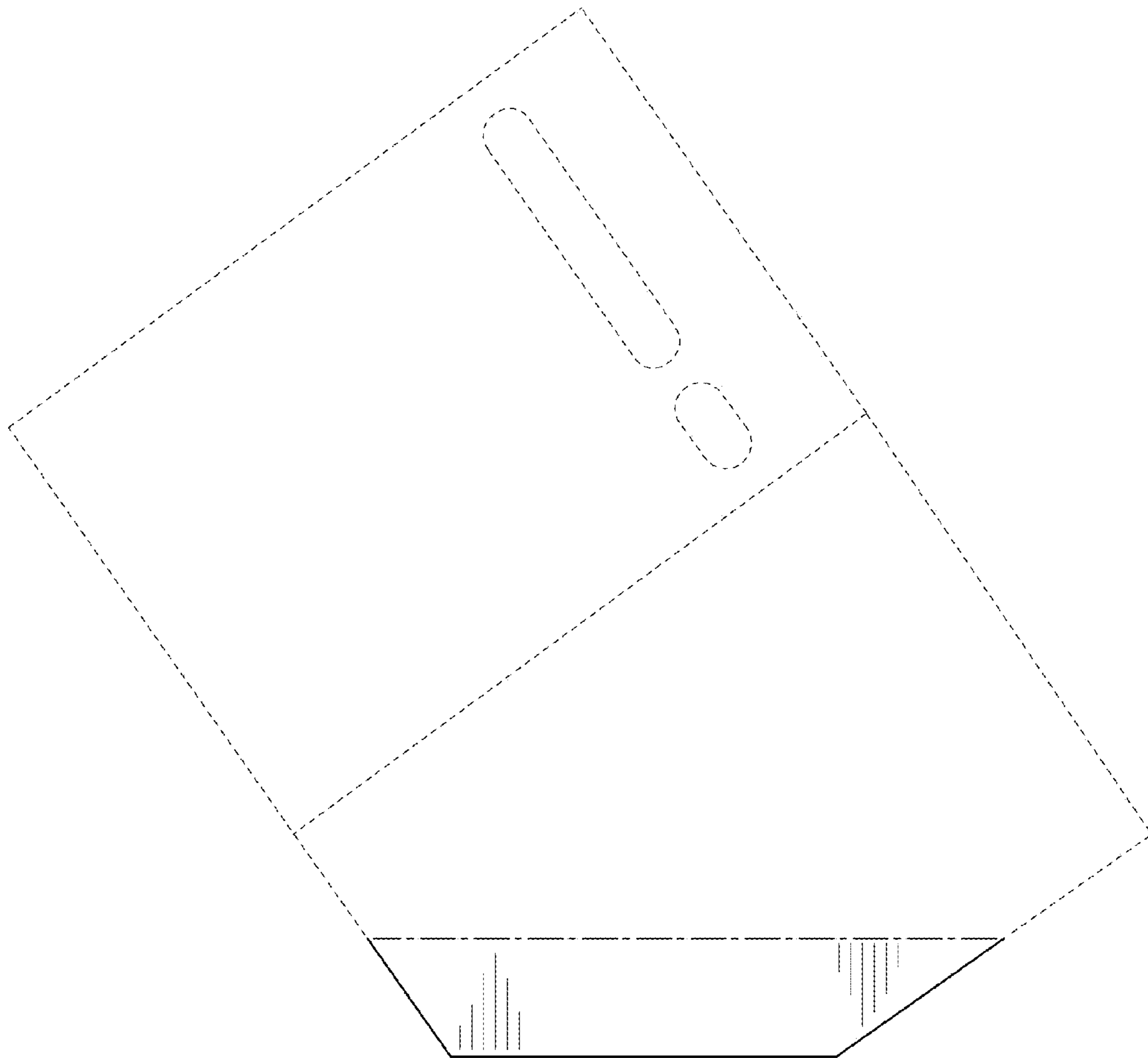

FIG. 4

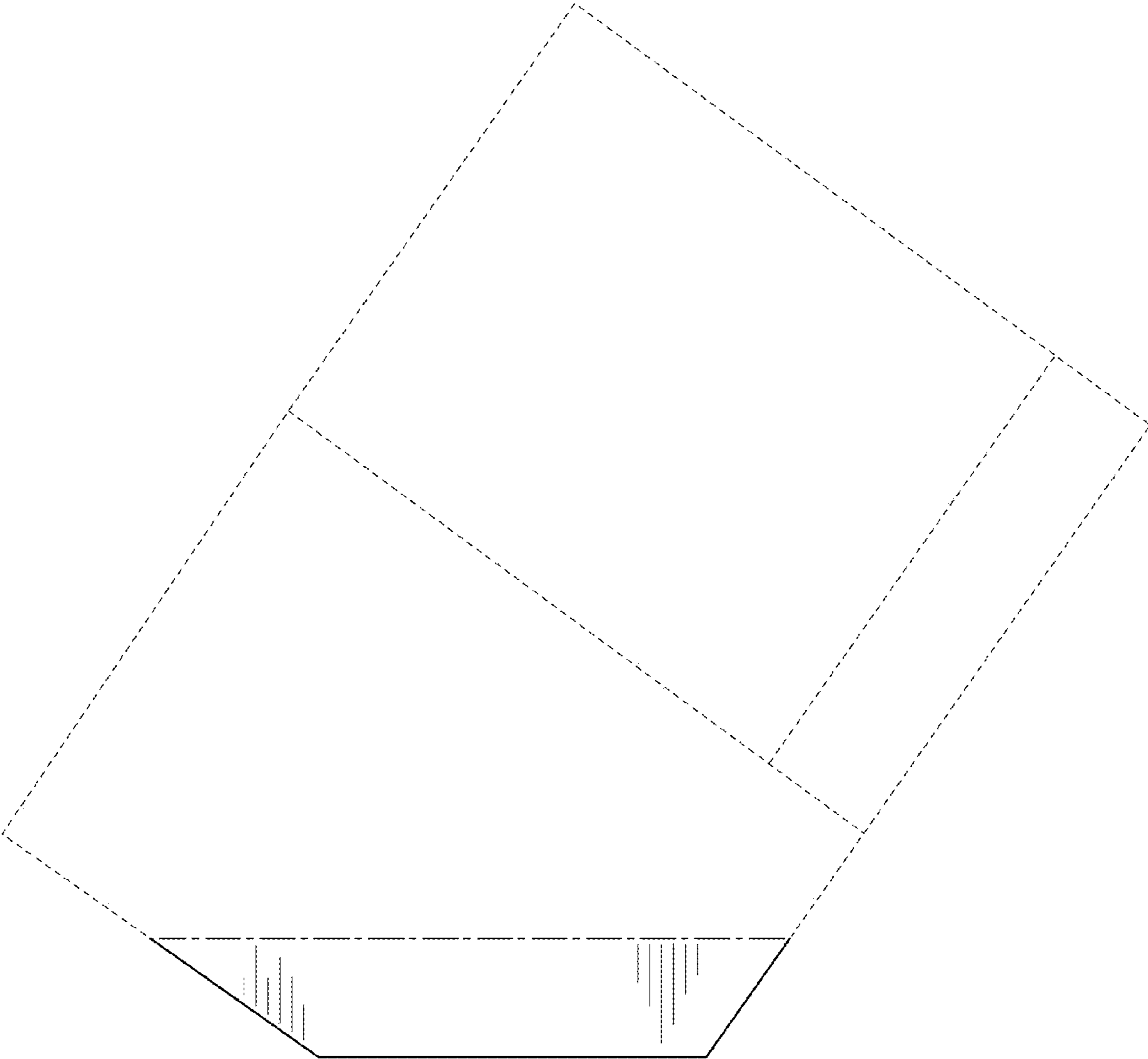

FIG. 5

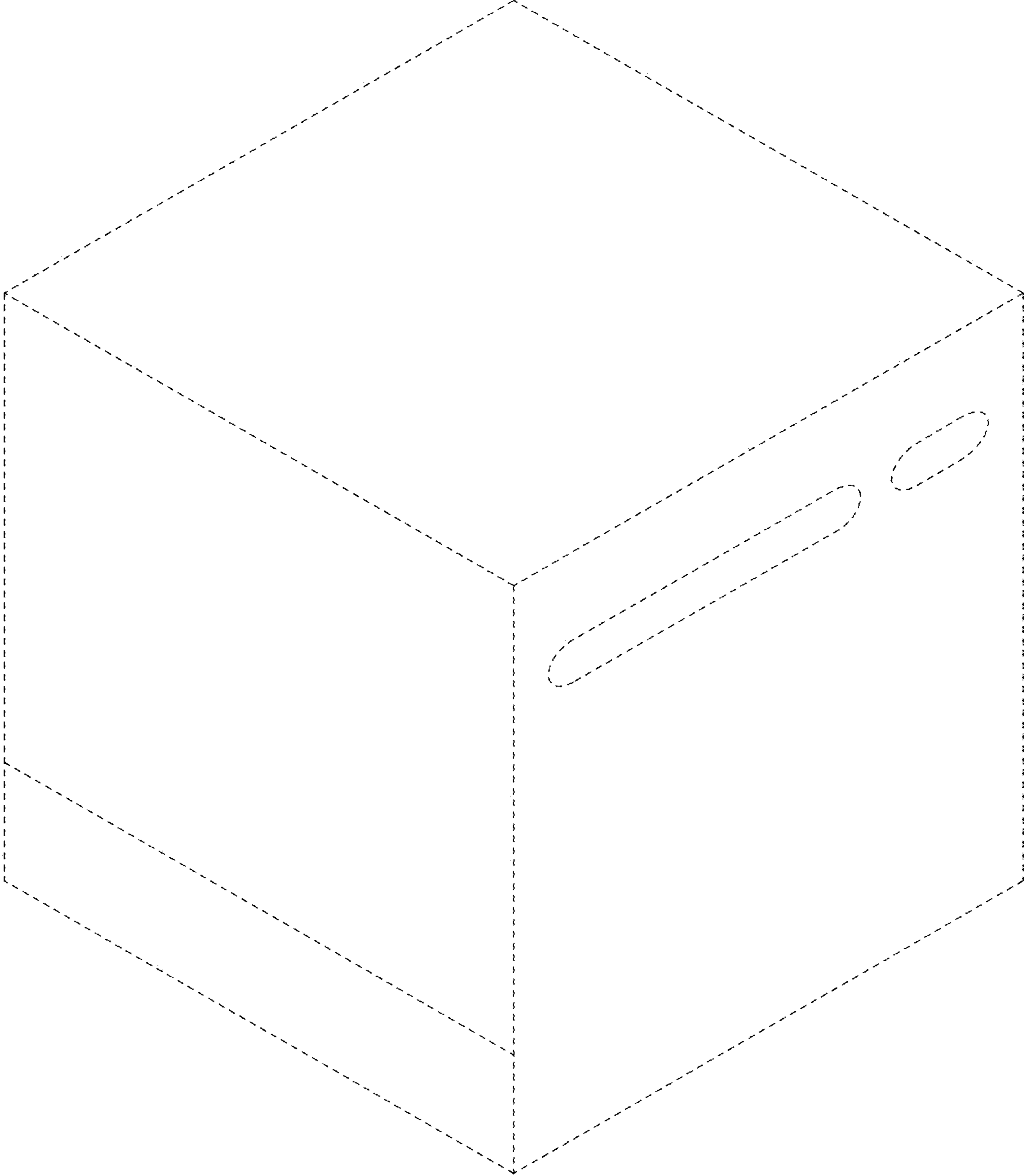

FIG. 6



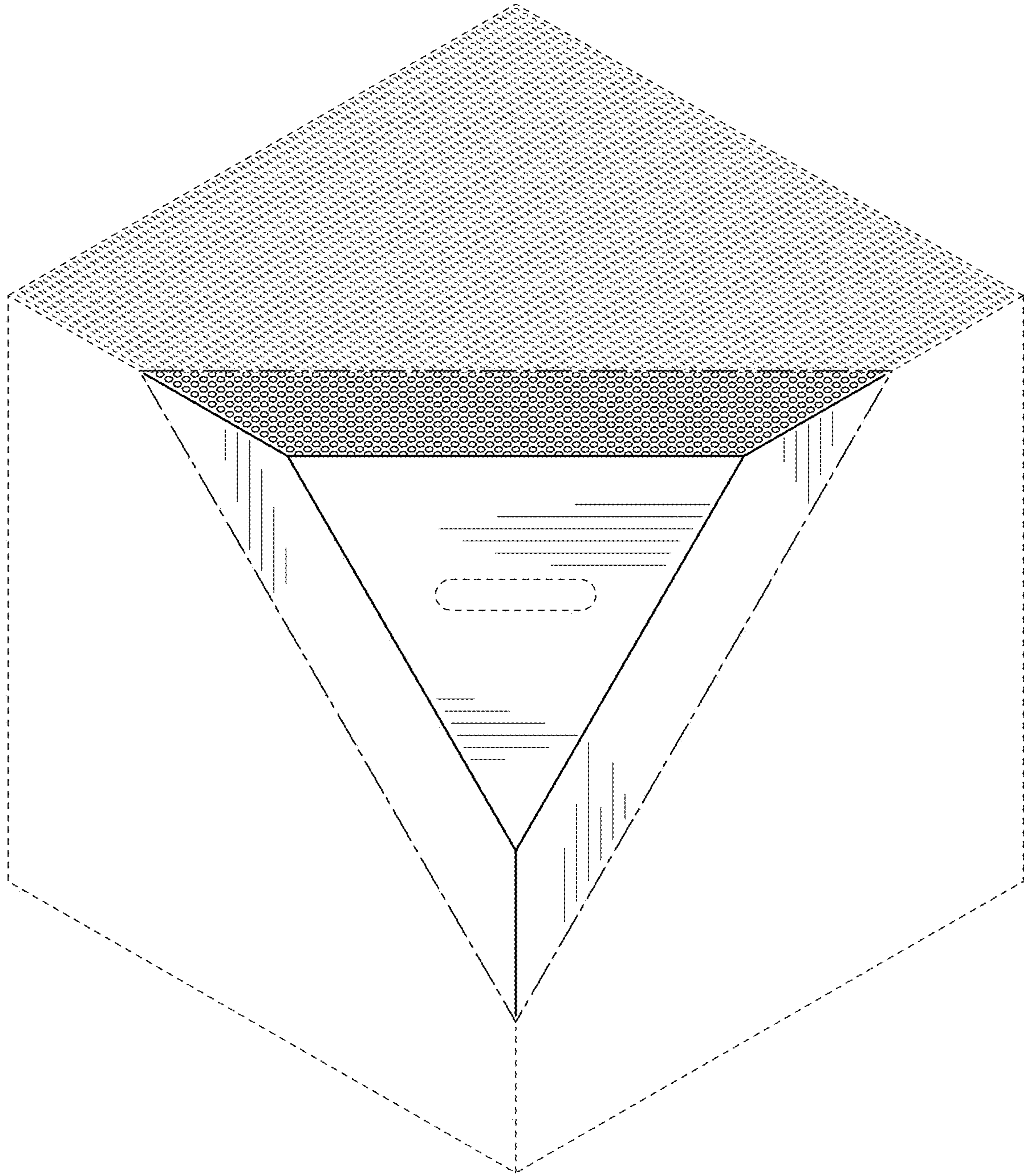

FIG. 7