



US00D937184S

(12) **United States Design Patent**
Miyazaki

(10) **Patent No.:** **US D937,184 S**

(45) **Date of Patent:** **** Nov. 30, 2021**

- (54) **TIRE**
- (71) Applicant: **Toyo Tire Corporation**, Itami (JP)
- (72) Inventor: **Tetsuji Miyazaki**, Itami (JP)
- (73) Assignee: **Toyo Tire Corporation**, Itami (JP)
- (**) Term: **15 Years**
- (21) Appl. No.: **29/728,061**
- (22) Filed: **Mar. 16, 2020**

D450,273 S *	11/2001	Guspodin	D12/579
D453,311 S *	2/2002	Guspodin	D12/579
D457,486 S *	5/2002	Guspodin	D12/579
D483,009 S *	12/2003	Rayman	D12/602
D627,709 S *	11/2010	Harvey	D12/579
D791,687 S *	7/2017	Sueyoshi	D12/579

(30) **Foreign Application Priority Data**

- Sep. 18, 2019 (JP) 2019-020845
- (51) **LOC (13) Cl.** **12-15**
- (52) **U.S. Cl.**
USPC **D12/579**
- (58) **Field of Classification Search**
USPC D12/568-605, 900
CPC Y10T 152/10027; B60C 1/0016; B60C
11/0306; B60C 11/0302; B60C 3/06;
B60C 9/17
See application file for complete search history.

FOREIGN PATENT DOCUMENTS

CN	302467021 S	6/2013
CN	303197391 S	5/2015
JP	1404133 S	12/2010

* cited by examiner

Primary Examiner — John A Voytek

(74) *Attorney, Agent, or Firm* — Sterne, Kessler, Goldstein & Fox P.L.L.C.

(57) **CLAIM**

The ornamental design for a tire, as shown and described.

DESCRIPTION

FIG. 1 is a front perspective view of a tire showing the claimed design;
 FIG. 2 is a front view thereof;
 FIG. 3 is a rear view thereof;
 FIG. 4 is a top plan view thereof, the bottom plan view being the same;
 FIG. 5 is a right side view thereof;
 FIG. 6 is a left side view thereof;
 FIG. 7 is an enlarged view taken along line 7-7 in FIG. 1;
 FIG. 8 is an enlarged view of the portion 8-8 in FIG. 2; and,
 FIG. 9 is a cross-sectional view taken along line 9-9 in FIG. 8.

In the drawings, the broken lines show portions of the tire that form no part of the claimed design.

1 Claim, 9 Drawing Sheets

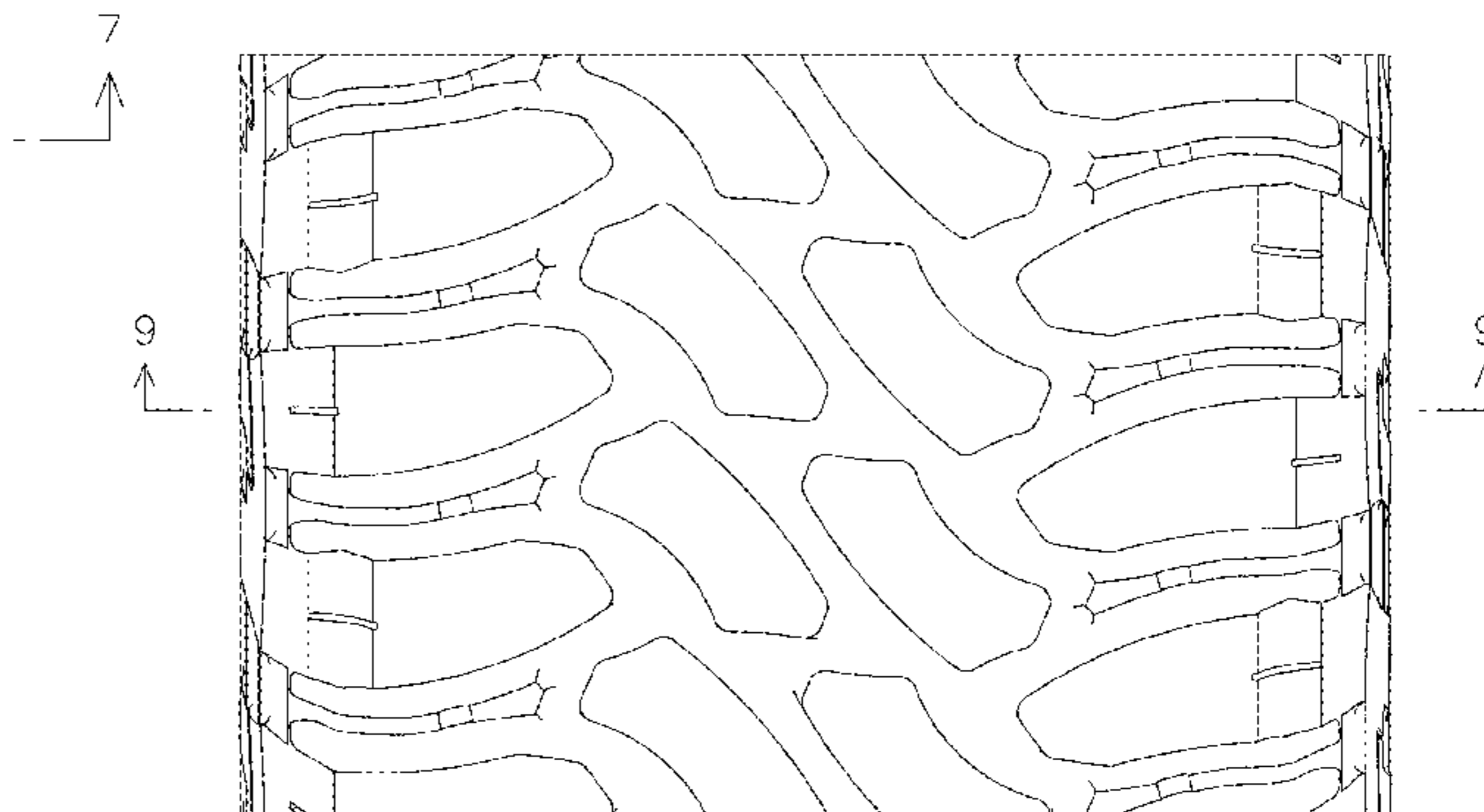
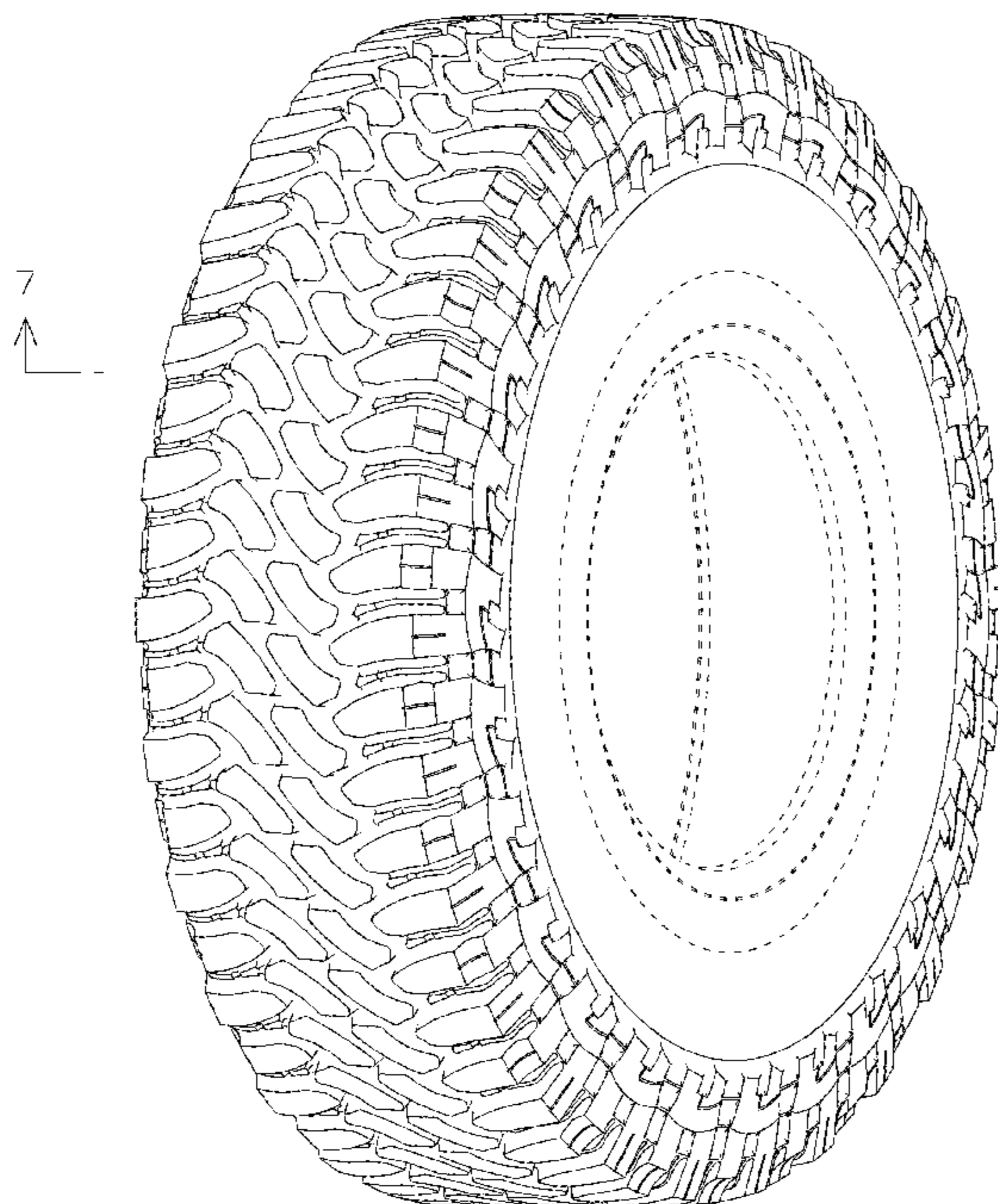

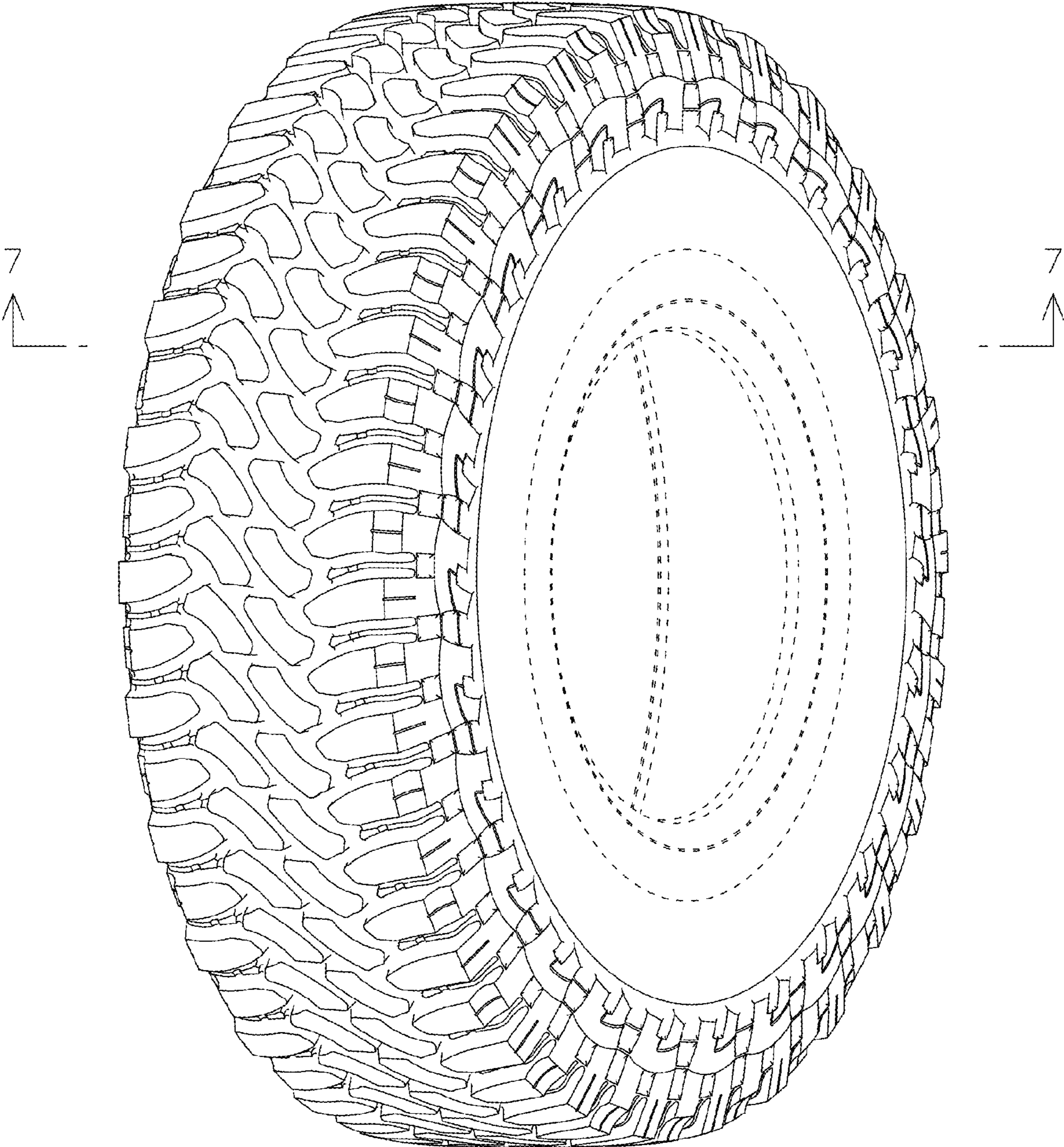

FIG. 1

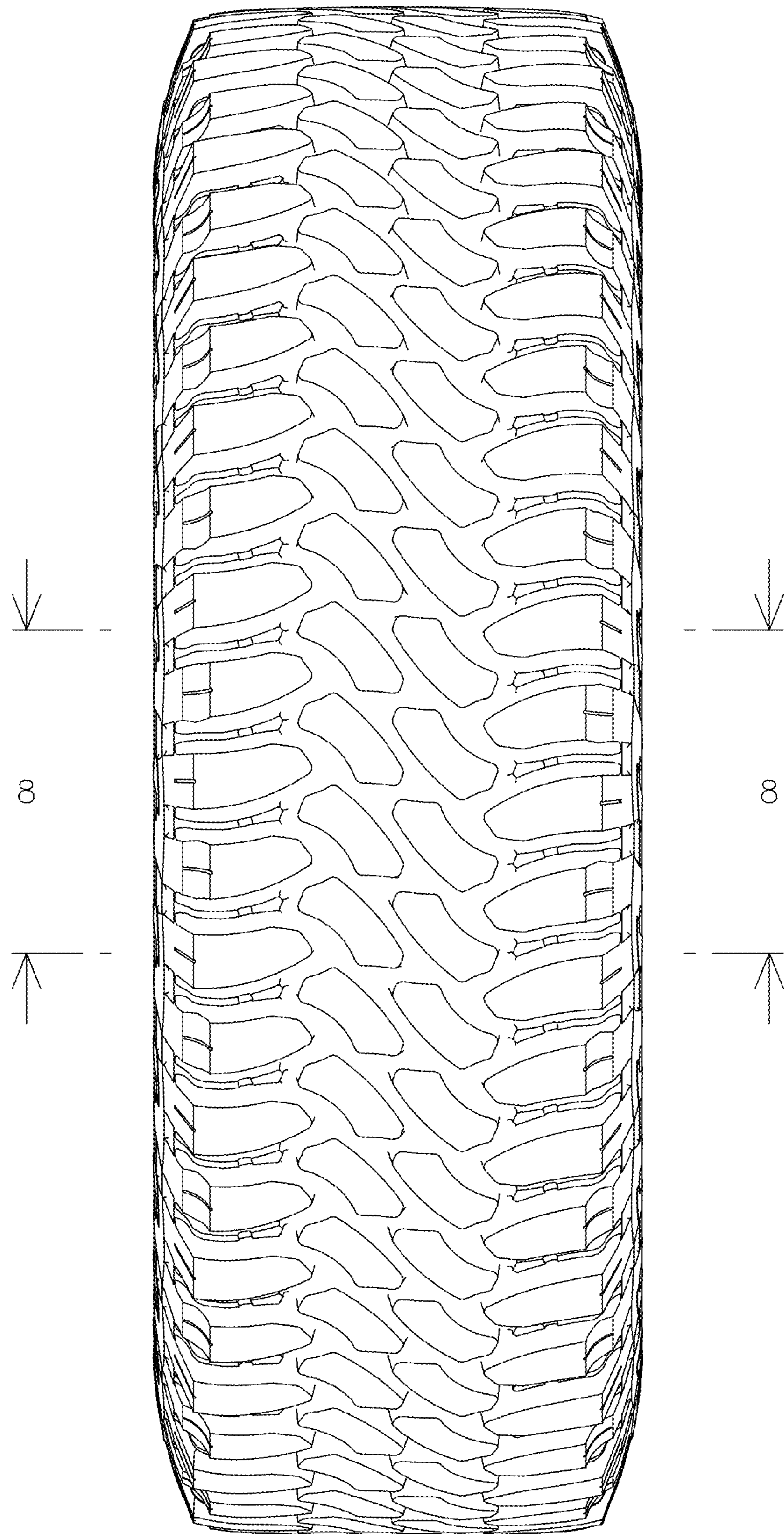

FIG. 2

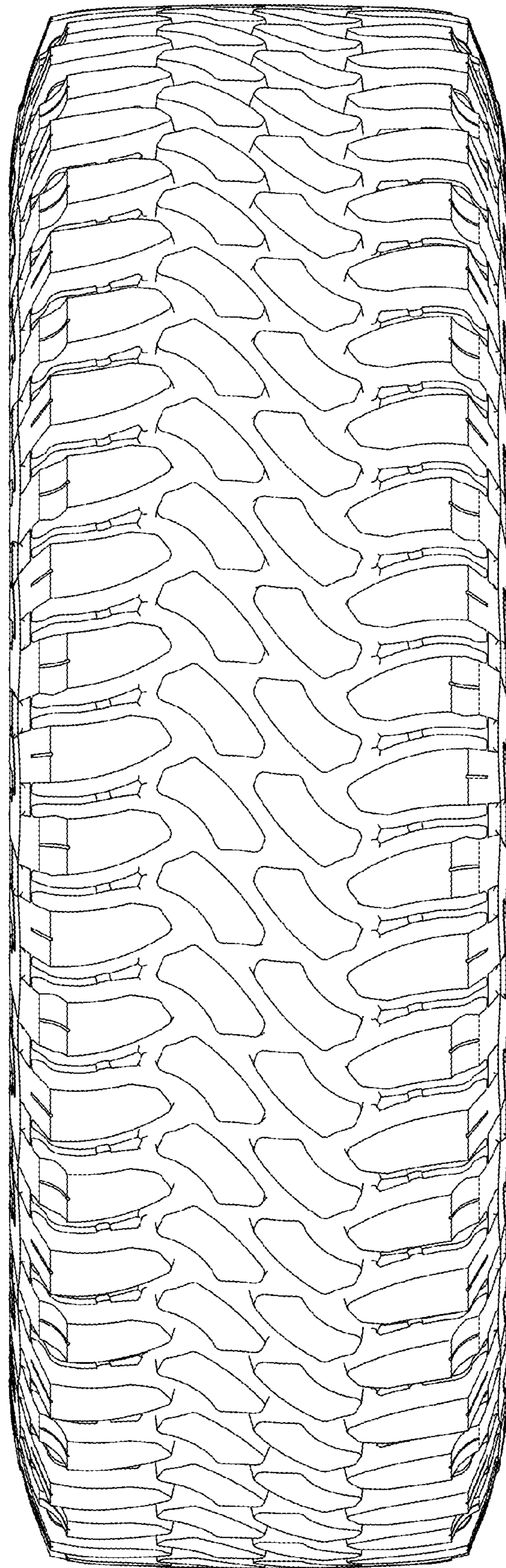

FIG. 3

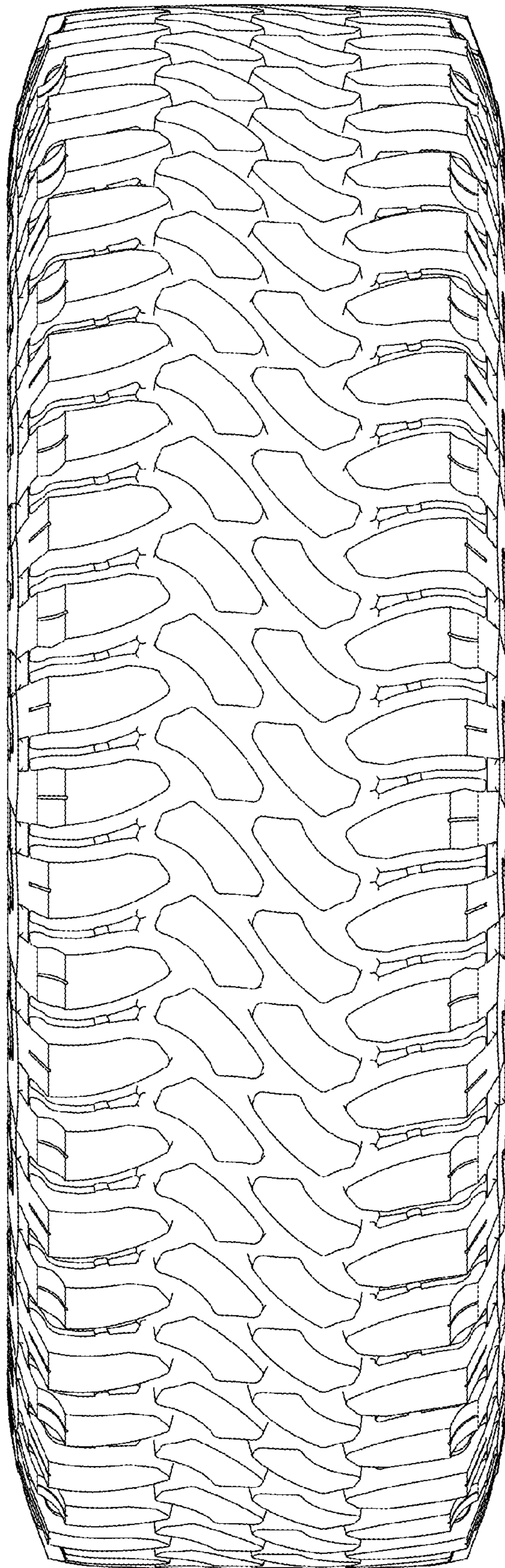

FIG. 4

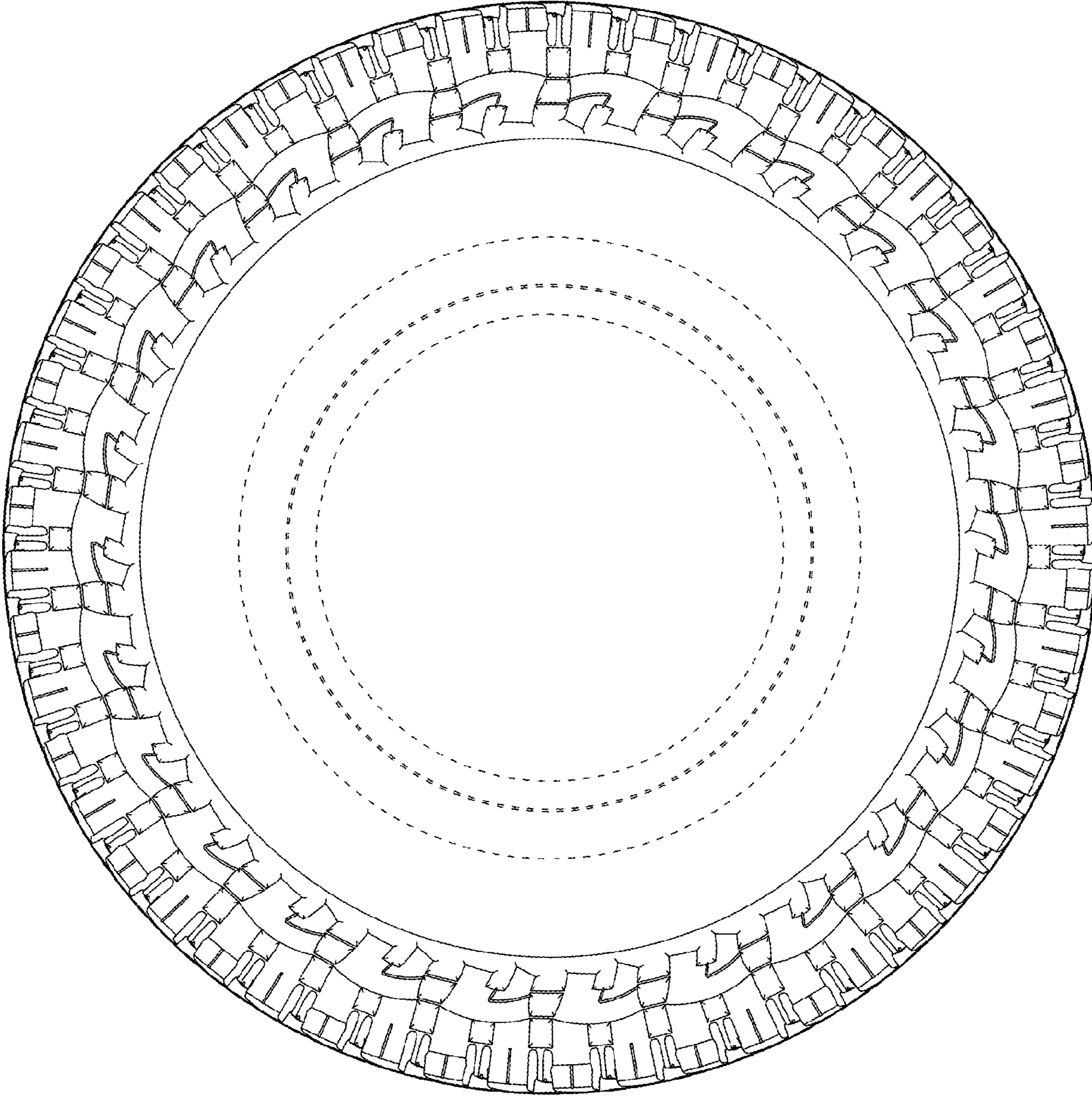

FIG. 5

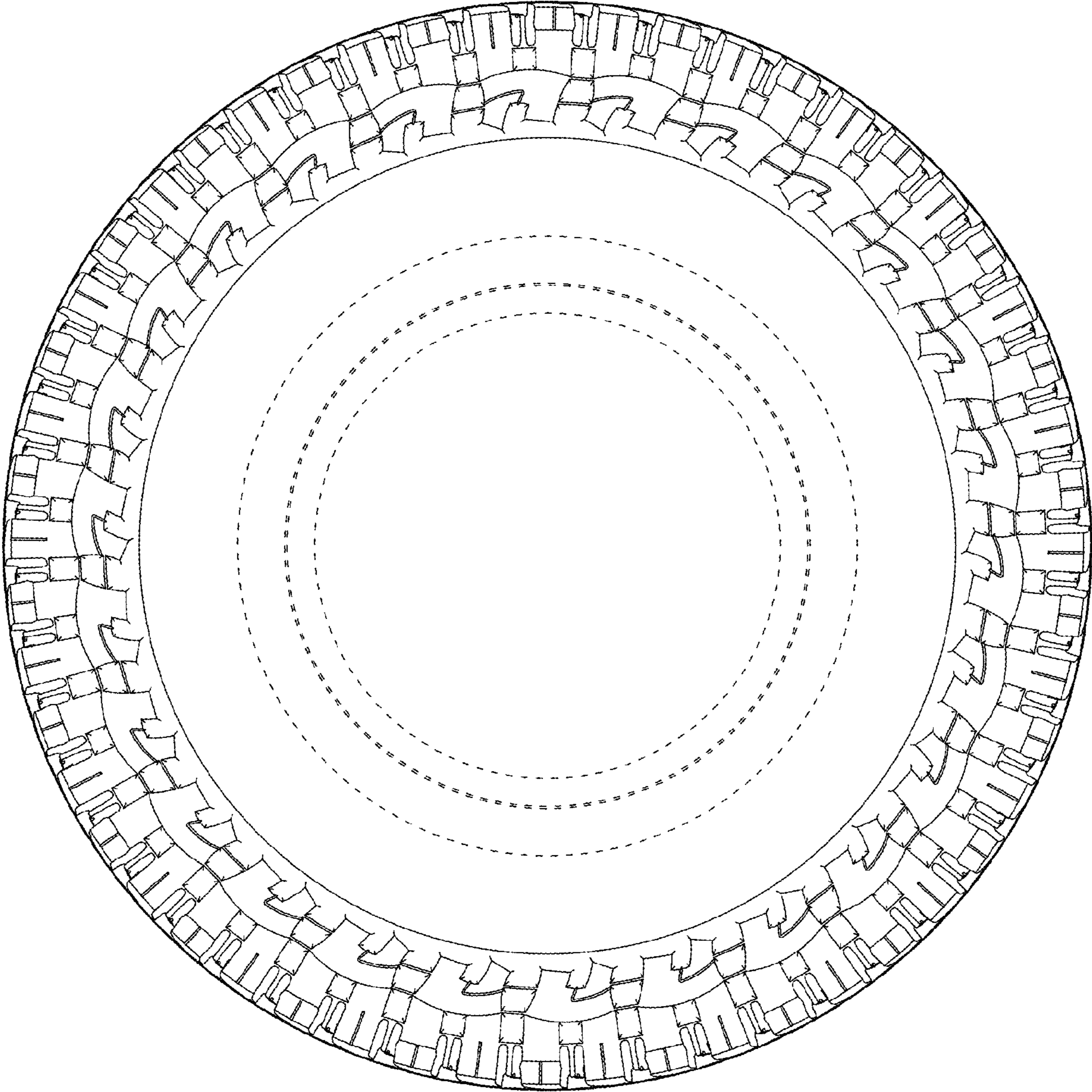

FIG. 6

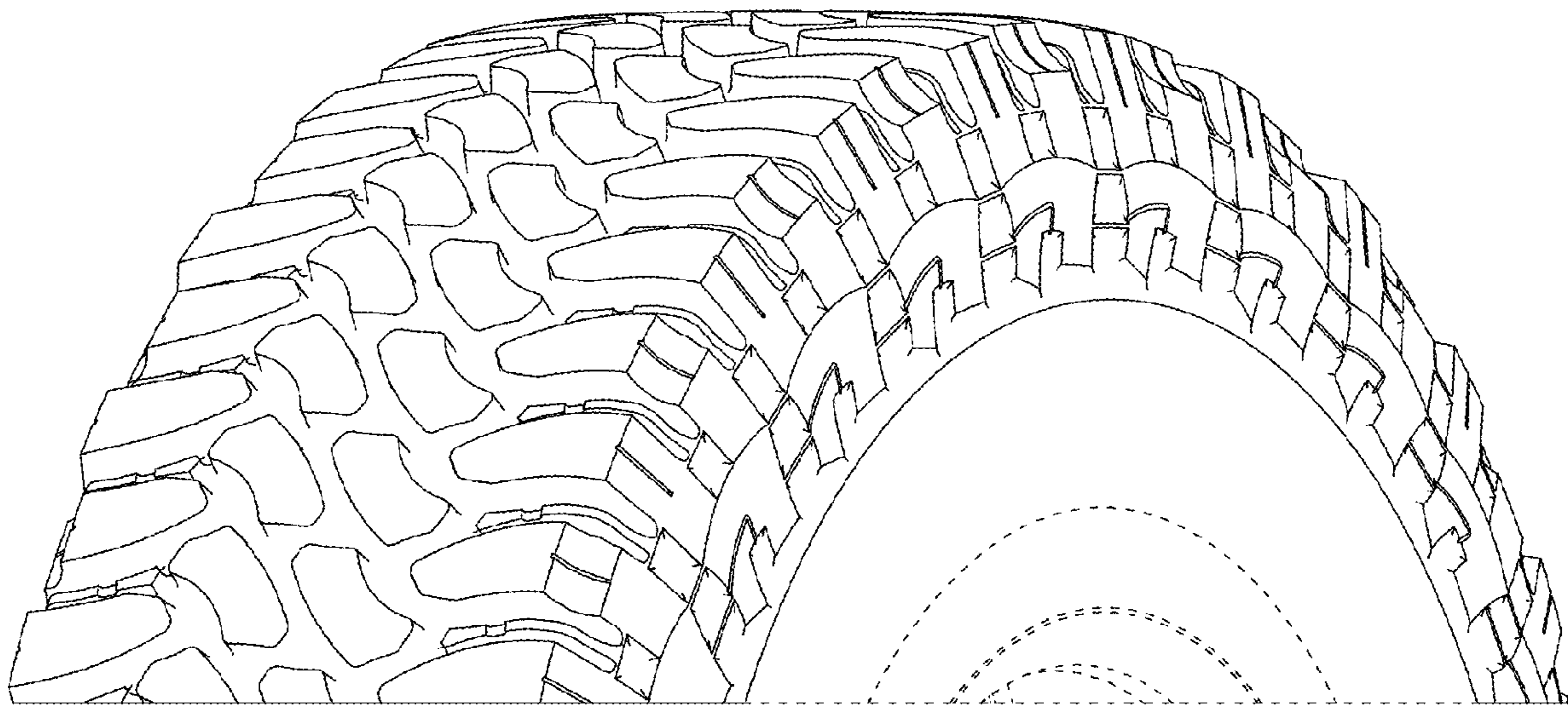

FIG. 7

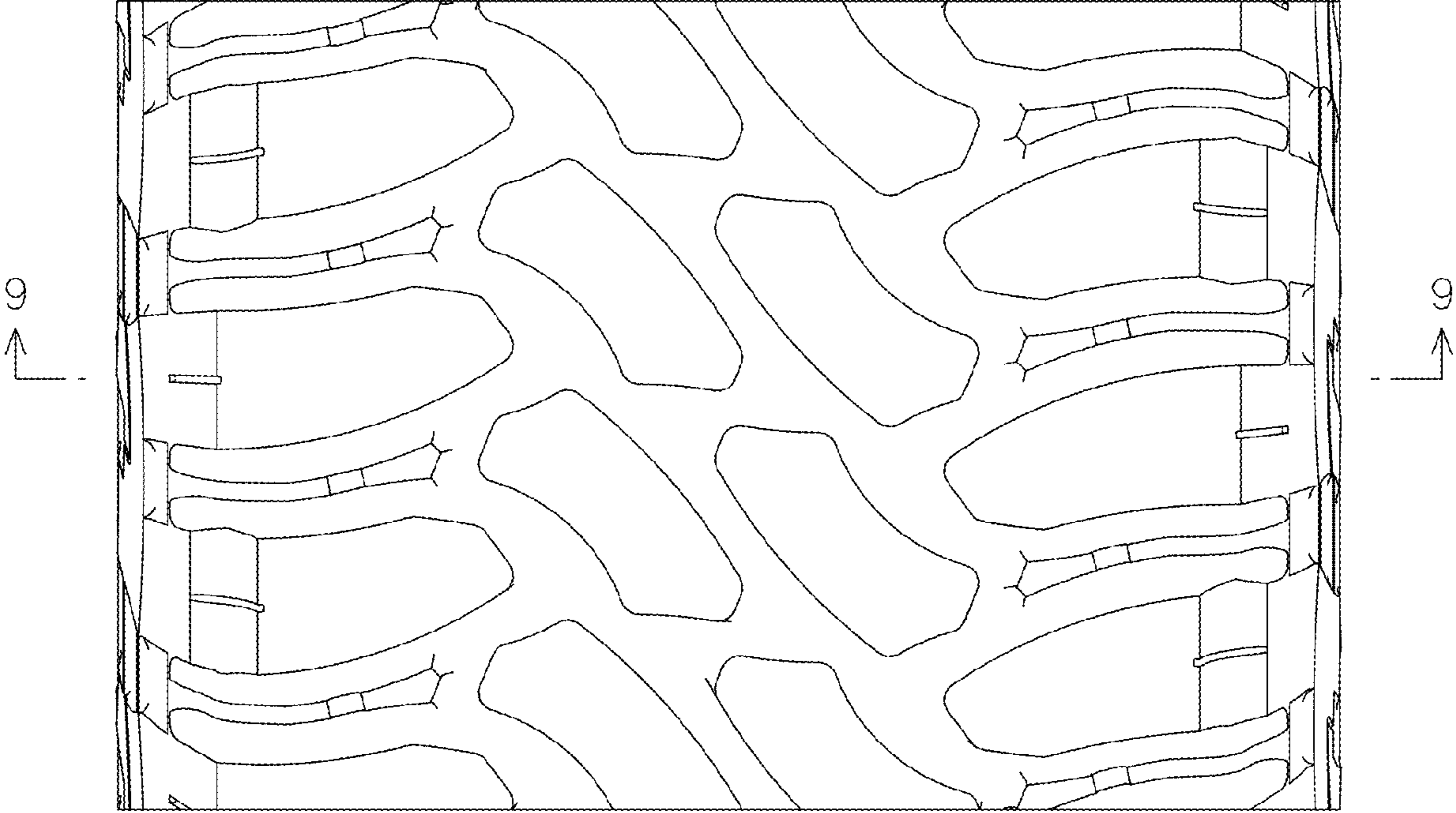

FIG. 8

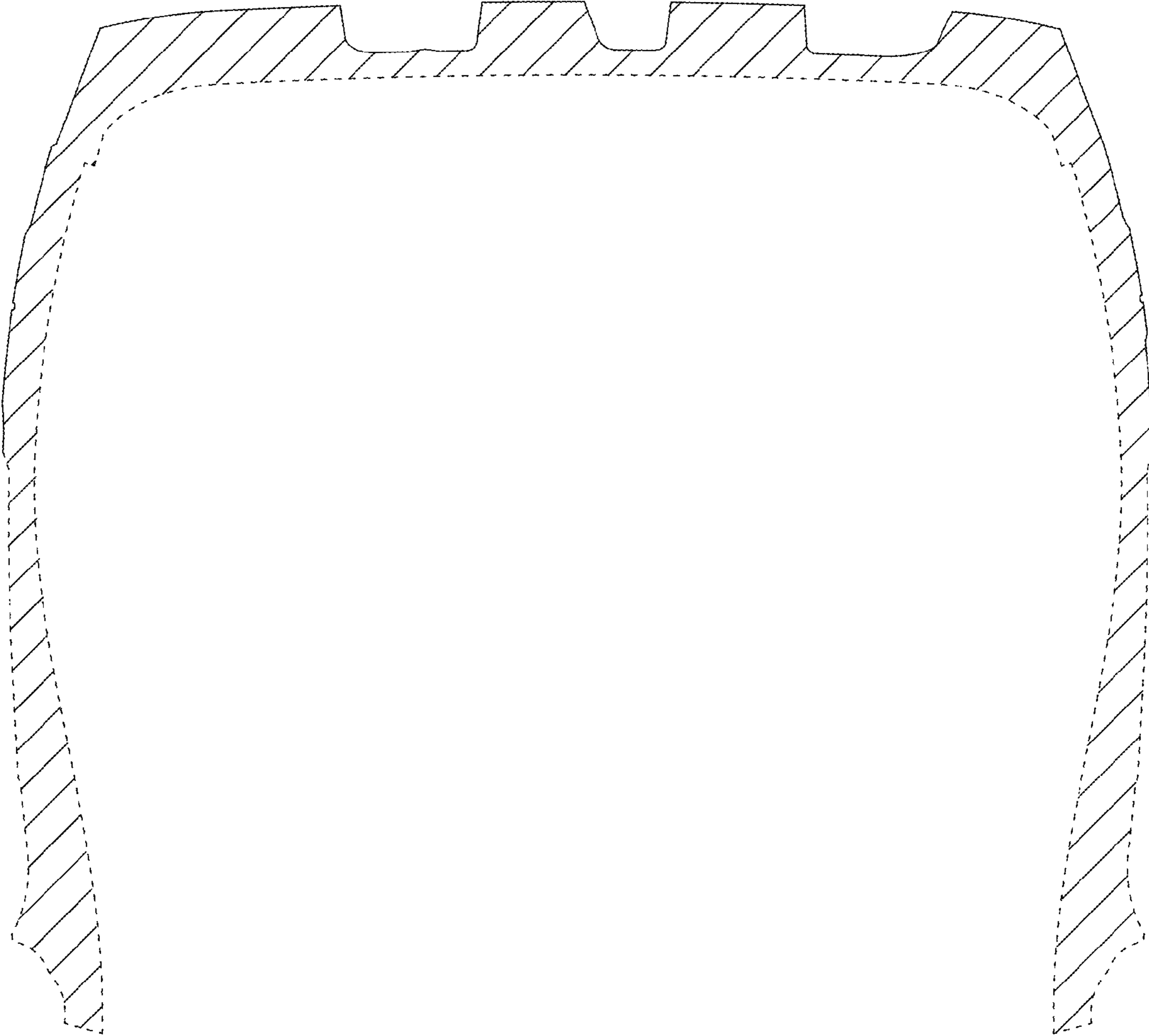

FIG. 9