



US00D937139S

(12) **United States Design Patent** (10) **Patent No.:** **US D937,139 S**
Eriksson et al. (45) **Date of Patent:** **** Nov. 30, 2021**

- (54) **STROLLER**
- (71) Applicant: **Thule Sweden AB**, Hillerstorp (SE)
- (72) Inventors: **Henrik Eriksson**, Jönköping (SE); **Daniel Britton**, Calgary (CA); **Jan Adler**, Skillingaryd (SE); **Wesley Fleming**, Calgary (CA)
- (73) Assignee: **Thule Sweden AB**, Hillerstorp (SE)
- (**) Term: **15 Years**
- (21) Appl. No.: **29/650,876**
- (22) Filed: **Jun. 11, 2018**

- D498,713 S 11/2004 Chou
 - D498,714 S 11/2004 Chou
 - 6,893,040 B2 5/2005 Hou et al.
 - 6,976,697 B2 12/2005 Britton et al.
 - D519,063 S 4/2006 Chang
- (Continued)

OTHER PUBLICATIONS

Thule.com, "Thule Chariot CX 1", <https://www.thule.com/en-us/us/strollers/multisport-trailers/thule-chariot-cx-1_-10101221>, dated Sep. 14, 2016.

Primary Examiner — Charles D Hanson
(74) *Attorney, Agent, or Firm* — Sterne, Kessler, Goldstein & Fox P.L.L.C.

Related U.S. Application Data

- (63) Continuation of application No. 29/609,270, filed on Jun. 29, 2017, now Pat. No. Des. 820,169, which is a continuation of application No. 29/565,473, filed on May 20, 2016, now Pat. No. Des. 793,914.
- (51) **LOC (13) Cl.** **12-12**
- (52) **U.S. Cl.**
USPC **D12/129**
- (58) **Field of Classification Search**
USPC D12/129
CPC B62B 7/00-04; B62B 9/00-28
See application file for complete search history.

(57) **CLAIM**

The ornamental design for a stroller, as shown and described.

DESCRIPTION

FIG. 1 is a top front perspective view of a stroller showing the claimed design;
FIG. 2 is a front view thereof;
FIG. 3 is a rear view thereof;
FIG. 4 is a left side view thereof;
FIG. 5 is a right side view thereof;
FIG. 6 is a top view thereof;
FIG. 7 is a bottom view thereof;
FIG. 8 is a top front perspective view of a stroller showing the claimed design;
FIG. 9 is a front view thereof;
FIG. 10 is a rear view thereof;
FIG. 11 is a left side view thereof;
FIG. 12 is a right side view thereof;
FIG. 13 is a top view thereof; and,
FIG. 14 is a bottom view thereof.
The broken lines in the figures show portions of the stroller that form no part of the claimed design.

(56) **References Cited**

U.S. PATENT DOCUMENTS

- 5,267,744 A 12/1993 Berry et al.
- 5,421,597 A 6/1995 Berner
- D371,094 S 6/1996 Hinkston
- D408,768 S 4/1999 Baechler et al.
- D442,895 S 5/2001 Chiu
- D452,195 S 12/2001 Baechler
- 6,402,166 B1 6/2002 Chiu
- D475,951 S 6/2003 Everett
- D481,976 S 11/2003 Everett
- 6,671,926 B2 1/2004 Huang

1 Claim, 14 Drawing Sheets

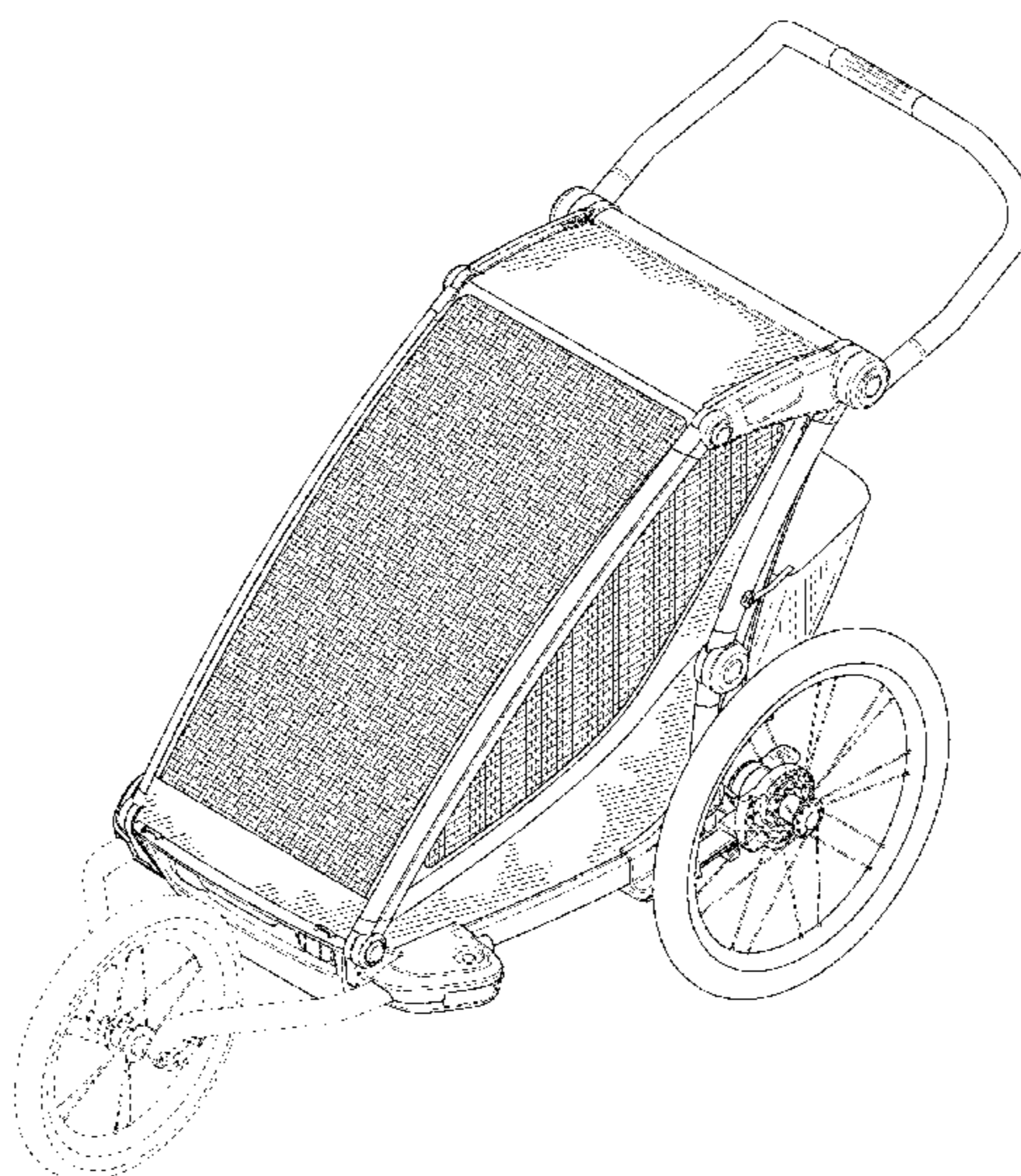

(56)

References Cited

U.S. PATENT DOCUMENTS

7,150,499	B2	12/2006	McGregor	
7,547,029	B2	6/2009	Britton et al.	
D622,640	S	8/2010	Gower et al.	
D641,293	S *	7/2011	Tsai	D12/129
D687,352	S	8/2013	Shellenberger et al.	
8,695,992	B2 *	4/2014	Piaget	B62B 5/0079 280/1.5
D704,600	S	5/2014	Britton et al.	
D723,746	S	3/2015	Jakubowski et al.	
D724,501	S	3/2015	Reinius et al.	
9,050,989	B2	6/2015	Fleming et al.	
9,315,206	B2 *	4/2016	Fleming	B62B 9/28
D773,344	S *	12/2016	Tsai	D12/129
D793,914	S	8/2017	Eriksson et al.	
D811,950	S	3/2018	Hanson et al.	
9,908,552	B2 *	3/2018	Fleming	B62B 7/10
D820,169	S *	6/2018	Eriksson	D12/133
10,442,452	B2 *	10/2019	Fleming	B62B 7/126
D882,184	S *	4/2020	Jakubowski	D30/109
10,667,489	B2 *	6/2020	Jakubowski	B62B 9/142
2002/0074764	A1 *	6/2002	Allen	B62K 27/003 280/204
2008/0143076	A1 *	6/2008	Klevana	B62B 7/062 280/402
2010/0244405	A1	9/2010	Assaf	

* cited by examiner

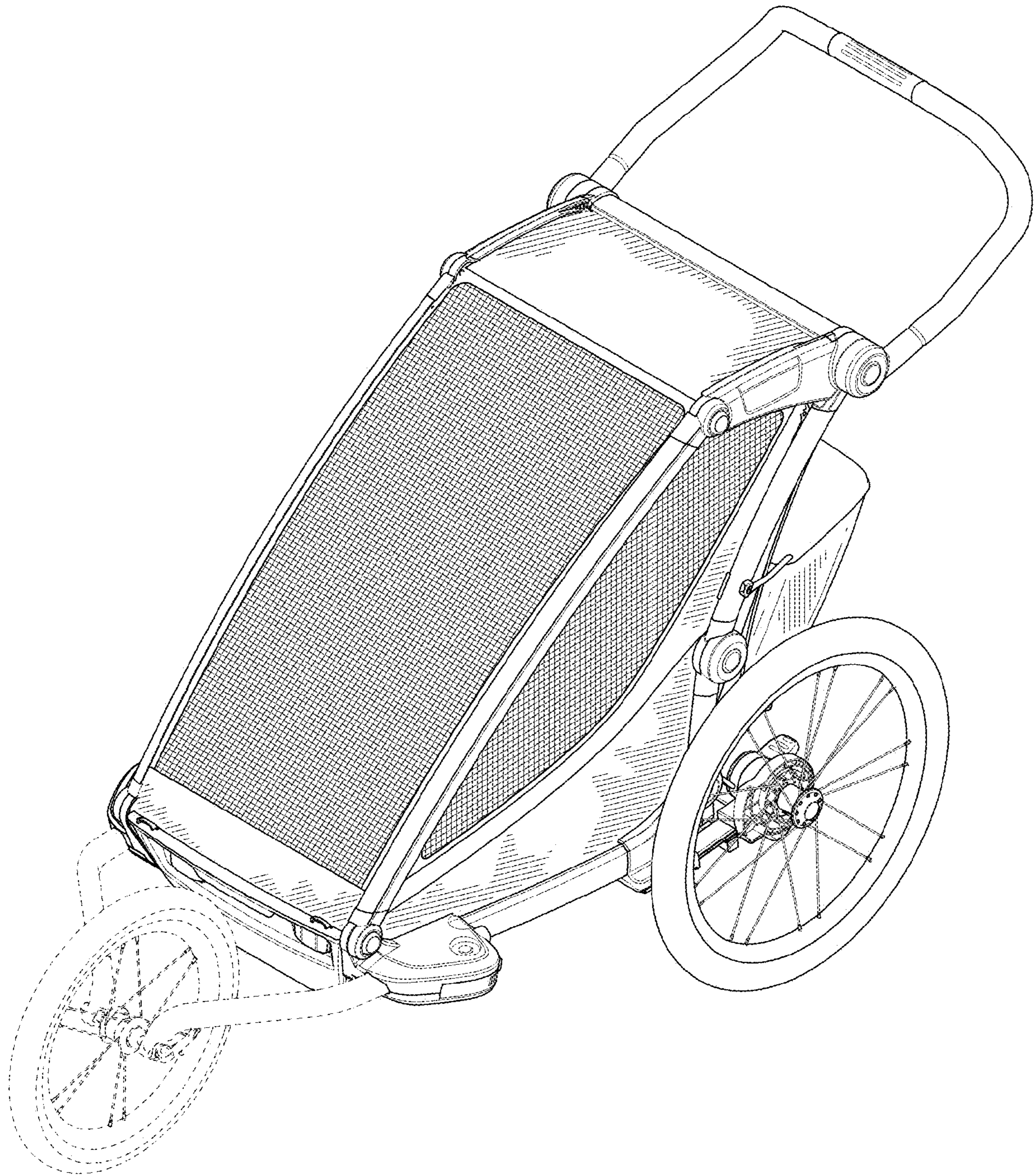

FIG. 1

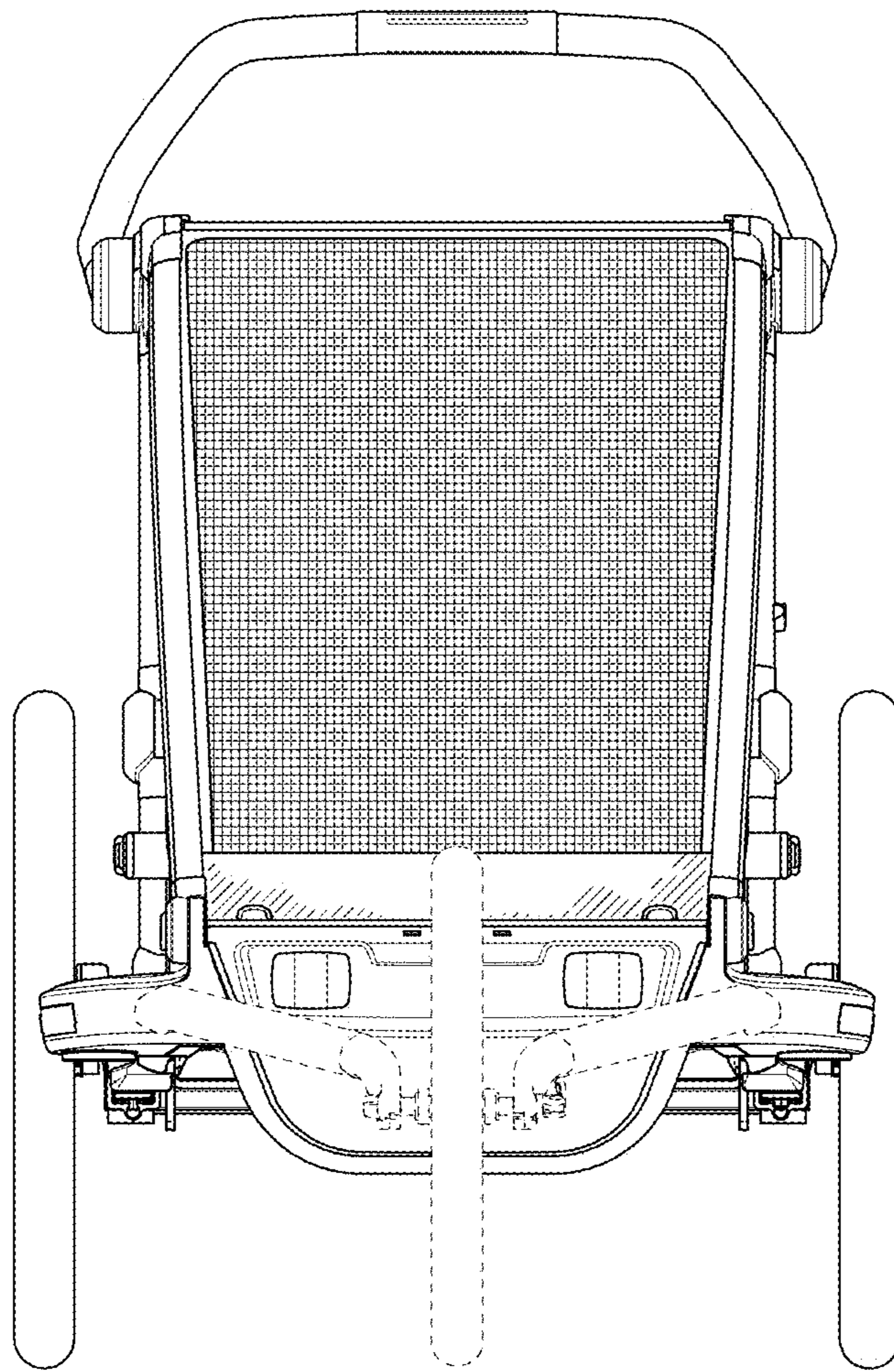

FIG. 2

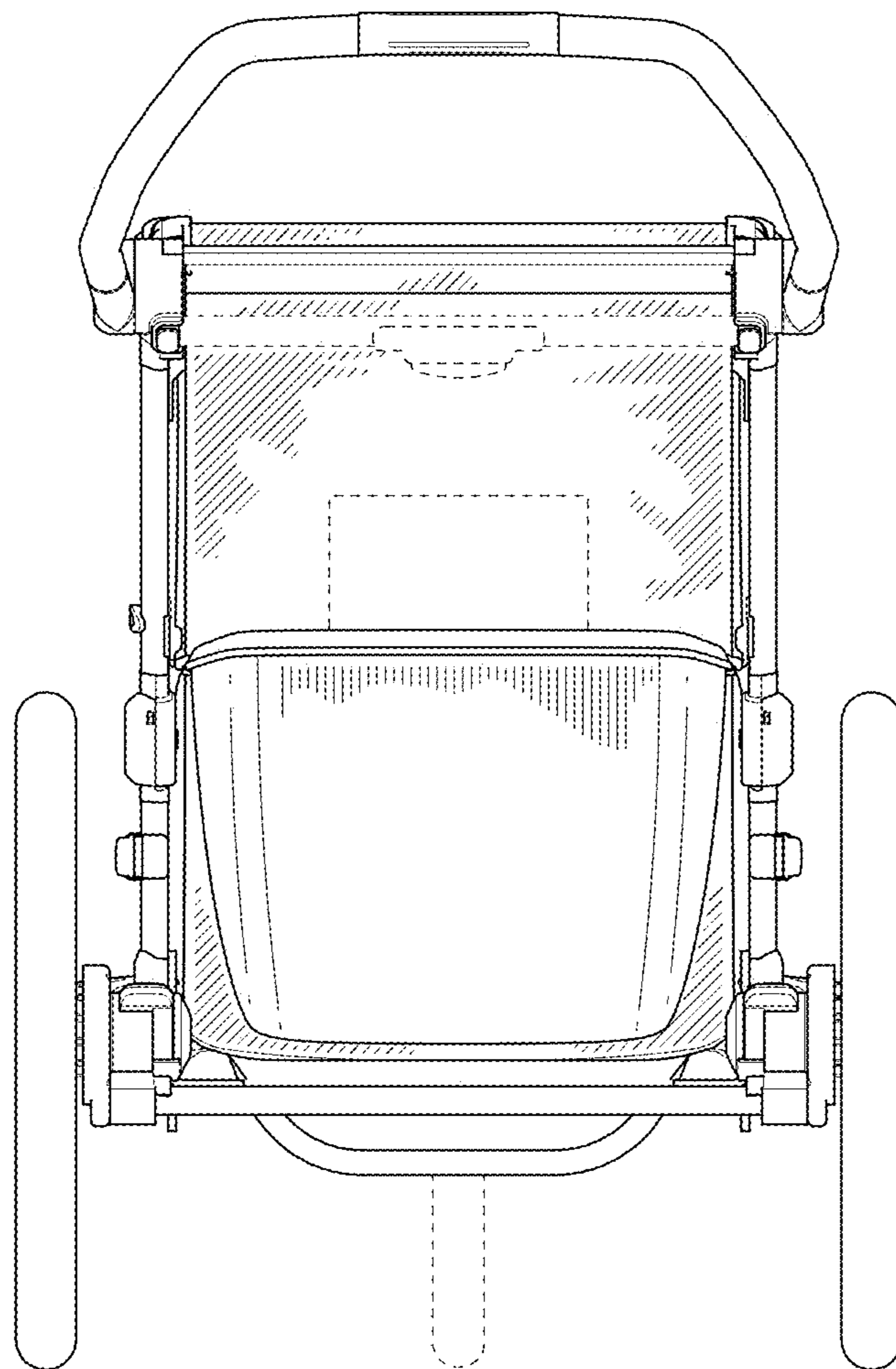

FIG. 3

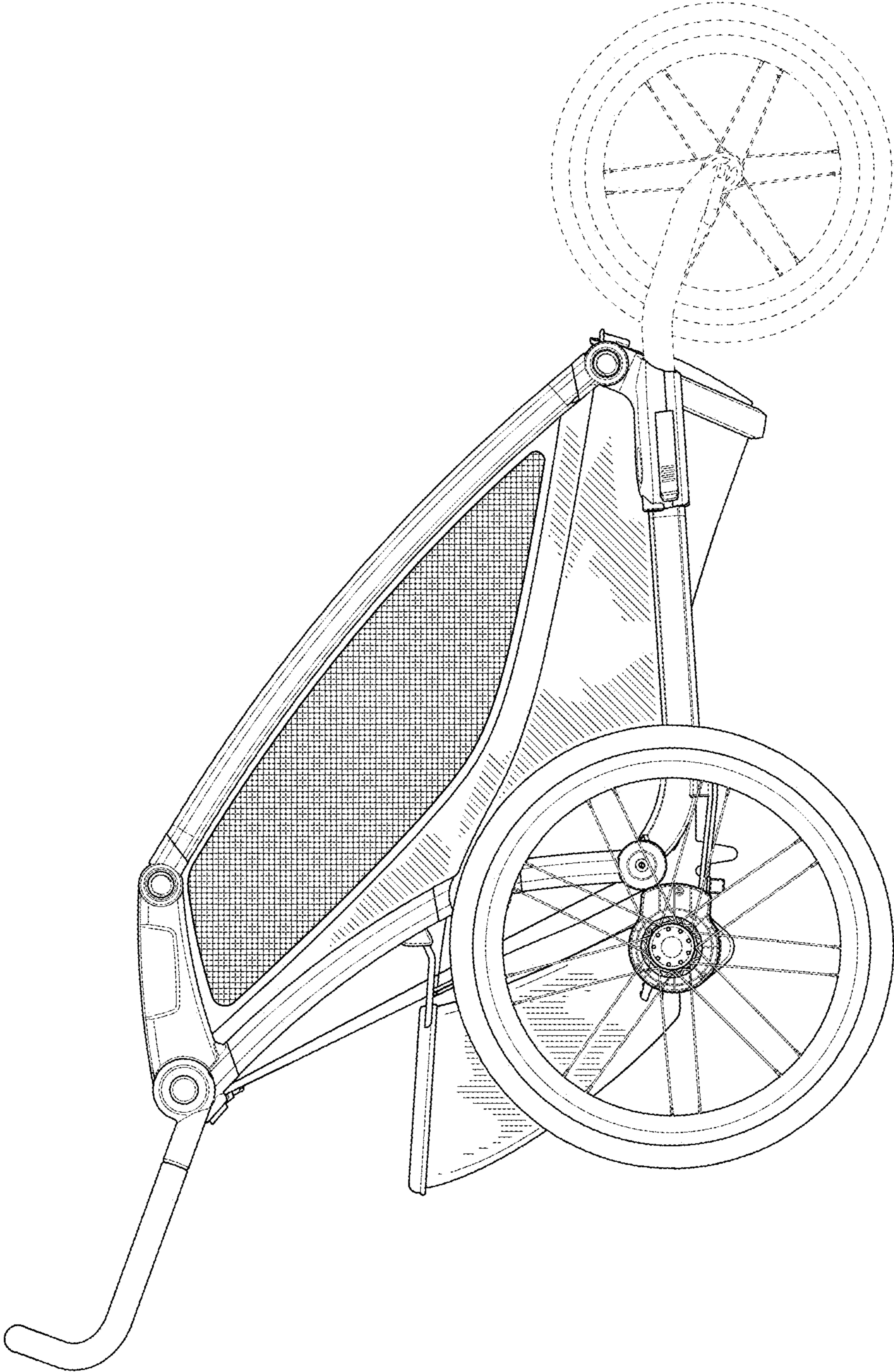

FIG. 4

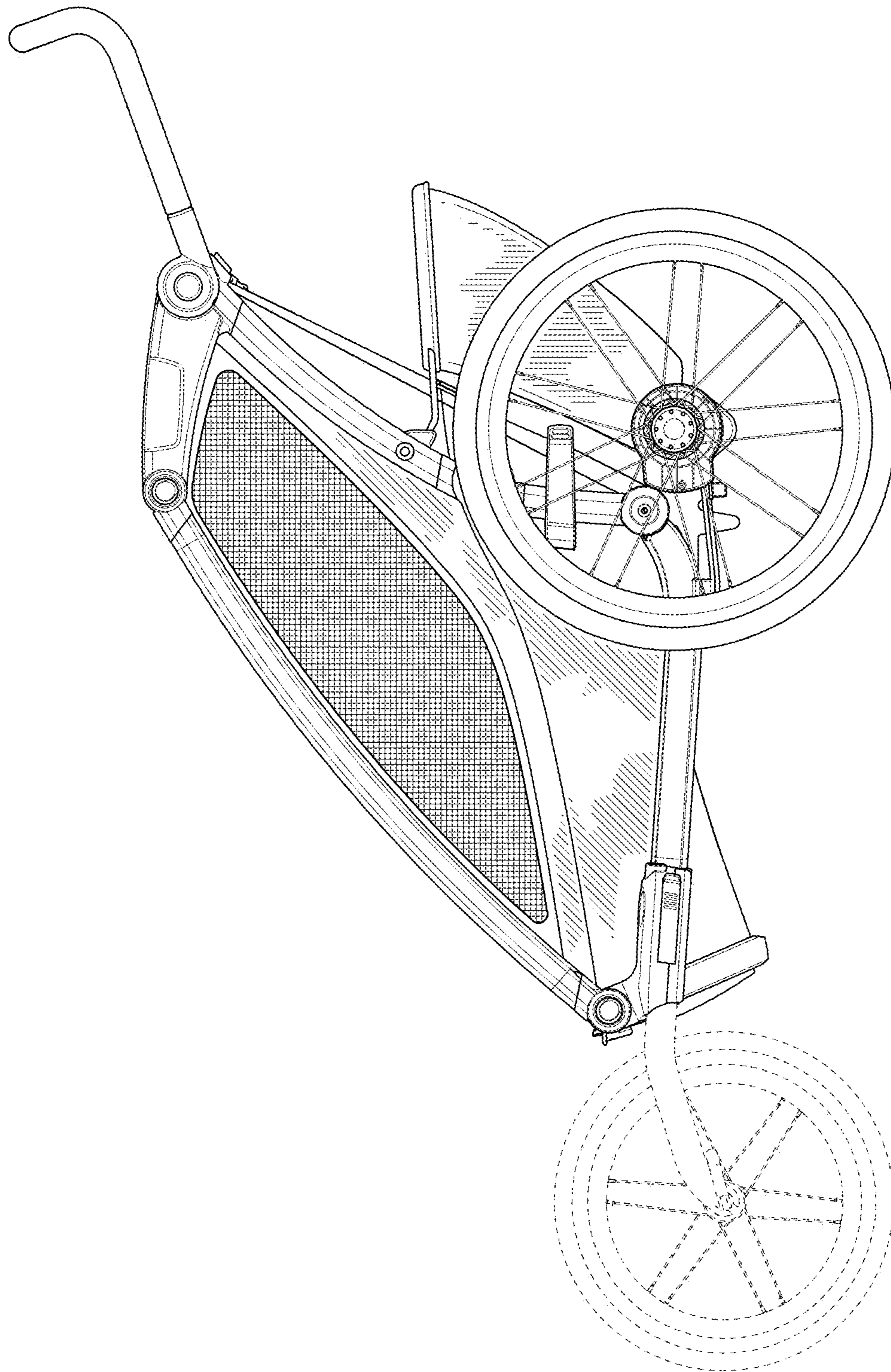

FIG. 5

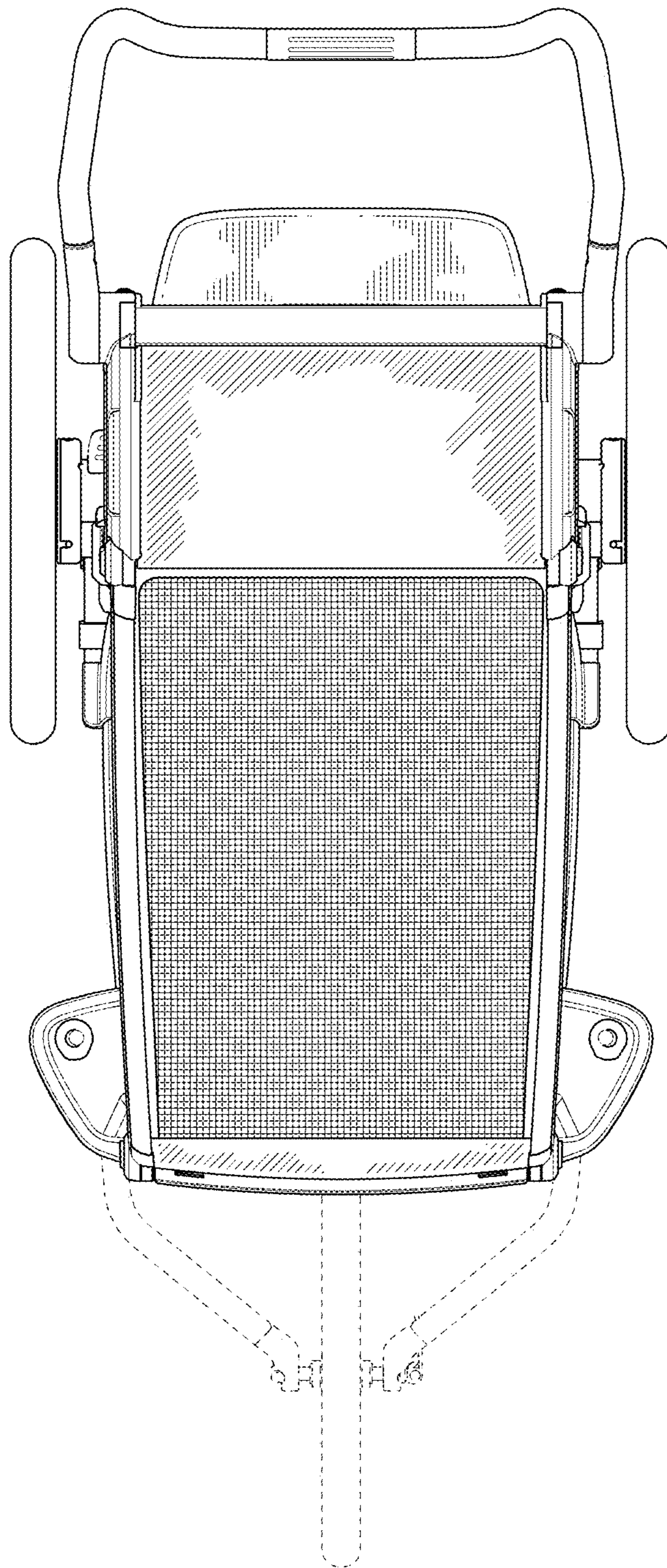

FIG. 6

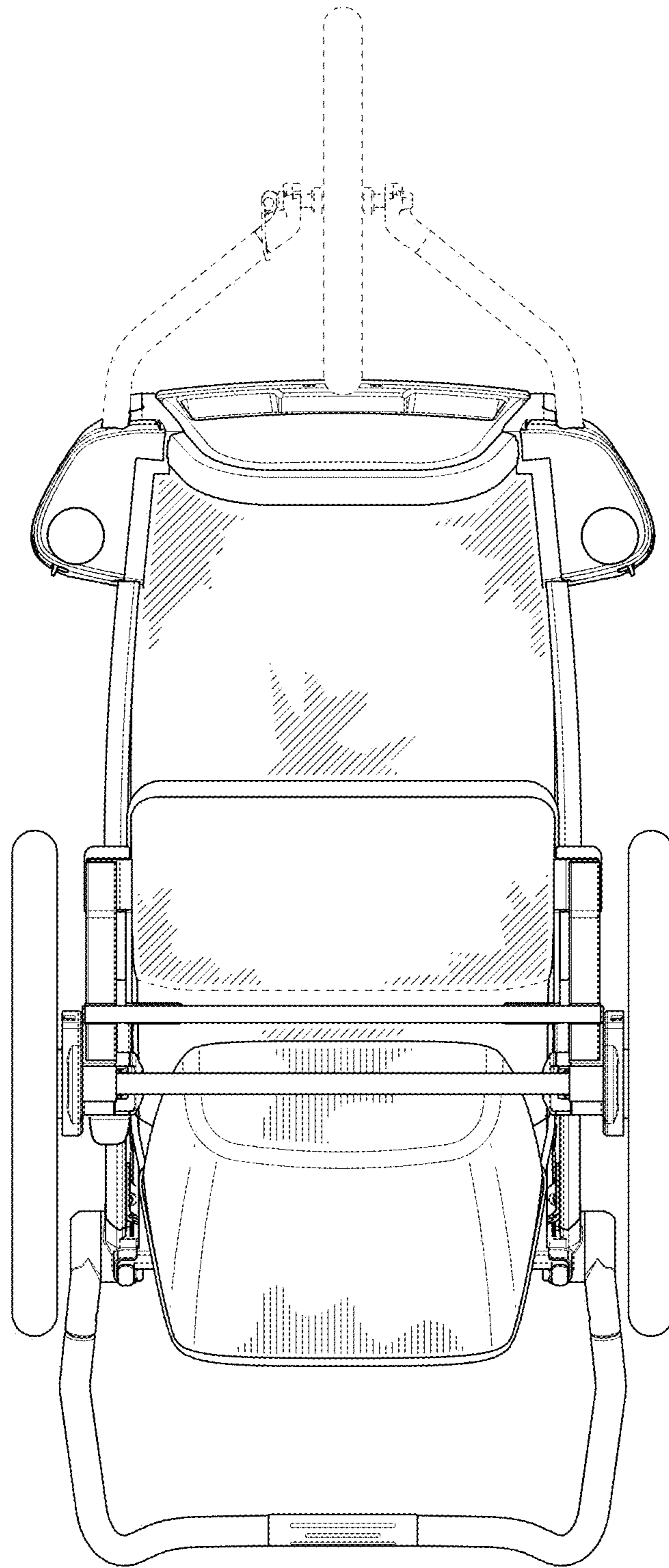

FIG. 7



FIG. 8

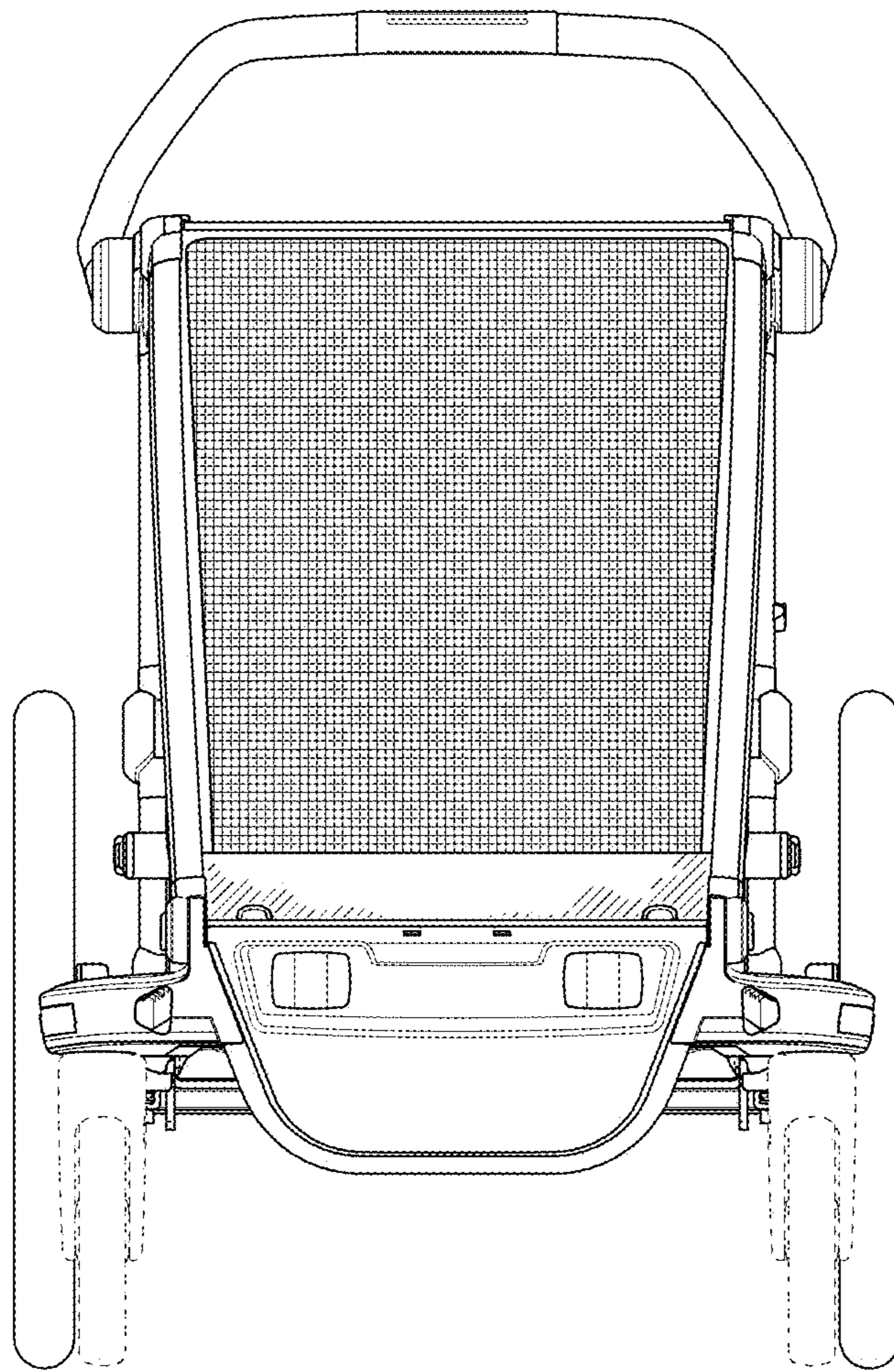

FIG. 9

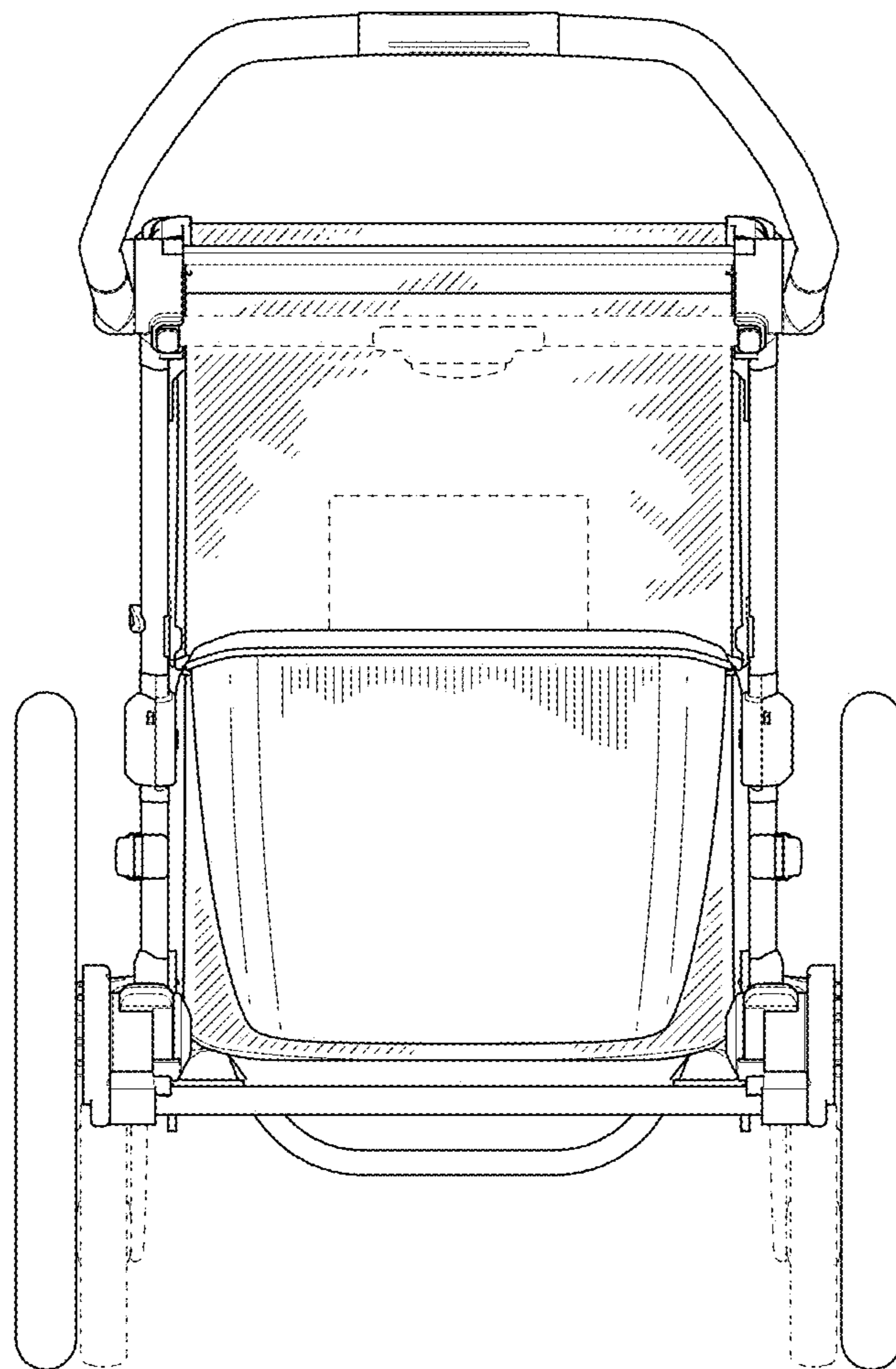

FIG. 10

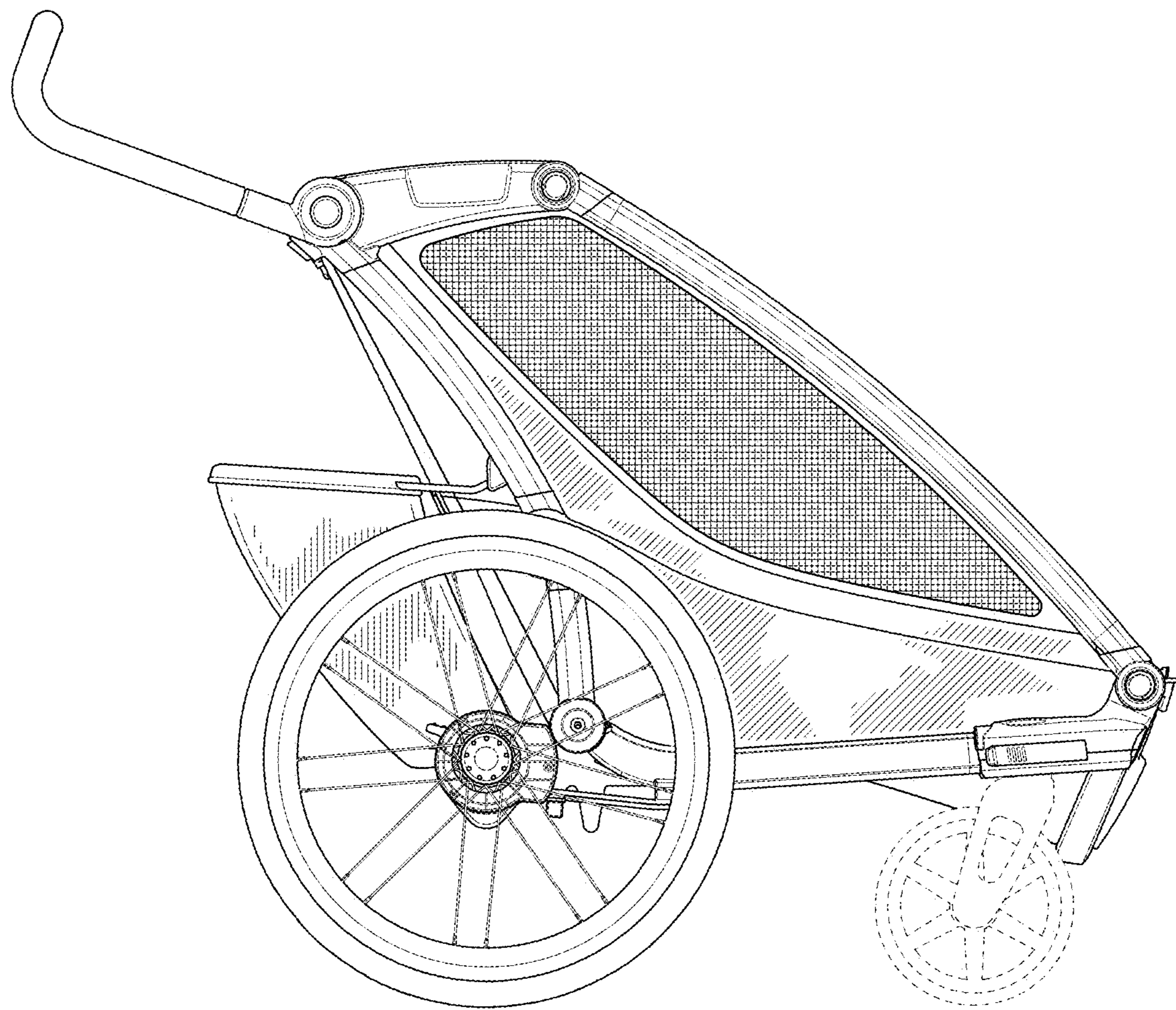

FIG. 11

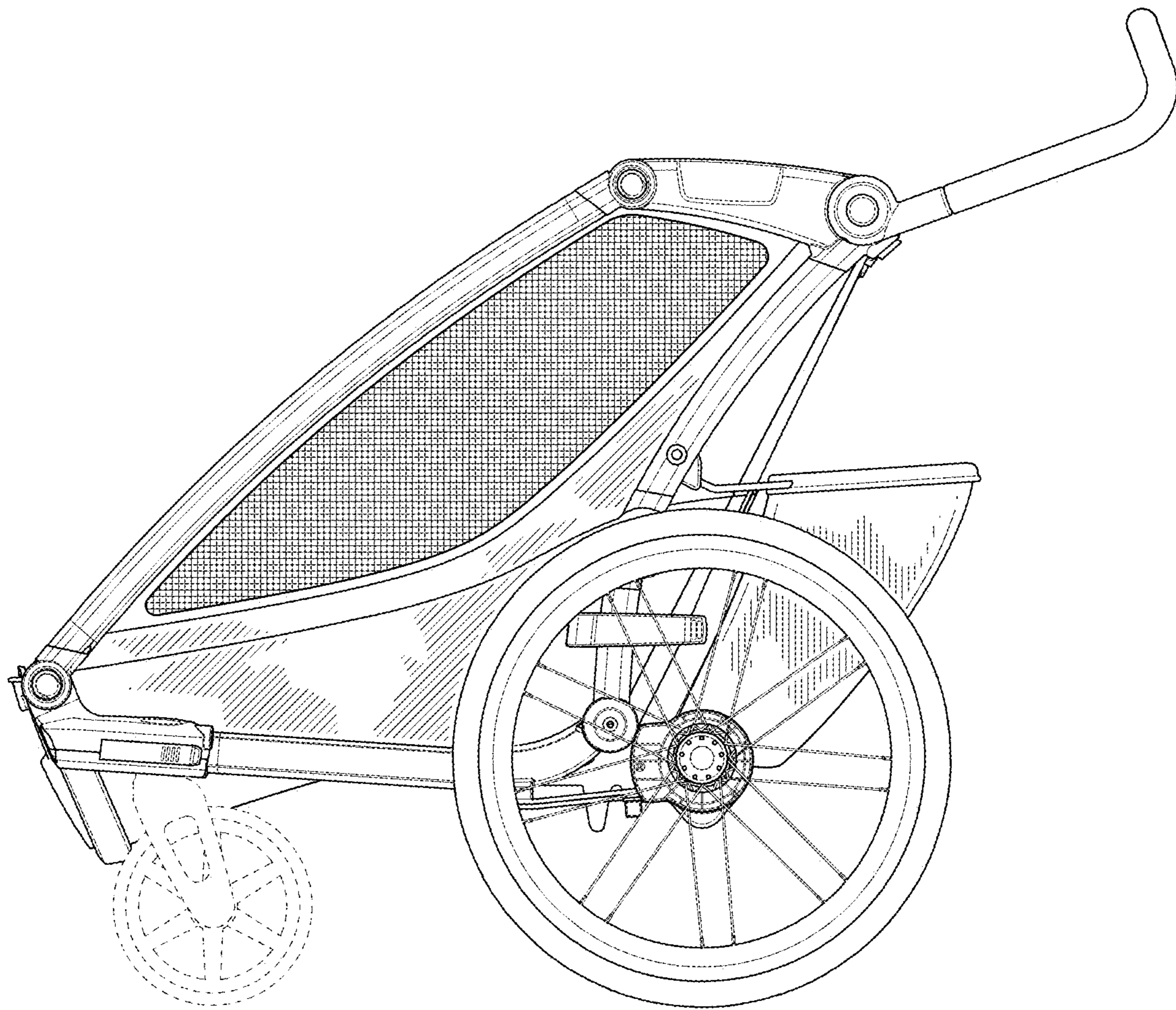

FIG. 12

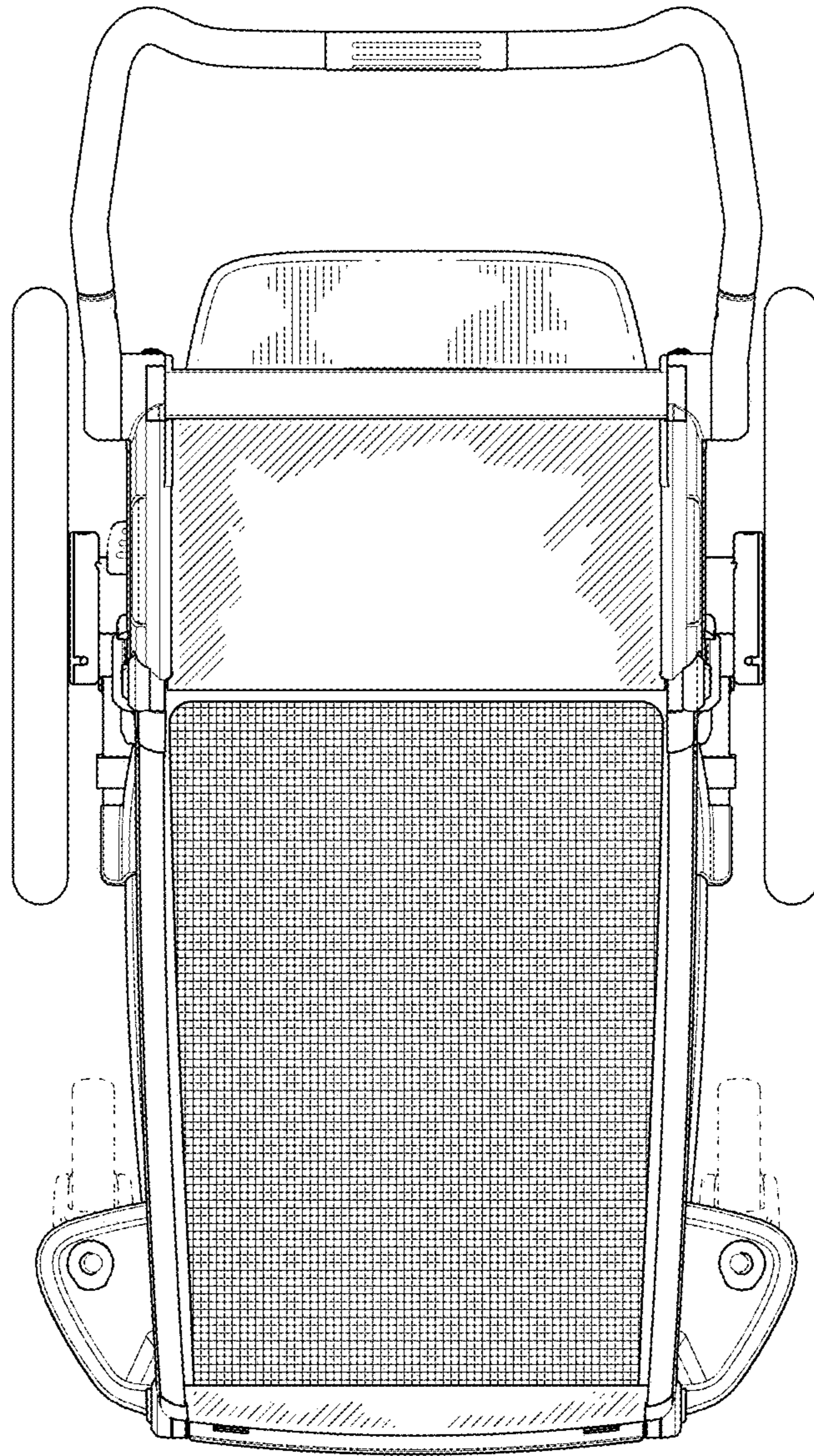

FIG. 13

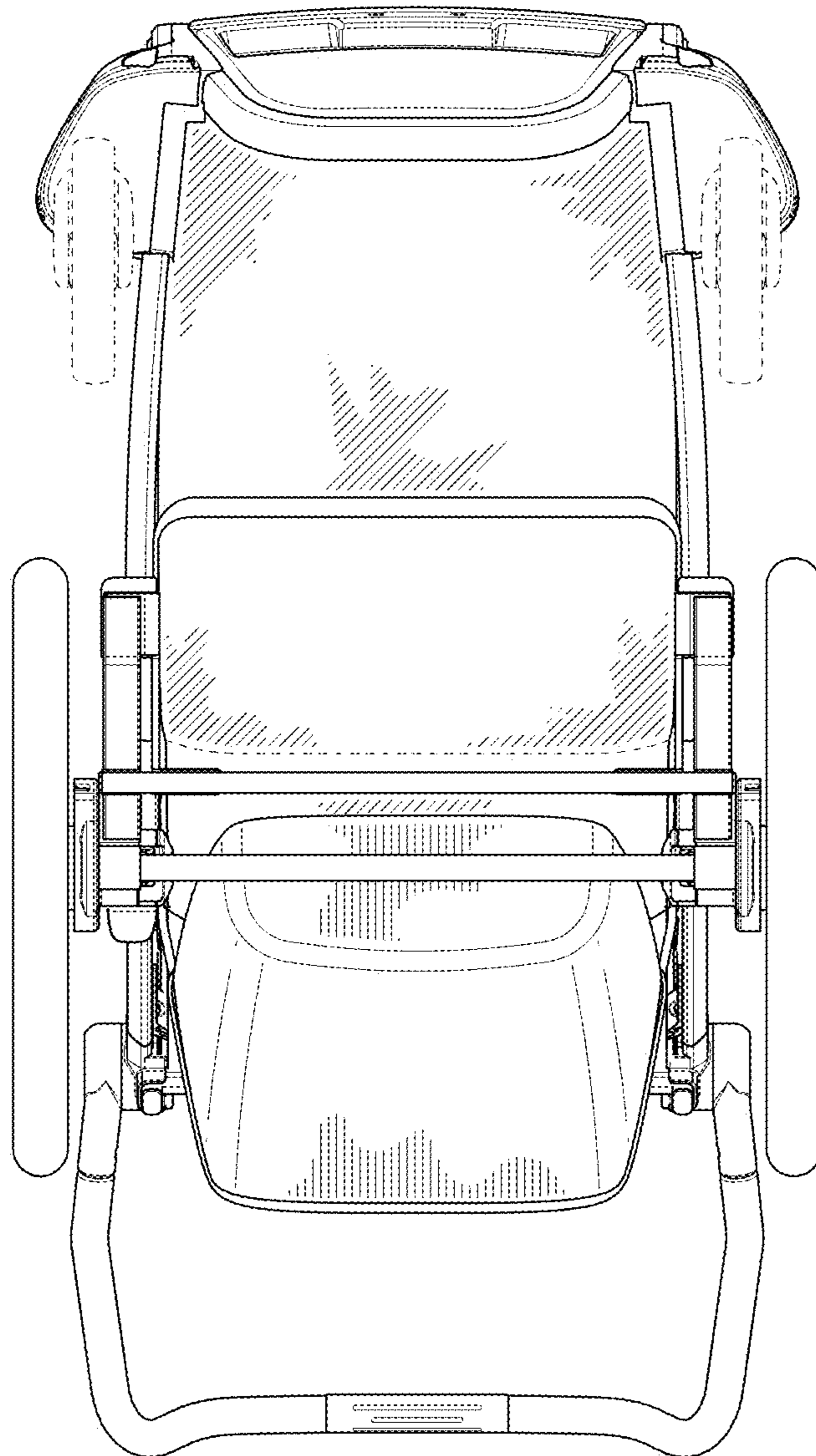

FIG. 14