

US00D937111S

(12) **United States Design Patent** (10) **Patent No.:** **US D937,111 S**
Wang (45) **Date of Patent:** **** *Nov. 30, 2021**

(54) **CALIBRATION SUPPORT FOR A VEHICLE**

D853,403 S * 7/2019 Lyu D14/451
D877,745 S * 3/2020 Knapp D14/452
D883,122 S * 5/2020 Cai D10/103
D883,123 S * 5/2020 Cai D10/103

(71) Applicant: **AUTEL INTELLIGENT TECHNOLOGY CORP., LTD.**,
Guangdong (CN)

(Continued)

(72) Inventor: **Yongshuai Wang**, Guangdong (CN)

Primary Examiner — Susan E Krakower
Assistant Examiner — Jerry Shiuan-Hua Hsu

(73) Assignee: **AUTEL INTELLIGENT TECHNOLOGY CORP., LTD.**,
Shenzhen (CN)

(57) **CLAIM**

(*) Notice: This patent is subject to a terminal disclaimer.

I claim the ornamental design for a calibration support for a vehicle, as shown and described.

(**) Term: **15 Years**

DESCRIPTION

(21) Appl. No.: **29/704,764**

(22) Filed: **Sep. 6, 2019**

(30) **Foreign Application Priority Data**

Mar. 8, 2019 (CN) 201930094055.7

(51) **LOC (13) Cl.** **10-04**

(52) **U.S. Cl.**
USPC **D10/103**

(58) **Field of Classification Search**
USPC D8/349, 354, 363, 376, 38; D10/46, 65,
D10/70, 103; D14/447-452, 371, 372,
D14/373, 374, 375-382, 126, 127, 128,
D14/129, 239
CPC F16M 11/242; F16M 11/2014; F16M
11/105; F16M 11/24; G01S 13/931; G01S
7/4026; G01B 11/27; G01B 11/2755
See application file for complete search history.

FIG. 1 is a front elevational view of a calibration support for a vehicle showing my new design;
FIG. 2 is a back elevational view thereof;
FIG. 3 is a left side elevational view thereof;
FIG. 4 is a right side elevational view thereof;
FIG. 5 is a top plan view thereof;
FIG. 6 is a bottom plan view thereof;
FIG. 7 is a perspective view thereof;
FIG. 8 is another perspective view thereof;
FIG. 9 is a front elevational view thereof in a changed status;
FIG. 10 is a back elevational view thereof in a changed status;
FIG. 11 is a left side elevational view thereof in a changed status;
FIG. 12 is a right side elevational view thereof in a changed status;
FIG. 13 is a top plan view thereof in a changed status;
FIG. 14 is a bottom plan view thereof in a changed status;
FIG. 15 is a perspective view thereof in a changed status; and,
FIG. 16 is another perspective view thereof in a changed status. The broken lines in the drawings illustrate portions of the calibration support for a vehicle that form no part of the claimed design.

(56) **References Cited**

U.S. PATENT DOCUMENTS

8,534,615 B2 * 9/2013 Huang F16M 11/24
248/125.1
10,323,936 B2 * 6/2019 Leikert G01B 11/2755

1 Claim, 15 Drawing Sheets

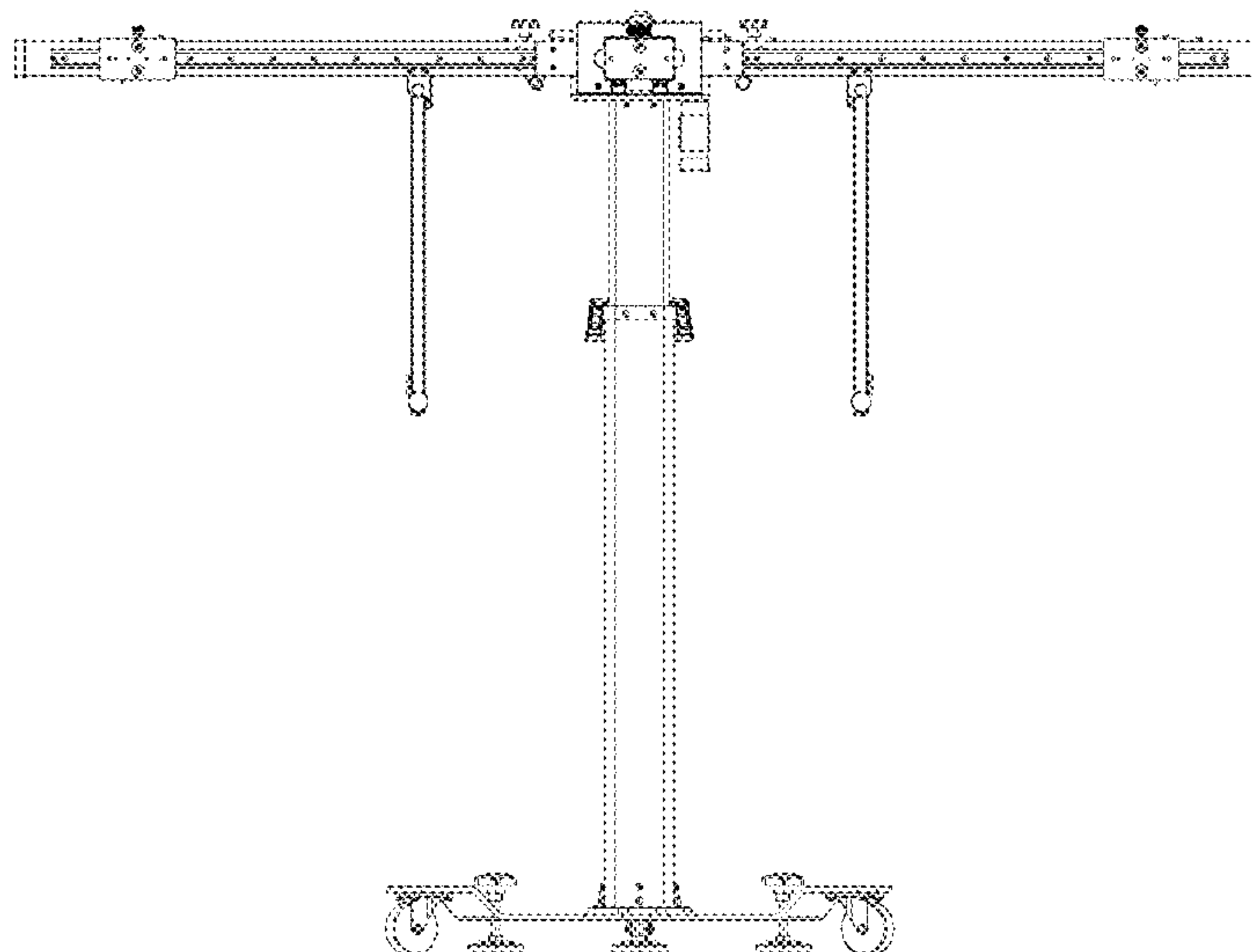

(56)

References Cited

U.S. PATENT DOCUMENTS

D894,197 S * 8/2020 Knapp D14/452
D895,635 S * 9/2020 Sitoh D14/452
10,794,996 B2 * 10/2020 Qiu G01S 7/4026
10,821,607 B2 * 11/2020 Chen G01B 11/27
D905,700 S * 12/2020 Lu D14/452
10,921,426 B2 * 2/2021 Tang G01S 13/931
2007/0205340 A1 * 9/2007 Jung F16M 11/105
248/125.9
2017/0202351 A1 * 7/2017 Bowman F16M 11/2014
2019/0187249 A1 * 6/2019 Harmer F16M 11/242
2019/0249985 A1 * 8/2019 Stieff G01S 7/4972

* cited by examiner

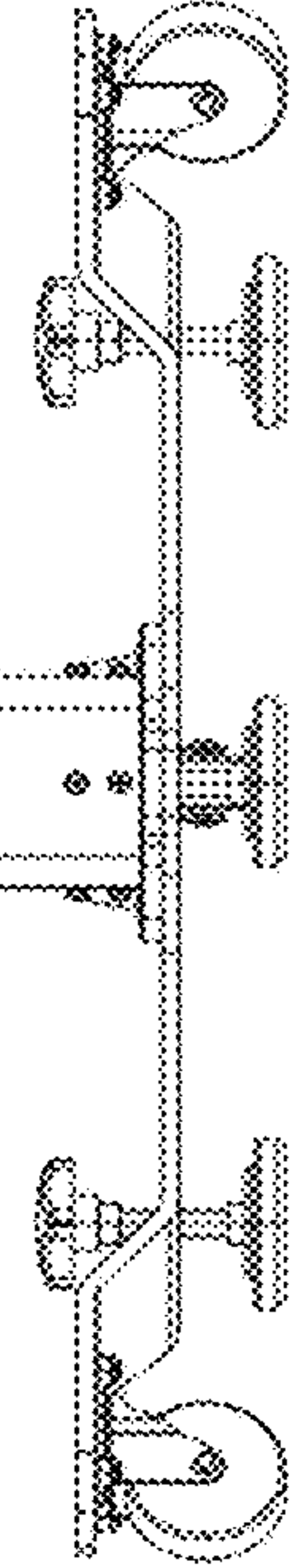
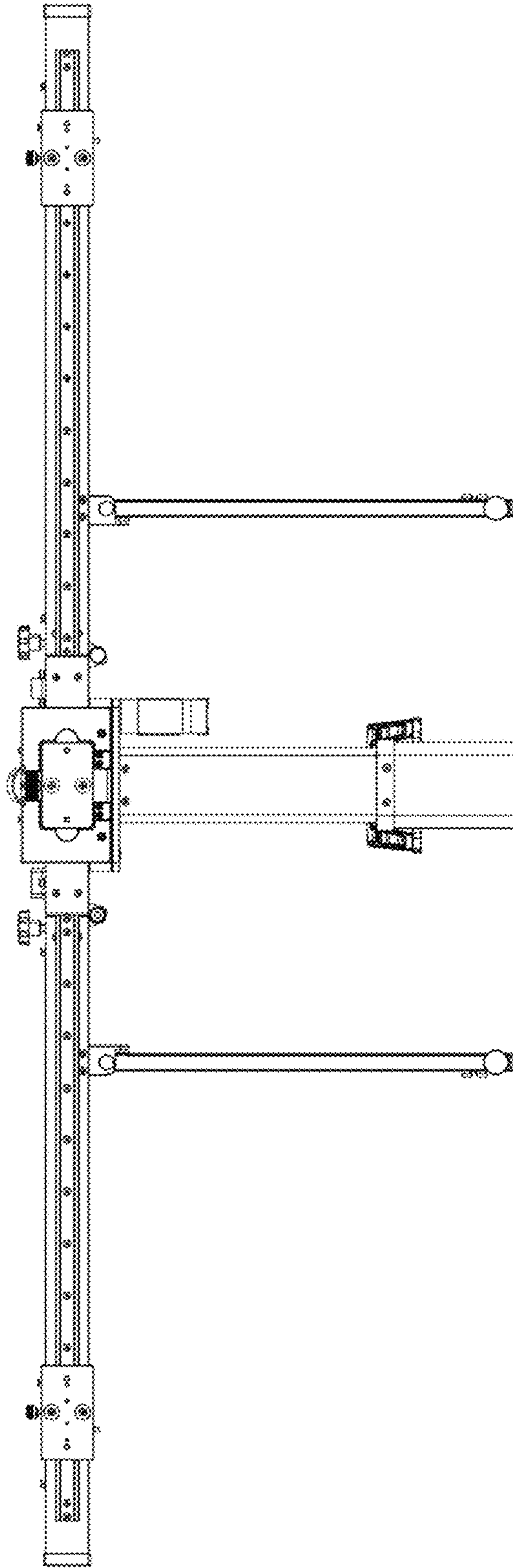

FIG. 1

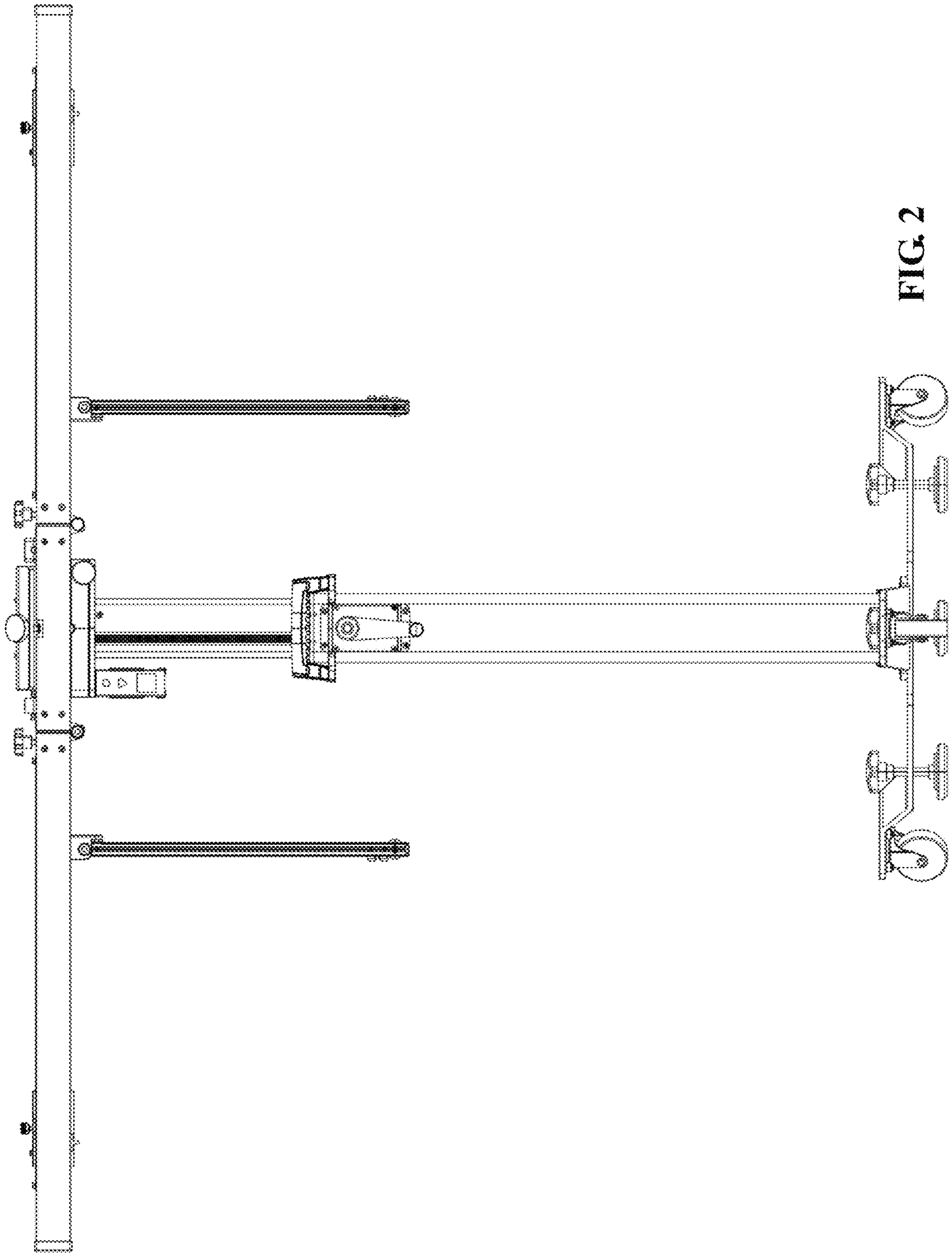

FIG. 2

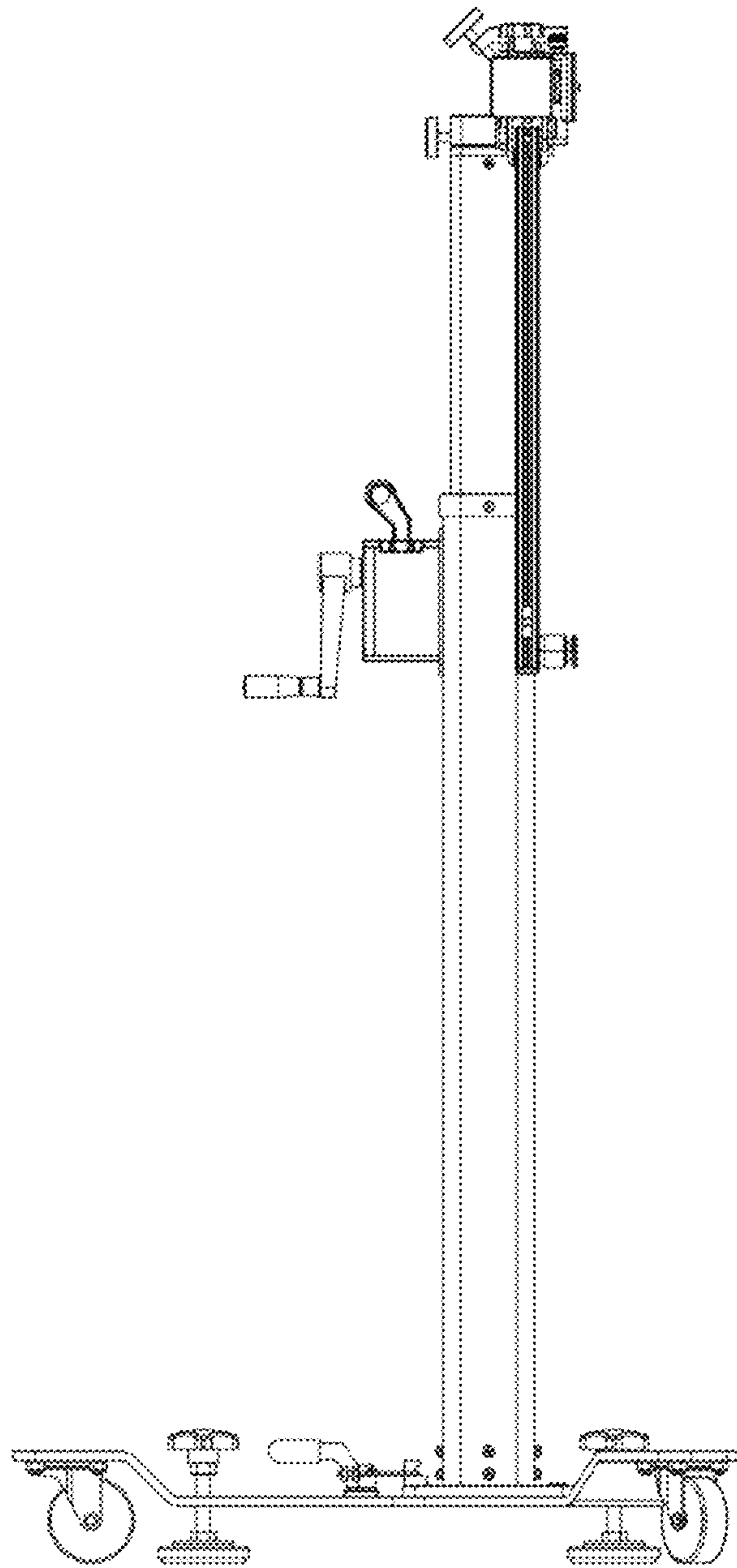

FIG. 3

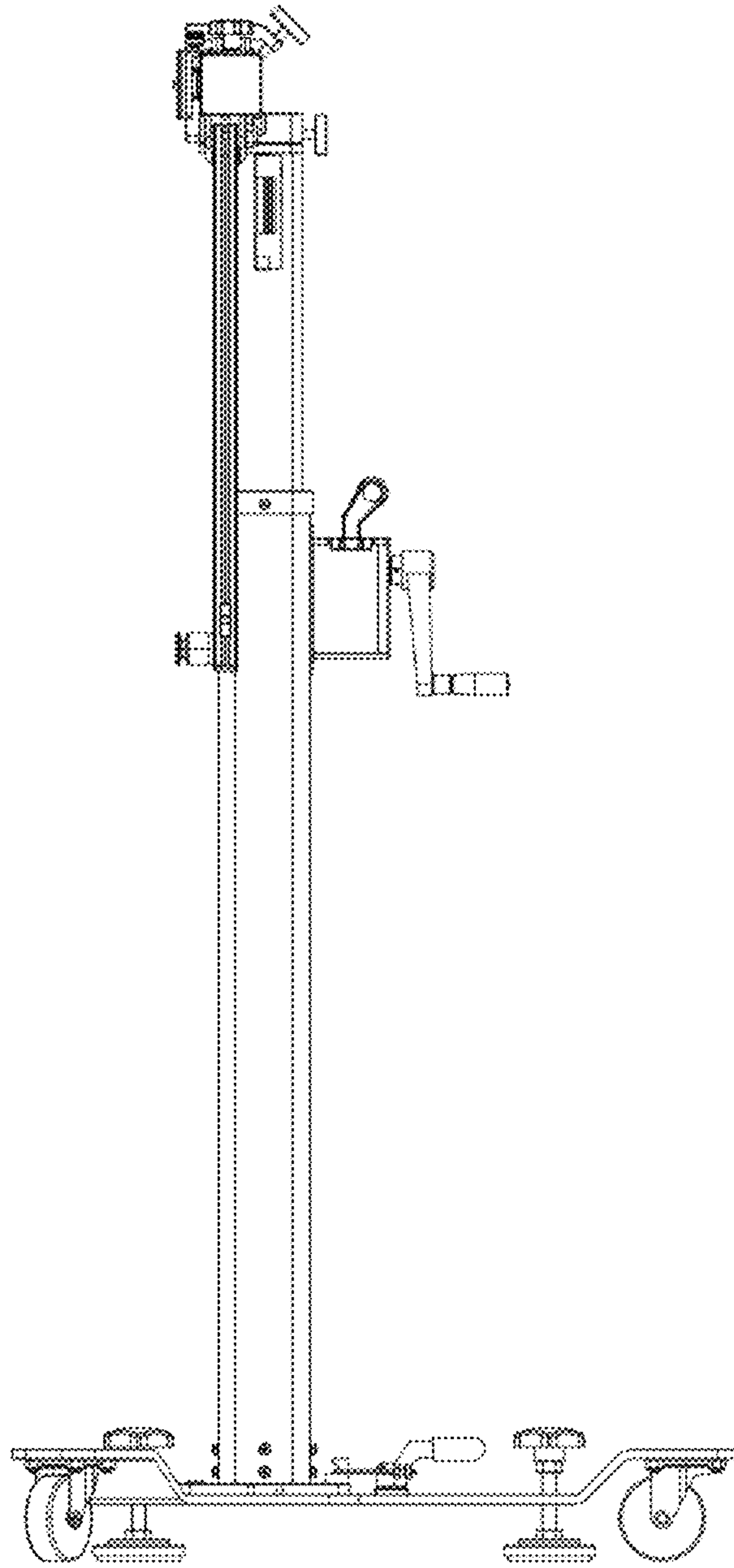

FIG. 4

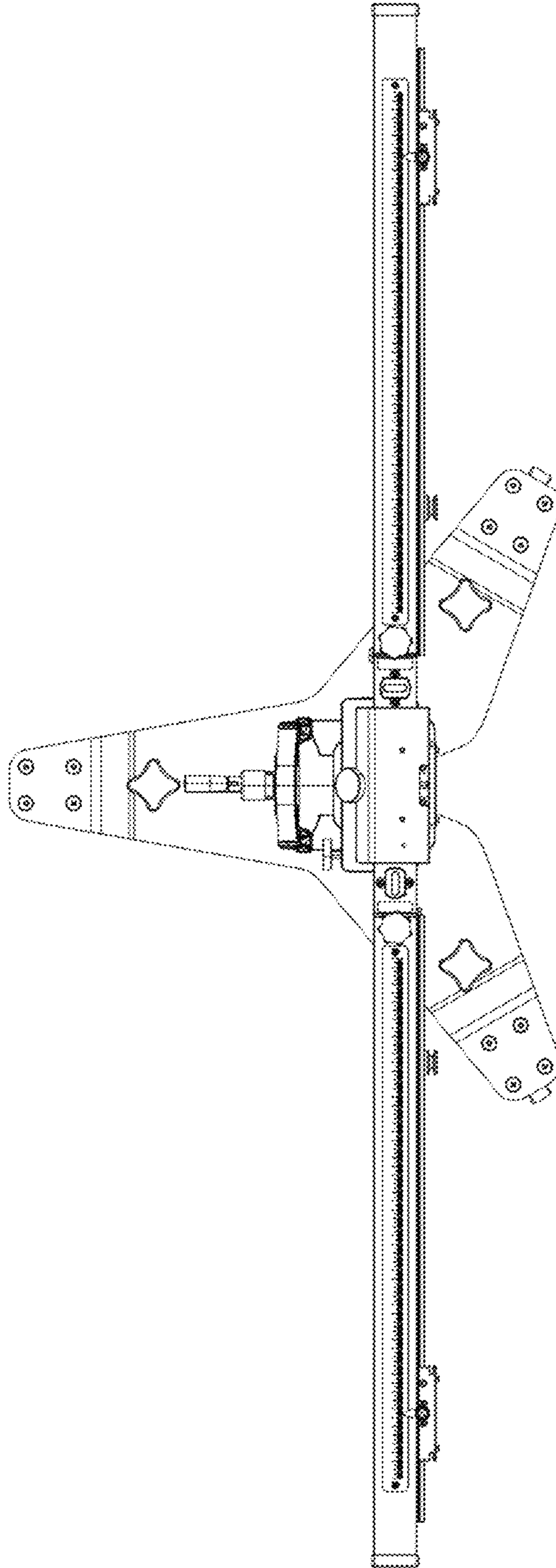

FIG. 5

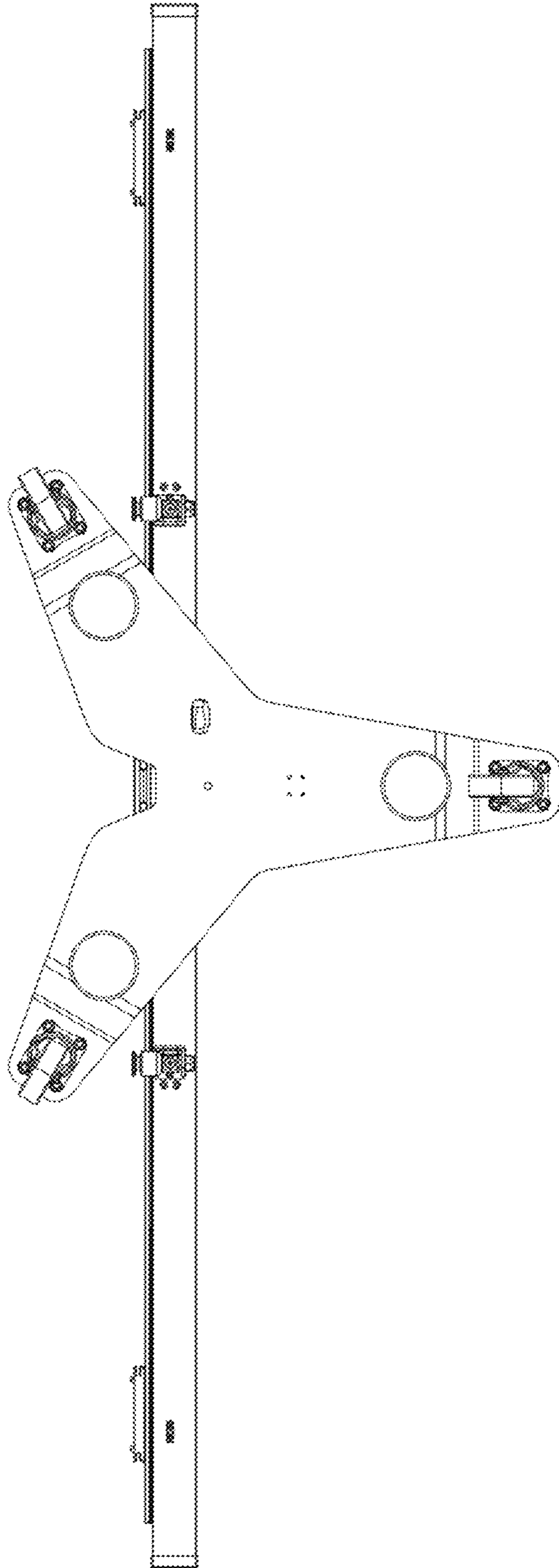

FIG. 6

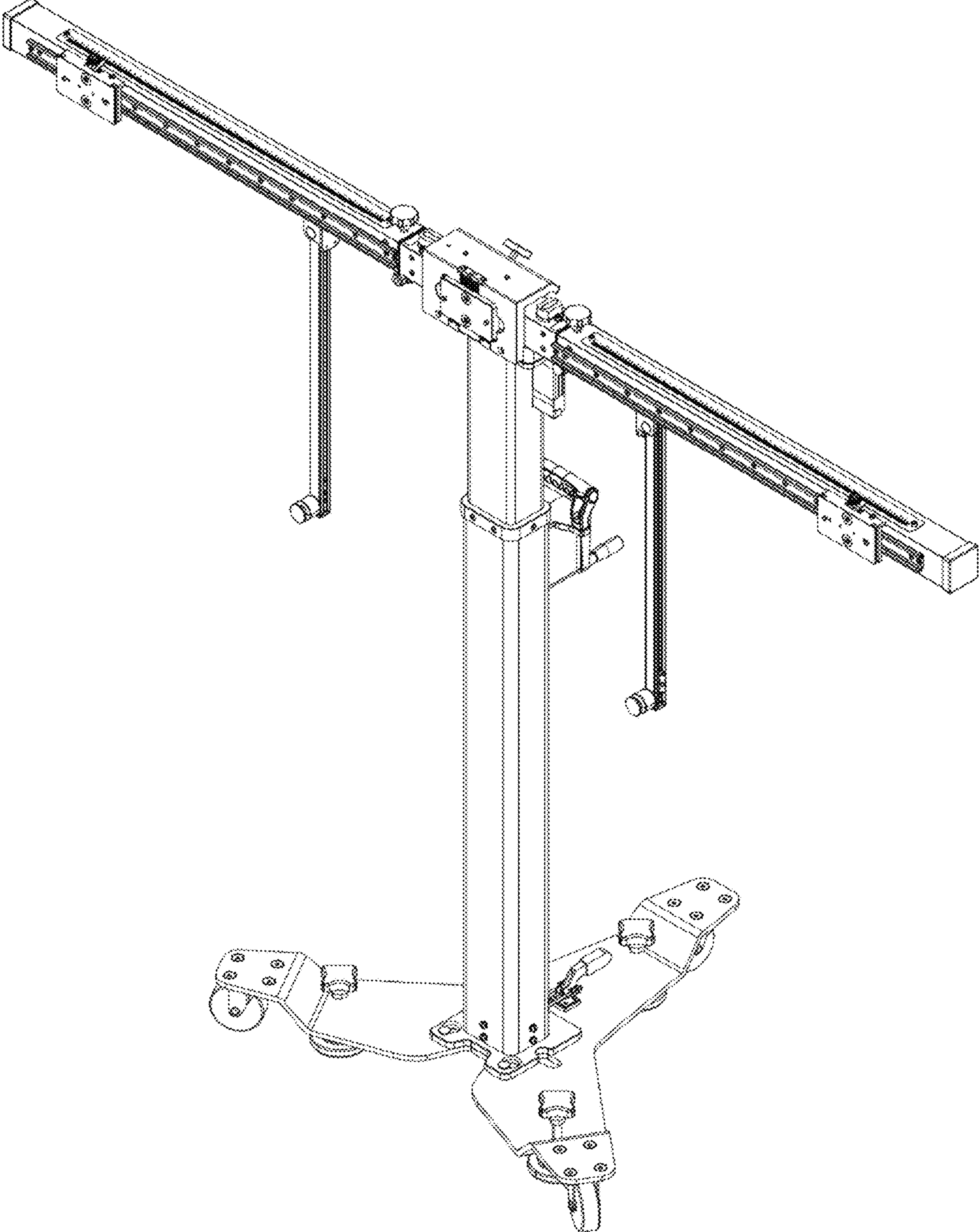

FIG. 7

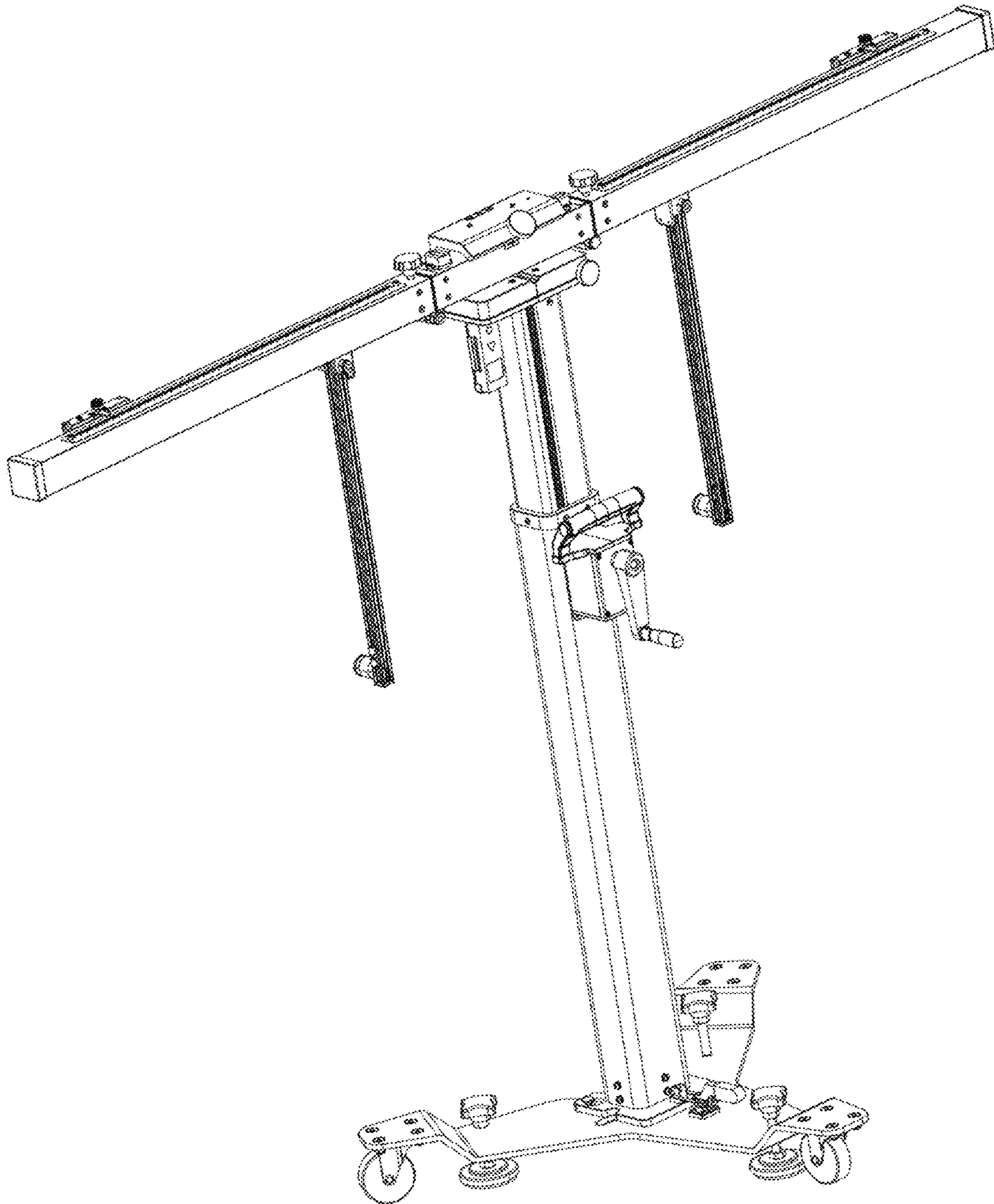

FIG. 8

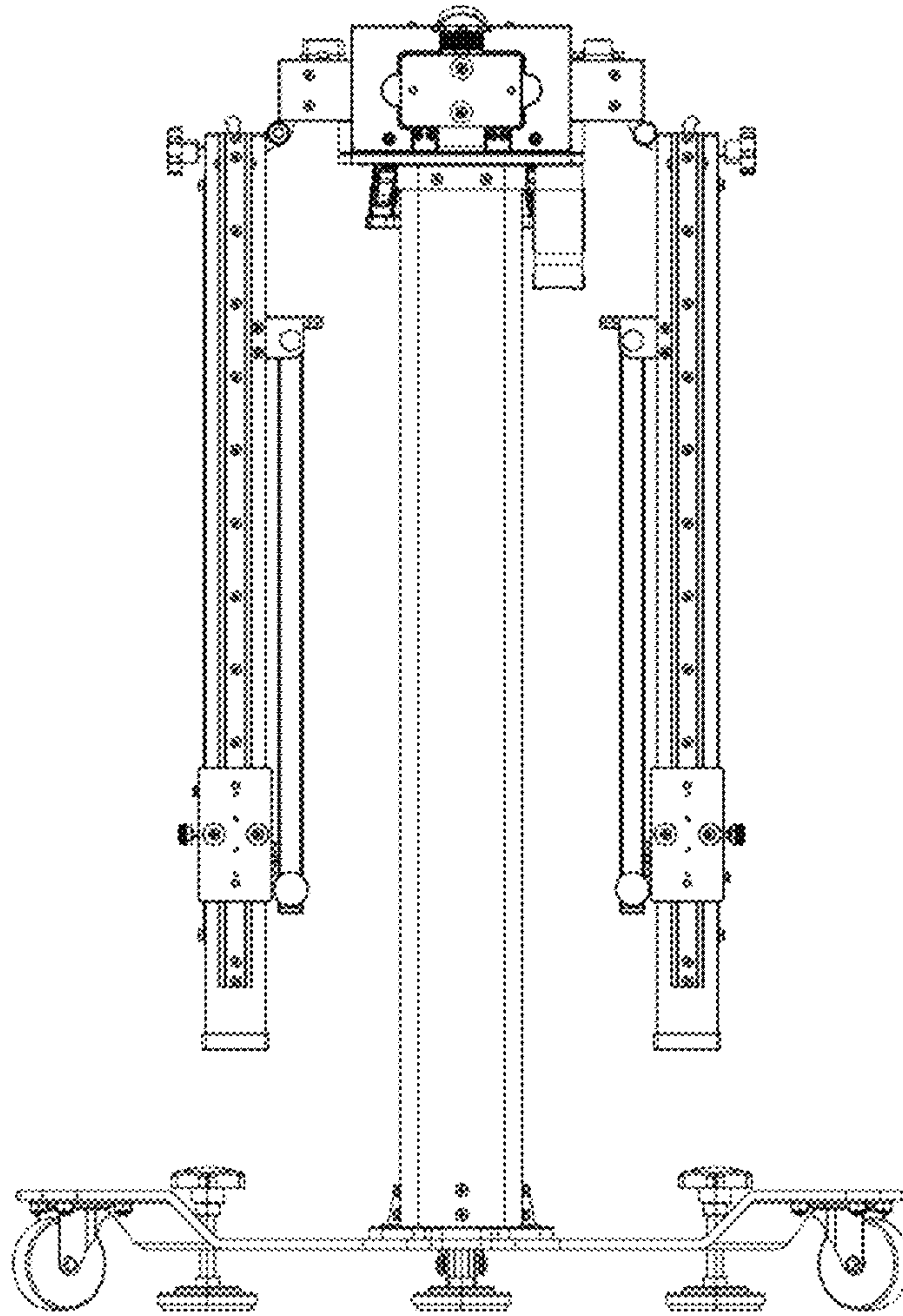

FIG. 9

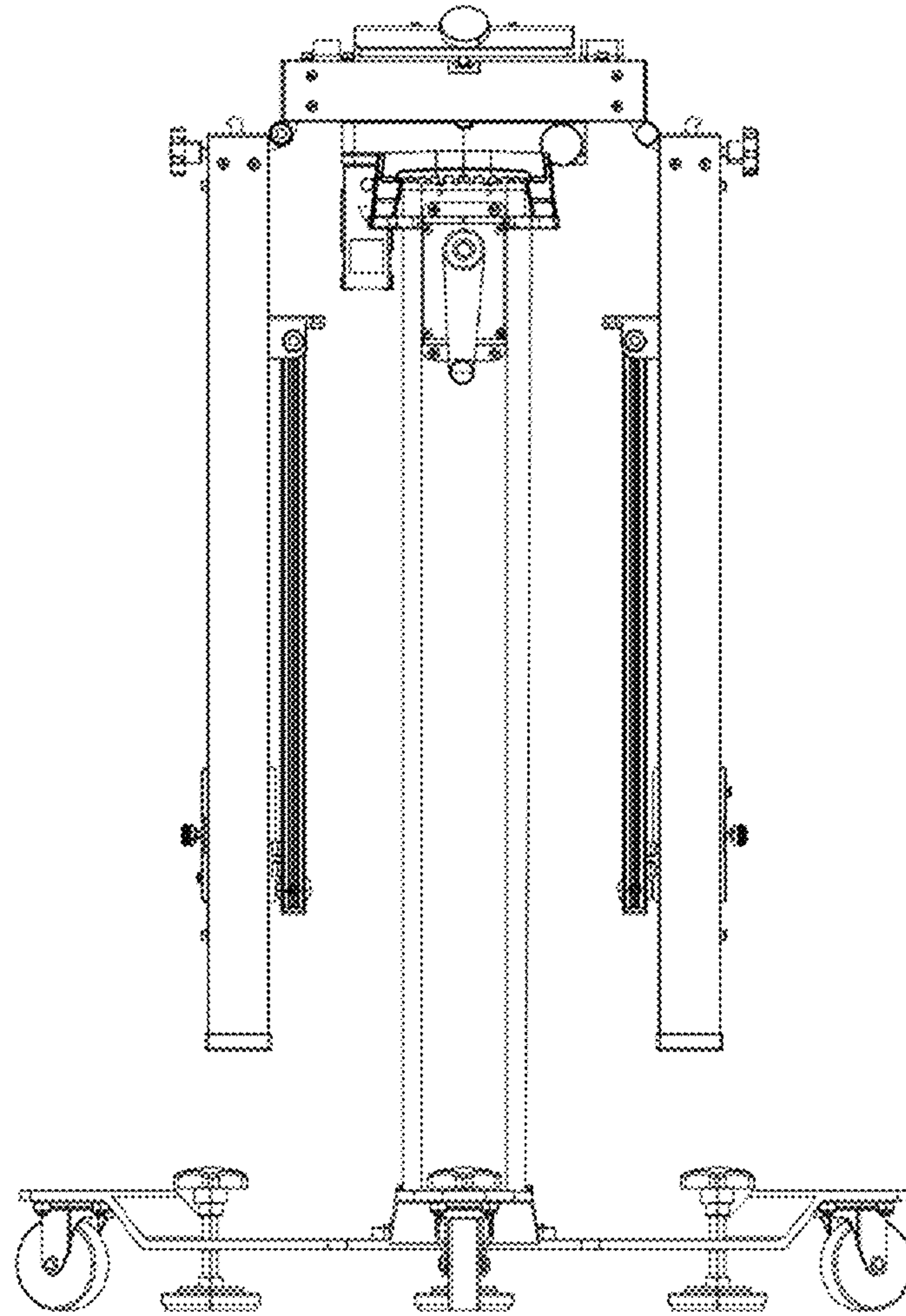

FIG. 10

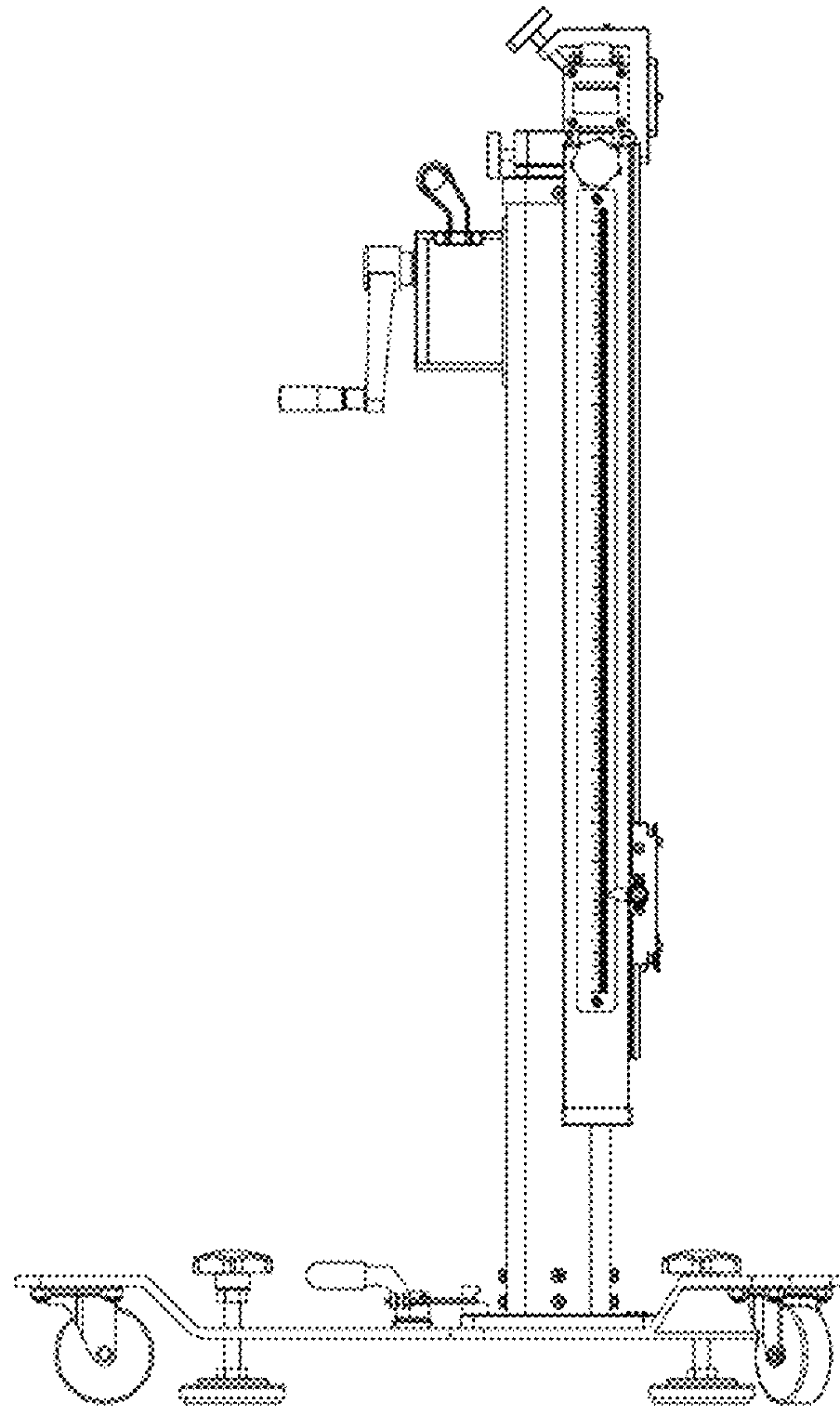

FIG. 11

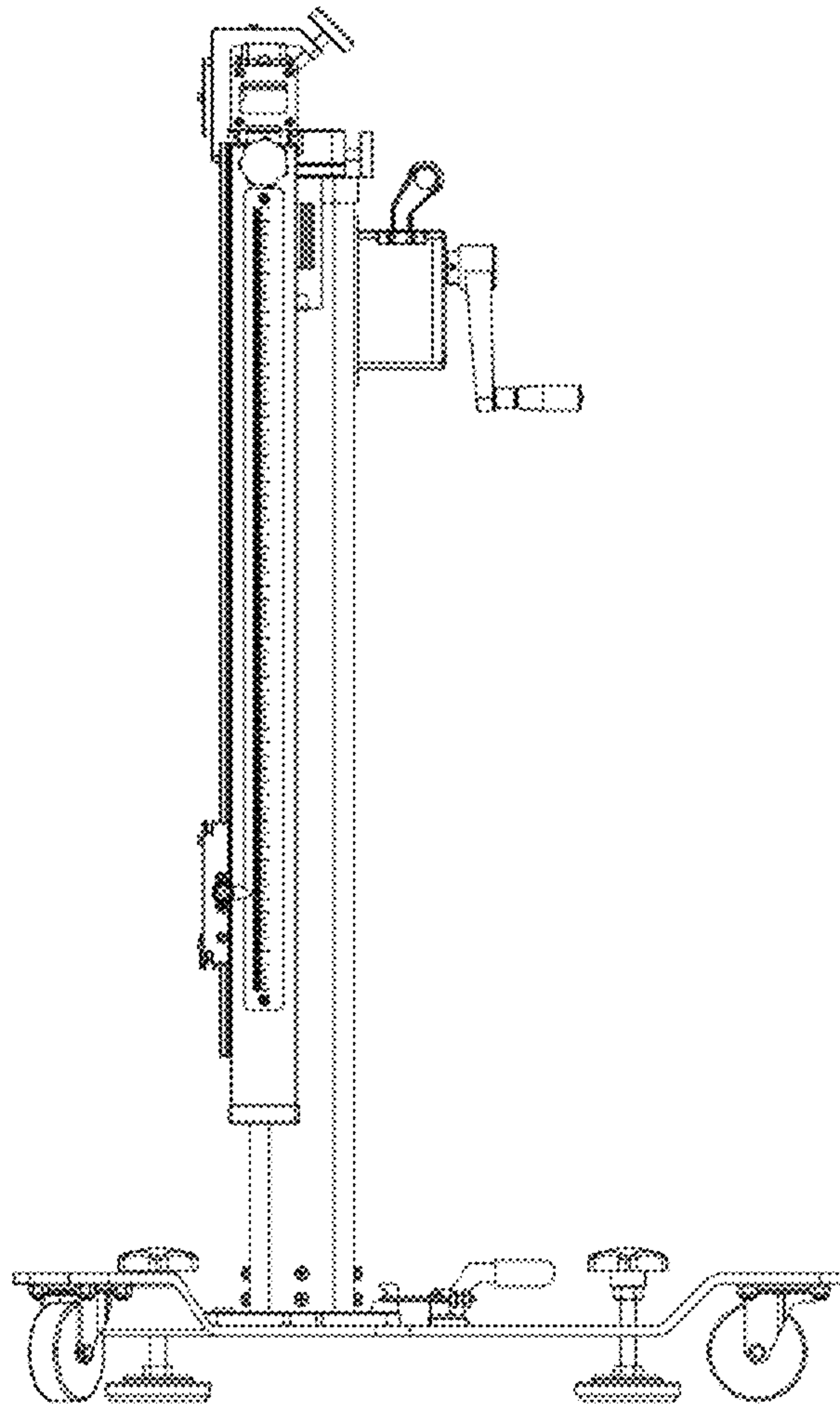

FIG. 12

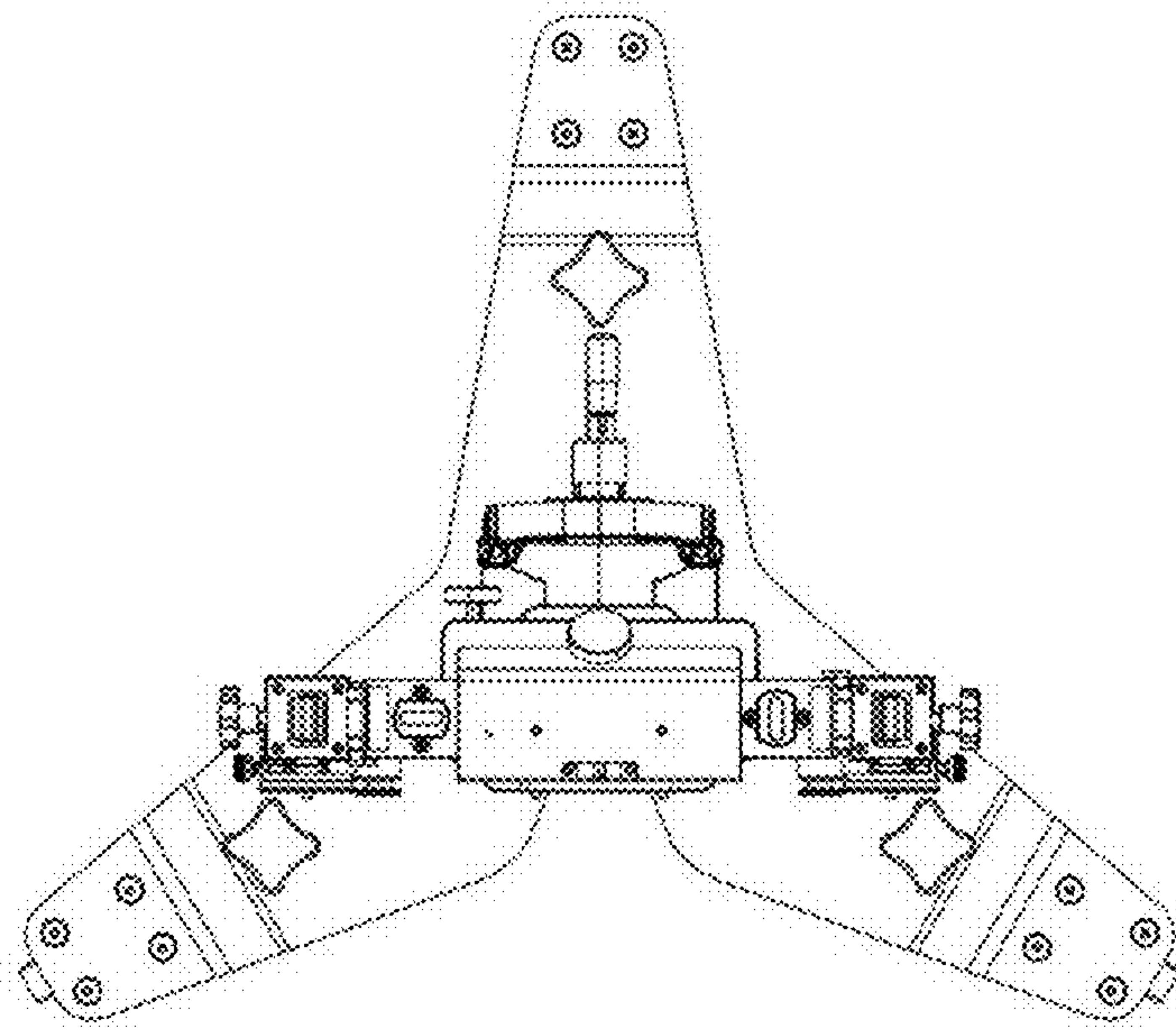

FIG. 13

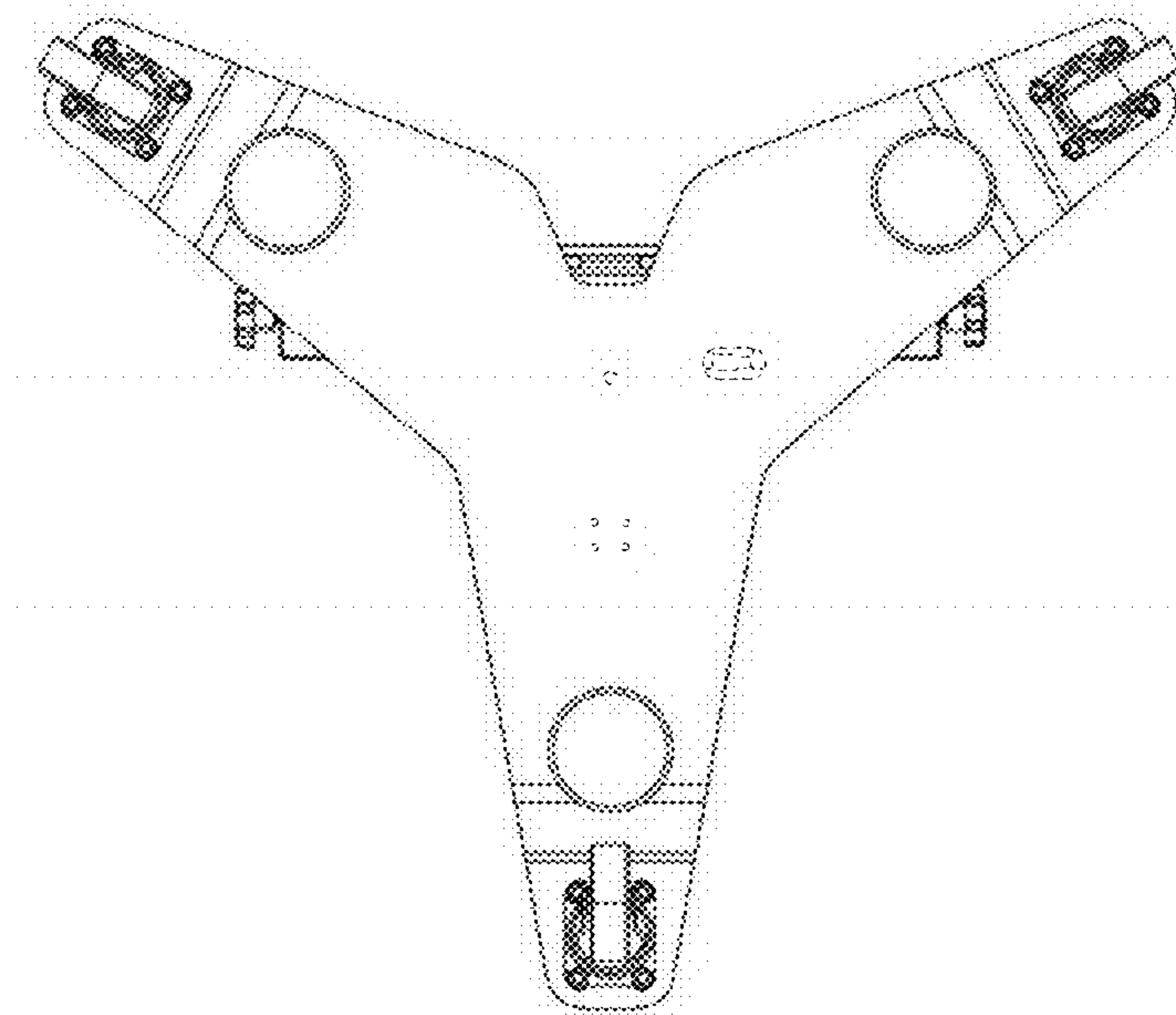

FIG. 14

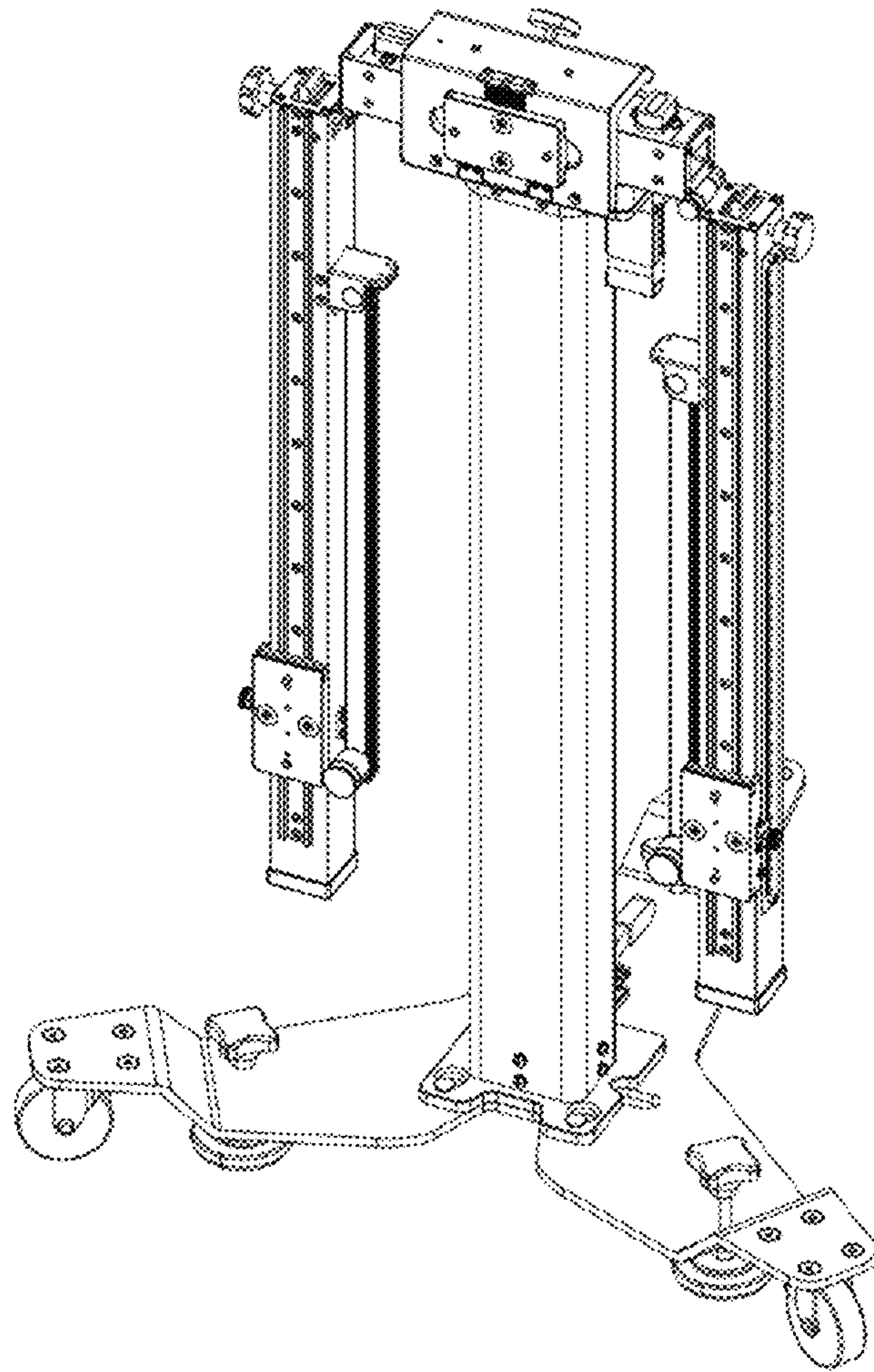

FIG. 15

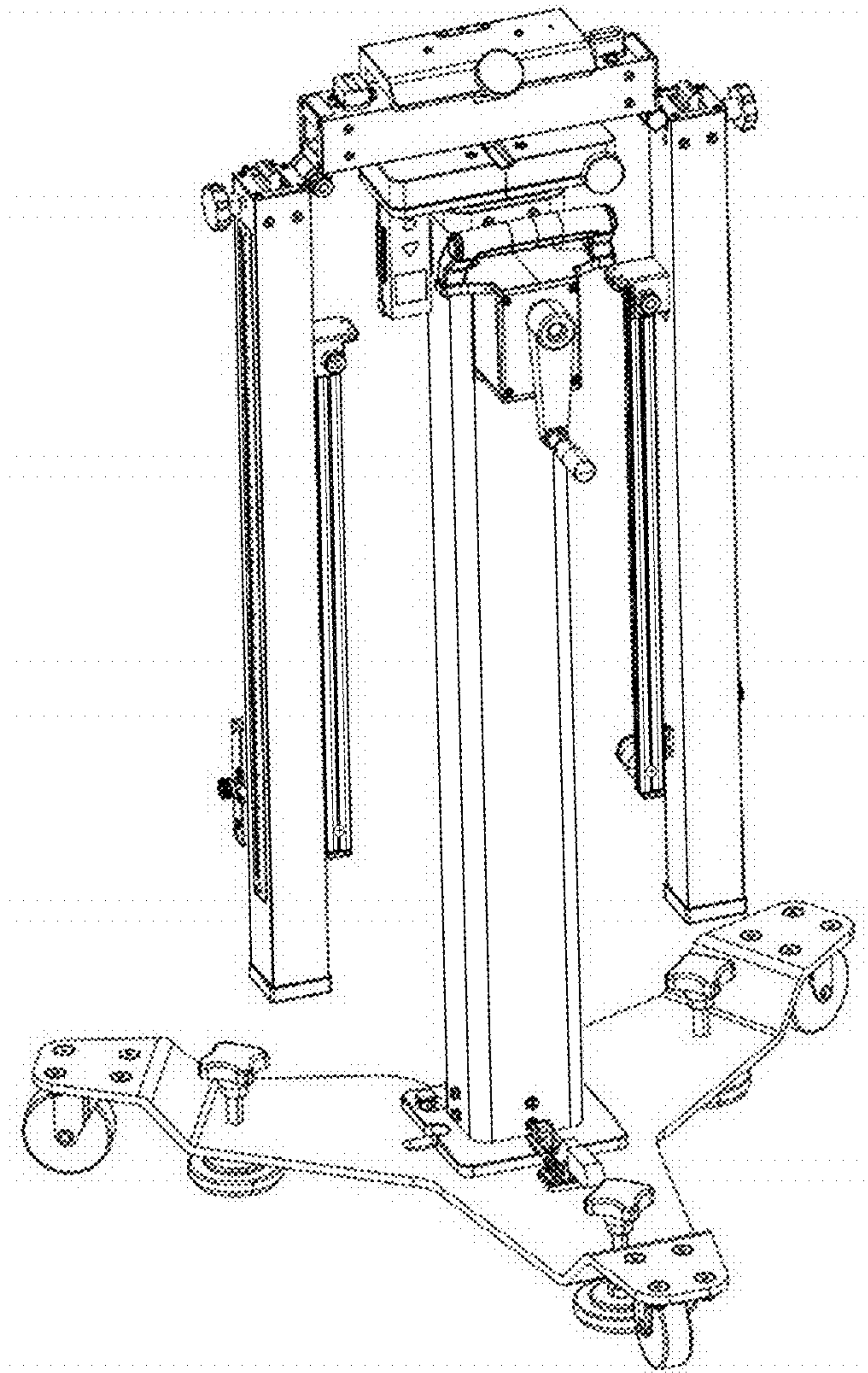

FIG. 16