



US00D937024S

(12) **United States Design Patent**  
**Deevers et al.**

(10) **Patent No.:** **US D937,024 S**

(45) **Date of Patent:** **\*\* Nov. 30, 2021**

(54) **BACKREST**

4,555,139 A 11/1985 Leib  
4,826,249 A 5/1989 Bradbury  
4,869,554 A 9/1989 Abu-Ise et al.

(Continued)

(71) Applicant: **Steelcase Inc.**, Grand Rapids, MI (US)

(72) Inventors: **Nickolaus William Charles Deevers**,  
Holland, MI (US); **Kurt R. Heidmann**,  
Grand Rapids, MI (US); **Gordon J.**  
**Peterson**, Rockford, MI (US); **Mark**  
**Spoelhof**, Grand Rapids, MI (US);  
**James Ludwig**, Grand Rapids, MI  
(US); **Alyssa Anne Robert**, Kentwood,  
MI (US)

FOREIGN PATENT DOCUMENTS

JP 2012085897 A 5/2012  
JP 2013-132403 A 7/2013  
JP 2020062346 A 4/2020

(73) Assignee: **Steelcase Inc.**, Grand Rapids, MI (US)

(\*\*) Term: **15 Years**

OTHER PUBLICATIONS

Sedus brochure, "se:motion, Office swivel chair for agile working",  
obtained from the Internet at: www.sedus.com, not dated, 20 pgs.

*Primary Examiner* — R. Johnson

(74) *Attorney, Agent, or Firm* — Crowell & Moring LLP

(21) Appl. No.: **29/724,818**

(57) **CLAIM**

The ornamental design for a backrest, as shown and  
described.

(22) Filed: **Feb. 19, 2020**

(51) **LOC (13) Cl.** ..... **06-01**

**DESCRIPTION**

(52) **U.S. Cl.**

USPC ..... **D6/716.4**

(58) **Field of Classification Search**

USPC ..... D6/334, 361, 364, 365, 366, 367, 379,  
D6/380, 716.1, 716.2, 716.4

CPC .... A47C 3/00; A47C 3/18; A47C 3/20; A47C  
3/026; A47C 1/00; A47C 1/02; A47C  
1/022; A47C 1/03; A47C 1/14; A47C  
1/143; A47C 7/24; A47C 7/36; A47C  
7/46; A47C 7/18; A47C 7/40; A47C 7/54  
See application file for complete search history.

FIG. 1 is a front perspective view of a backrest;  
FIG. 2 is a rear perspective view of the backrest shown in  
FIG. 1;  
FIG. 3 is a right side view of the backrest shown in FIG. 1;  
FIG. 4 is a left side view of the backrest shown in FIG. 1;  
FIG. 5 is front view of the backrest shown in FIG. 1;  
FIG. 6 is a rear view of the backrest shown in FIG. 1;  
FIG. 7 is a top view of the backrest shown in FIG. 1; and,  
FIG. 8 is a bottom view of the backrest shown in FIG. 1.  
The ornamental design which is claimed is shown in solid  
lines in the drawings. The structures shown in broken lines  
in FIGS. 1-8 are for environmental purposes only and do not  
form any part of the claimed design. The broken lines shown  
in FIGS. 1-8 along the bottom portion of the backrest  
between the environmental structure and the claimed design  
show the boundary of the claimed design and do not form  
any part thereof.

(56) **References Cited**

U.S. PATENT DOCUMENTS

3,041,109 A 6/1962 Eames et al.  
3,606,464 A 9/1971 Arbuthnot  
4,545,614 A 10/1985 Abu-Ise et al.  
4,555,136 A 11/1985 Dranger

**1 Claim, 6 Drawing Sheets**

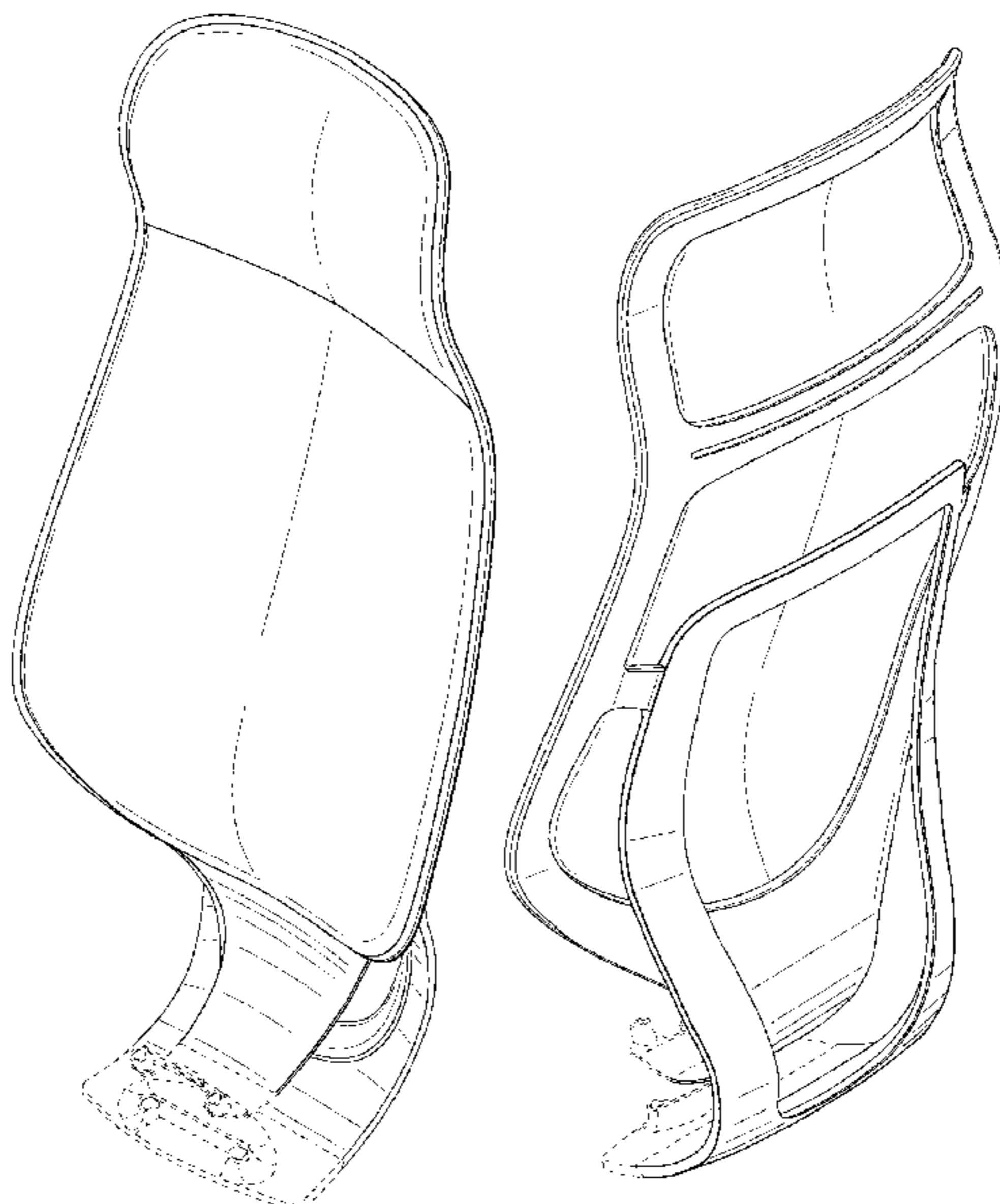

(56)

References Cited

U.S. PATENT DOCUMENTS

5,354,120 A 10/1994 Völkle  
 5,457,968 A 10/1995 McClintock et al.  
 5,795,026 A 8/1998 Dral  
 5,855,991 A 1/1999 McLarty, III  
 6,050,646 A 4/2000 Stenzel et al.  
 6,341,822 B2 1/2002 Apissomian  
 6,632,756 B1 10/2003 Waldrop et al.  
 D487,359 S 3/2004 Giugiaro  
 6,729,691 B2 5/2004 Koepke et al.  
 6,749,261 B2 6/2004 Knoblock et al.  
 D496,813 S 10/2004 Nakajima  
 6,814,412 B2 11/2004 Cramb, III et al.  
 6,951,370 B1 \* 10/2005 Hsu ..... A47C 3/20  
 297/260.2  
 6,983,997 B2 1/2006 Wilkerson et al.  
 D517,820 S 3/2006 Citterio  
 7,055,911 B2 6/2006 Simpson et al.  
 D527,920 S 9/2006 Giugiaro  
 D528,811 S 9/2006 Giugiaro  
 7,159,943 B2 1/2007 Costaglia  
 D549,975 S 9/2007 Fancelli  
 D555,377 S \* 11/2007 Pensi ..... D6/366  
 D557,917 S 12/2007 Nakamura  
 D576,809 S 9/2008 Christianson et al.  
 7,425,039 B2 9/2008 Lin  
 7,441,839 B2 10/2008 Pennington et al.  
 7,568,765 B2 8/2009 Bräuning  
 7,712,833 B2 5/2010 Ueda  
 7,837,272 B2 11/2010 Masunaga et al.  
 D641,983 S 7/2011 Hazzard  
 D646,088 S 10/2011 Ballendat  
 8,087,727 B2 1/2012 Parker et al.  
 8,113,582 B2 2/2012 Liu  
 D658,904 S 5/2012 Chen  
 D663,129 S 7/2012 Greutmann  
 8,251,448 B2 8/2012 Machael  
 D675,456 S 2/2013 Sexton  
 D683,150 S 5/2013 Smith et al.  
 D683,151 S 5/2013 Smith et al.  
 D688,497 S 8/2013 Smith et al.  
 D688,498 S 8/2013 Smith et al.  
 D688,499 S 8/2013 Smith et al.  
 D688,500 S 8/2013 Smith et al.  
 D688,501 S 8/2013 Smith et al.  
 D688,503 S 8/2013 Smith et al.  
 D688,504 S 8/2013 Smith et al.  
 D688,505 S 8/2013 Smith et al.  
 D689,312 S 9/2013 Smith et al.  
 D689,313 S 9/2013 Smith et al.  
 D689,314 S 9/2013 Smith et al.  
 D689,317 S 9/2013 Smith et al.  
 D689,318 S 9/2013 Smith et al.  
 D690,146 S 9/2013 Smith et al.  
 D690,547 S 10/2013 Smith et al.  
 D694,536 S 12/2013 Smith et al.  
 D694,537 S 12/2013 Smith et al.  
 D694,538 S 12/2013 Smith et al.  
 D694,539 S 12/2013 Smith et al.  
 D694,540 S 12/2013 Smith et al.  
 D695,034 S 12/2013 Smith et al.  
 D697,726 S 1/2014 Smith et al.  
 D697,728 S 1/2014 Smith et al.  
 D697,729 S 1/2014 Smith et al.  
 D697,730 S 1/2014 Smith et al.  
 D698,164 S 1/2014 Smith et al.  
 D698,165 S 1/2014 Smith et al.  
 D698,166 S 1/2014 Smith et al.  
 D699,957 S 2/2014 Smith et al.  
 D699,958 S 2/2014 Smith et al.

D699,959 S 2/2014 Smith et al.  
 D699,994 S 2/2014 Smith et al.  
 D701,053 S 3/2014 Smith et al.  
 8,690,249 B2 4/2014 Kang et al.  
 D707,976 S 7/2014 Smith  
 D708,882 S 7/2014 Hsuan-Chin  
 8,794,701 B2 8/2014 Nakayama et al.  
 8,998,339 B2 4/2015 Peterson et al.  
 D733,445 S 7/2015 Izawa et al.  
 D742,676 S 11/2015 Smith et al.  
 D742,677 S 11/2015 Smith et al.  
 D742,678 S 11/2015 Smith et al.  
 D750,406 S 3/2016 Smith et al.  
 9,560,917 B2 2/2017 Roslund, Jr.  
 D781,604 S 3/2017 Smith et al.  
 D781,605 S 3/2017 Smith et al.  
 9,622,579 B2 4/2017 Wilkinson et al.  
 9,648,957 B2 5/2017 Su  
 D792,717 S \* 7/2017 Webb ..... D6/366  
 D802,951 S 11/2017 Ludwig et al.  
 D802,952 S 11/2017 Ludwig et al.  
 D804,209 S 12/2017 Ludwig et al.  
 D804,839 S 12/2017 Ludwig et al.  
 D804,840 S 12/2017 Ludwig et al.  
 D804,841 S 12/2017 Ludwig et al.  
 D804,875 S 12/2017 Ludwig et al.  
 D804,876 S 12/2017 Ludwig et al.  
 D808,187 S 1/2018 Ludwig et al.  
 D821,793 S 7/2018 Ludwig et al.  
 D825,971 S 8/2018 Scagnellato  
 D834,844 S 12/2018 Chan et al.  
 10,173,567 B2 1/2019 Madrigal et al.  
 D852,525 S 7/2019 Peterson  
 D852,526 S \* 7/2019 Peterson ..... D6/366  
 D863,802 S \* 10/2019 Wang ..... D6/366  
 D869,872 S 12/2019 Deevers  
 D870,479 S 12/2019 Deevers et al.  
 D873,043 S 1/2020 Su  
 D873,576 S 1/2020 Engelhardt  
 D874,202 S 2/2020 Schmitz et al.  
 D878,789 S \* 3/2020 Wang ..... D6/366  
 D879,523 S 3/2020 Lampela et al.  
 D880,885 S \* 4/2020 Li ..... D6/366  
 D881,621 S 4/2020 Jin et al.  
 10,617,226 B1 4/2020 Liao  
 D883,690 S 5/2020 Dassen  
 D883,691 S 5/2020 Dassen  
 D887,157 S 6/2020 Holbrook  
 D899,836 S 10/2020 Chu  
 D902,614 S \* 11/2020 Peng ..... D6/366  
 D903,353 S \* 12/2020 Meda ..... D6/366  
 D906,711 S \* 1/2021 Li ..... D6/366  
 D907,935 S 1/2021 Deevers  
 D908,381 S \* 1/2021 Breen ..... D6/366  
 D912,419 S 3/2021 Chen  
 2003/0189367 A1 10/2003 Erker  
 2007/0057560 A1 3/2007 Fookes  
 2007/0108821 A1 5/2007 Ueda  
 2008/0100121 A1 5/2008 Serber  
 2009/0018833 A1 1/2009 Kozat et al.  
 2009/0261644 A1 10/2009 Piretti  
 2011/0233979 A1 9/2011 An  
 2013/0341980 A1 12/2013 Halliday et al.  
 2014/0077429 A1 3/2014 Battey  
 2014/0077541 A1 3/2014 Krupiczewicz  
 2014/0077548 A1 \* 3/2014 Peterson ..... A47C 3/00  
 297/284.4  
 2016/0220025 A1 8/2016 Piretti  
 2018/0310721 A1 11/2018 Schmitz et al.  
 2020/0085194 A1 3/2020 Maier et al.  
 2020/0305610 A1 10/2020 Bock

\* cited by examiner

FIG. 1

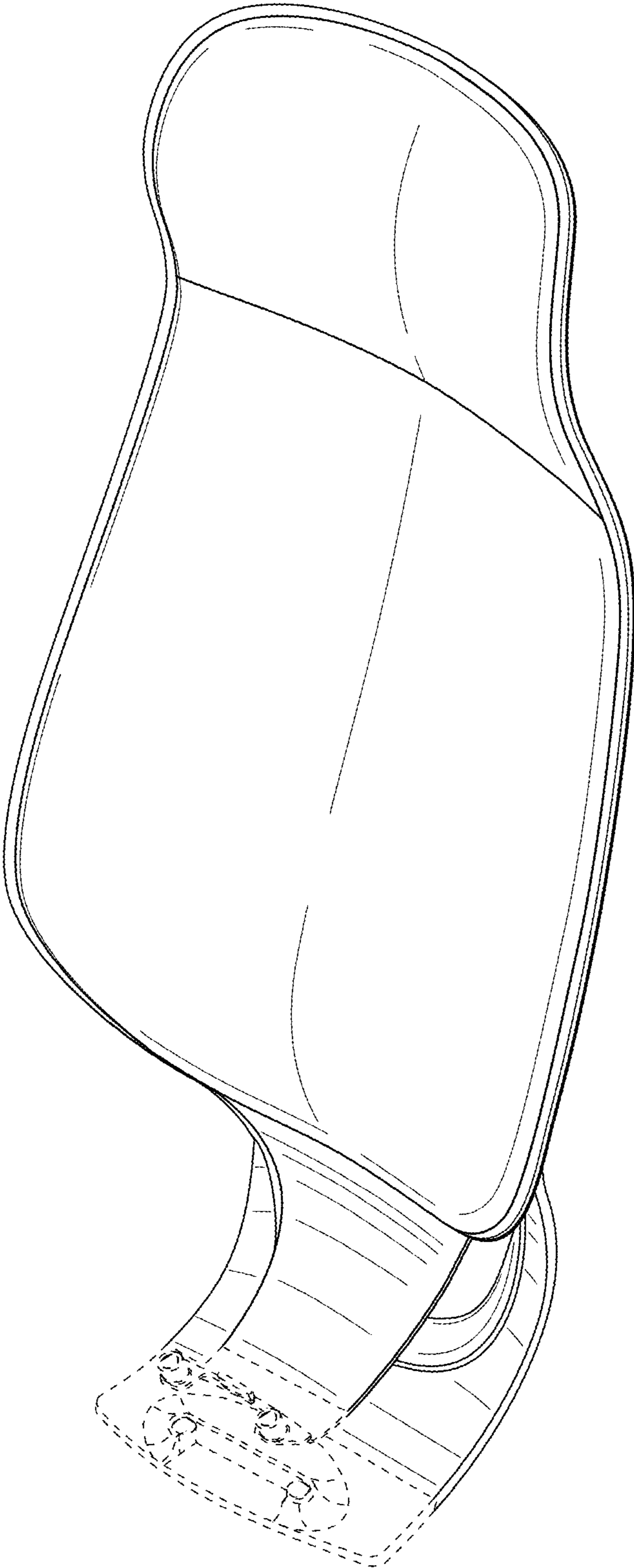
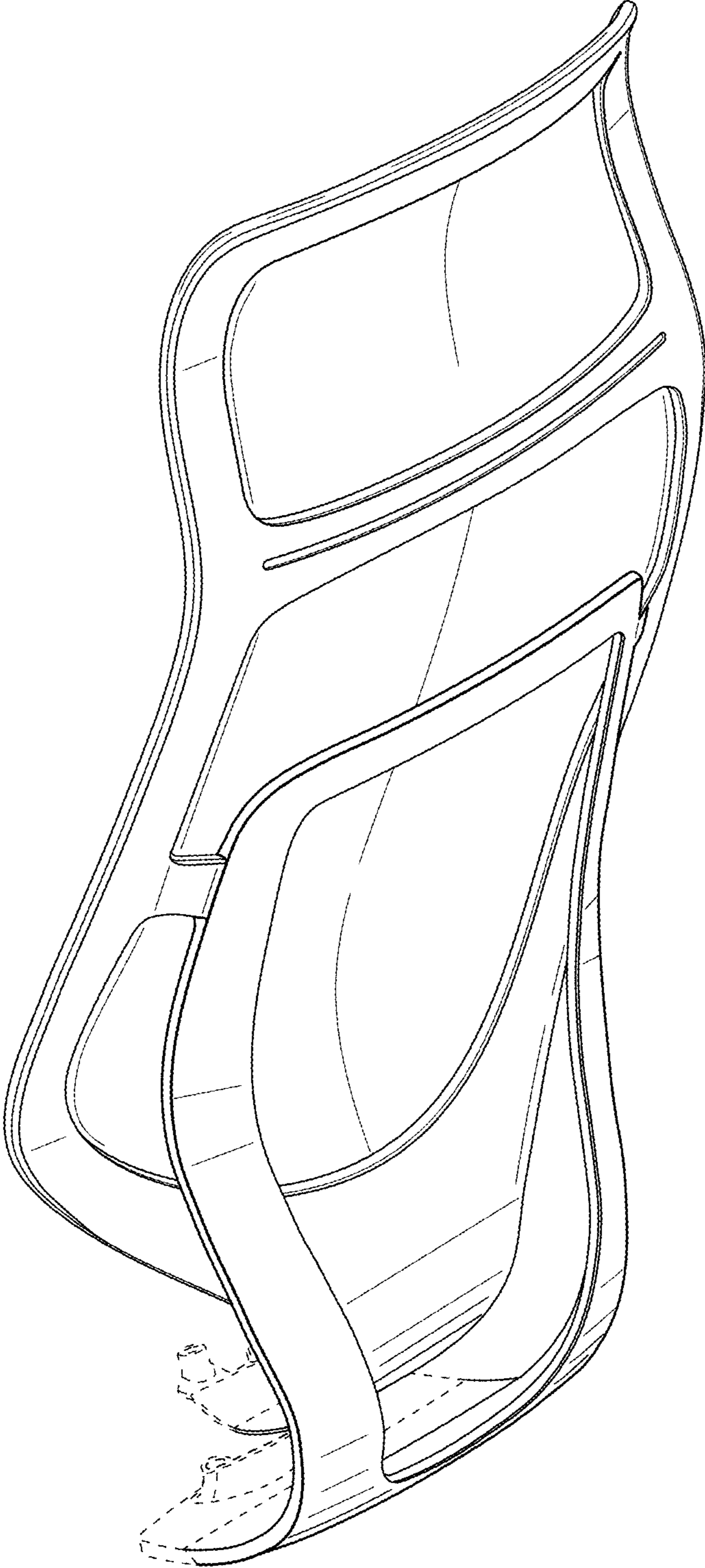
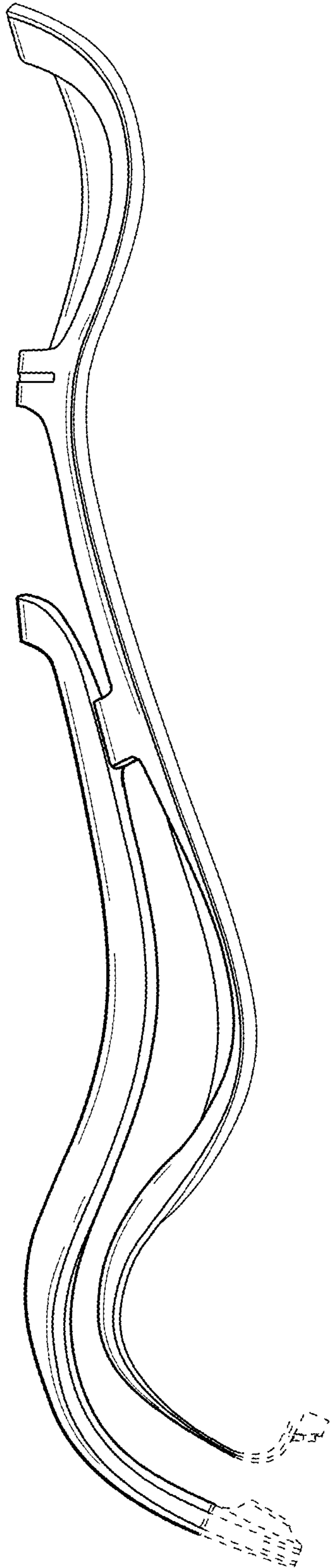

FIG. 2



**FIG. 3**



**FIG. 4**

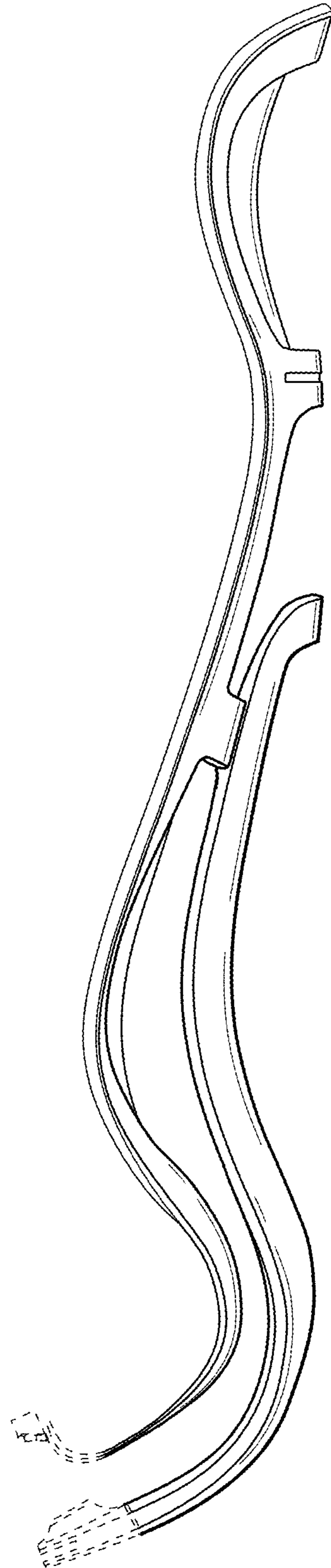

FIG. 5

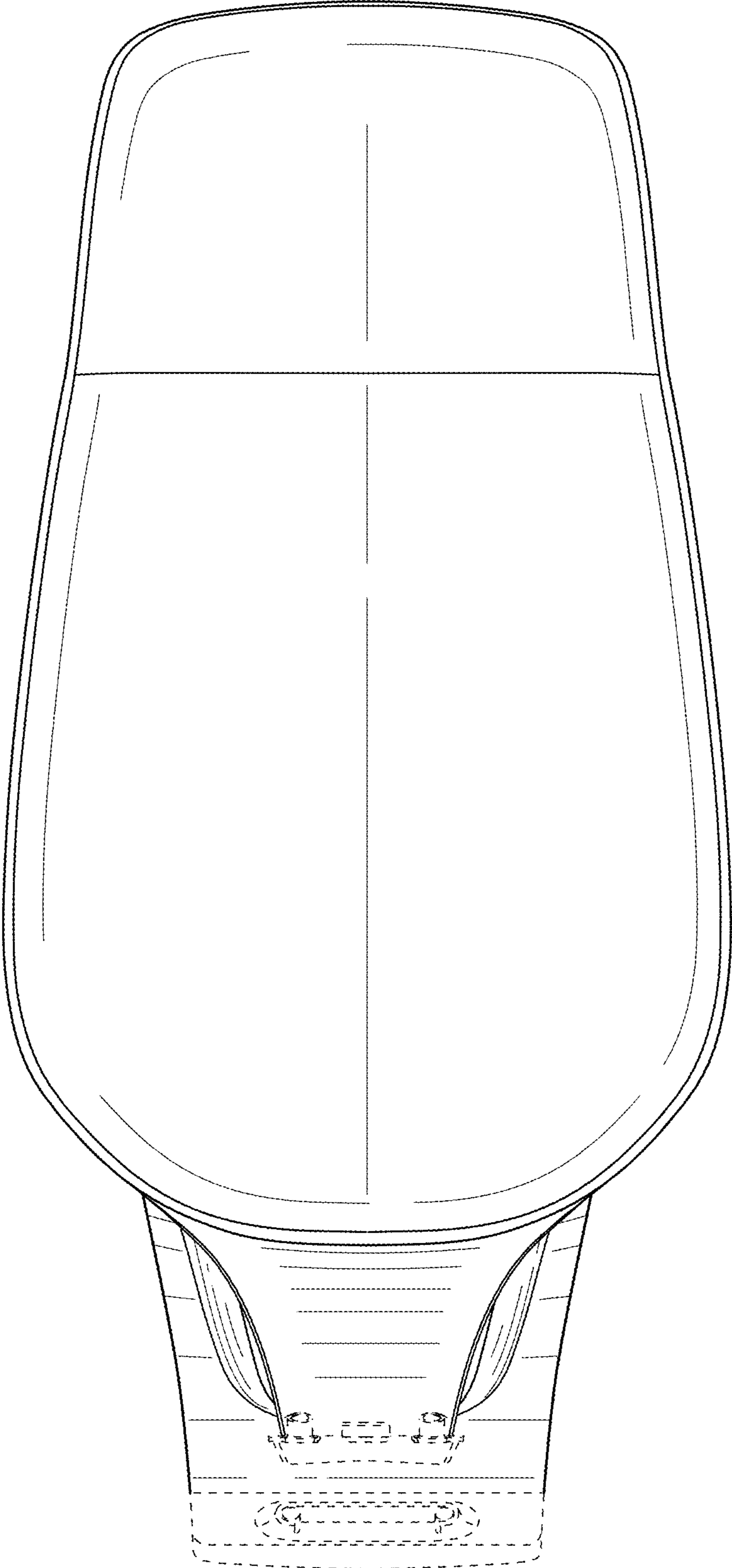

FIG. 6

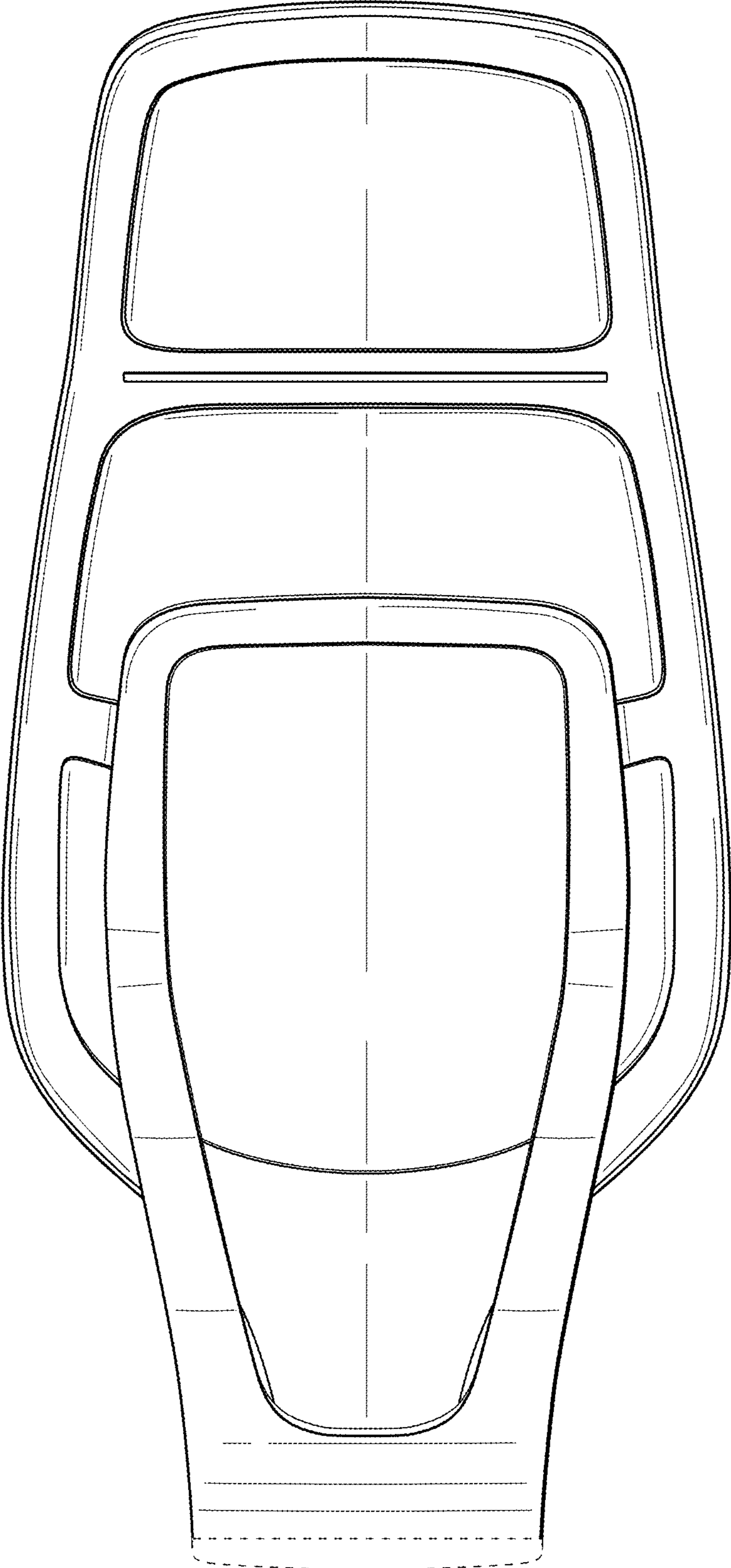

FIG. 7

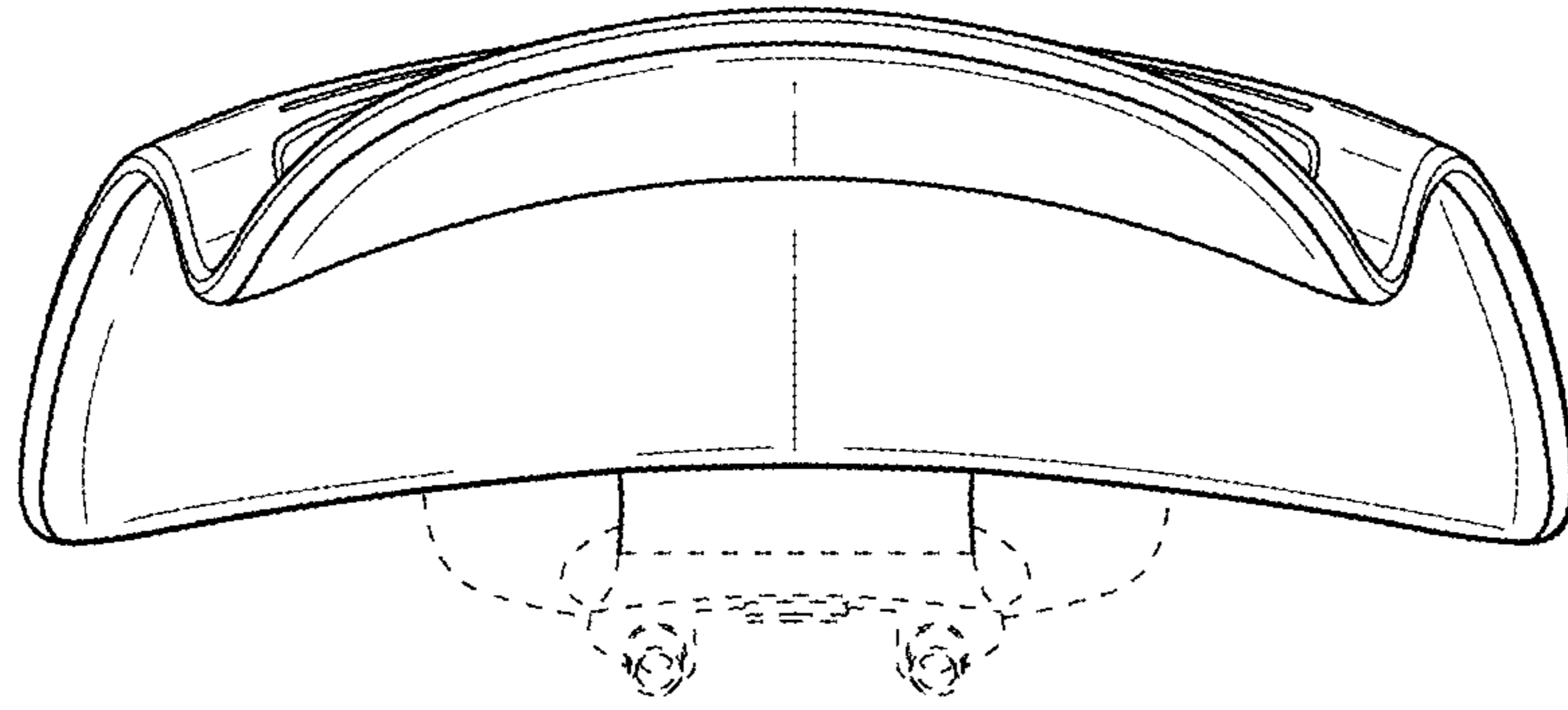

FIG. 8

