



US00D936860S

(12) **United States Design Patent** (10) **Patent No.:** **US D936,860 S**
Styrc et al. (45) **Date of Patent:** **** Nov. 23, 2021**

(54) **CONNECTOR FOR A MODULAR STRUCTURE**

(56) **References Cited**

U.S. PATENT DOCUMENTS

- (71) Applicant: **2724889 ONTARIO INC.**, Oakville (CA)
- (72) Inventors: **Jacek Styrc**, Oakville (CA); **Sebastian Lysiak**, Bielsko-Biala (PL)
- (73) Assignee: **2724889 ONTARIO INC.**, Oakville (CA)
- (**) Term: **15 Years**
- (21) Appl. No.: **29/723,173**
- (22) Filed: **Feb. 5, 2020**

| | | |
|-------------|---------|----------------|
| 451,596 A | 5/1891 | Longnecker |
| 490,122 A | 1/1893 | Magargal |
| 922,215 A | 5/1909 | Tuteur |
| 949,394 A | 2/1910 | Daly |
| 1,097,934 A | 5/1914 | Price |
| 1,201,159 A | 10/1916 | Dettmer |
| 1,214,738 A | 2/1917 | Wolf |
| 1,441,559 A | 1/1923 | Jacob |
| 1,816,049 A | 7/1931 | Larner |
| 1,818,418 A | 8/1931 | Millard |
| 1,848,085 A | 3/1932 | Eisenschmidt |
| 2,016,702 A | 10/1935 | Harry |
| 2,037,736 A | 4/1936 | Payne et al. |
| 2,153,547 A | 4/1939 | Charlop |
| 2,225,599 A | 12/1940 | Zillig |
| D141,423 S | 5/1945 | Lewis |
| 2,477,163 A | 7/1949 | Barnett |
| D178,316 S | 7/1956 | Vegors |
| 2,869,693 A | 1/1959 | Wood |
| 2,931,129 A | 4/1960 | Boniface |
| 3,188,696 A | 6/1965 | Earhart |
| 3,229,004 A | 1/1966 | Lewine |
| 3,278,149 A | 10/1966 | Brucker |
| 3,294,298 A | 12/1966 | Danielson |
| 3,310,324 A | 3/1967 | Boden |
| 3,352,491 A | 11/1967 | Nelson |
| 3,369,333 A | 2/1968 | Wheeler |
| 3,462,021 A | 8/1969 | Hawke |
| 3,537,221 A | 11/1970 | Helfman et al. |
| 3,545,796 A | 12/1970 | Nicholls |
| 3,615,110 A | 10/1971 | Fugate |
| 3,645,569 A | 2/1972 | Reilly |
| 3,740,084 A | 6/1973 | Tellberg |
| D232,201 S | 7/1974 | Hoffman |
| 3,829,999 A | 8/1974 | Bernstein |
| 3,907,445 A | 9/1975 | Wendt |
| 3,945,741 A | 3/1976 | Wendt |
| 3,989,398 A | 11/1976 | Wendt |
| D245,649 S | 9/1977 | Hughes |
| 4,046,186 A | 9/1977 | Nordstrom |
| 4,046,295 A | 9/1977 | Eichler |
| 4,076,431 A | 2/1978 | Burvall |
| D250,240 S | 11/1978 | Braginetz |
| D250,241 S | 11/1978 | Braginetz |
| 4,125,973 A | 11/1978 | Lendrihas |
| 4,125,984 A | 11/1978 | Jonas |
| 4,133,151 A | 1/1979 | Burvall |
| D251,018 S | 2/1979 | Lockwood |
| D258,194 S | 2/1981 | Stanley |

Related U.S. Application Data

- (60) Division of application No. 29/635,278, filed on Jan. 30, 2018, now Pat. No. Des. 887,025, which is a continuation-in-part of application No. 15/815,973, filed on Nov. 17, 2017, now abandoned.
- (51) **LOC (13) Cl.** **25-01**
- (52) **U.S. Cl.**
USPC **D25/133**
- (58) **Field of Classification Search**
USPC D25/119, 125, 126, 127, 128, 129, 130, D25/131, 132, 133, 134, 135, 136; D8/349, 354, 382, 383, 384, 403; D21/468, 471, 478, 479
CPC A47B 47/0008; A47B 47/03; E01B 11/24; E02D 27/42; E04B 1/4157; E04B 1/58; E04B 1/617; E04B 2001/4192; E04B 2/56; E04B 2/70; E04B 1/1912; E04B 1/2688; E04B 2001/1963; E04B 2001/199; E04B 2001/1993; E04B 2001/266; E04B 2001/2676; E04B 2001/1984; E04F 13/0823; E04F 10/02; E04G 21/185; E04G 7/02; E04G 7/22; E04H 12/187; E04H 12/2253; F16B 12/40; A45F 3/24; F16M 11/24
See application file for complete search history.

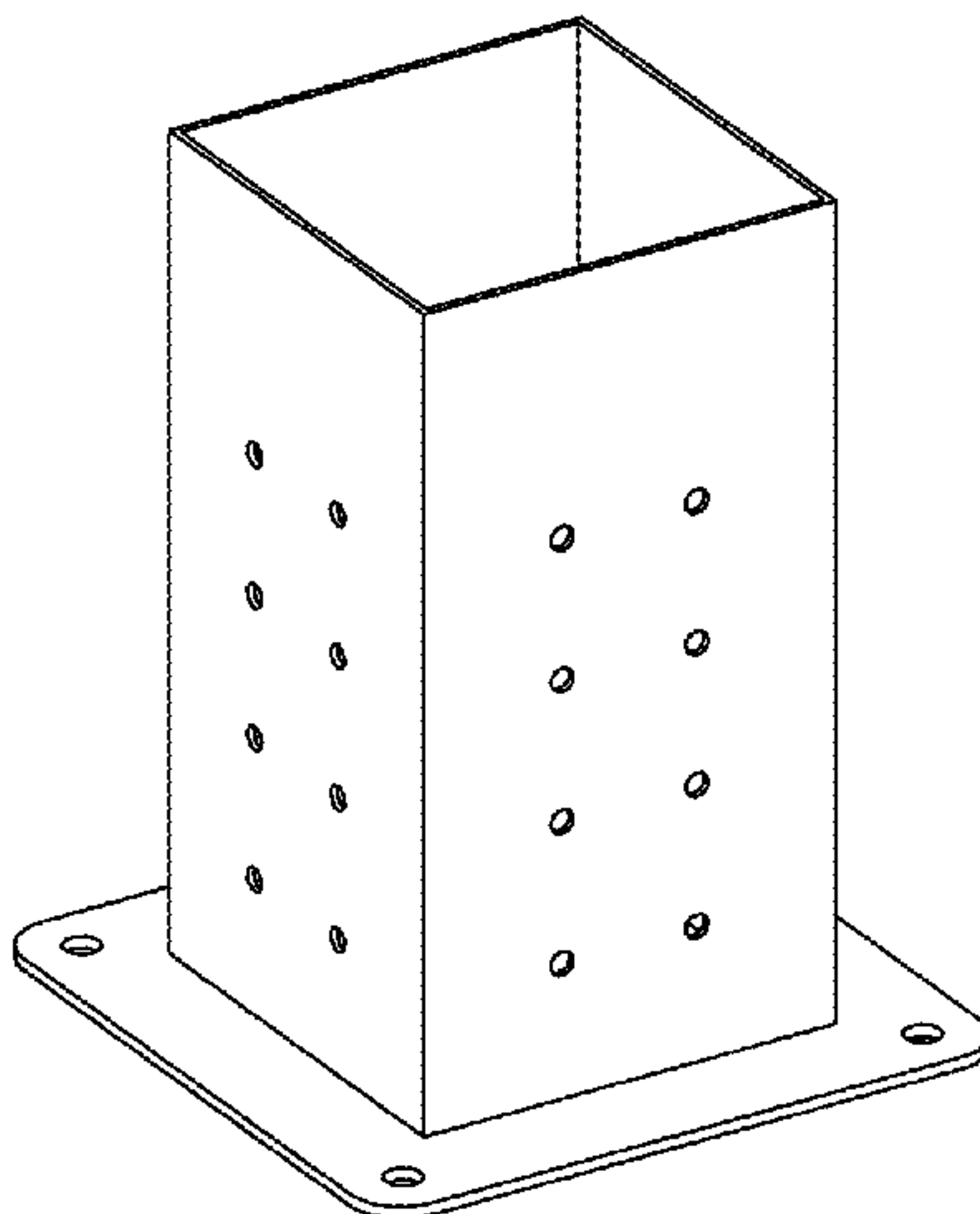

US D936,860 S

| | | | | | |
|--------------|---------|-----------------|---------------|---------|---------------------|
| 4,313,688 A | 2/1982 | Daniels | D558,041 S | 12/2007 | Skinner |
| D264,481 S | 5/1982 | Russo | 7,464,513 B2 | 12/2008 | Rioux |
| 4,381,629 A | 5/1983 | Ahn | D598,734 S | 8/2009 | Miranda et al. |
| 4,422,792 A | 12/1983 | Gilb | 7,600,348 B1 | 10/2009 | Kostka |
| 4,429,730 A | 2/1984 | Elston | D610,717 S | 2/2010 | Lin |
| D275,264 S | 8/1984 | Wegener | D619,879 S | 7/2010 | McCarthy et al. |
| D277,819 S | 3/1985 | Crosslen | 7,762,042 B2 | 7/2010 | Packard |
| D280,466 S | 9/1985 | Seltzer et al. | D622,864 S | 8/2010 | Bajrami |
| 4,572,695 A | 2/1986 | Gilb | D650,987 S | 12/2011 | Rothbauer |
| 4,594,017 A | 6/1986 | Hills | D658,491 S | 5/2012 | Raber |
| 4,616,950 A | 10/1986 | Morris | D665,656 S | 8/2012 | Anzelmo |
| 4,630,550 A | 12/1986 | Weitzman | 8,234,826 B1 | 8/2012 | Proffitt |
| D289,605 S | 5/1987 | Lytle | D673,306 S | 12/2012 | Min-Ju |
| 4,665,672 A | 5/1987 | Commins et al. | 8,429,857 B2 | 4/2013 | Melose |
| 4,717,279 A | 1/1988 | Commins | D689,045 S | 9/2013 | Mardas |
| D294,805 S | 3/1988 | Boyer | D689,207 S | 9/2013 | Benet |
| 4,801,121 A | 1/1989 | Zunker | 8,572,905 B1 | 11/2013 | Driggers |
| 4,856,252 A | 8/1989 | Cornell | D701,108 S | 3/2014 | Rodgers |
| 4,885,883 A | 12/1989 | Wright | 8,689,494 B2 | 4/2014 | Leavitt |
| 4,910,939 A | 3/1990 | Cavanagh | 8,720,129 B2 | 5/2014 | Sias et al. |
| 4,919,394 A | 4/1990 | Otte et al. | 8,739,476 B1 | 6/2014 | Royer |
| 4,925,141 A | 5/1990 | Classen | 8,769,887 B2 | 7/2014 | Proffitt |
| D310,760 S | 9/1990 | Murphy | 8,870,163 B2 | 10/2014 | Regan |
| 4,991,726 A | 2/1991 | Johnson | 8,925,893 B2 | 1/2015 | Biedenweg et al. |
| D318,569 S | 7/1991 | Schaefer | D726,342 S | 4/2015 | Rodriguez |
| 5,033,901 A | 7/1991 | Dias | D727,143 S | 4/2015 | Gomez |
| 5,104,252 A | 4/1992 | Colonias et al. | 9,091,037 B2 | 7/2015 | Fairbairn |
| 5,150,982 A | 9/1992 | Gilb | 9,102,092 B2 | 8/2015 | Mukith et al. |
| 5,186,571 A | 2/1993 | Hentzschel | D737,670 S | 9/2015 | Beyerle et al. |
| 5,192,056 A | 3/1993 | Espinueva | 9,144,291 B2 | 9/2015 | Huang |
| 5,238,321 A | 8/1993 | Jarjoura | D744,319 S | 12/2015 | White |
| 5,259,685 A | 11/1993 | Gilb | 9,228,338 B2 | 1/2016 | Lin |
| D342,328 S | 12/1993 | Granstrom | D749,597 S | 2/2016 | Wengreen |
| D342,662 S | 12/1993 | Lavin, Sr. | 9,388,540 B2 | 7/2016 | Koering |
| 5,284,311 A | 2/1994 | Baer | D768,466 S | 10/2016 | Simmons et al. |
| 5,375,384 A | 12/1994 | Wolfson | D769,470 S | 10/2016 | Criscione et al. |
| D355,349 S | 2/1995 | Taparuskas | D775,512 S | 1/2017 | White |
| D356,646 S | 3/1995 | Cole | D776,965 S | 1/2017 | Anderson |
| RE34,892 E | 4/1995 | Dunwoodie | D783,390 S | 4/2017 | Nelson |
| D361,462 S | 8/1995 | Newham | 9,631,770 B2 | 4/2017 | Holestine |
| D365,714 S | 1/1996 | Masello | D805,218 S | 12/2017 | Malone |
| 5,490,523 A | 2/1996 | Mallookis | 9,856,640 B2 | 1/2018 | Shuhaibar |
| D370,681 S | 6/1996 | Diamond | D820,359 S | 6/2018 | Deemer |
| 5,555,681 A | 9/1996 | Cawthorn | D822,454 S | 7/2018 | Kanter |
| 5,556,218 A | 9/1996 | Homer | D824,399 S | 7/2018 | Wengreen |
| D374,937 S | 10/1996 | Salas | 10,024,046 B2 | 7/2018 | Higginbotham |
| 5,590,974 A | 1/1997 | Yang | 10,030,408 B2 | 7/2018 | Crandall et al. |
| D398,219 S | 9/1998 | Campman | D825,967 S | 8/2018 | Tolokan et al. |
| 5,941,183 A | 8/1999 | Ming-Shun | D826,695 S | 8/2018 | Bolster |
| 5,941,527 A | 8/1999 | Selton | D827,414 S | 9/2018 | MacDonald et al. |
| D426,041 S | 5/2000 | Boghossian | D832,858 S | 11/2018 | Wengreen |
| D427,810 S | 7/2000 | Ali et al. | D834,396 S | 11/2018 | MacDonald |
| 6,092,342 A | 7/2000 | Sharapata | D835,973 S | 12/2018 | Bertato |
| 6,109,461 A | 8/2000 | Kluge et al. | 10,202,766 B1 | 2/2019 | Fox |
| D430,789 S | 9/2000 | Opperman | D842,684 S | 3/2019 | House |
| D434,880 S | 12/2000 | McNary et al. | D843,823 S | 3/2019 | Bouchard |
| D439,246 S | 3/2001 | Hansen | D843,932 S | 3/2019 | Sinai et al. |
| D442,236 S | 5/2001 | Chang | D845,113 S | 4/2019 | Salter |
| 6,230,466 B1 | 5/2001 | Pryor | D845,116 S | 4/2019 | Wokutch |
| 6,247,869 B1 | 6/2001 | Lichvar | D845,310 S | 4/2019 | Wengreen |
| D444,816 S | 7/2001 | Stravitz | D845,959 S | 4/2019 | Wengreen |
| 6,336,620 B1 | 1/2002 | Belli | D846,369 S | 4/2019 | Ni |
| 6,354,451 B1 | 3/2002 | Holst | D846,370 S | 4/2019 | Ni |
| D455,643 S | 4/2002 | Aubin | D852,788 S | 7/2019 | Kanter |
| 6,463,711 B1 | 10/2002 | Callies | D854,191 S | 7/2019 | Sorensen |
| D465,646 S | 11/2002 | Hendrickson | D854,710 S | 7/2019 | Hendry |
| 6,536,179 B2 | 3/2003 | Little | D856,282 S | 8/2019 | Pillsbury |
| 6,636,620 B1 | 10/2003 | Hoshino | D856,781 S | 8/2019 | Hendry et al. |
| D492,040 S | 6/2004 | Kozak | D859,958 S | 9/2019 | Ni |
| 6,745,521 B1 | 6/2004 | Klemming | 10,422,140 B2 | 9/2019 | Mitchell |
| 6,751,921 B1 | 6/2004 | Iwakawa | D866,465 S | 11/2019 | Harrison |
| D493,091 S | 7/2004 | Griggy | 10,480,177 B2 | 11/2019 | Siddhartha et al. |
| D508,572 S | 8/2005 | Suggate | D870,544 S | 12/2019 | Lai et al. |
| 6,969,211 B2 | 11/2005 | Altman | 10,518,596 B2 | 12/2019 | Aitoh et al. |
| 7,014,383 B2 | 3/2006 | Schmid et al. | 10,597,899 B2 | 3/2020 | Crandall et al. |
| 7,231,954 B2 | 6/2007 | Green | D887,025 S * | 6/2020 | Styrc D25/133 |
| D547,863 S | 7/2007 | Heinsch | 10,697,198 B2 | 6/2020 | Crandall et al. |
| D548,064 S | 8/2007 | Norton | 10,760,298 B2 | 9/2020 | Crandall et al. |
| 7,264,416 B2 | 9/2007 | Kahl | D900,199 S | 10/2020 | Rogers |

| | | | | |
|--------------|-----|---------|--------------------|-------------------------|
| D901,929 | S | 11/2020 | Mccune et al. | |
| D905,067 | S | 12/2020 | Wengreen | |
| D905,068 | S | 12/2020 | Wengreen | |
| D905,069 | S | 12/2020 | Wengreen | |
| D912,496 | S | 3/2021 | Fox | |
| D915,186 | S | 4/2021 | Barker | |
| 10,975,584 | B2 | 4/2021 | Brownmiller et al. | |
| D918,010 | S | 5/2021 | Lynn et al. | |
| D920,728 | S | 6/2021 | Scott | |
| D929,611 | S | 8/2021 | Styrc et al. | |
| 11,098,476 | B2 | 8/2021 | Jin et al. | |
| 2003/0101677 | A1 | 6/2003 | Hewett | |
| 2004/0170471 | A1 | 9/2004 | Wadsworth et al. | |
| 2004/0182430 | A1 | 9/2004 | Seo | |
| 2005/0098772 | A1 | 5/2005 | Fuoco | |
| 2006/0029462 | A1 | 2/2006 | Patberg | |
| 2006/0185706 | A1 | 8/2006 | Slade | |
| 2006/0193687 | A1 | 8/2006 | Ghosh | |
| 2006/0260259 | A1 | 11/2006 | Morse | |
| 2007/0209312 | A1 | 9/2007 | Keys et al. | |
| 2007/0209314 | A1* | 9/2007 | Vaughn | E04C 3/32 52/838 |
| 2007/0261356 | A1* | 11/2007 | Vaughn | F16B 9/02 52/655.1 |
| 2007/0266647 | A1 | 11/2007 | Pedersen et al. | |
| 2008/0110583 | A1 | 5/2008 | Lallemand | |
| 2008/0178551 | A1 | 7/2008 | Porter | |
| 2008/0229678 | A1 | 9/2008 | Goddard | |
| 2011/0179741 | A1 | 7/2011 | Yen | |
| 2011/0258941 | A1 | 10/2011 | Dalo | |
| 2011/0308063 | A1 | 12/2011 | Feeleus | |
| 2013/0036702 | A1 | 2/2013 | Paceti et al. | |
| 2013/0108394 | A1* | 5/2013 | Zhu | F16B 39/22 411/366.1 |
| 2013/0232758 | A1 | 8/2013 | Pond | |
| 2013/0247499 | A1 | 9/2013 | Zimmerman et al. | |
| 2013/0276382 | A1 | 10/2013 | Workman | |
| 2013/0306808 | A1 | 11/2013 | Huang | |
| 2014/0082921 | A1 | 3/2014 | Adams | |
| 2015/0152630 | A1 | 6/2015 | Winter | |
| 2015/0328977 | A1* | 11/2015 | Lueschen | B21D 26/033 180/68.4 |
| 2016/0168840 | A1 | 6/2016 | Monty et al. | |
| 2017/0089059 | A1 | 3/2017 | Farre Berga | |
| 2017/0233996 | A1 | 8/2017 | Abernathy et al. | |
| 2017/0314254 | A1 | 11/2017 | Houghton et al. | |
| 2018/0135295 | A1 | 5/2018 | Bowron | |
| 2018/0135296 | A1 | 5/2018 | Brekke | |
| 2018/0230664 | A1* | 8/2018 | Dominguez | E04H 12/2269 |
| 2018/0238041 | A1 | 8/2018 | Styrc | |
| 2019/0078313 | A1 | 3/2019 | Morgan | |
| 2019/0226201 | A1 | 7/2019 | Nguyen | |
| 2019/0271146 | A1 | 9/2019 | Fox | |
| 2019/0277022 | A1 | 9/2019 | Francis | |
| 2020/0375366 | A1 | 12/2020 | Chen | |

FOREIGN PATENT DOCUMENTS

| | | | |
|----|------------|----|---------|
| CA | 3007687 | A1 | 12/2018 |
| CN | 201542095 | U | 8/2010 |
| EP | 2492408 | A1 | 8/2012 |
| EP | 3456990 | A1 | 3/2019 |
| FR | 2300863 | A1 | 9/1976 |
| FR | 2579720 | A1 | 10/1986 |
| FR | 2991304 | A1 | 12/2013 |
| GB | 122765 | A | 1/1935 |
| GB | 910183 | A | 11/1962 |
| JP | S48-032321 | | 11/1974 |
| JP | S5217102 | U | 2/1977 |
| JP | S58-061816 | | 10/1984 |
| JP | 1997268655 | | 10/1997 |
| JP | S48-32322 | | 12/2011 |
| RU | 73909 | U1 | 6/2008 |
| WO | 201656696 | A1 | 4/2016 |
| WO | 2016178637 | A1 | 11/2016 |
| WO | 2019048362 | | 3/2019 |
| WO | 2021094982 | | 5/2021 |

OTHER PUBLICATIONS

Toja Grid Pergola Shade Kit <https://www.lowes.com/pd/Toja-Grid-Pergola-Shade-Kit/5001171579> Date Unknown.*
 Extended European Search Report for 18757067.6, European Patent Office, dated Jul. 23, 2020.
 International Search Report of the International Searching Authority for PCT/CA2018/050169, Canadian Intellectual Property Office, Lily Truong, Canada, dated Jun. 21, 2018.
 Office action for U.S. Appl. No. 15/815,973, United States Patent & Trademark Office, dated Aug. 15, 2018.
 Office action for U.S. Appl. No. 15/815,973, United States Patent & Trademark Office, dated Mar. 19, 2019.
 Office action for U.S. Appl. No. 16/485,272, United States Patent & Trademark Office, dated Dec. 19, 2019.
 Office action for U.S. Appl. No. 29/635,278, United States Patent & Trademark Office, dated Sep. 17, 2019.
 Office Action for U.S. Appl. No. 15/815,973, United States Patent and Trademark Office, Ford, Gisele D., dated Nov. 17, 2017.
 Written Opinion of the International Searching Authority for PCT/CA2018/050169, Canadian Intellectual Property Office, Lily Truong, Canada, dated Jun. 21, 2018.
 Office action for U.S. Appl. No. 29/635,278, United States Patent & Trademark Office, dated Feb. 14, 2020.
 Pergola CUBIC 3-way corner bracket for 7x7 cm post-beam <https://www.vinuo.com/en/pergola-cubic-way-corner-bracket-for-7x7-94058077.html#reviews> Aug. 1, 2019 (Year: 2019).
 Toja Grid TRIO 2 Pack for 6x6 Wood G0210360-2 <https://www.patioproducts.com/toja-grid-trio-2-pack-for-6x6-wood-g0210360-2.html> Date Unknown.
 Notice of Allowance for U.S. Appl. No. 29/635,278, United States Patent & Trademark Office, dated May 7, 2020.
 Notice of References Cited for U.S. Appl. No. 29/635,278, United States Patent & Trademark Office, dated May 7, 2020.
 “Office Action for JP 2021-002873”.
 “Office Action for JP 2021-002874”.
 “Office Action for JP 2021-002875”.
 “Office Action for JP 2021-002876”.
 “Office Action for JP 2021-002877”.
 “Office Action for JP 2021-002878”.
 “Russian Patent Office, Office Action of Jul. 6, 2021 for application No. 2019128908”.
 Li, Hui, “First Notification of Office Action”, CN patent application 201880024165.9.

* cited by examiner

Primary Examiner — Samantha Q Lawrence
 (74) Attorney, Agent, or Firm — Bhole IP Law; Anil Bhole; Marc Lampert

(57) CLAIM

The ornamental design for a connector for a modular structure, substantially as shown and described.

DESCRIPTION

FIG. 1 is a perspective view of the connector for a modular structure;
 FIG. 2 is a rear elevation of the connector for a modular structure of FIG. 1;
 FIG. 3 is a front elevation of the connector for a modular structure of FIG. 1;
 FIG. 4 is a plan view of the connector for a modular structure of FIG. 1;
 FIG. 5 is a bottom view of the connector for a modular structure of FIG. 1;
 FIG. 6 is a side elevation of the connector for a modular structure of FIG. 1; and

FIG. 7 is a side elevation from the opposite side to FIG. 6 of the connector for a modular structure of FIG. 1;
FIG. 8 is a perspective view of a variant of the connector for a modular structure;
FIG. 9 is a rear elevation of the connector for a modular structure of FIG. 8;
FIG. 10 is a front elevation of the connector for a modular structure of FIG. 8;
FIG. 11 is a plan view of the connector for a modular structure of FIG. 8;
FIG. 12 is a bottom view of the connector for a modular structure of FIG. 8;
FIG. 13 is a side elevation of the connector for a modular structure of FIG. 8; and,
FIG. 14 is a side elevation from the opposite side to FIG. 13 of the connector for a modular structure of FIG. 8.

1 Claim, 14 Drawing Sheets

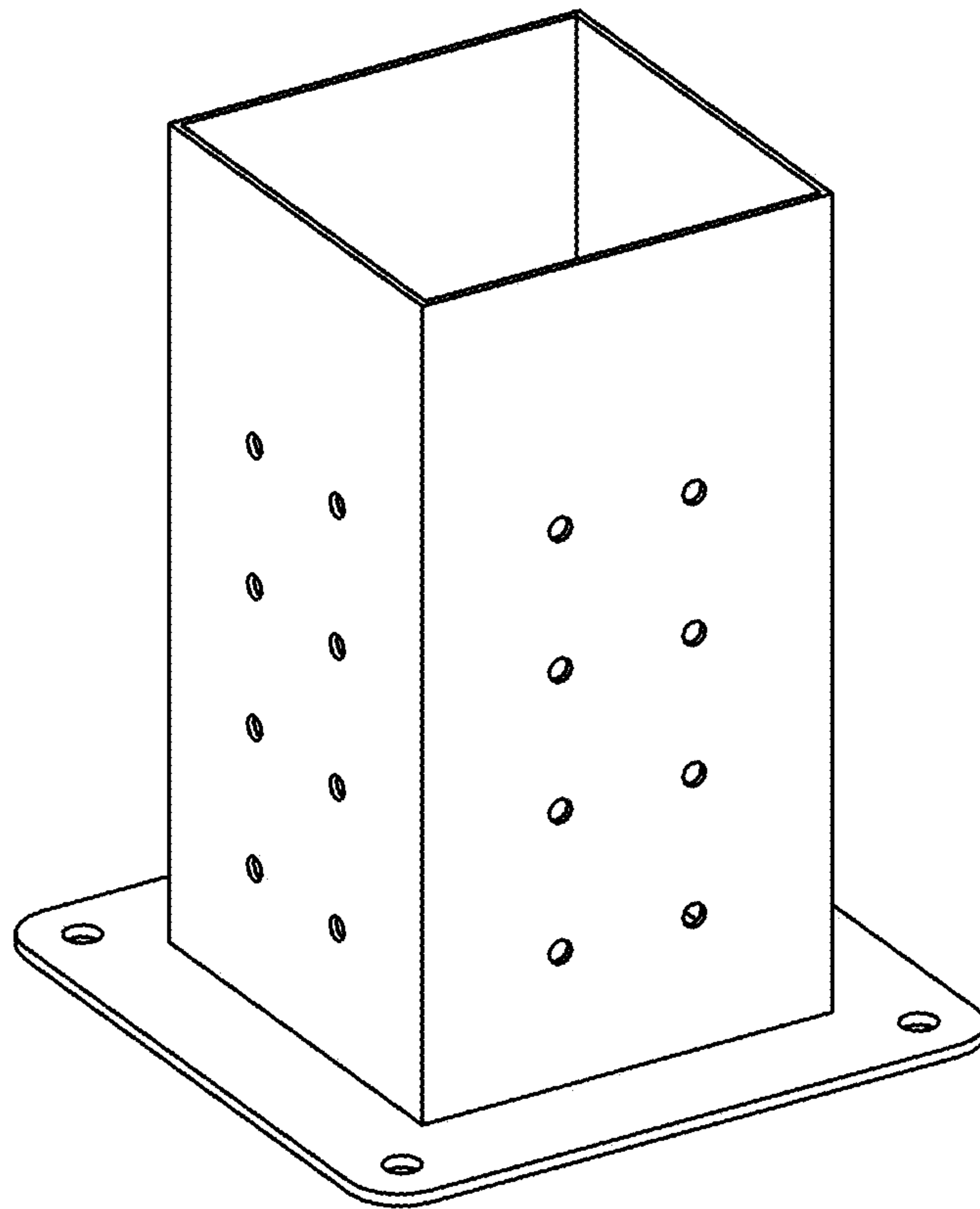

FIG. 1

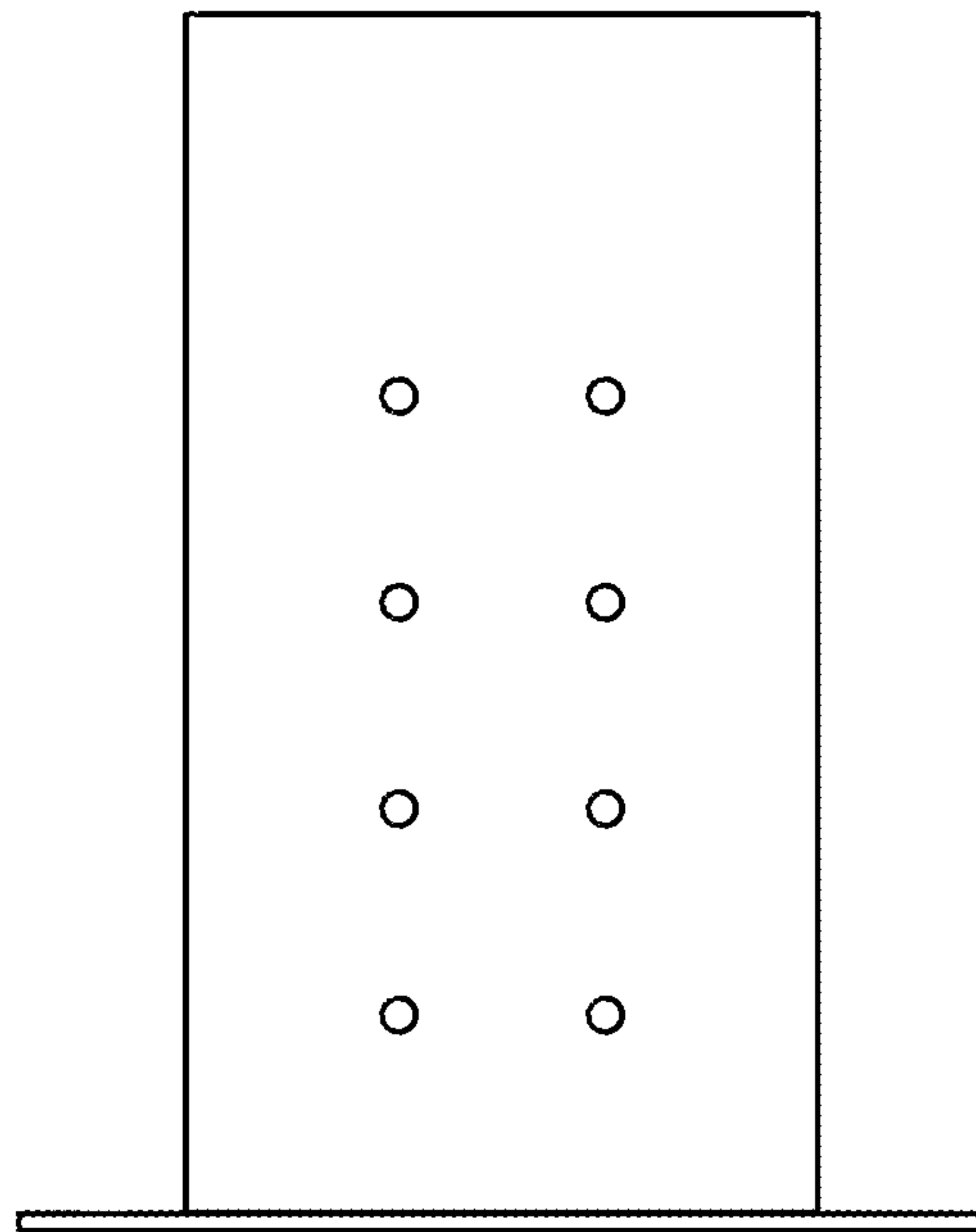

FIG. 2

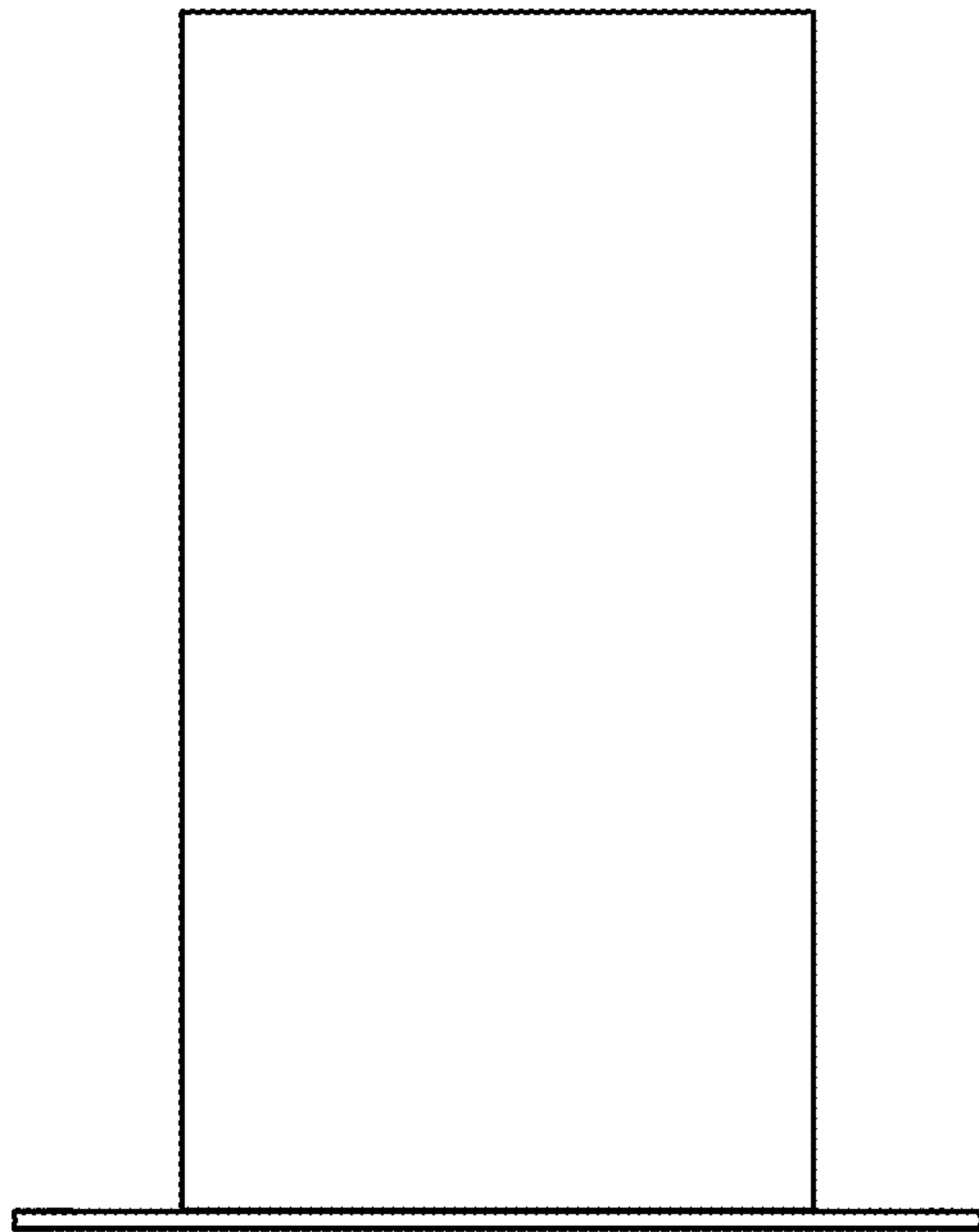

FIG. 3

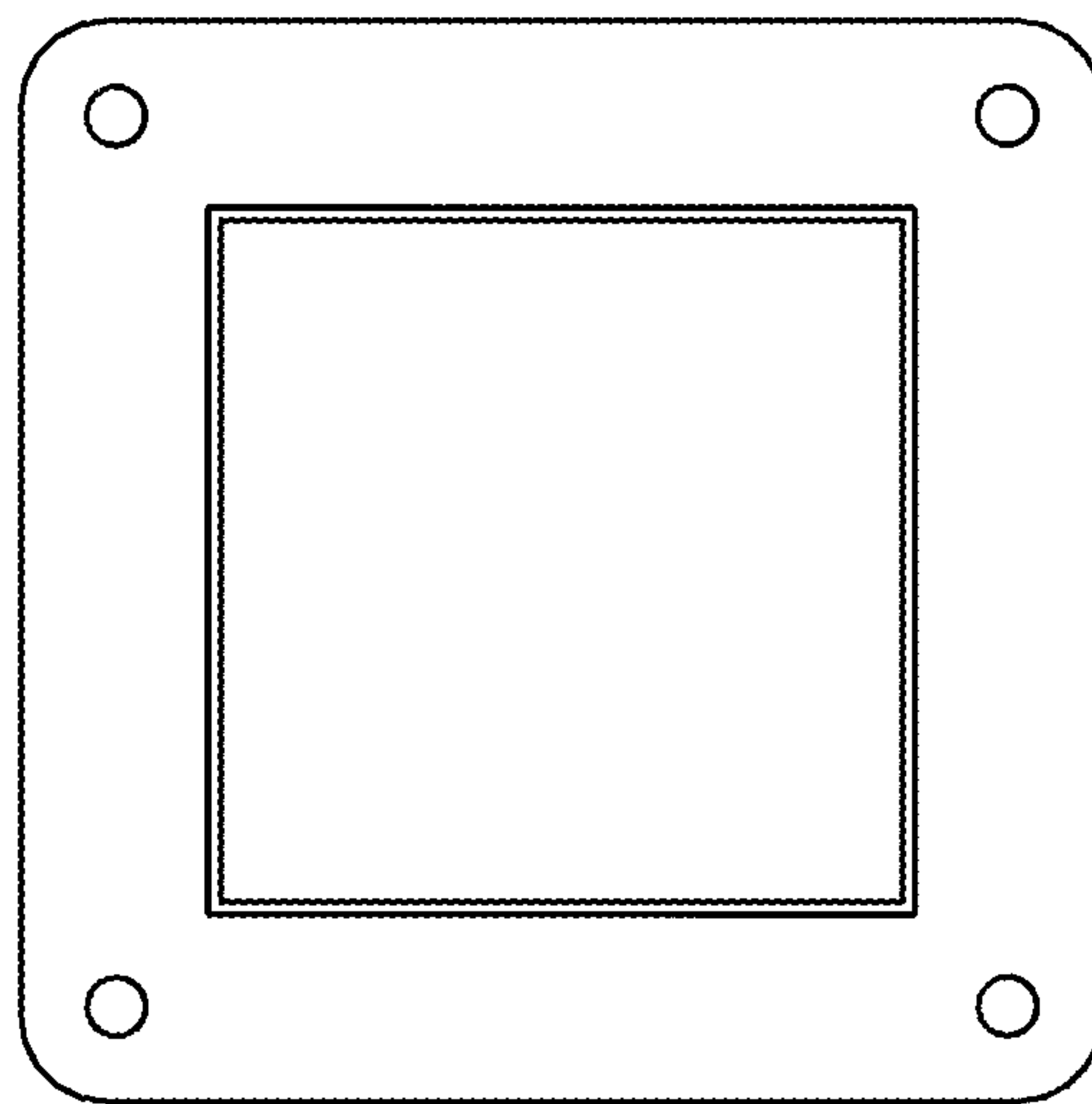

FIG. 4

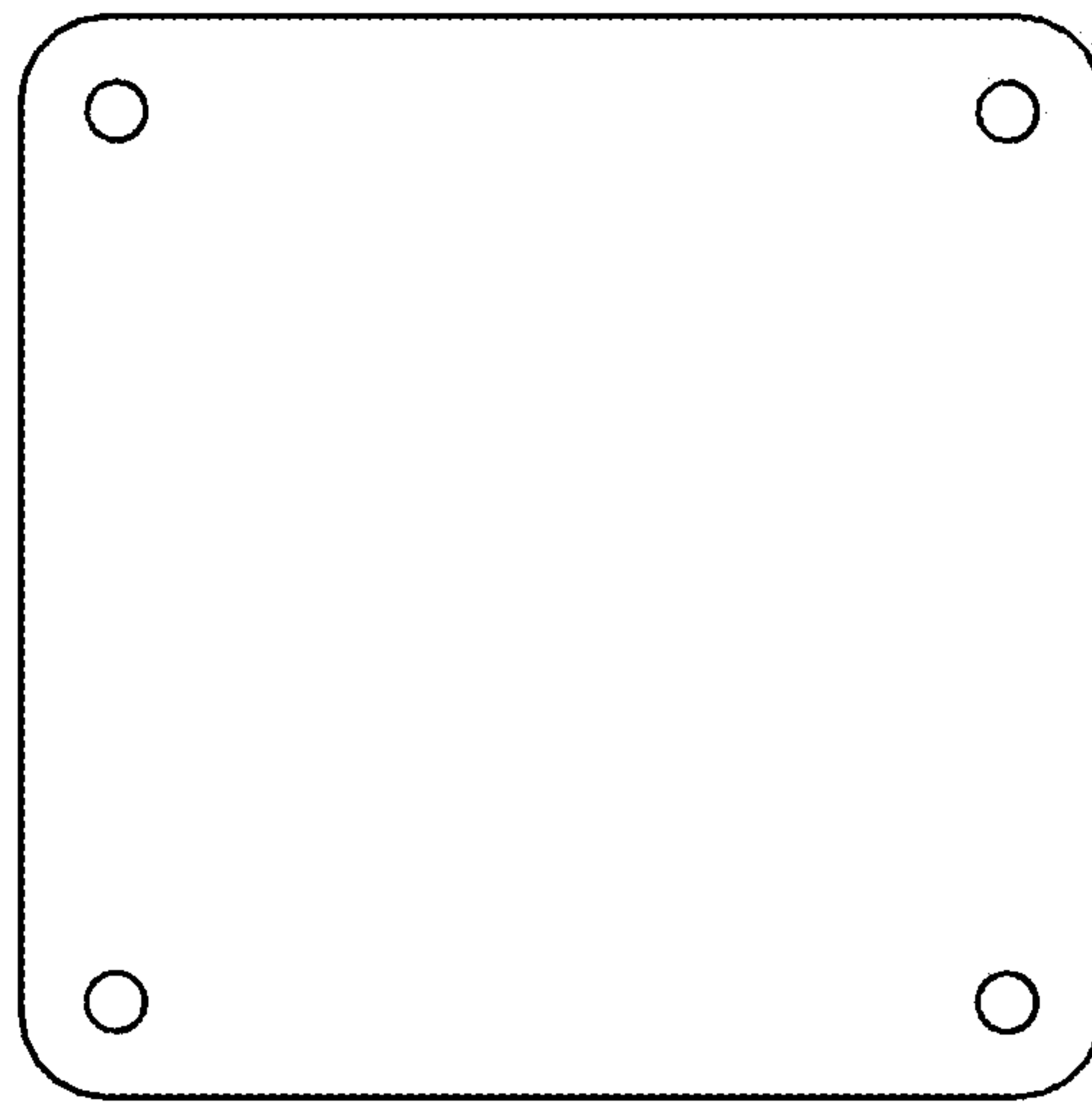

FIG. 5

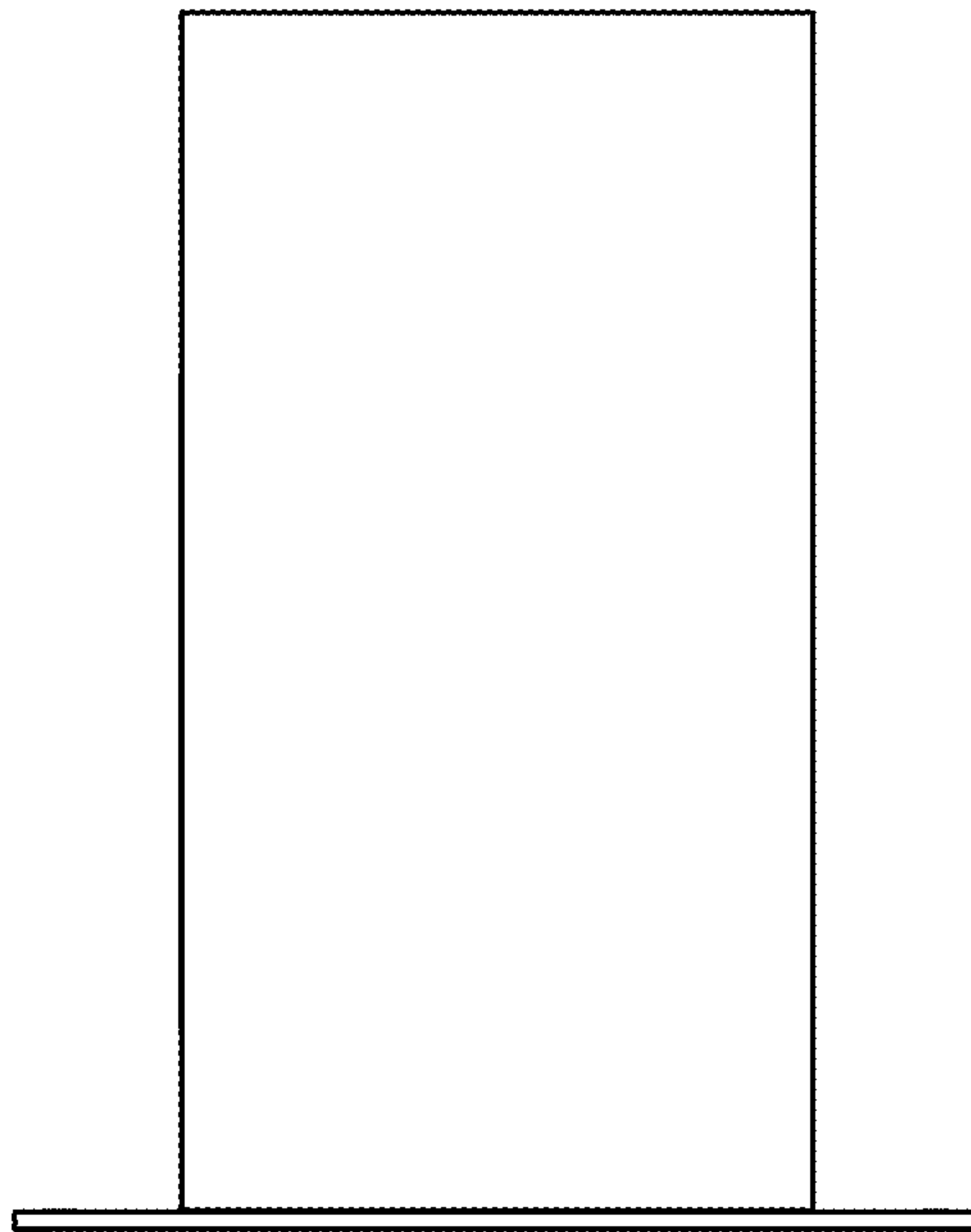

FIG. 6

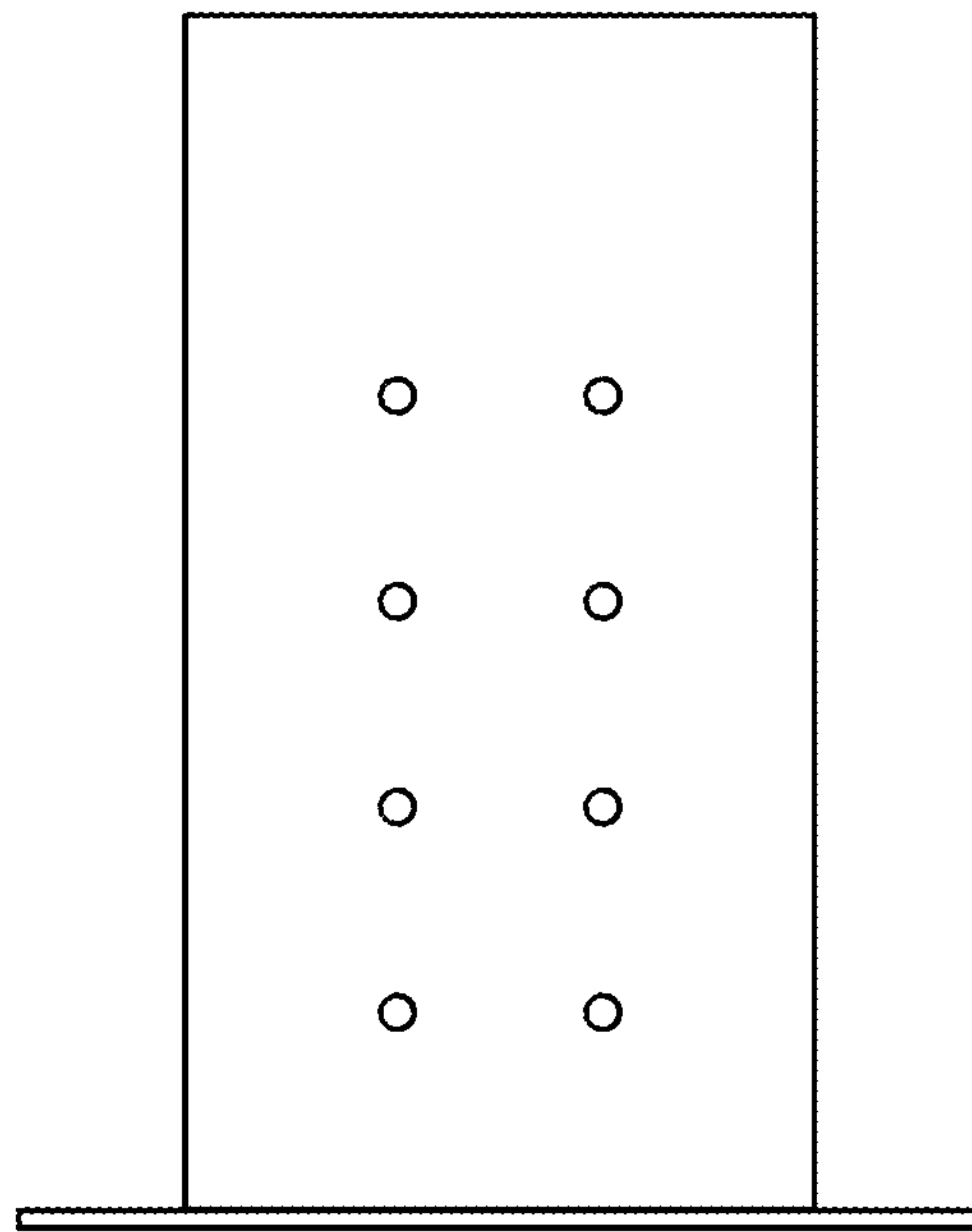

FIG. 7

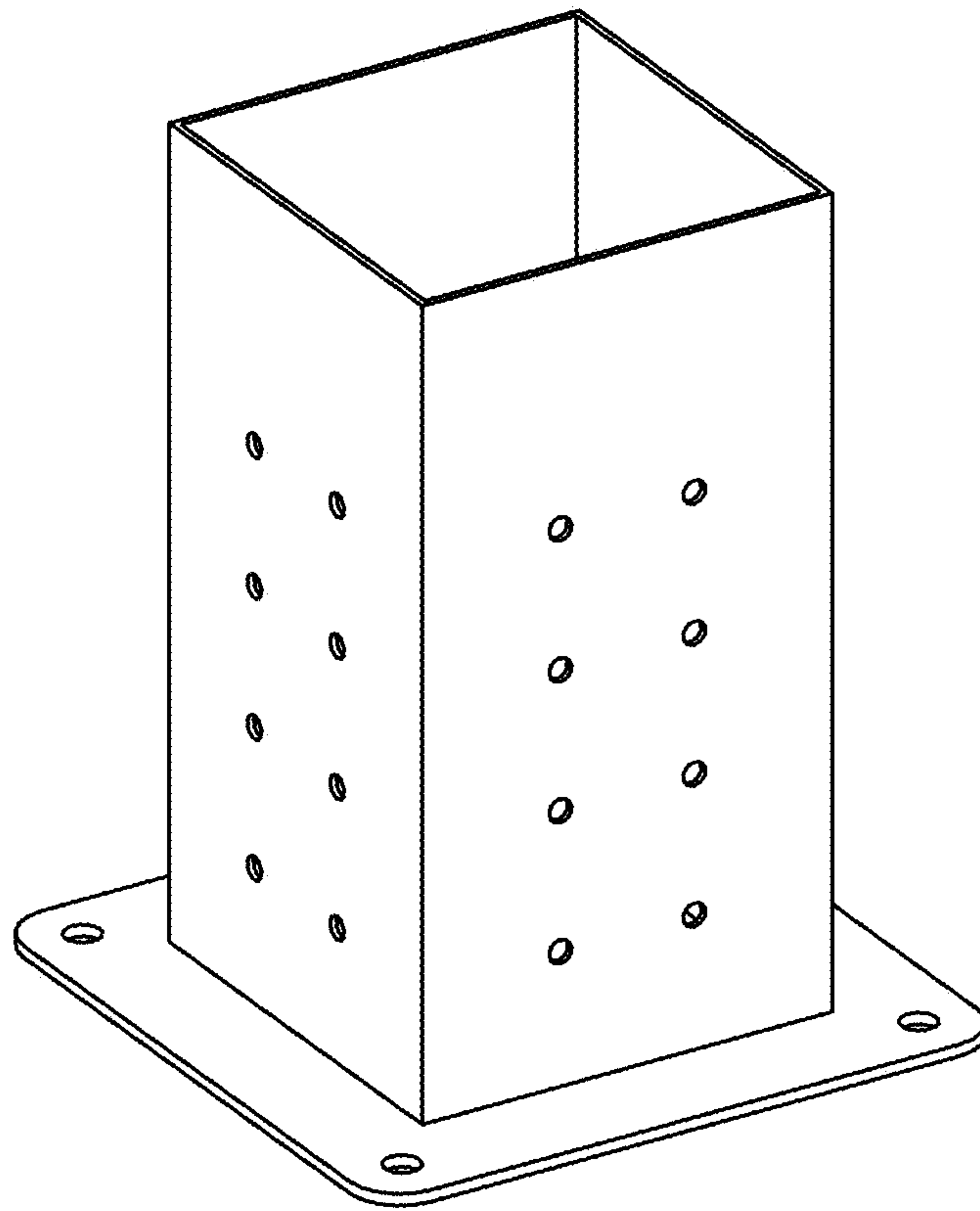

FIG. 8

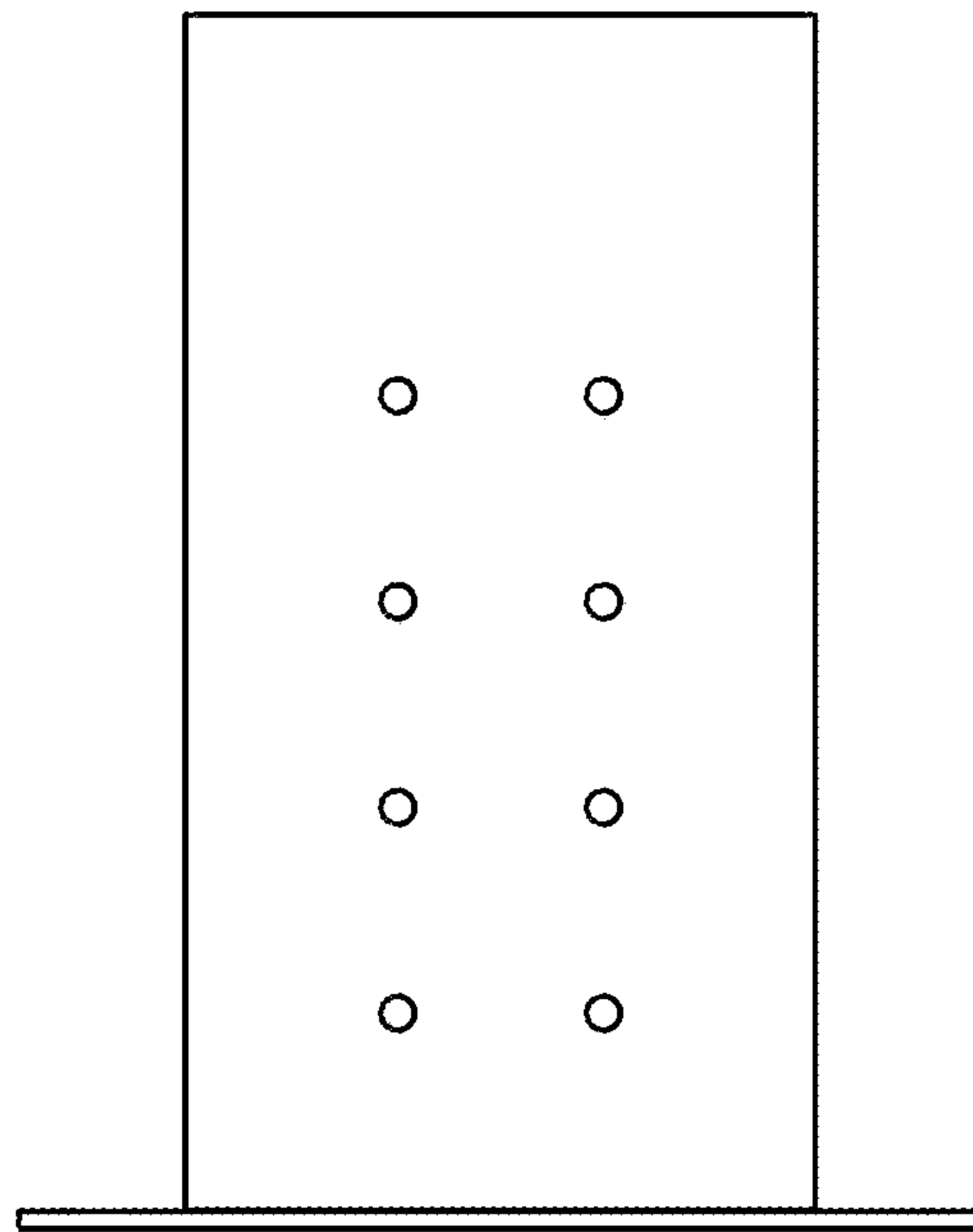

FIG. 9

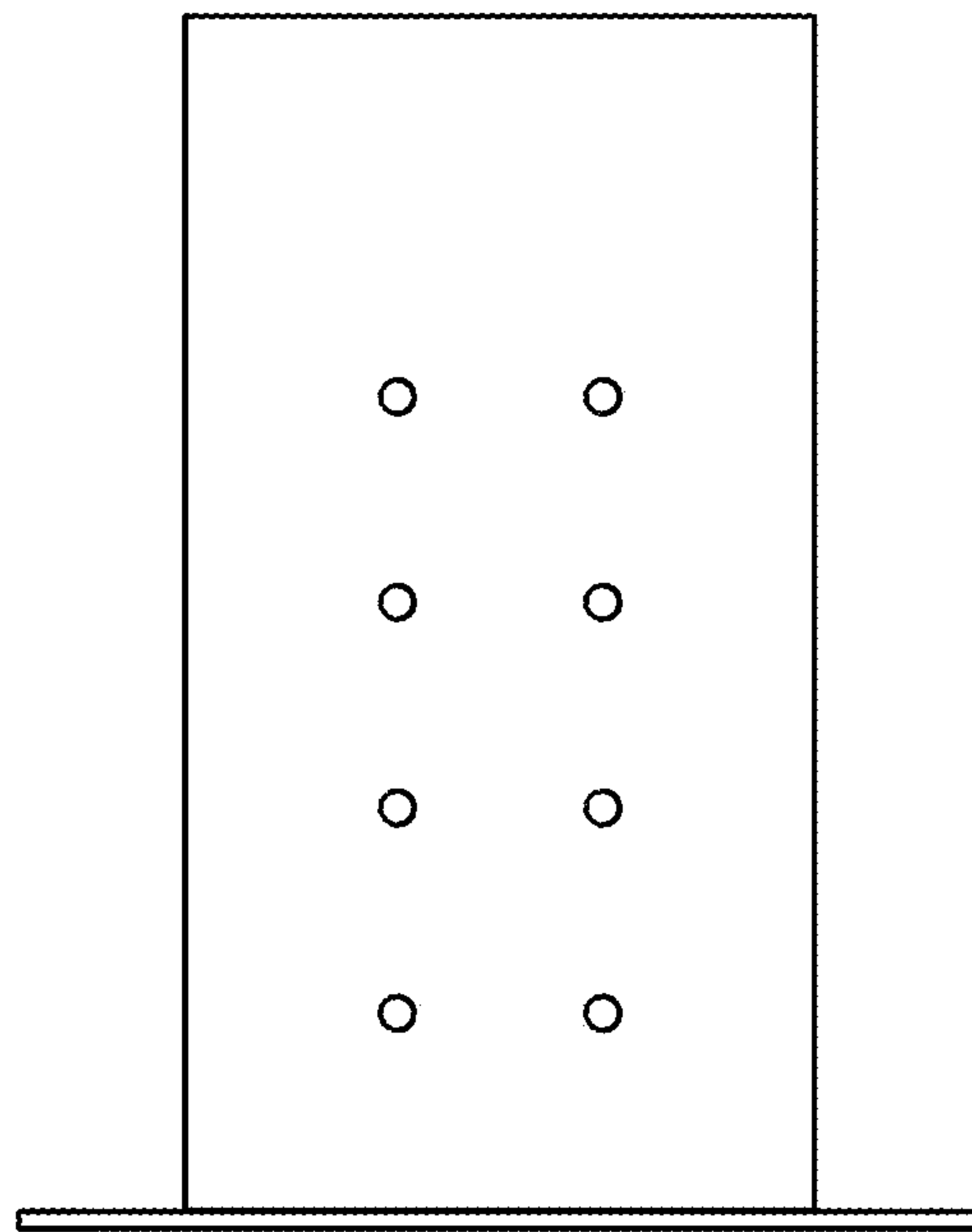

FIG. 10

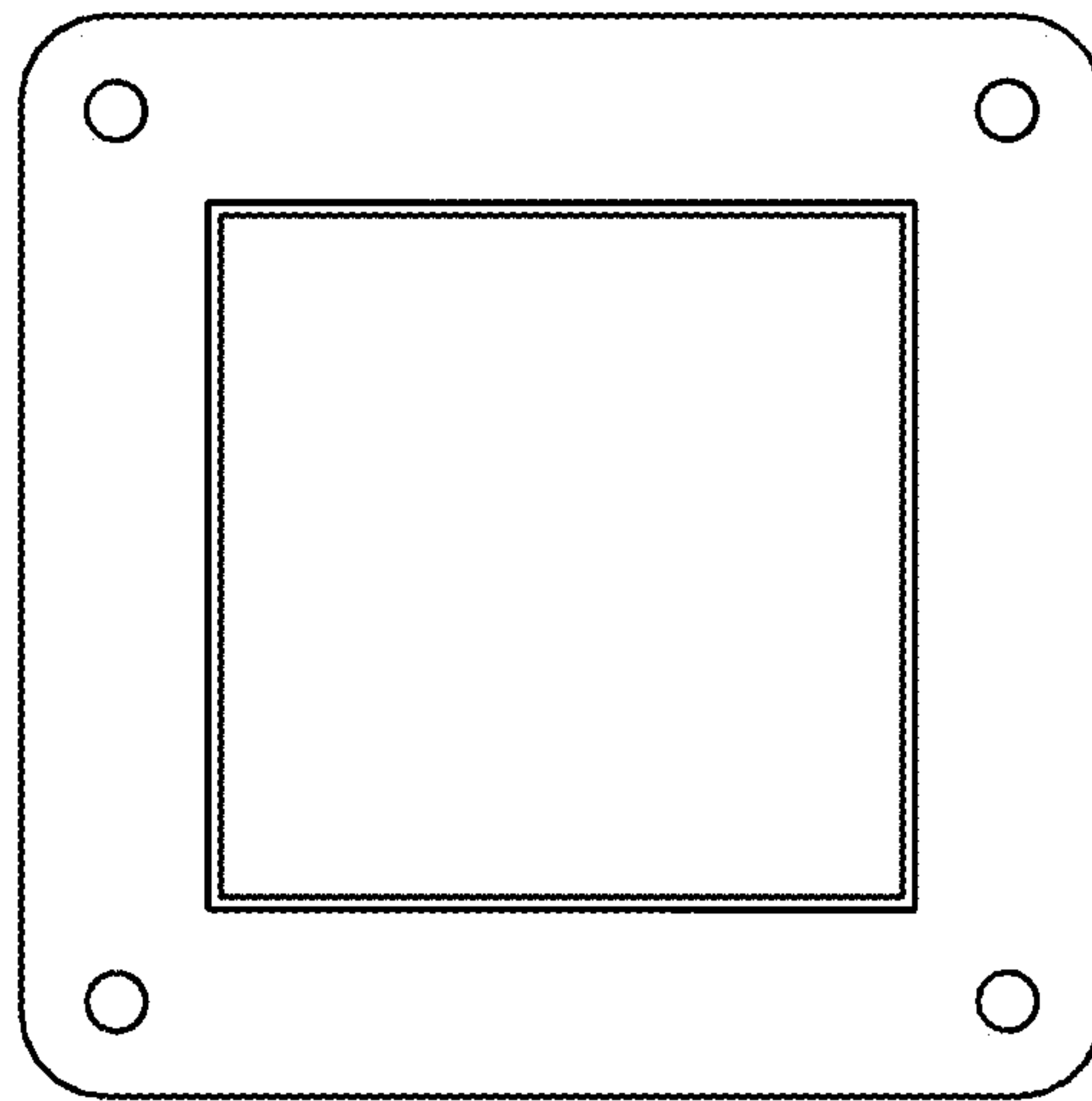

FIG. 11

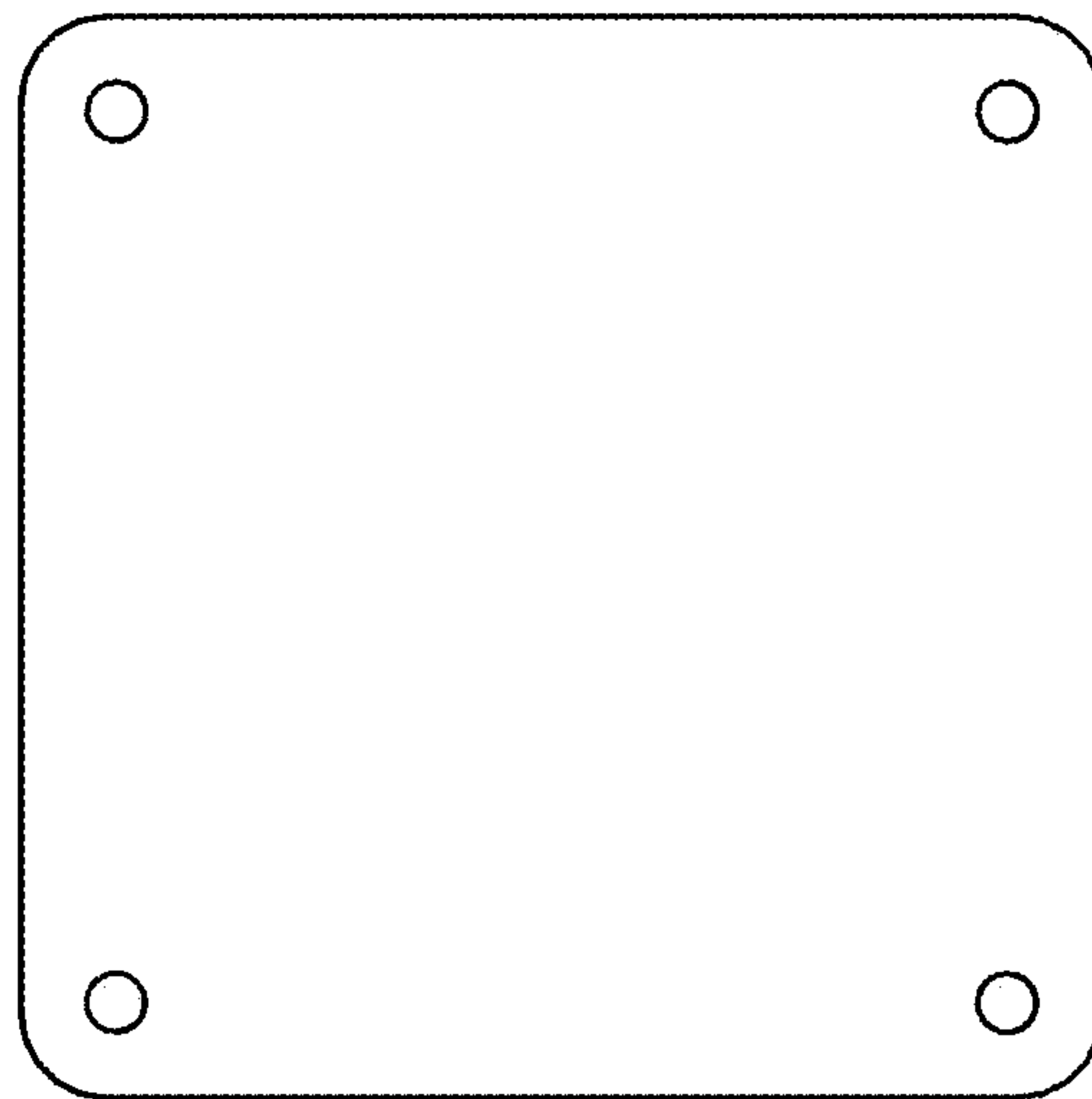

FIG. 12

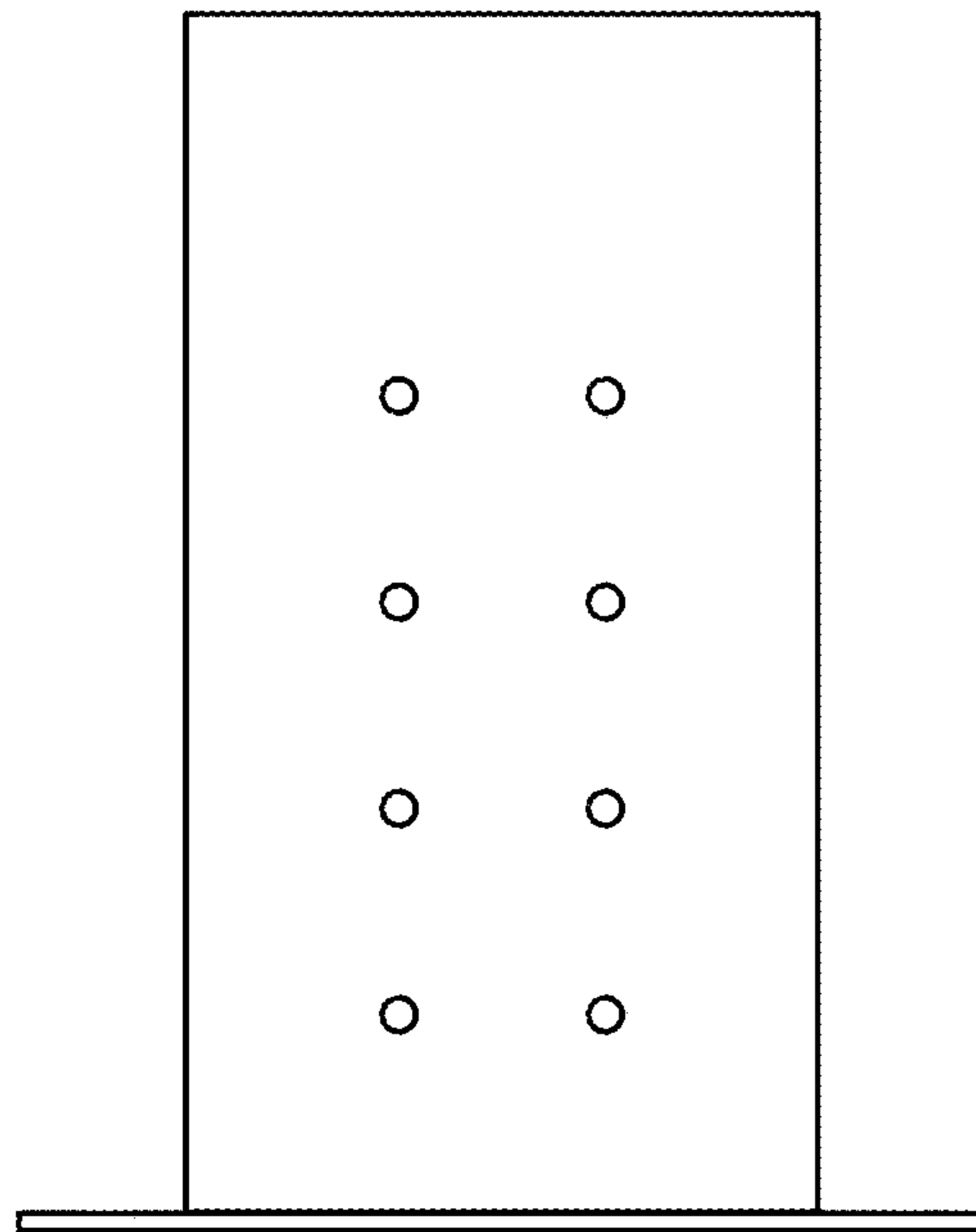

FIG. 13

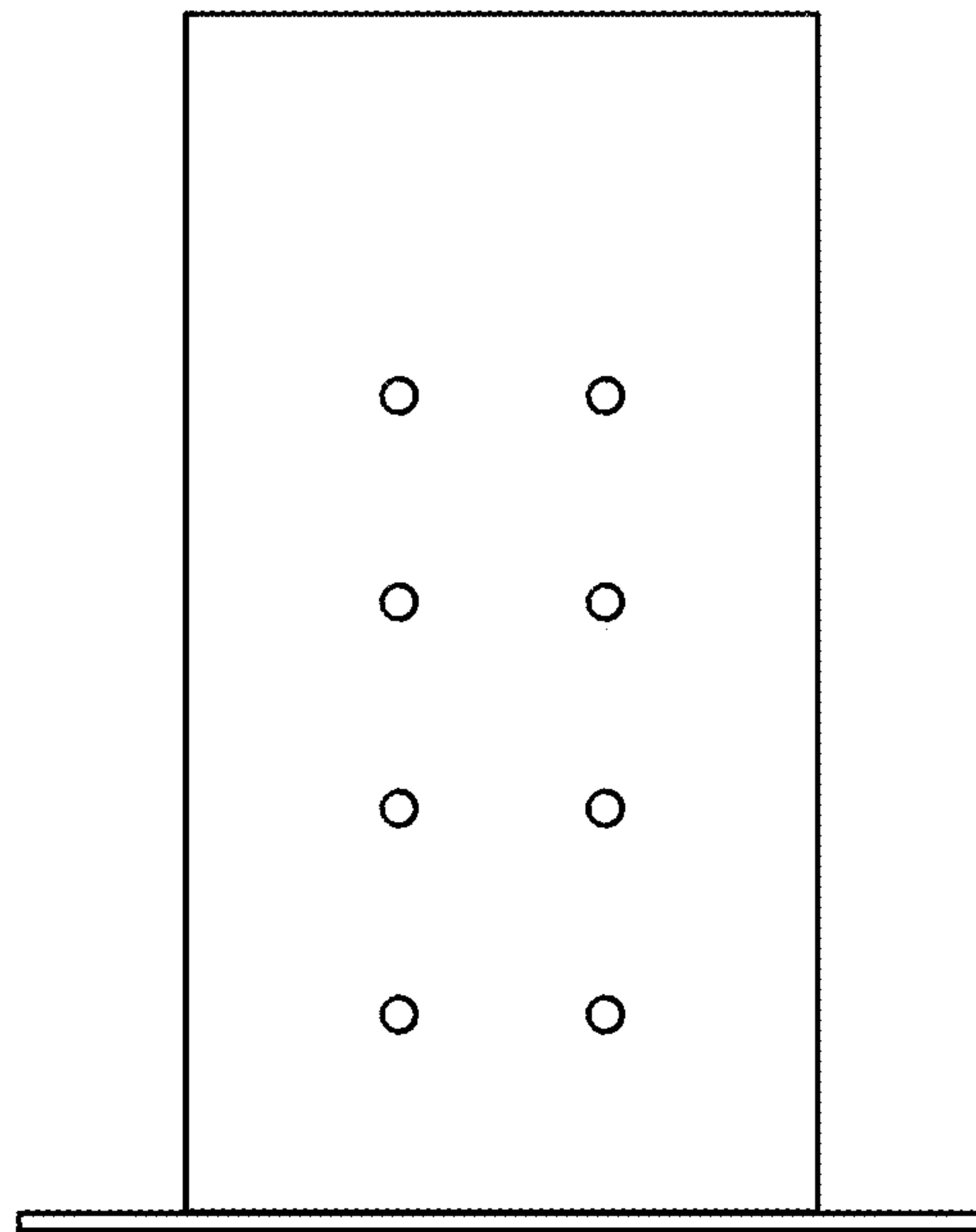

FIG. 14