



US00D935952S

(12) **United States Design Patent** (10) **Patent No.:** **US D935,952 S**
Minetto (45) **Date of Patent:** **** Nov. 16, 2021**

(54) **COUPLING ASSEMBLY FOR A VEHICLE**

D888,617 S * 6/2020 Roysum B60D 1/60
D12/162
D897,245 S * 9/2020 Borkholder D12/162
D904,237 S * 12/2020 Qiu D12/162

(71) Applicant: **Cruisemaster Australia Pty, Ltd,**
Geebung (AU)

* cited by examiner

(72) Inventor: **Brayden James Minetto,** Geebung
(AU)

Primary Examiner — Katrina A Betton

(74) *Attorney, Agent, or Firm* — Dobbin IP Law P.C.

(73) Assignee: **Cruisemaster Australia Pty, Ltd.,**
Geebung (AU)

(57) **CLAIM**

The ornamental design for a coupling assembly for a vehicle, as shown and described.

(**) Term: **15 Years**

DESCRIPTION

(21) Appl. No.: **29/747,257**

FIG. 1 is a top/rear/left perspective view of the coupling assembly for a vehicle.

(22) Filed: **Aug. 20, 2020**

FIG. 2 is a top plan view of the coupling assembly for a vehicle.

(30) **Foreign Application Priority Data**

Feb. 20, 2020 (AU) 202010976

FIG. 3 is a top/rear/right perspective view of the coupling assembly for a vehicle.

(51) **LOC (13) Cl.** **12-16**

FIG. 4 is a left elevation of the coupling assembly for a vehicle.

(52) **U.S. Cl.**

USPC **D12/162**

FIG. 5 is a rear elevation of the coupling assembly for a vehicle.

(58) **Field of Classification Search**

USPC D12/159, 160, 161, 162

FIG. 6 is a right elevation of the coupling assembly for a vehicle.

CPC B62D 33/033; B60D 1/36; B60D 1/06;

B60D 1/00; B60D 1/065; B60D 1/60

See application file for complete search history.

FIG. 7 is a bottom/rear/left perspective view of the coupling assembly for a vehicle.

(56) **References Cited**

U.S. PATENT DOCUMENTS

D800,611 S * 10/2017 Ramirez, Jr. D12/162
D834,464 S * 11/2018 Cincunegui D12/162
D841,526 S * 2/2019 Siegel D12/162
D866,412 S * 11/2019 Williams D12/162
D869,997 S * 12/2019 Borkholder D12/162
D873,723 S * 1/2020 Borkholder D12/162
D876,290 S * 2/2020 Kirkland D12/162

FIG. 8 is a bottom plan view of the coupling assembly for a vehicle.

FIG. 9 is a bottom/rear/right perspective view of the coupling assembly for a vehicle; and,

FIG. 10 is the coupling assembly for a vehicle of FIG. 1, with a socket mounted therein.

The broken lines in figures depict unclaimed structure that is illustrative of environment and not intended to form a part of the claimed design.

1 Claim, 10 Drawing Sheets

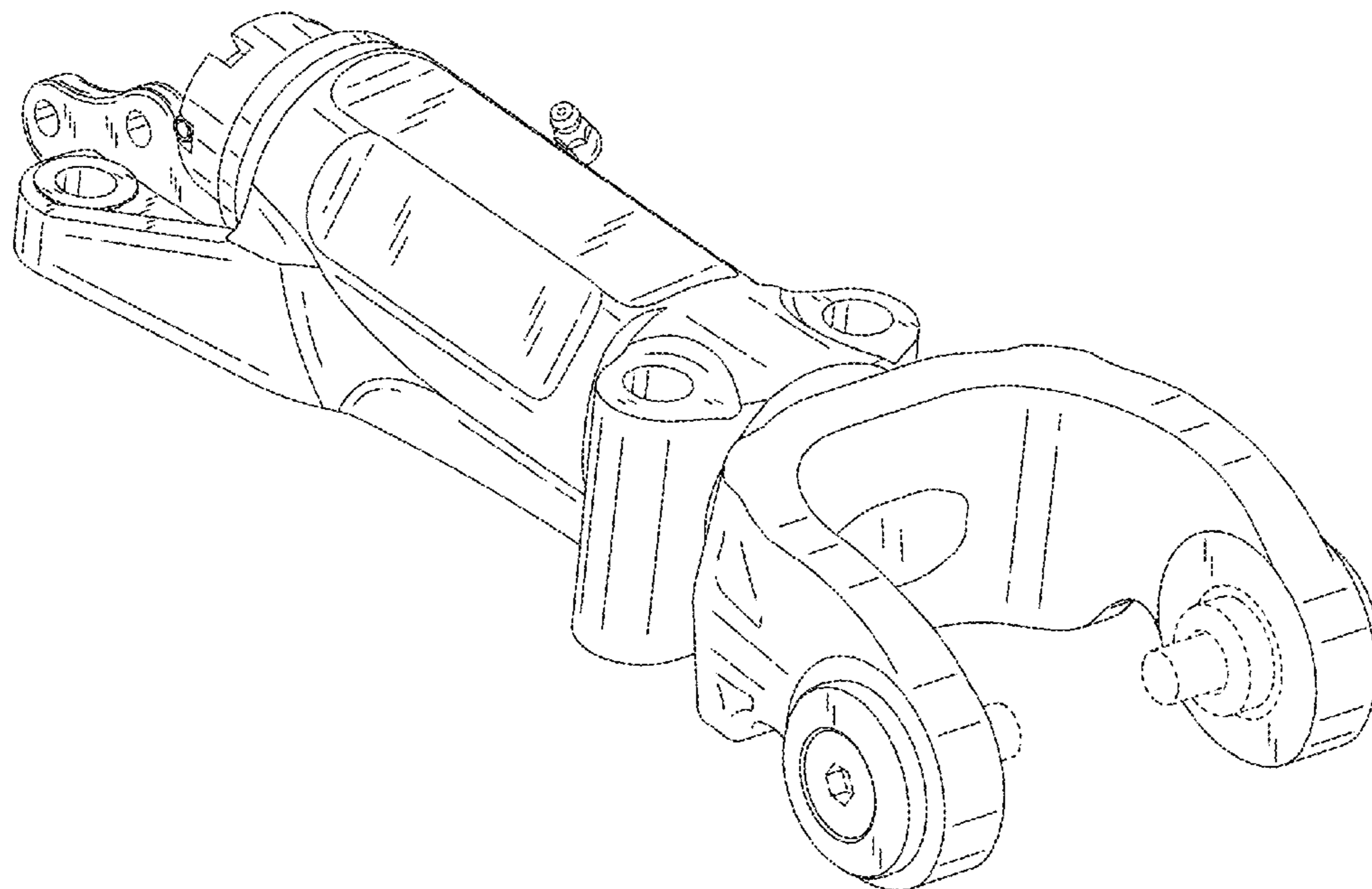

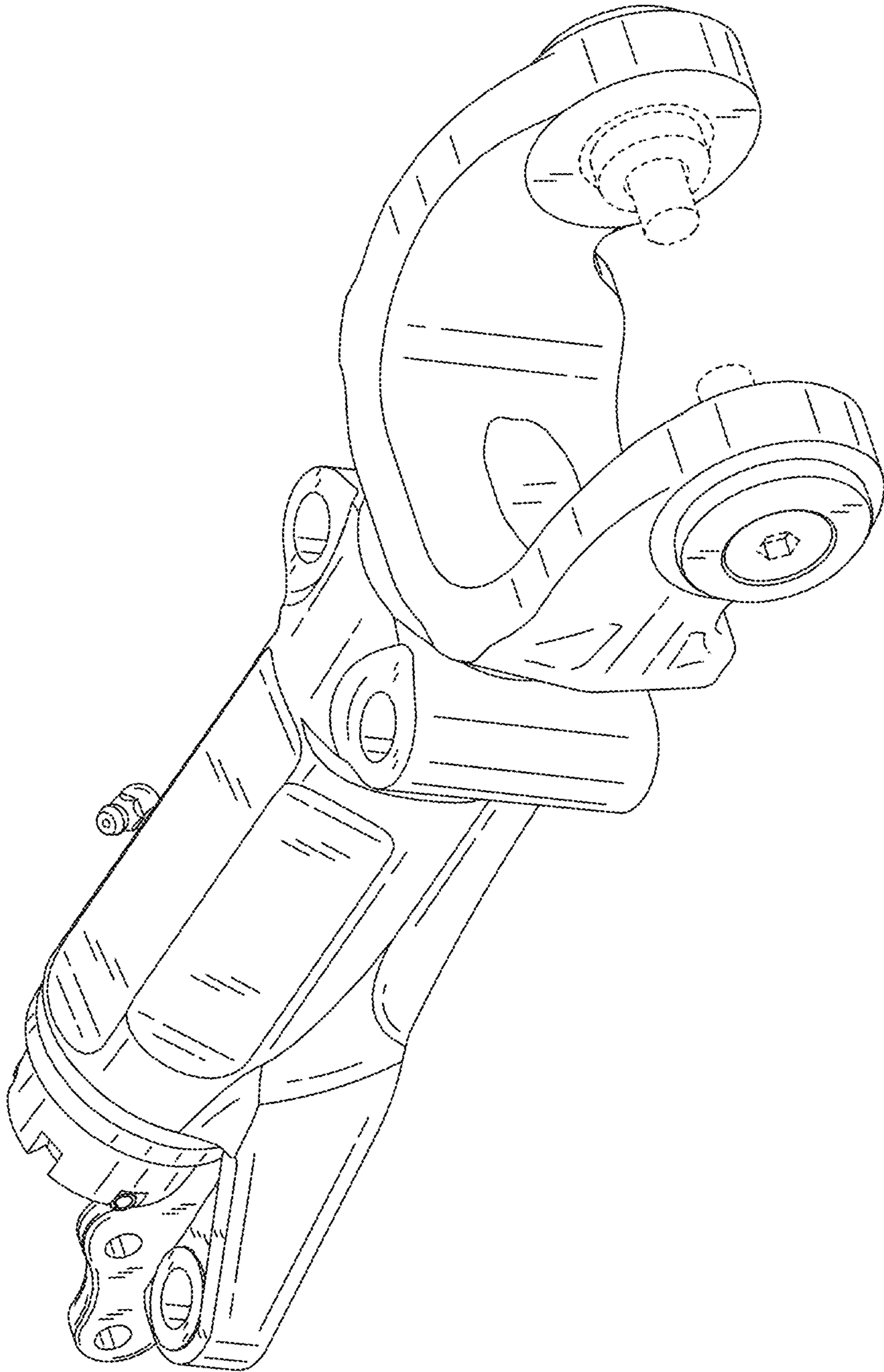

FIG. 1

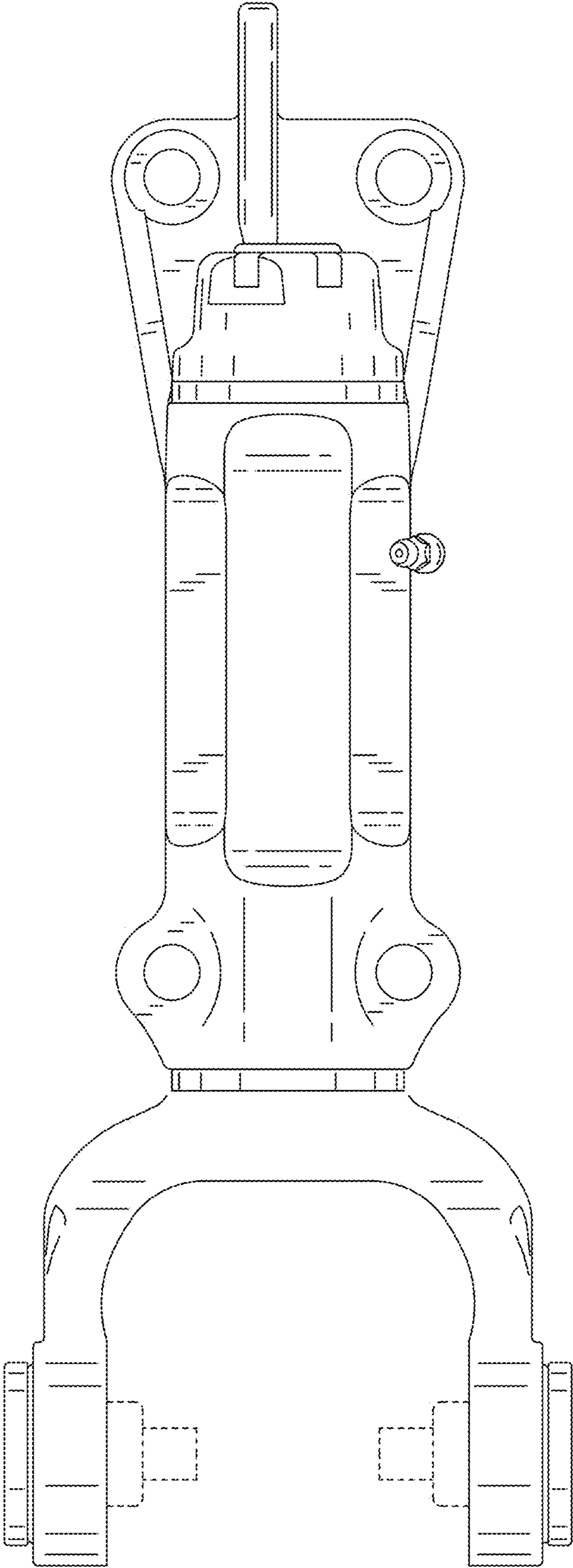

FIG. 2

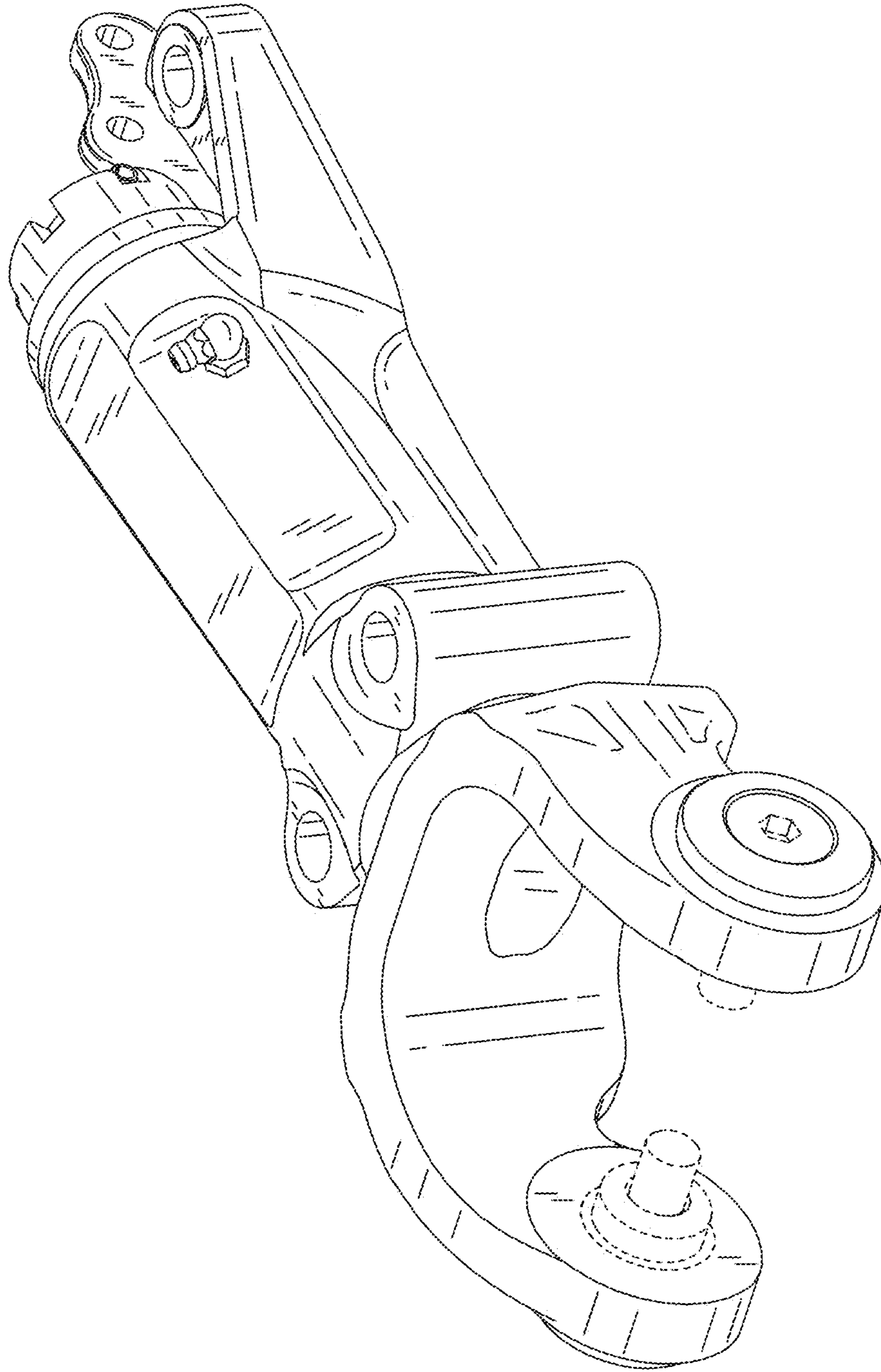

FIG. 3

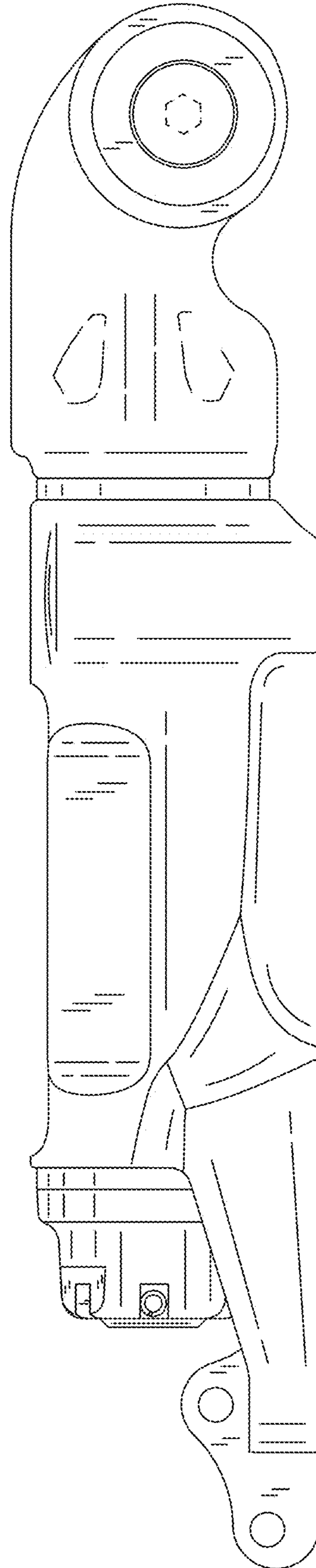

FIG. 4

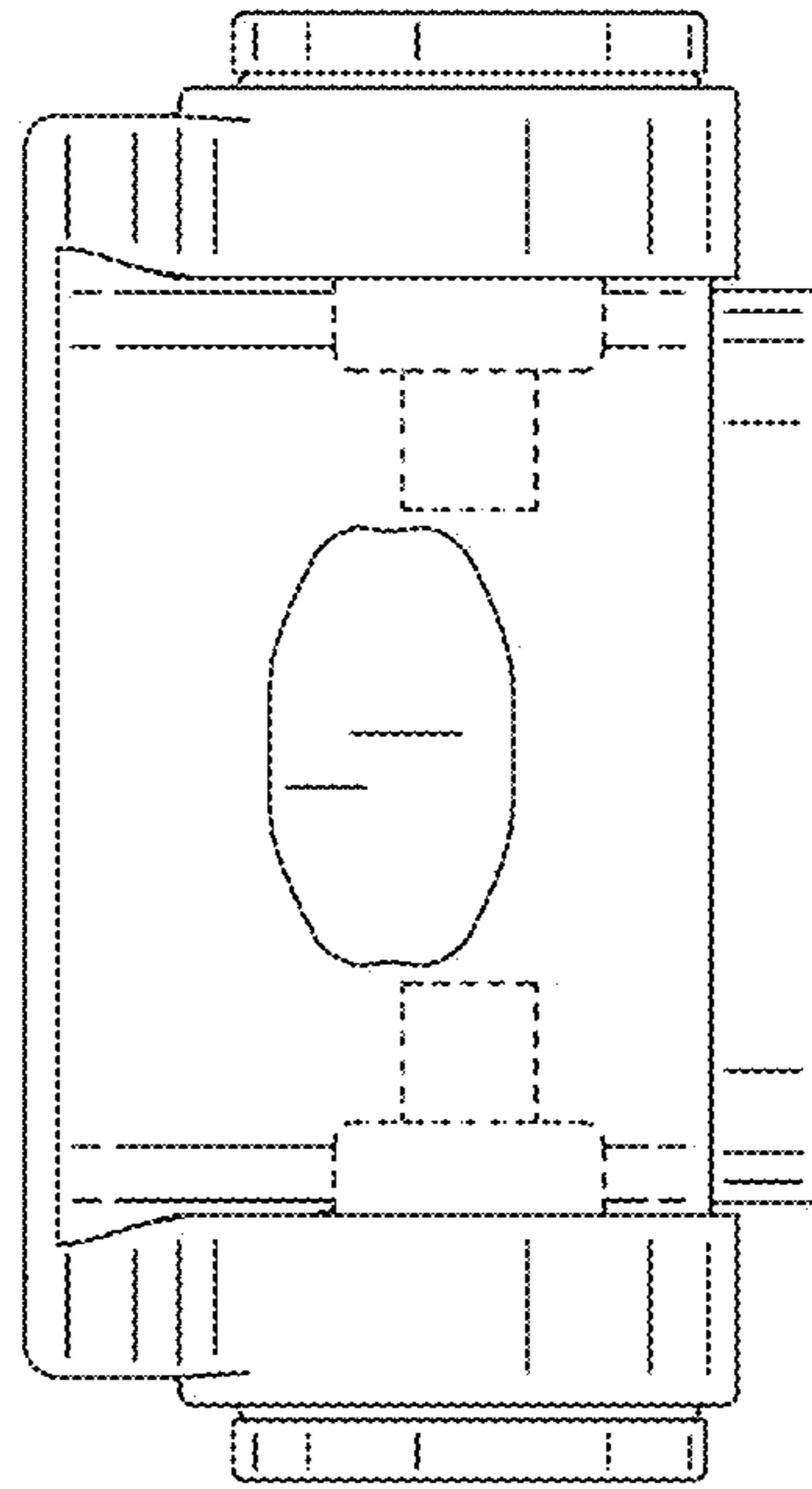

FIG. 5

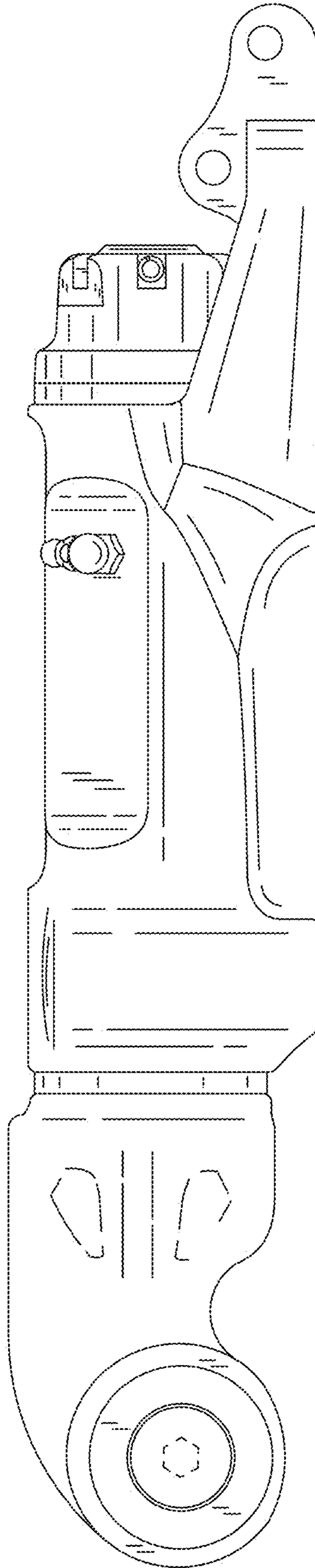

FIG. 6

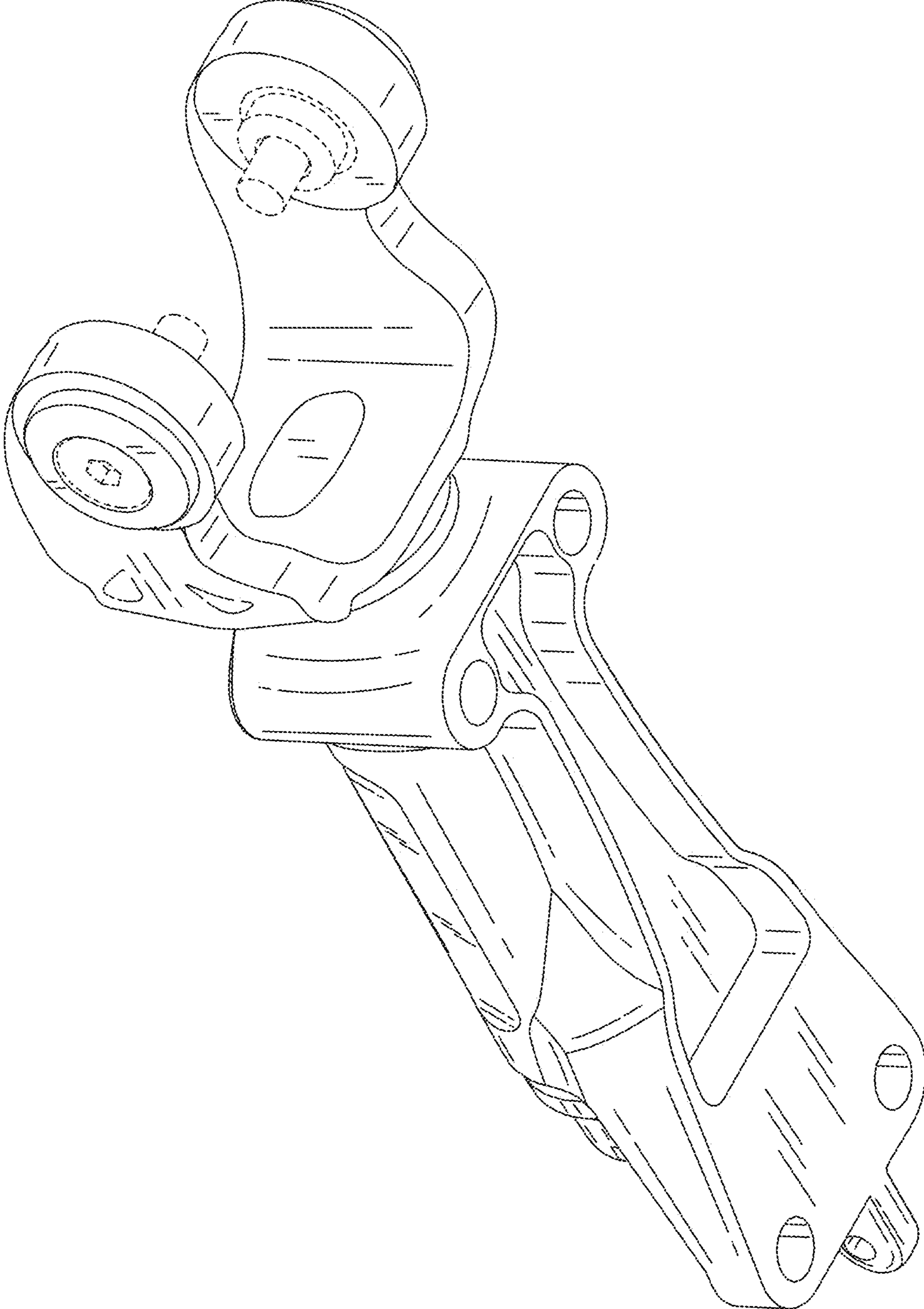

FIG. 7

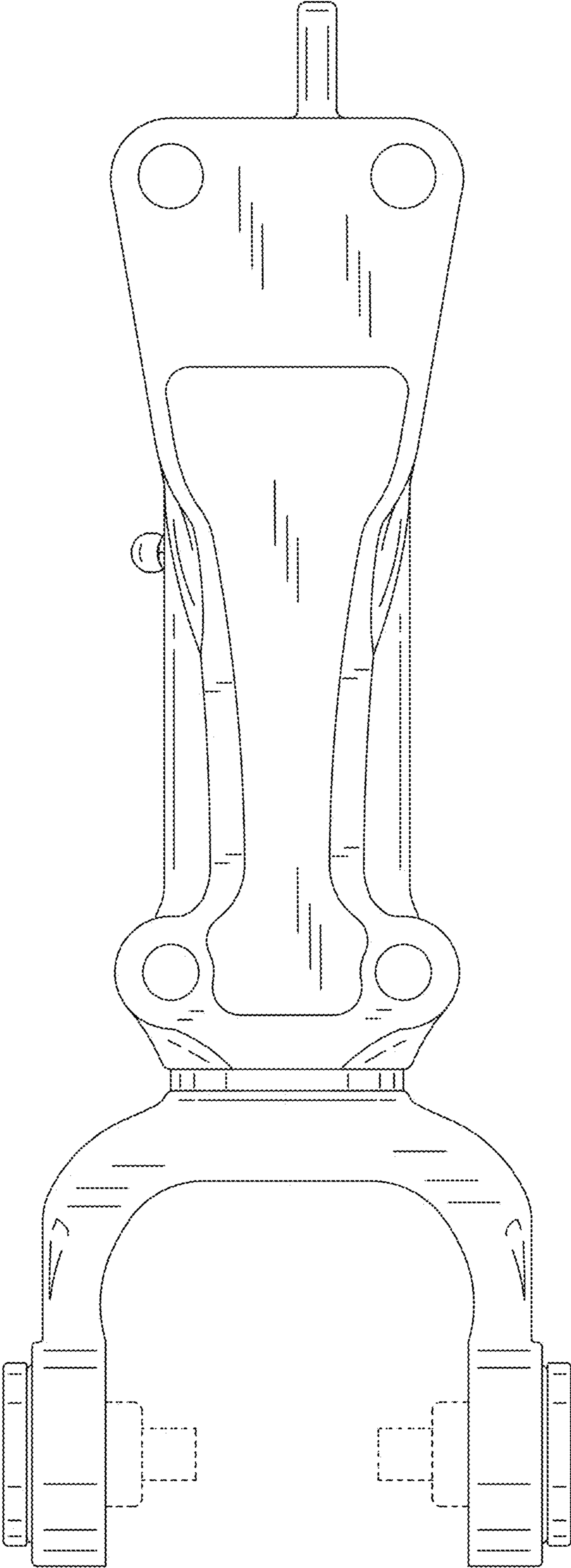

FIG. 8

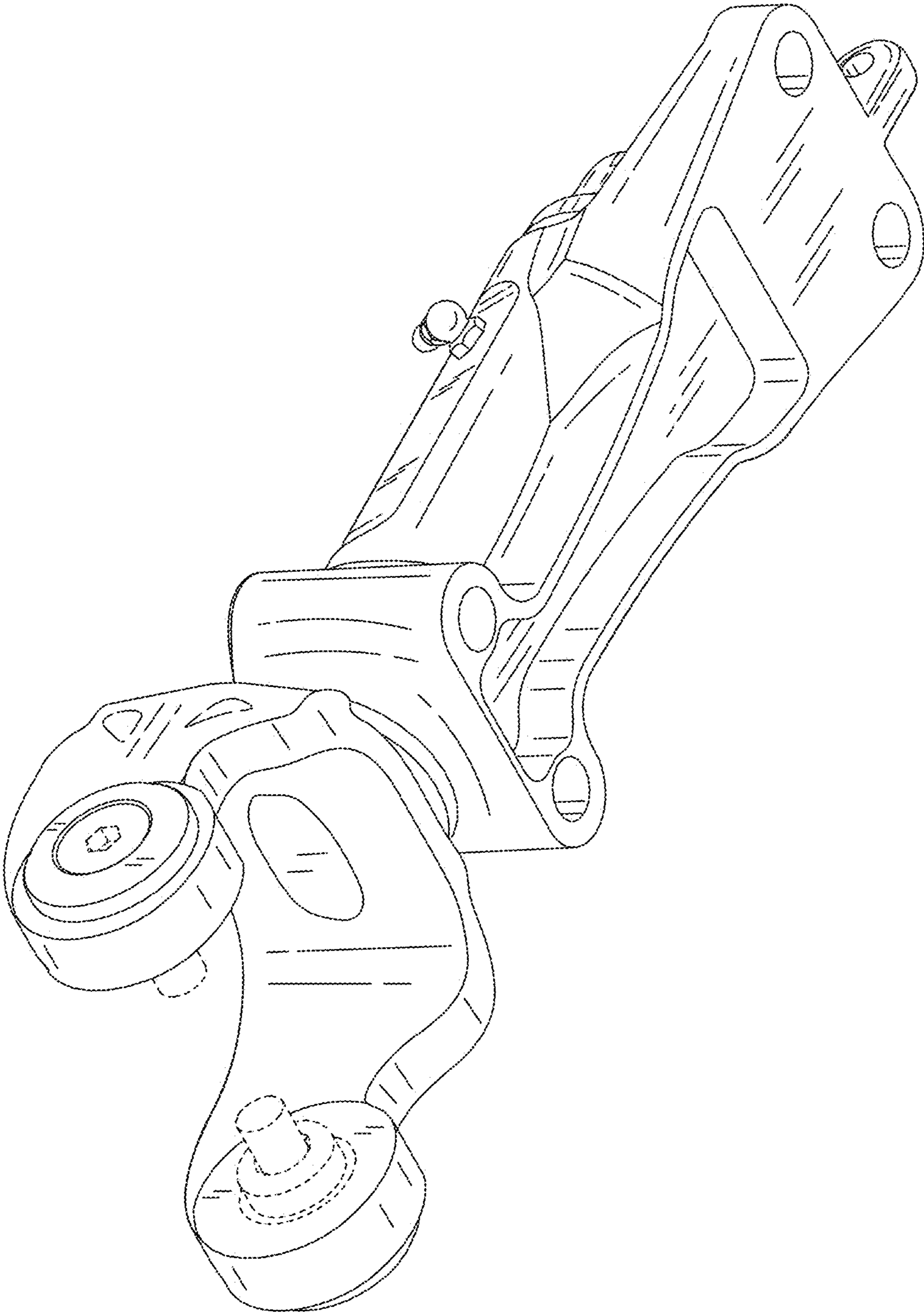

FIG. 9

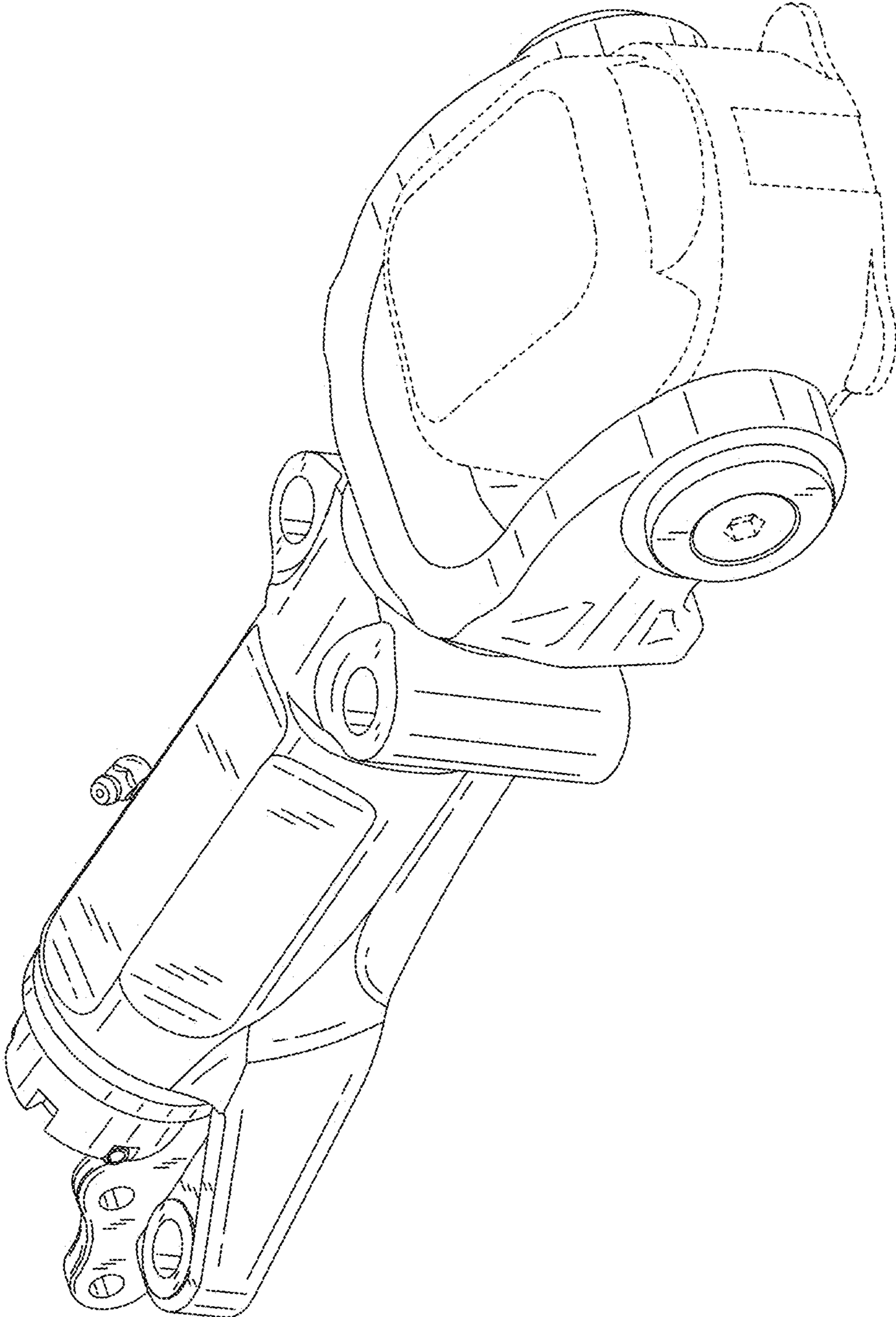

FIG. 10