



US00D935938S

(12) **United States Design Patent** (10) **Patent No.:** **US D935,938 S**
Langhals et al. (45) **Date of Patent:** **** Nov. 16, 2021**

(54) **AUTOMOBILE BODY**
(71) Applicants: **Taylor A. Langhals**, Waterford, MI (US); **Brian H. Nielander**, Royal Oak, MI (US); **Mark T. Allen**, Oxford, MI (US)
(72) Inventors: **Taylor A. Langhals**, Waterford, MI (US); **Brian H. Nielander**, Royal Oak, MI (US); **Mark T. Allen**, Oxford, MI (US)
(73) Assignee: **FCA US LLC**, Auburn Hills, MI (US)

D693,737 S * 11/2013 Hammoud D12/91
D703,583 S * 4/2014 Howell D12/91
D711,784 S * 8/2014 Galante D12/91
D723,425 S * 3/2015 Glover D12/91
D728,425 S * 5/2015 Glover D12/91
D761,695 S * 7/2016 Faghihzadeh D12/92
D801,861 S * 11/2017 Hubers D12/91
D805,956 S * 12/2017 Galante D12/91
D817,816 S * 5/2018 Hoste D12/91
D823,722 S * 7/2018 Hoste D12/91
D847,025 S * 4/2019 Zavatski D12/91
D860,863 S * 9/2019 Jonason D12/91
D865,565 S * 11/2019 Hubers D12/91
D865,566 S * 11/2019 Jonason D12/91

* cited by examiner

(**) Term: **15 Years**

Primary Examiner — Melody N Brown

(21) Appl. No.: **29/727,307**

(74) *Attorney, Agent, or Firm* — Ralph E. Smith

(22) Filed: **Mar. 10, 2020**

(57) **CLAIM**

(51) **LOC (13) Cl.** **12-08**

The ornamental design for an automobile body, as shown and described.

(52) **U.S. Cl.**
USPC **D12/91**

DESCRIPTION

(58) **Field of Classification Search**
USPC D12/86, 90–92, 88, 164; D21/424, 433, D21/434; 296/181.1–181.5, 183.1
CPC B62D 25/00; B62D 25/06; B62D 33/00; B62D 35/00

FIG. 1 is a front and right side perspective view of an automotive body showing our new design;
FIG. 2 is a front elevational view thereof;
FIG. 3 is a rear elevational view thereof;
FIG. 4 is a right side elevational view thereof;
FIG. 5 is a left side elevational view thereof;
FIG. 6 is a top plan view thereof; and,
FIG. 7 is a rear and right side perspective view thereof.
The portions of the automobile shown in broken lines are for illustrative and environmental purposes and form no part of the claimed design.

See application file for complete search history.

(56) **References Cited**

U.S. PATENT DOCUMENTS

D420,939 S * 2/2000 Faurote D12/91
D500,460 S * 1/2005 Allen D12/91
D534,097 S * 12/2006 Renkert D12/91
D551,124 S * 9/2007 Aneiros D12/92
D650,721 S * 12/2011 Galante D12/91

1 Claim, 6 Drawing Sheets

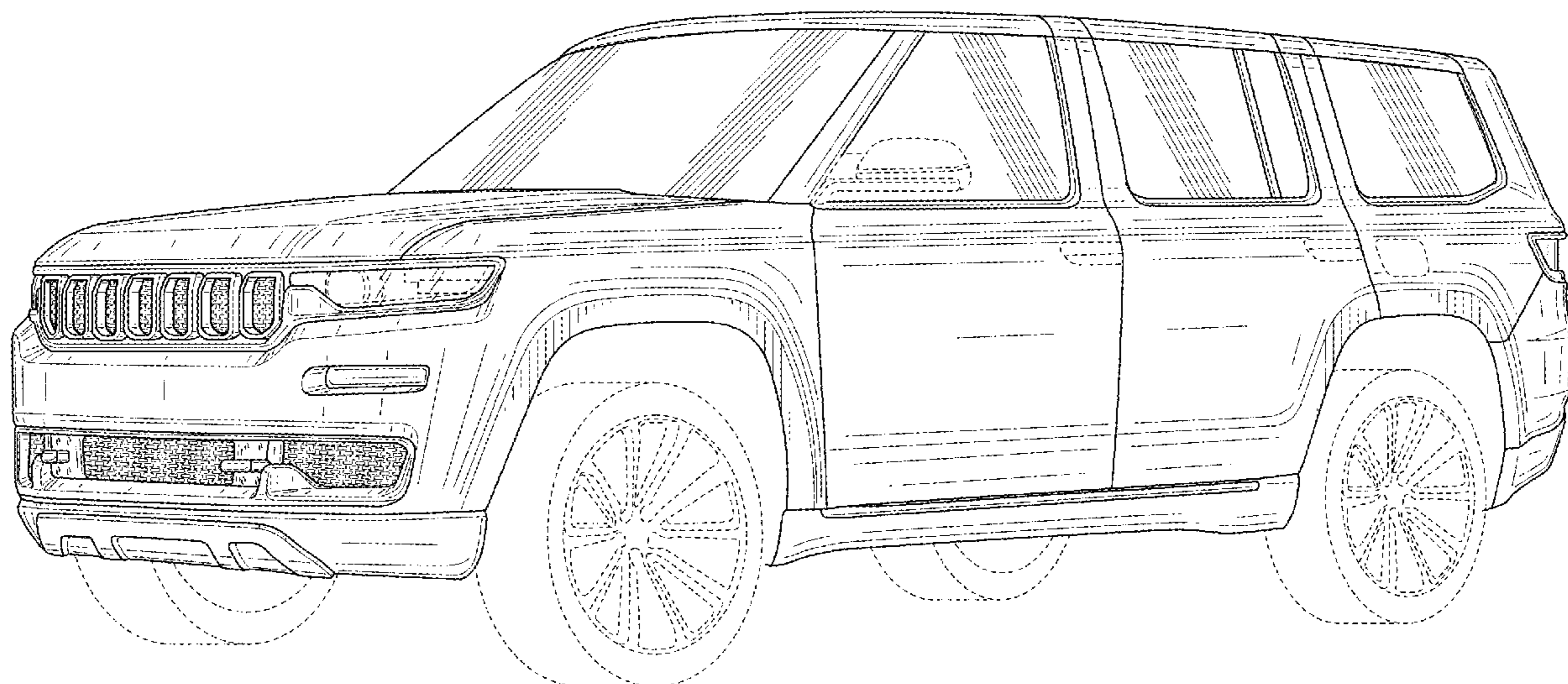

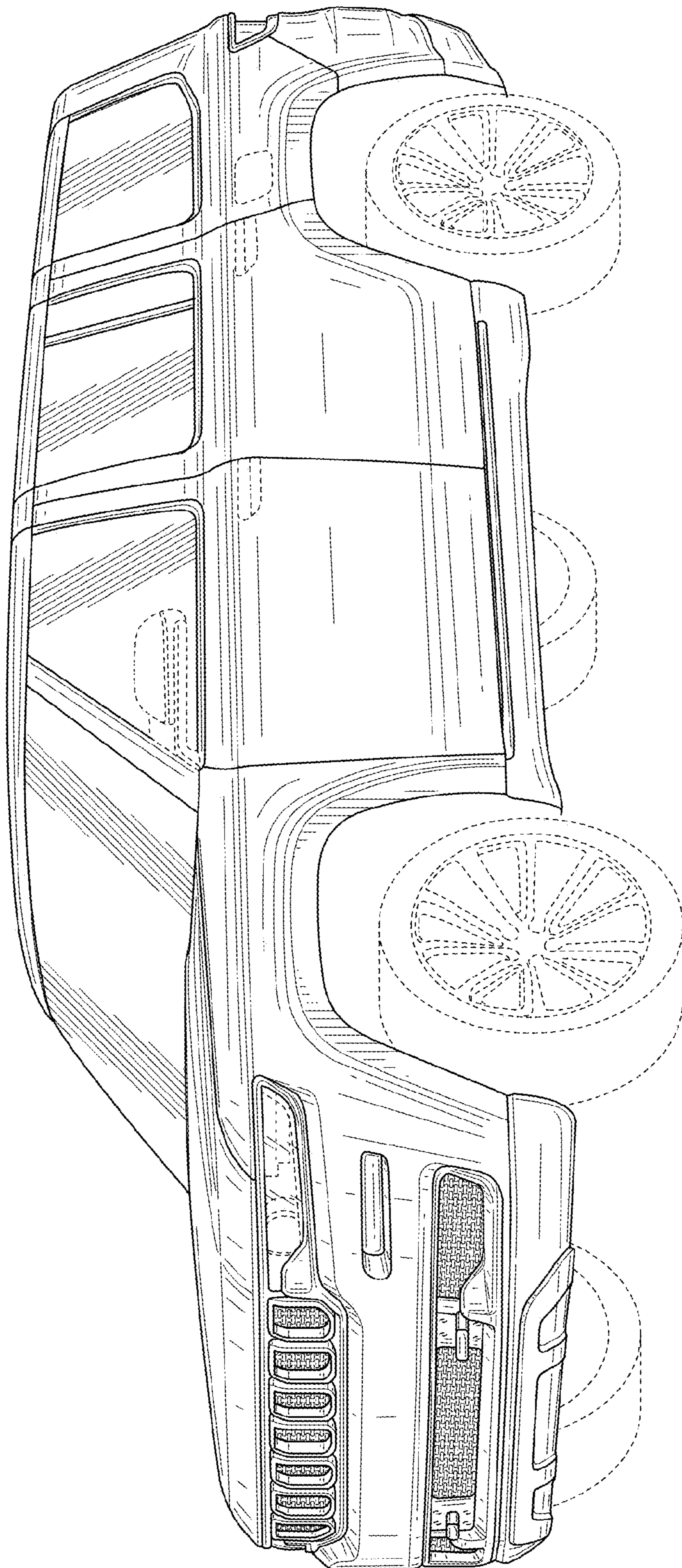

FIG. 1

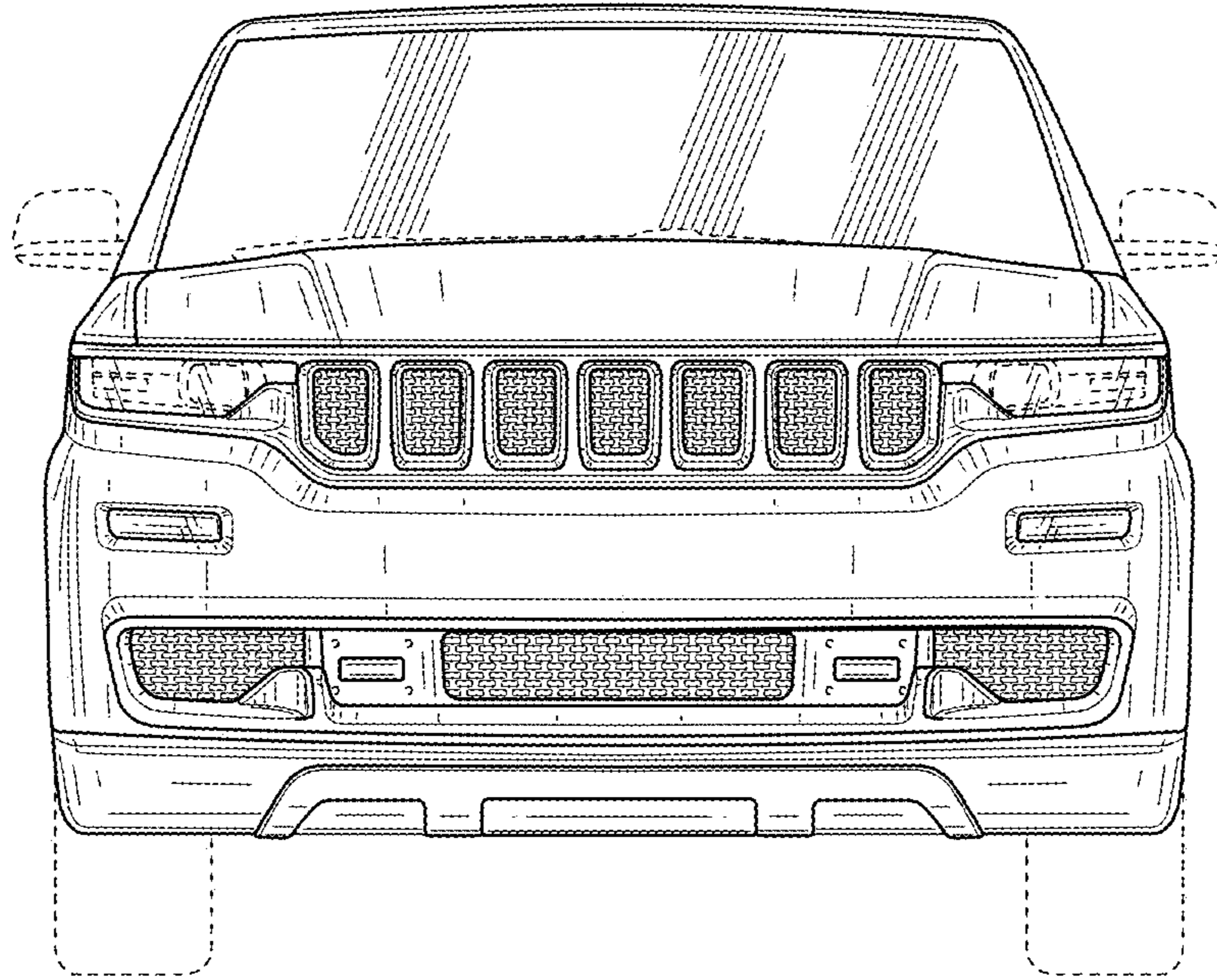

FIG. 2

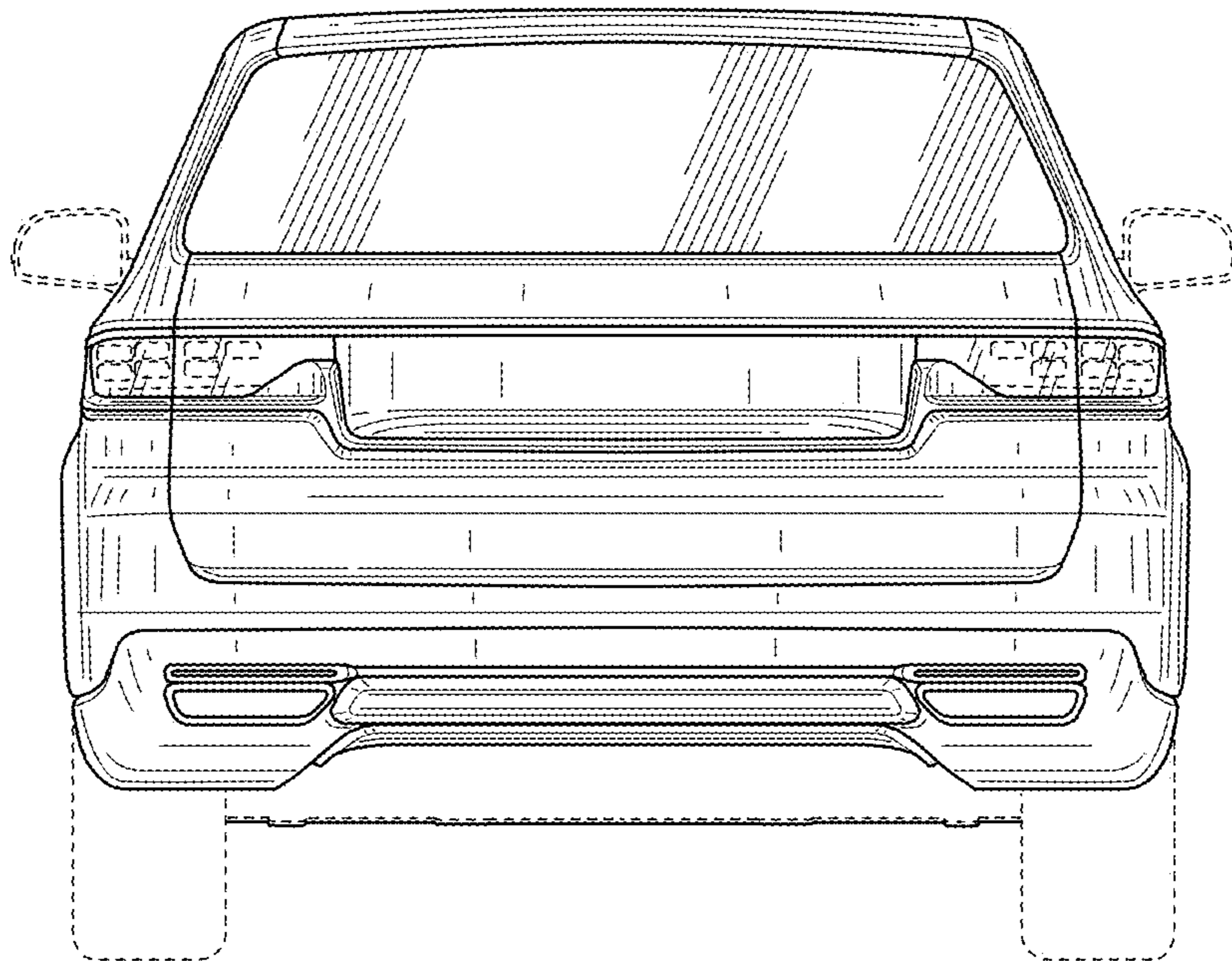

FIG. 3

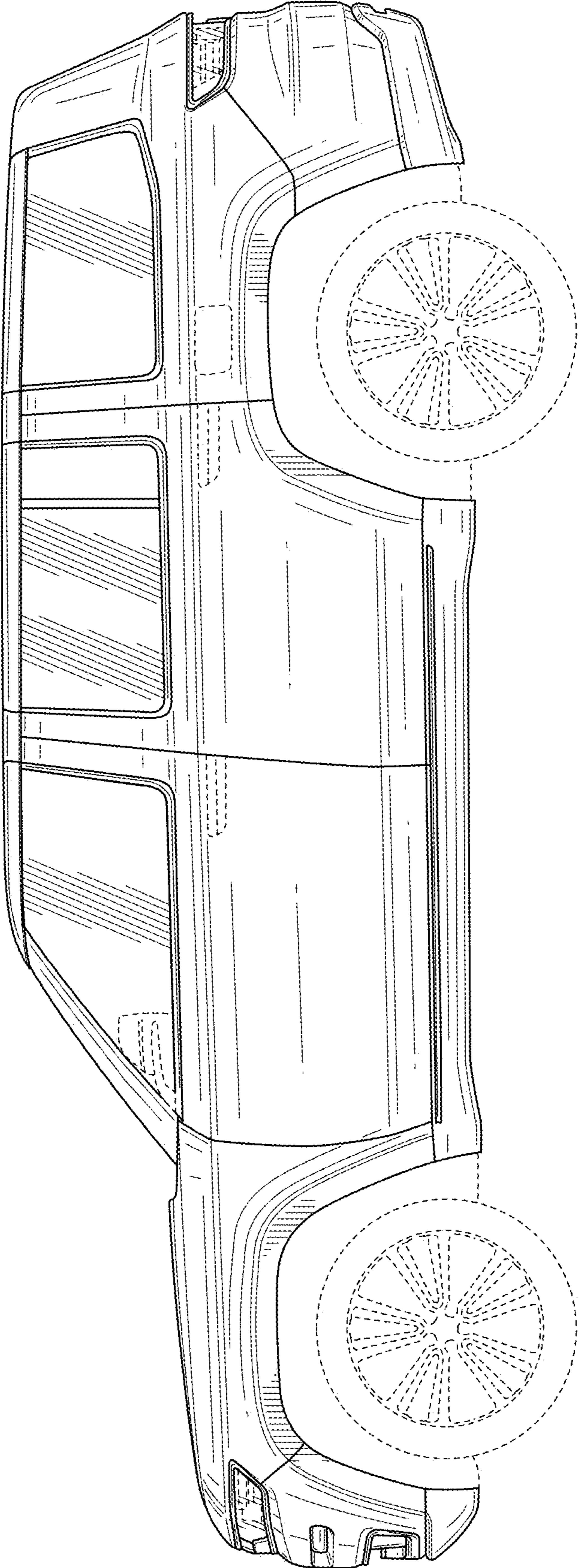

FIG. 4

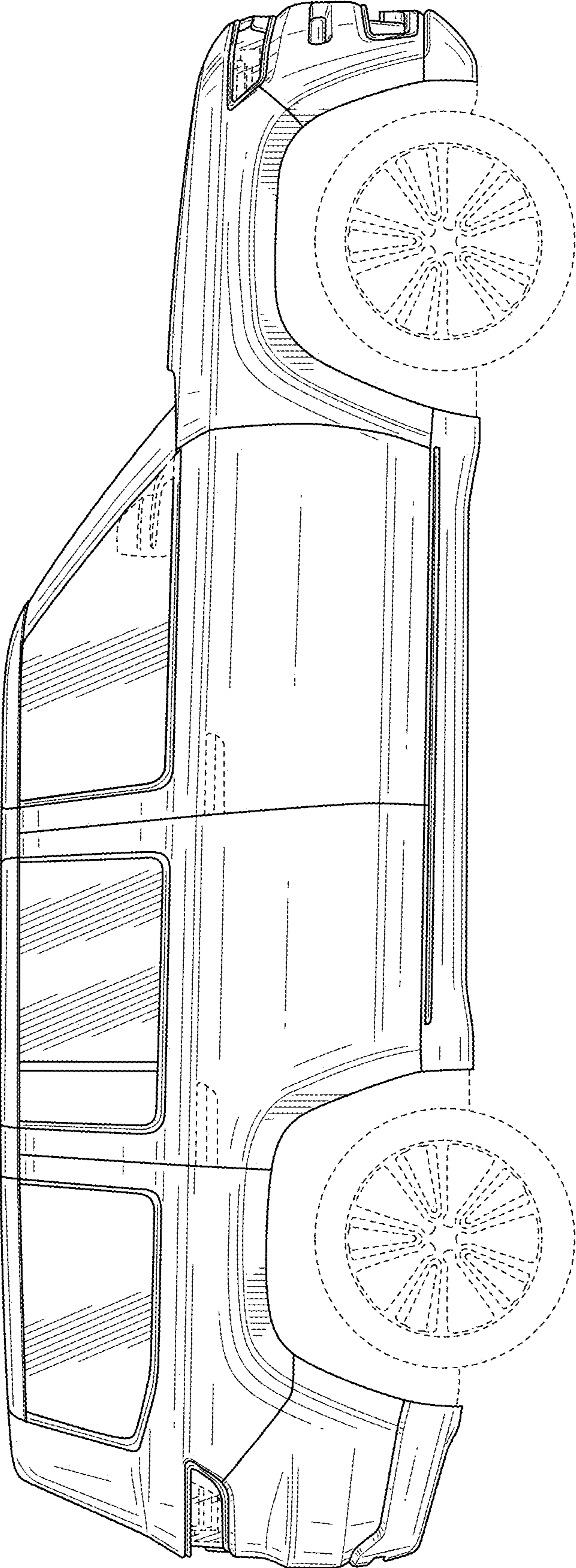

FIG. 5

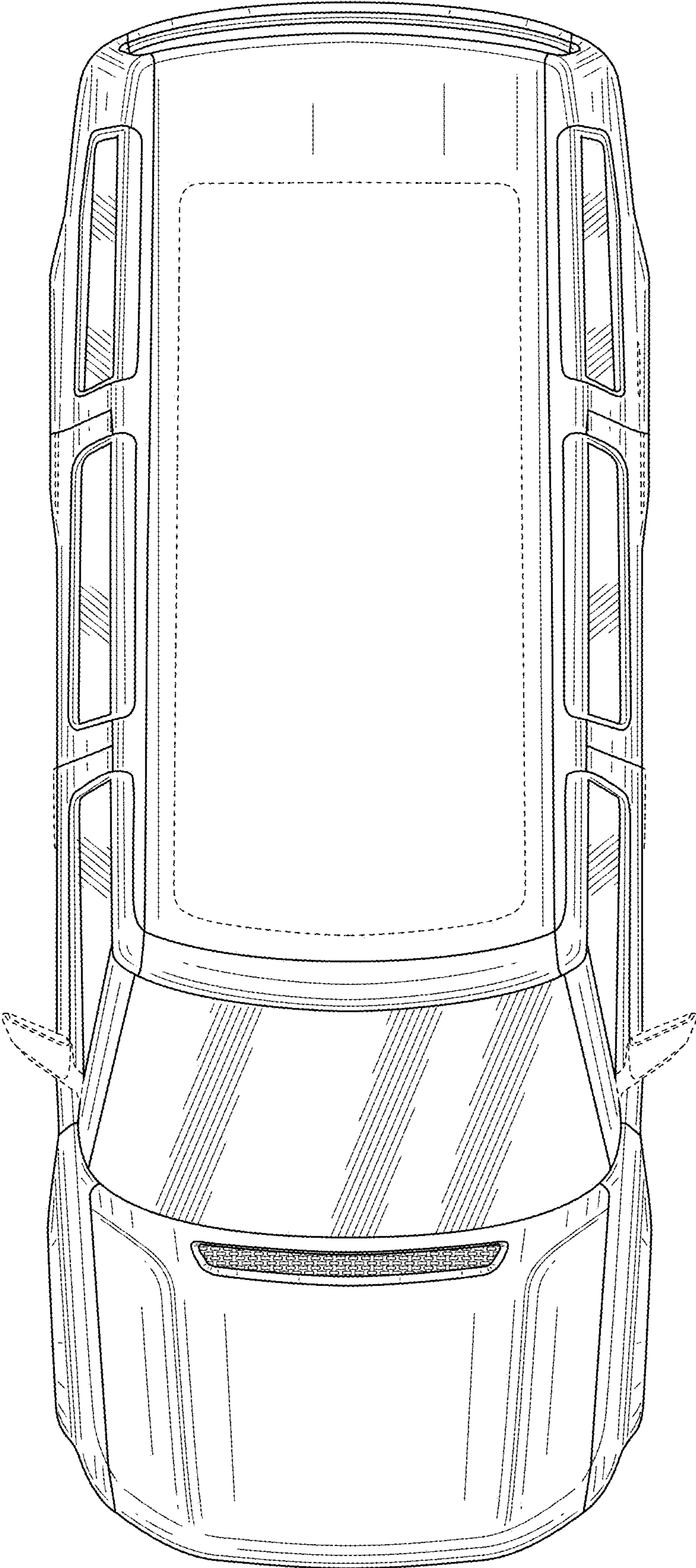

FIG. 6

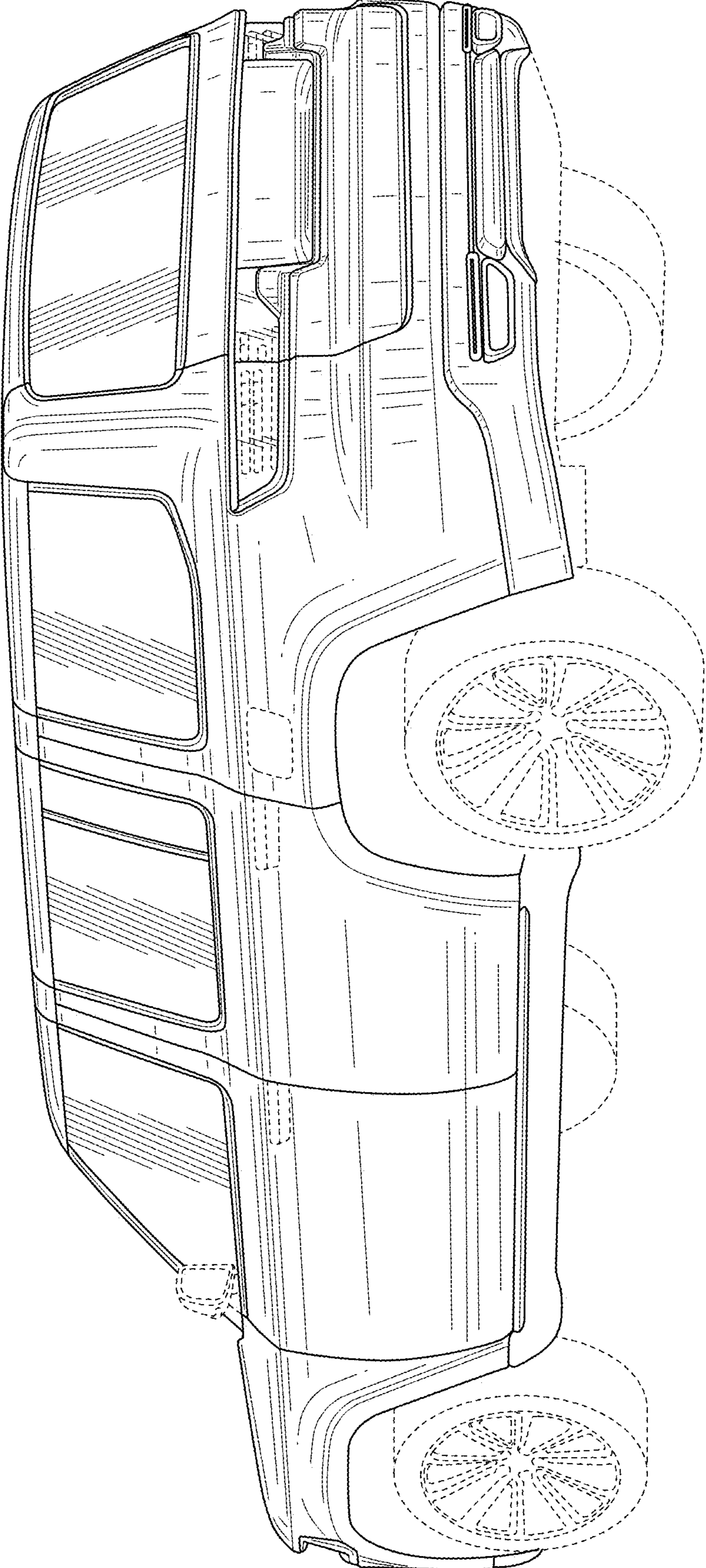

FIG. 7