



US00D935824S

(12) **United States Design Patent**
Deevers et al.

(10) **Patent No.:** **US D935,824 S**

(45) **Date of Patent:** **** Nov. 16, 2021**

- (54) **SEAT**
- (71) Applicant: **Steelcase Inc.**, Grand Rapids, MI (US)
- (72) Inventors: **Nickolaus William Charles Deevers**, Holland, MI (US); **Kurt R. Heidmann**, Grand Rapids, MI (US); **Mark Spoelhof**, Grand Rapids, MI (US)
- (73) Assignee: **Steelcase Inc.**, Grand Rapids, MI (US)

(**) Term: **15 Years**

(21) Appl. No.: **29/724,809**

(22) Filed: **Feb. 19, 2020**

(51) **LOC (13) Cl.** **06-01**

(52) **U.S. Cl.**
USPC **D6/716.1**

(58) **Field of Classification Search**
USPC D6/334, 361, 364, 365, 366, 367, 370, D6/371, 374, 379, 380, 716.1, 716.2, D6/716.4
CPC A47C 3/00; A47C 3/18; A47C 3/20; A47C 3/026; A47C 1/00; A47C 1/02; A47C 1/022; A47C 1/03; A47C 1/14; A47C 1/143; A47C 7/24; A47C 7/36; A47C 7/46; A47C 7/18; A47C 7/40; A47C 7/54
See application file for complete search history.

(56) **References Cited**

U.S. PATENT DOCUMENTS

3,041,109	A	6/1962	Eames et al.
3,606,464	A	9/1971	Arbuthnot
4,545,614	A	10/1985	Abu-Isa et al.
4,555,136	A	11/1985	Dranger
4,555,139	A	11/1985	Leib
4,826,249	A	5/1989	Bradbury
4,869,554	A	9/1989	Abu-Isa et al.
5,354,120	A	10/1994	Völkle
5,457,968	A	10/1995	McClintock et al.
5,795,026	A	8/1998	Dral

5,855,991	A	1/1999	McLarty, III
6,050,646	A	4/2000	Stenzel et al.
6,341,822	B2	1/2002	Apissomian
6,632,756	B1	10/2003	Waldrop et al.
D487,359	S	3/2004	Giugiaro
6,729,691	B2	5/2004	Koepke et al.
6,749,261	B2	6/2004	Knoblock et al.

(Continued)

FOREIGN PATENT DOCUMENTS

JP	2012085897	A	5/2012
JP	2013-132403	A	7/2013
JP	2020062346	A	4/2020

OTHER PUBLICATIONS

Sedus brochure, "se:motion, Office swivel chair for agile working", obtained from the Internet at: www.sedus.com, not dated, 20 pgs.

Primary Examiner — R. Johnson

(74) *Attorney, Agent, or Firm* — Crowell & Moring LLP

(57) **CLAIM**

The ornamental design for a seat, as shown and described.

DESCRIPTION

FIG. 1 is a front perspective view of a seat;
FIG. 2 is a rear perspective view of the seat shown in FIG. 1;
FIG. 3 is a right side view of the seat shown in FIG. 1;
FIG. 4 is a left side view of the seat shown in FIG. 1;
FIG. 5 is front view of the seat shown in FIG. 1;
FIG. 6 is a rear view of the seat shown in FIG. 1;
FIG. 7 is a top view of the seat shown in FIG. 1; and,
FIG. 8 is a bottom view of the seat shown in FIG. 1.
The ornamental design which is claimed is shown in solid lines in the drawings. The broken lines shown in FIGS. 5, 6 and 8 are for environmental purposes only and do not form any part of the claimed design.

1 Claim, 6 Drawing Sheets

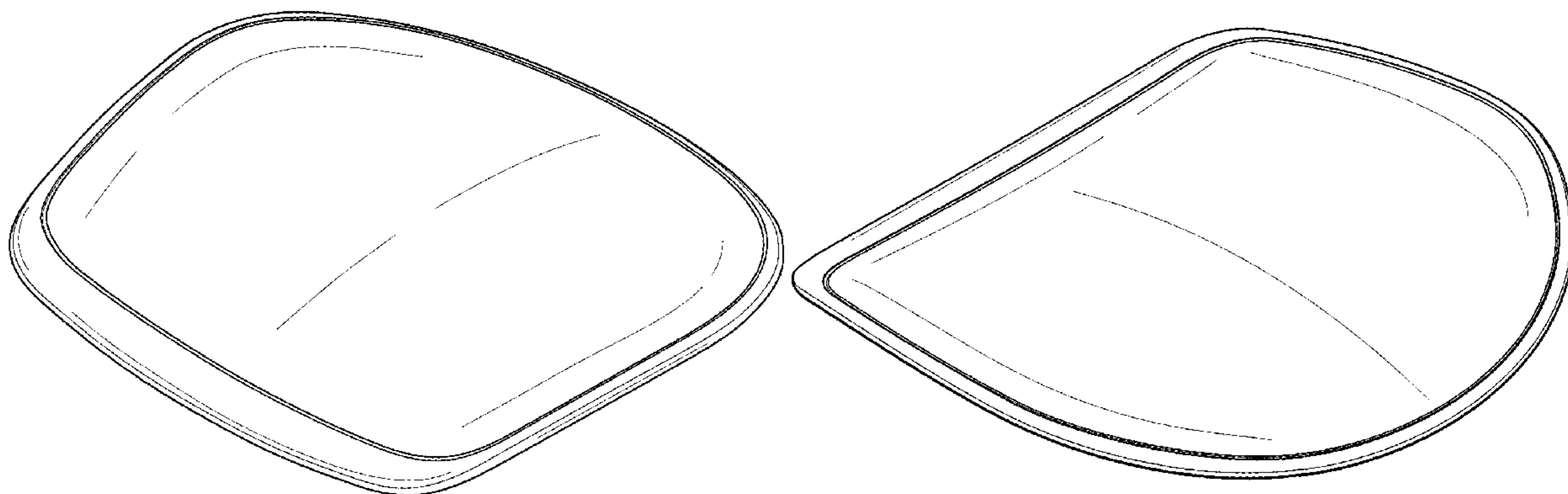

(56)

References Cited

U.S. PATENT DOCUMENTS

D496,813 S *	10/2004	Nakajima	D6/349	8,794,701 B2	8/2014	Nakayama et al.	
6,814,412 B2	11/2004	Cramb, III et al.		8,998,339 B2	4/2015	Peterson et al.	
6,951,370 B1	10/2005	Hsu		D733,445 S	7/2015	Izawa et al.	
6,983,997 B2	1/2006	Wilkerson et al.		D742,676 S	11/2015	Smith et al.	
D517,820 S *	3/2006	Citterio	D6/366	D742,677 S	11/2015	Smith et al.	
7,055,911 B2	6/2006	Simpson et al.		D742,678 S	11/2015	Smith et al.	
D527,920 S	9/2006	Giugiaro		D750,406 S	3/2016	Smith et al.	
D528,811 S	9/2006	Giugiaro		9,560,917 B2	2/2017	Roslund, Jr.	
7,159,943 B2	1/2007	Costaglia		D781,604 S	3/2017	Smith et al.	
D549,975 S *	9/2007	Fancelli	D6/366	D781,605 S	3/2017	Smith et al.	
D555,377 S	11/2007	Pensi		9,622,579 B2	4/2017	Wilkinson et al.	
D557,917 S	12/2007	Nakamura		9,648,957 B2	5/2017	Su	
D576,809 S	9/2008	Christianson et al.		D792,717 S	7/2017	Webb	
7,425,039 B2	9/2008	Lin		D802,951 S	11/2017	Ludwig et al.	
7,441,839 B2	10/2008	Pennington et al.		D802,952 S	11/2017	Ludwig et al.	
7,568,765 B2	8/2009	Bräuning		D804,209 S	12/2017	Ludwig et al.	
7,712,833 B2	5/2010	Ueda		D804,839 S	12/2017	Ludwig et al.	
7,837,272 B2	11/2010	Masunaga et al.		D804,840 S	12/2017	Ludwig et al.	
D641,983 S	7/2011	Hazzard		D804,841 S	12/2017	Ludwig et al.	
D646,088 S	10/2011	Ballendat		D804,875 S	12/2017	Ludwig et al.	
8,087,727 B2	1/2012	Parker et al.		D804,876 S	12/2017	Ludwig et al.	
8,113,582 B2	2/2012	Liu		D808,187 S	1/2018	Ludwig et al.	
D658,904 S	5/2012	Chen		D821,793 S	7/2018	Ludwig et al.	
D663,129 S	7/2012	Greutmann		D825,971 S	8/2018	Scagnellato	
8,251,448 B2	8/2012	Machael		D834,844 S	12/2018	Chan et al.	
D675,456 S	2/2013	Sexton		10,173,567 B2	1/2019	Madrigal et al.	
D683,150 S	5/2013	Smith et al.		D852,525 S	7/2019	Peterson	
D683,151 S	5/2013	Smith et al.		D852,526 S *	7/2019	Peterson	D6/366
D688,497 S	8/2013	Smith et al.		D863,802 S *	10/2019	Wang	D6/366
D688,498 S	8/2013	Smith et al.		D869,872 S *	12/2019	Deevers	D6/366
D688,499 S	8/2013	Smith et al.		D870,479 S	12/2019	Deevers et al.	
D688,500 S	8/2013	Smith et al.		D873,043 S *	1/2020	Su	D6/366
D688,501 S	8/2013	Smith et al.		D873,576 S	1/2020	Engelhardt	
D688,503 S	8/2013	Smith et al.		D874,202 S	2/2020	Schmitz et al.	
D688,504 S	8/2013	Smith et al.		D878,789 S	3/2020	Wang	
D688,505 S	8/2013	Smith et al.		D879,523 S	3/2020	Lampela et al.	
D689,312 S	9/2013	Smith et al.		D880,885 S	4/2020	Li	
D689,313 S	9/2013	Smith et al.		D881,621 S	4/2020	Jin et al.	
D689,314 S	9/2013	Smith et al.		10,617,226 B1	4/2020	Liao	
D689,317 S	9/2013	Smith et al.		D883,690 S	5/2020	Dassen	
D689,318 S	9/2013	Smith et al.		D883,691 S	5/2020	Dassen	
D690,146 S	9/2013	Smith et al.		D887,157 S *	6/2020	Holbrook	D6/366
D690,547 S	10/2013	Smith et al.		D899,836 S	10/2020	Chu	
D694,536 S	12/2013	Smith et al.		D902,614 S	11/2020	Peng	
D694,537 S	12/2013	Smith et al.		D903,353 S	12/2020	Meda	
D694,538 S	12/2013	Smith et al.		D906,711 S	1/2021	Li	
D694,539 S	12/2013	Smith et al.		D907,935 S *	1/2021	Deevers	D6/366
D694,540 S	12/2013	Smith et al.		D908,381 S	1/2021	Breen	
D695,034 S	12/2013	Smith et al.		D912,419 S	3/2021	Chen	
D697,726 S	1/2014	Smith et al.		2003/0189367 A1	10/2003	Erker	
D697,728 S	1/2014	Smith et al.		2007/0057560 A1 *	3/2007	Fookes	A47C 1/03 297/411.35
D697,729 S	1/2014	Smith et al.		2007/0108821 A1	5/2007	Ueda	
D697,730 S	1/2014	Smith et al.		2008/0100121 A1 *	5/2008	Serber	A47C 1/023 297/452.1
D698,164 S	1/2014	Smith et al.		2009/0018833 A1	1/2009	Kozat et al.	
D698,165 S	1/2014	Smith et al.		2009/0261644 A1	10/2009	Piretti	
D698,166 S	1/2014	Smith et al.		2011/0233979 A1	9/2011	An	
D699,957 S	2/2014	Smith et al.		2013/0341980 A1	12/2013	Halliday et al.	
D699,958 S	2/2014	Smith et al.		2014/0077429 A1	3/2014	Batthey	
D699,959 S	2/2014	Smith et al.		2014/0077541 A1	3/2014	Krupiczewicz	
D699,994 S	2/2014	Smith et al.		2014/0077548 A1	3/2014	Peterson	
D701,053 S	3/2014	Smith et al.		2016/0220025 A1 *	8/2016	Piretti	A47C 1/03294
8,690,249 B2	4/2014	Kang et al.		2018/0310721 A1	11/2018	Schmitz et al.	
D707,976 S	7/2014	Smith		2020/0085194 A1	3/2020	Maier et al.	
D708,882 S	7/2014	Hsuan-Chin		2020/0305610 A1 *	10/2020	Bock	A47C 3/026

* cited by examiner

FIG. 1

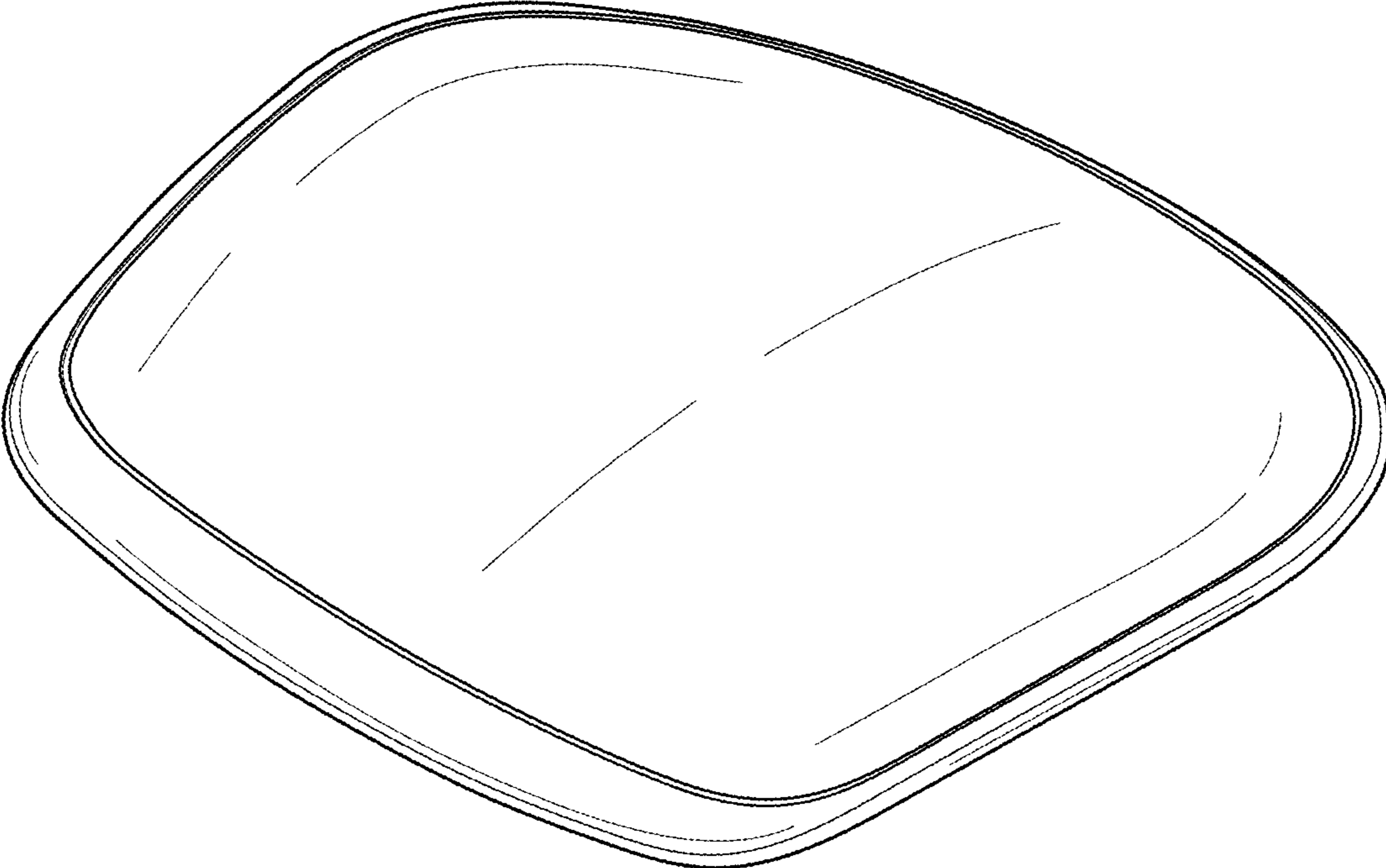

FIG. 2

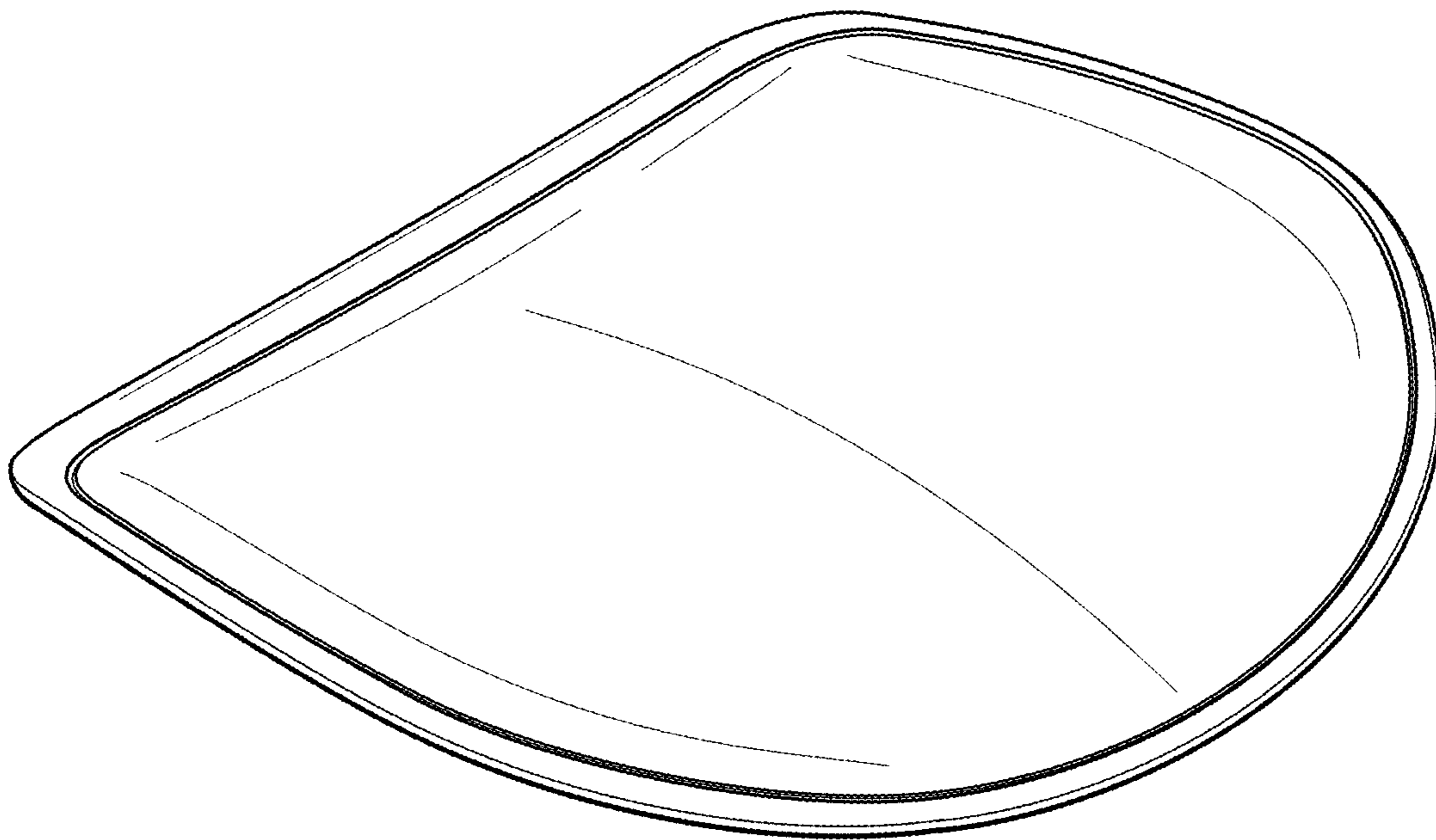

FIG. 3

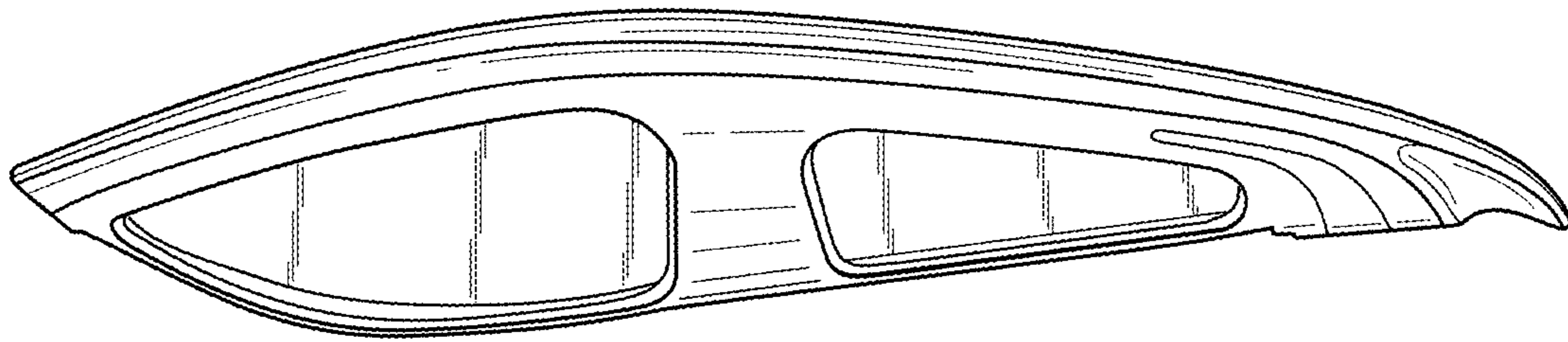

FIG. 4

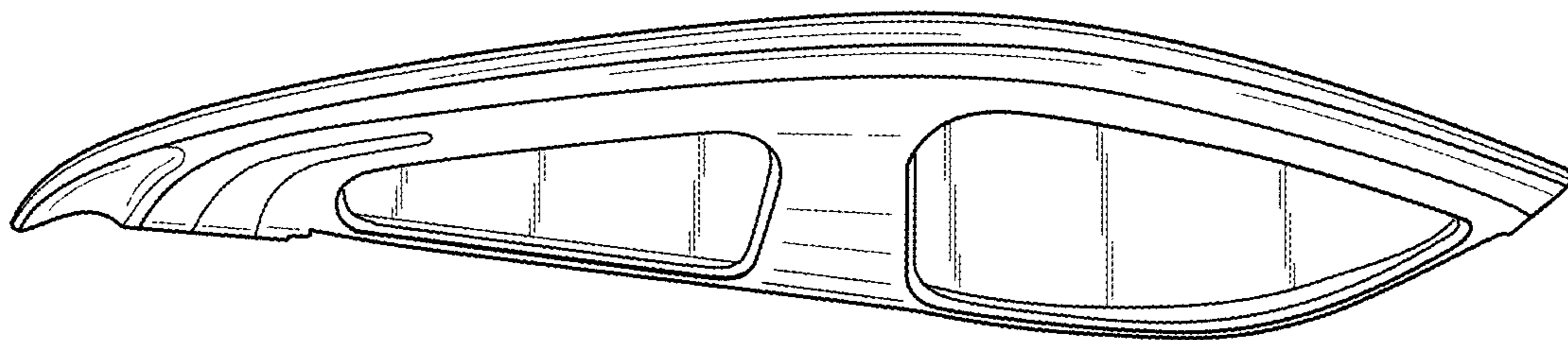

FIG. 5

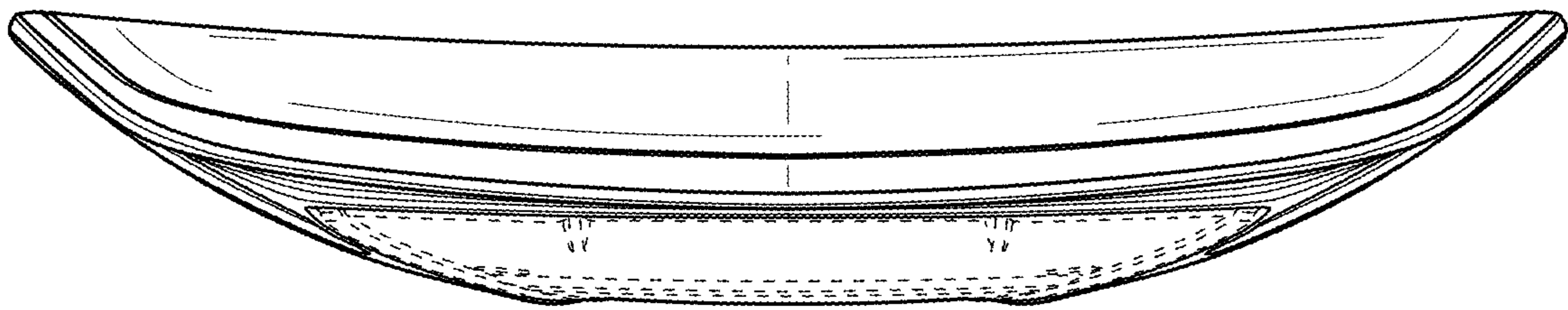

FIG. 6

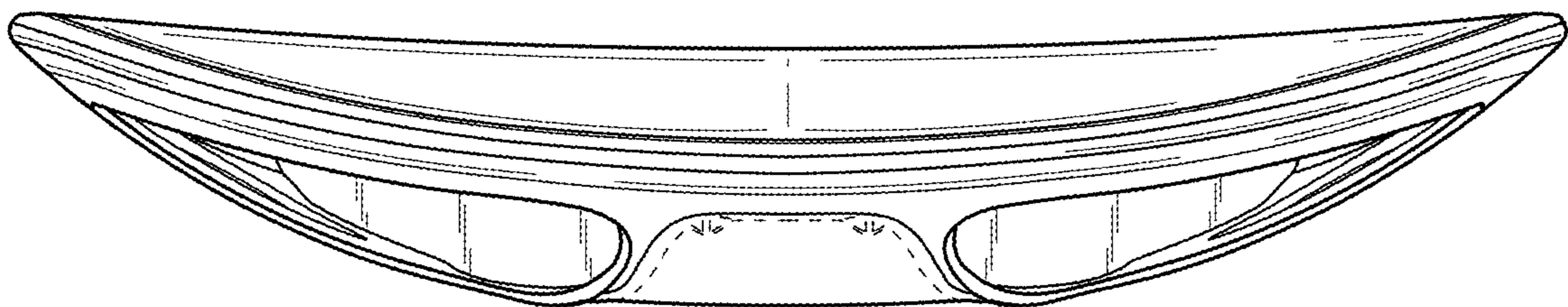

FIG. 7

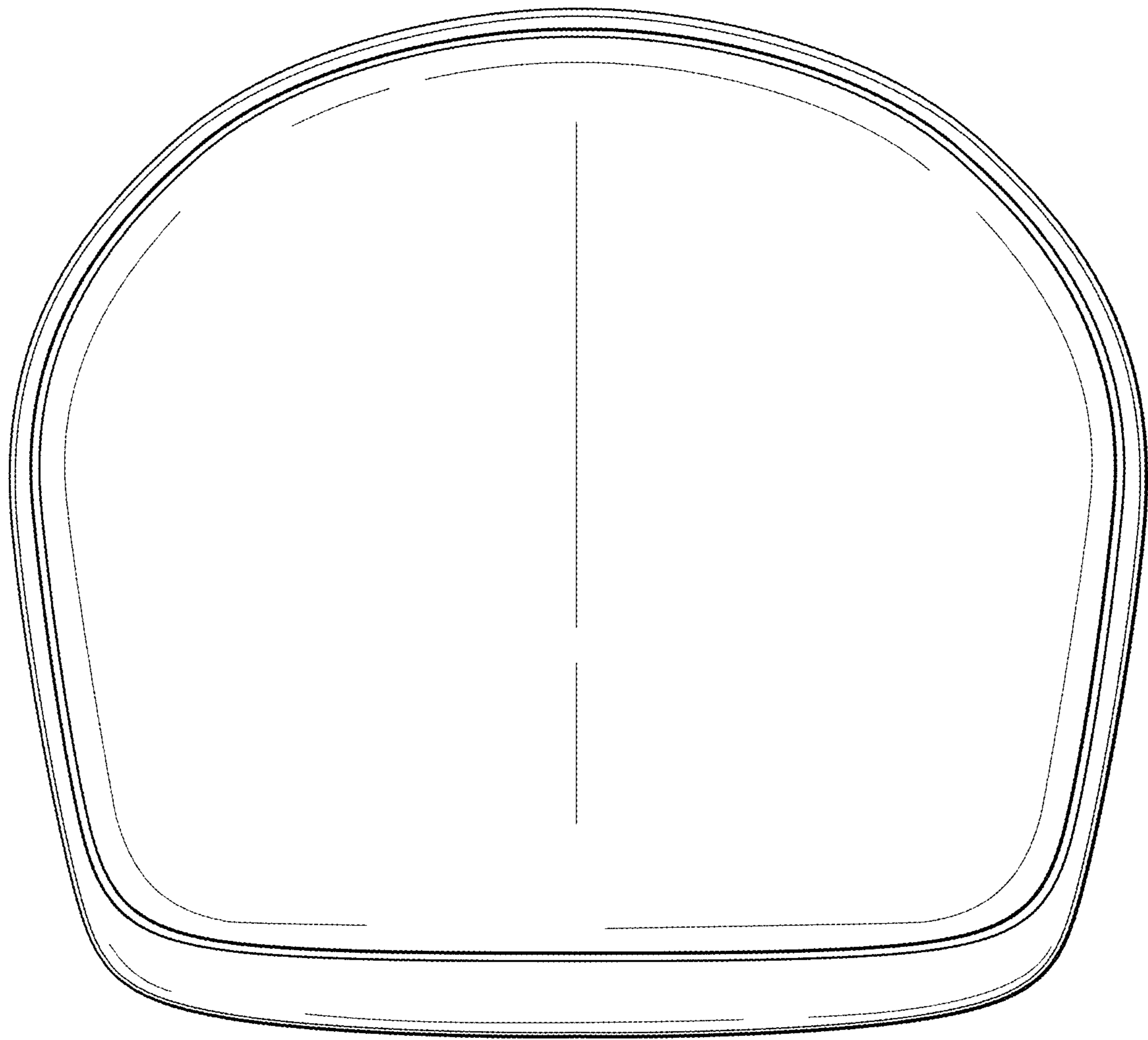

FIG. 8

