



US00D935744S

(12) **United States Design Patent** (10) **Patent No.:** **US D935,744 S**
Johnson (45) **Date of Patent:** **** Nov. 16, 2021**

(54) **UPPER GARMENT**

D885,013 S * 5/2020 Tran D2/829
D901,841 S * 11/2020 Johnson D2/847
D915,740 S * 4/2021 Johnson D2/847

(71) Applicant: **Brooke Johnson**, Bellevue, IA (US)

(72) Inventor: **Brooke Johnson**, Bellevue, IA (US)

(**) Term: **15 Years**

(21) Appl. No.: **29/652,412**

(22) Filed: **Aug. 10, 2020**

FOREIGN PATENT DOCUMENTS

DE 202010016485 * 4/2011

OTHER PUBLICATIONS

Women's Solid Plus Size Lace Open Front Bolero Shrug by Winwinus, posted to amazon.com. Available date: Sep. 10, 2018 [site visited Feb. 12, 2021] Available: <www.amazon.com/Winwinus-Womens-Solid-Patchwork-Bolero/dp/B07H787S6F/ref=sM_294?dchild=1&%20keywords=ruffle%2Bbolero&qid=1584973930&sr=8-294&th=1> (Year: 2018).*
Pirate Steampunk Jacket Bolero by blackmirrordesign, posted to etsy.com. Available date: Jan. 6, 2018 [site visited Feb. 12, 2021] Available: <https://www.pinterest.com/pin/475622410623209326/> (Year: 2018).*

(Continued)

Primary Examiner — Kevin K Rudzinski
(74) *Attorney, Agent, or Firm* — Dunlap Bennett & Ludwig, PLLC

Related U.S. Application Data

(62) Division of application No. 29/633,580, filed on Jan. 15, 2018, now Pat. No. Des. 901,841.

(51) **LOC (13) Cl.** **02-02**

(52) **U.S. Cl.**
USPC **D2/847**

(58) **Field of Classification Search**
USPC D2/847, 751, 828, 762, 842, 743, 830
CPC A41B 1/00
See application file for complete search history.

(56) **References Cited**

U.S. PATENT DOCUMENTS

D100,451 S * 7/1936 Roseman D2/751
D103,278 S * 2/1937 Freedman D2/842
D106,282 S * 10/1937 Burke D2/762
D109,027 S * 3/1938 Scheinwald D2/751
D113,801 S * 3/1939 Ciccone D2/765
D157,556 S * 3/1950 Ackerman D2/735
D171,658 S * 3/1954 Morris D2/751
D315,051 S * 3/1991 Schanink D2/743
D352,594 S * 11/1994 Evans D2/735
D618,885 S * 7/2010 Ballsieper D2/828
D618,886 S * 7/2010 Ballsieper D2/828
D764,146 S * 8/2016 Lopez D2/828
D777,057 S * 1/2017 Singer D11/160

(57) **CLAIM**

The ornamental design for an upper garment, as shown and described.

DESCRIPTION

FIG. 1 is a front perspective view of an upper garment;
FIG. 2 is a front elevation view of FIG. 1;
FIG. 3 is a rear elevation view of FIG. 1;
FIG. 4 is a left side elevation view of FIG. 1, the right side elevation view being a mirror image thereof;
FIG. 5 is a top elevation view of FIG. 1; and,
FIG. 6 is a bottom elevation view of FIG. 1.

1 Claim, 3 Drawing Sheets

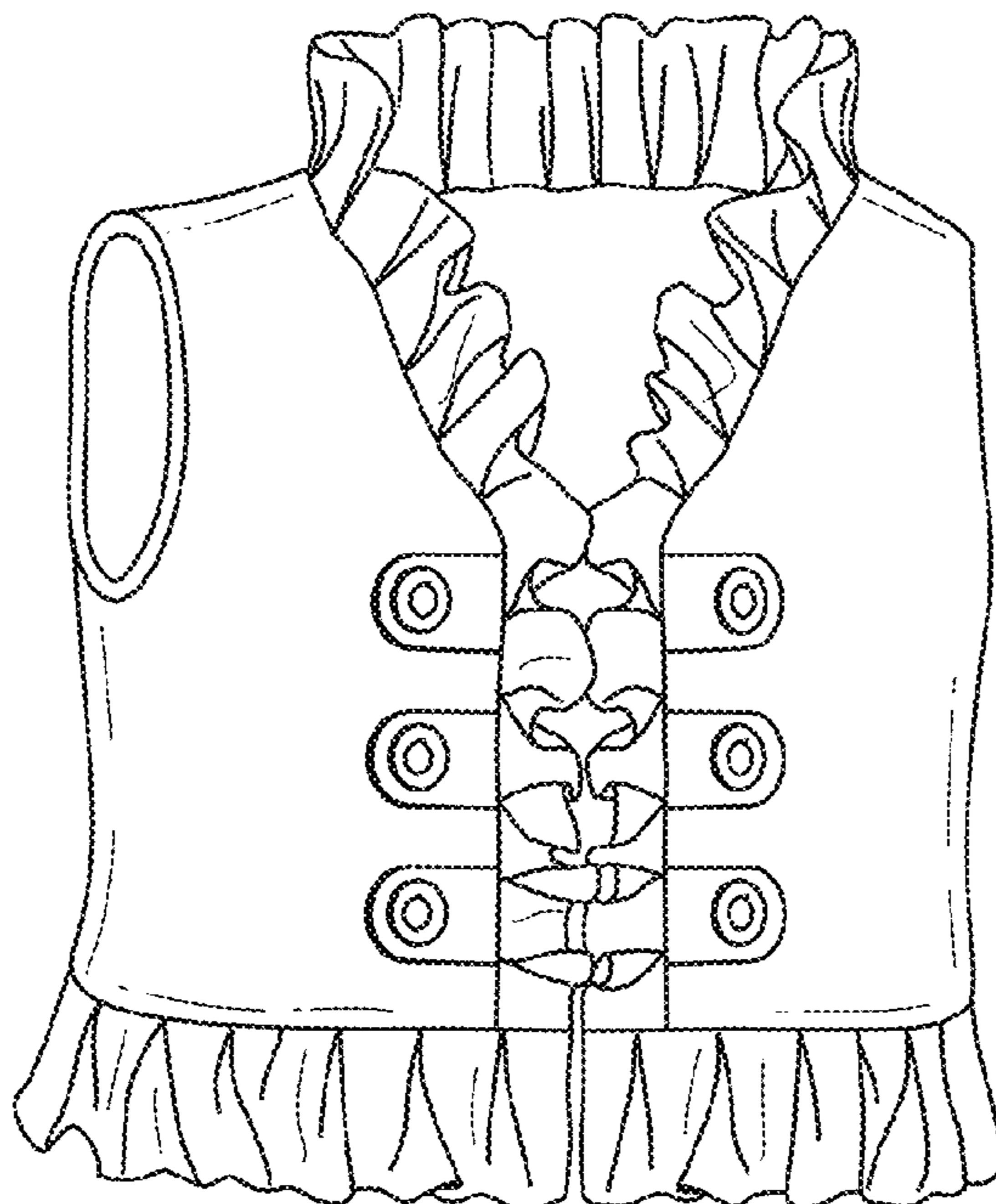

(56)

References Cited

OTHER PUBLICATIONS

New Pattern Ruffle Bolero Now Available in the Shop by Heidi & Finn, posted to heidiandfinn.blogspot.com. Available date: Nov. 8, 2010 [site visited Feb. 12, 2021] Available: <<http://heidiandfinn.blogspot.com/2010/11/new-pattern-ruffle-bolero-now-available.html>> (Year: 2010).*

Frill Lace & Ruffle Bolero Cardigan posted to lolibrary.org. Available date: Mar. 8, 2012 [site visited Feb. 12, 2021] Available: <<https://lolibrary.org/items/h-naoto-frill-lace-ruffle-bolero-cardigan-2012>> (Year: 2012).*

Ruffle Frill Pattern Black Leather Jacket Custom Made Sheep Skin posted by ind-sale to etsy.com. Available date: Oct. 24, 2017 [site visited Feb. 12, 2021] Available: <<https://www.ebay.com/itm/Ruffle-Frill-Pattern-Black-Leather-Jacket-Custom-Made-Sheep-Skin-ALL-Size-Zipper-/191889192083>> (Year: 2017).*

Women's Grey and Black Ruffled Shoulder Holster posted by TreadleWorksDesigns to etsy.com. Available date: Jun. 21, 2014 [site visited Feb. 12, 2021] Available: <https://www.etsy.com/listing/222994601/womens-grey-and-black-ruffled-shoulder?utm_source=Pinterest&utm_medium=PageTools&utm_campaign=Share> (Year: 2014).*

Women's Leather Waistcoat Steampunk Top Bolero Ruffled by Eimee, posted to amazon.com. Available date: Nov. 15, 2017 [site visited Jul. 30, 2021] Available: <<https://www.amazon.com/Eimee-Leather-Waistcoat-Steampunk-Ruffled/dp/B077NPQ4K4?th=1>> (Year: 2017).*

* cited by examiner

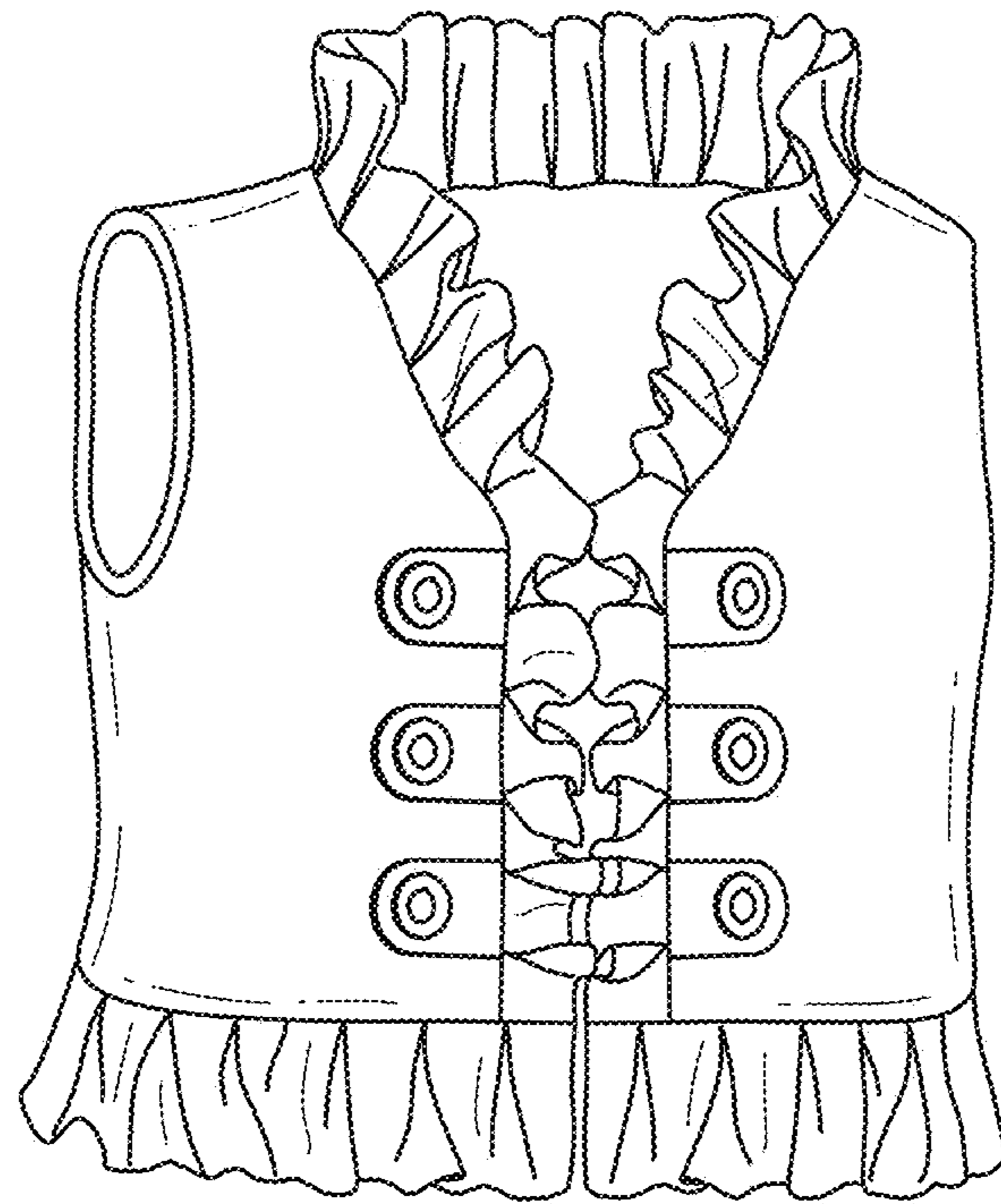

FIG. 1

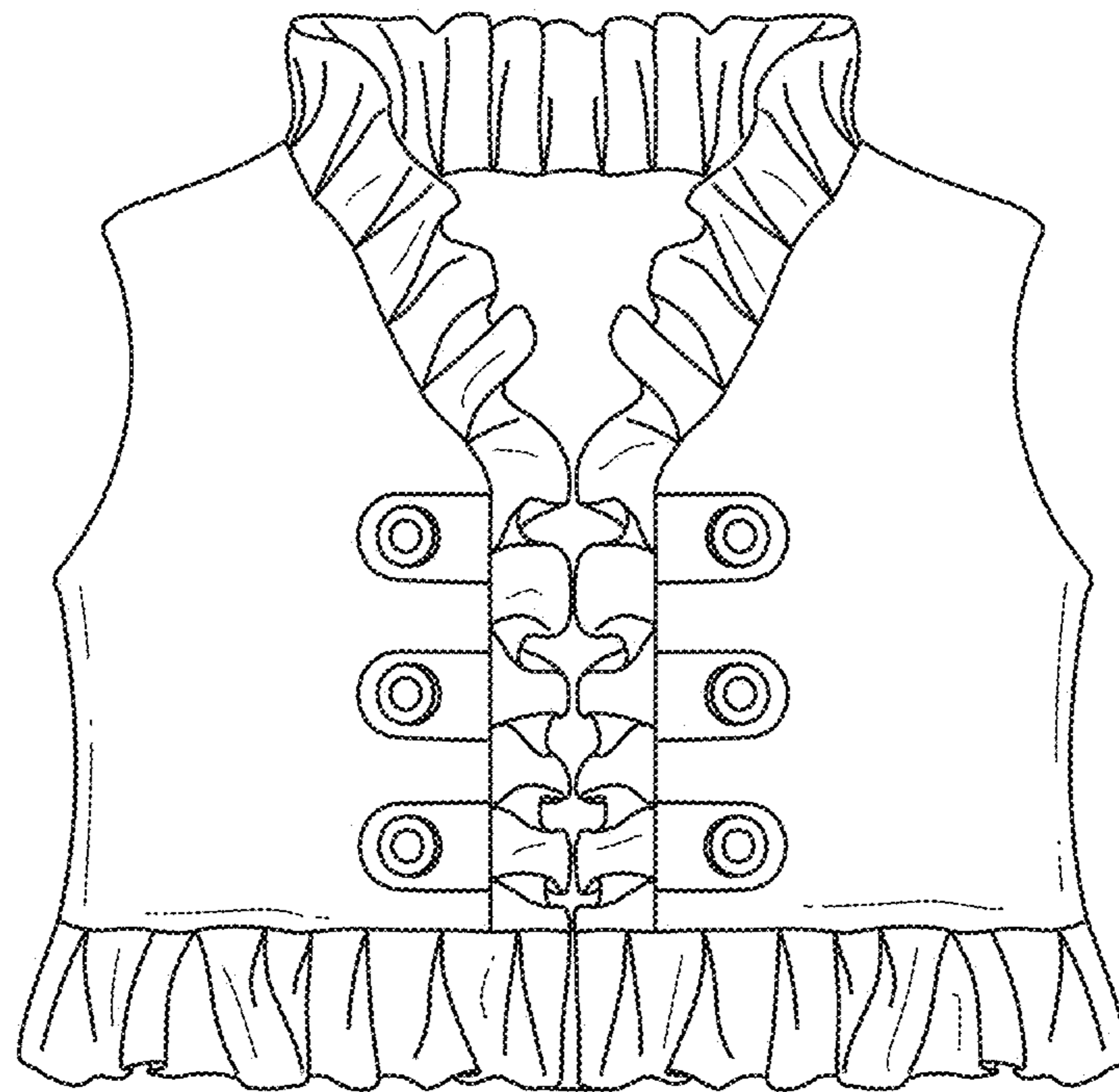

FIG. 2

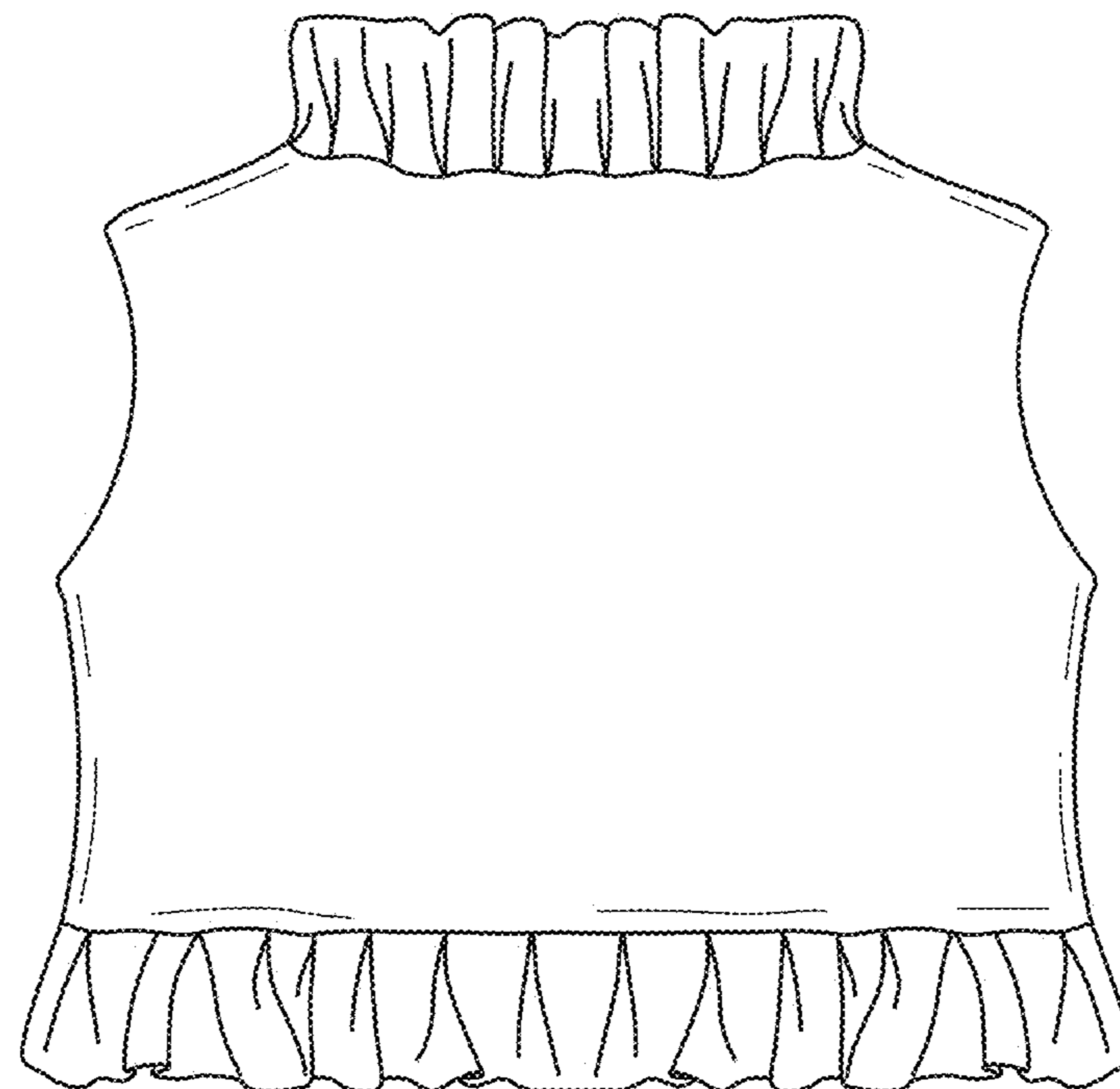

FIG. 3

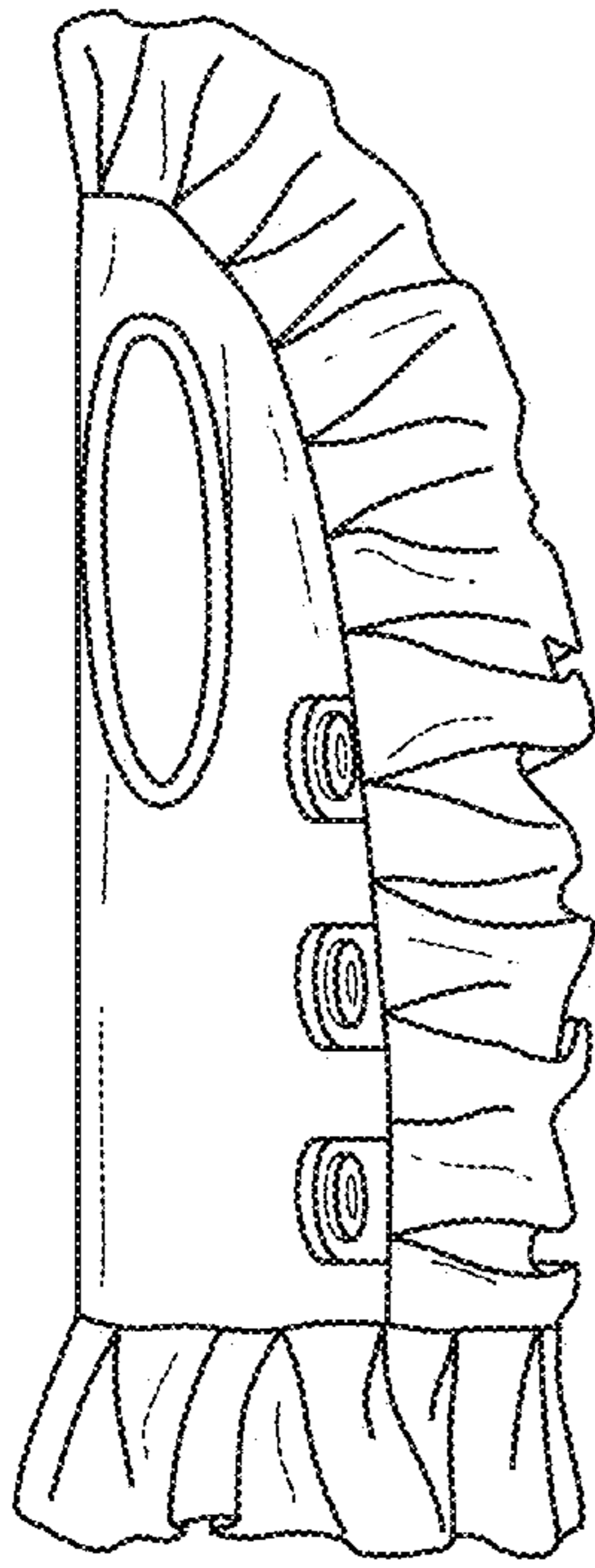

FIG. 4

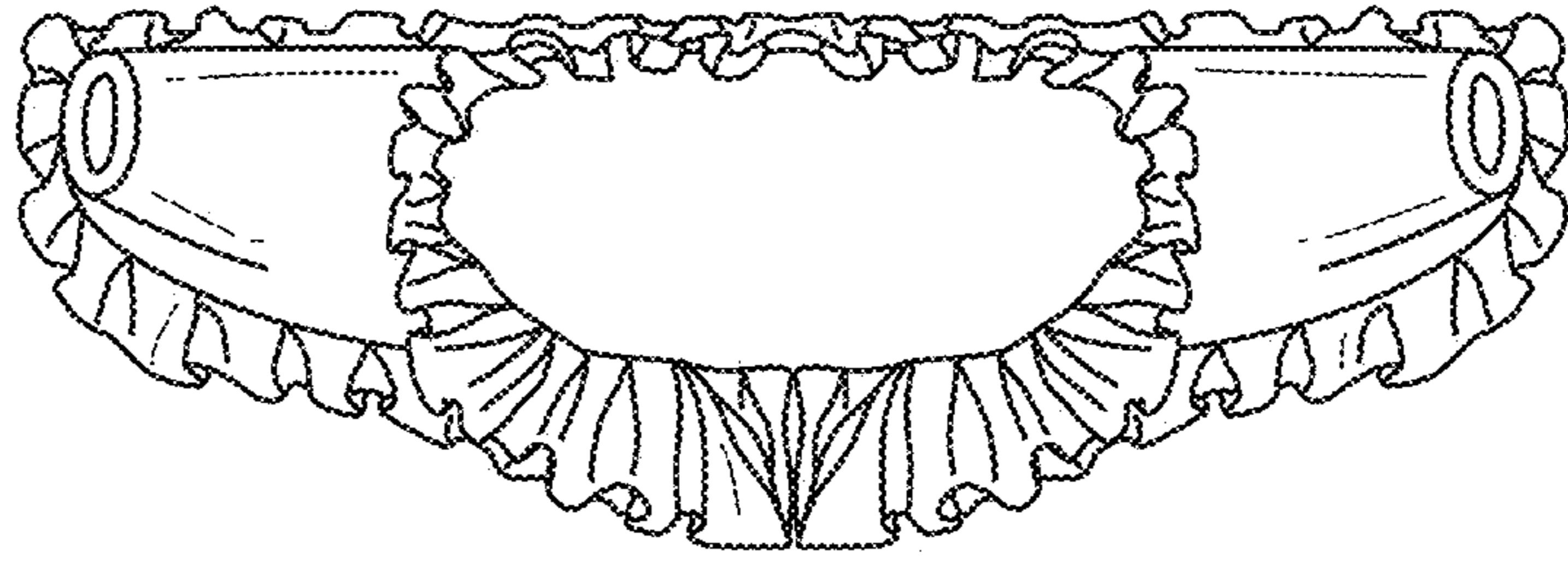

FIG. 5

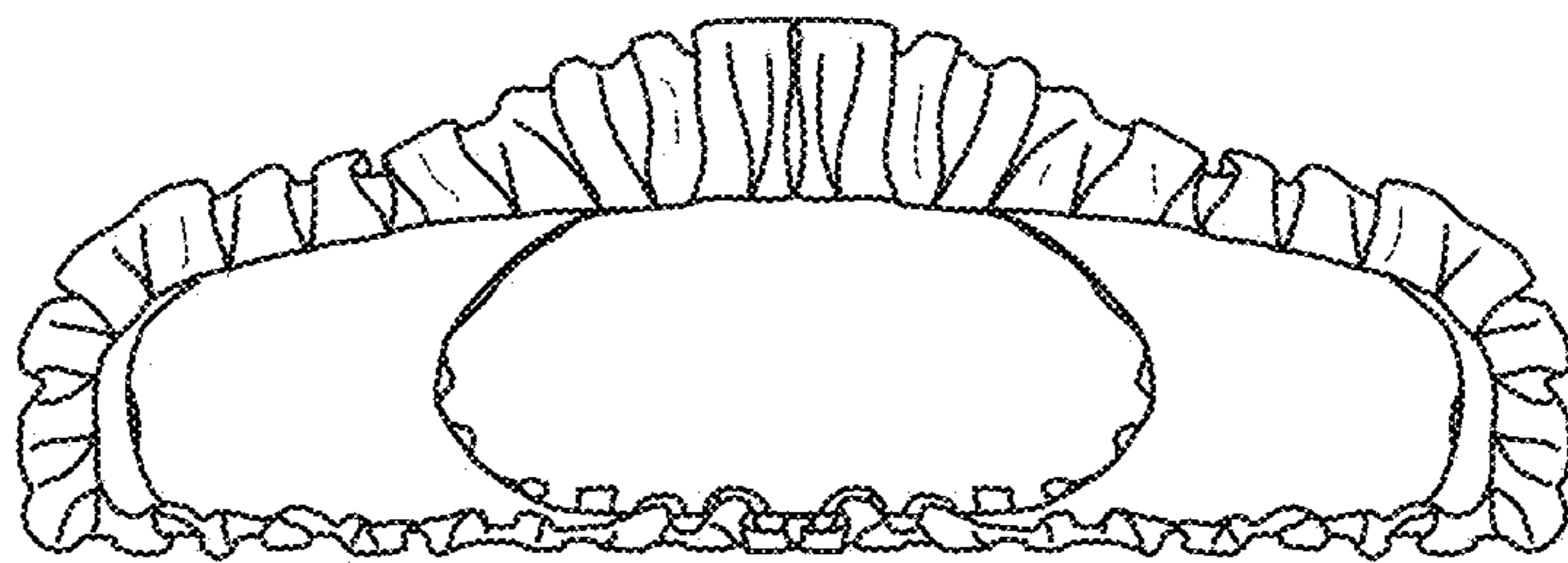

FIG. 6