



US00D934319S

(12) **United States Design Patent** (10) **Patent No.:** **US D934,319 S**
Krebs (45) **Date of Patent:** **** Oct. 26, 2021**

(54) **PACKAGING MATERIAL DISPENSER HEAD**

(74) *Attorney, Agent, or Firm* — Eversheds Sutherland (US) LLP

(71) Applicant: **Sprick GmbH Bielefelder Papier—und Wellpappenwerke & Co., Bielefeld (DE)**

(57) **CLAIM**

The ornamental design for a packaging material dispenser head, as shown and described.

(72) Inventor: **Vitali Krebs, Ahlen (DE)**

(73) Assignee: **SPRICK GMBH BIELEFELDER PAPIER—UND WELLPAPPENWERKE & CO., Bielefeld (DE)**

DESCRIPTION

The patent or application file contains at least one drawing executed in color. Copies of this patent or patent application with color drawing(s) will be provided by the U.S. Patent and Trademark Office upon request and payment of the necessary fee.

(**) Term: **15 Years**

(21) Appl. No.: **29/738,630**

FIG. 1 is a top perspective view of a packaging material dispenser head according to a first embodiment;

(22) Filed: **Jun. 18, 2020**

FIG. 2 is a front-side elevation view thereof, with the rear-side elevation view, left-side elevation view, and right-side elevation view being the same as FIG. 2;

Related U.S. Application Data

(62) Division of application No. 29/654,320, filed on Jun. 22, 2018, now Pat. No. Des. 889,521.

FIG. 3 is a top plan view thereof; and

FIG. 4 is a bottom plan view thereof.

Foreign Application Priority Data

Dec. 22, 2017 (EM) 004563112

FIG. 5 is a top perspective view of a packaging material dispenser head according to a second embodiment;

(51) **LOC (13) Cl.** **15-09**

FIG. 6 is a front-side elevation view thereof, with the rear-side elevation view, left-side elevation view, and right-side elevation view being the same as FIG. 6;

(52) **U.S. Cl.** **D15/145**

FIG. 7 is a top plan view thereof; and

(58) **Field of Classification Search** **D15/145**

FIG. 8 is a bottom plan view thereof.

USPC **D8/70; D7/700; D15/150, 145; D23/225, 213**

FIG. 9 is a top perspective view of a packaging material dispenser head according to a third embodiment;

(Continued)

FIG. 10 is a front-side elevation view thereof, with the rear-side elevation view, left- side elevation view, and right-side elevation view being the same as FIG. 10;

References Cited

(56) **References Cited**

U.S. PATENT DOCUMENTS

D279,323 S 6/1985 Spenceley
D303,265 S * 9/1989 Miyoshi D15/122

FIG. 11 is a top plan view thereof; and,

(Continued)

FIG. 12 is a bottom plan view thereof.

The broken lines shown on the drawings depict portions of the packaging material dispenser head that form no part of the claimed design. The dash-dot-dash lines define the bounds of the claimed design and form no part thereof.

Primary Examiner — Philip S Hyder

1 Claim, 12 Drawing Sheets
(8 of 12 Drawing Sheet(s) Filed in Color)

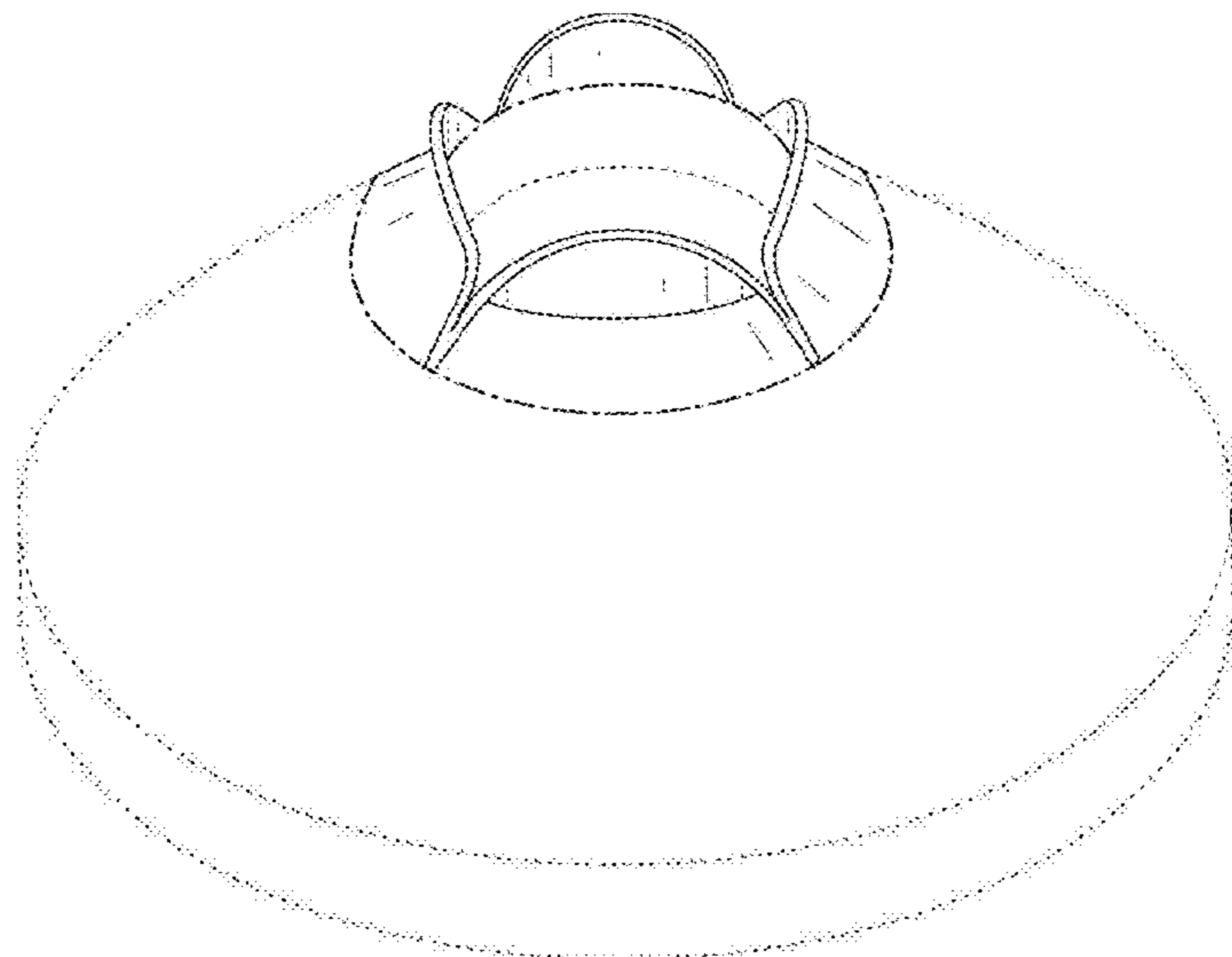

(58) **Field of Classification Search**
 CPC B31D 5/0039; B31D 2205/0029; B65H
 16/005; B65H 35/008; B65H 2701/1944;
 A47K 2010/3266
 See application file for complete search history.

D738,169 S	9/2015	Weisenbach	
D763,335 S *	8/2016	Ruffin	D15/150
D778,970 S *	2/2017	Levy	D15/150
D790,662 S	6/2017	Legatt et al.	
9,937,682 B2 *	4/2018	Schmid	B65H 16/005
D847,303 S	4/2019	Becker et al.	
2007/0117703 A1 *	5/2007	Cavaliere, Jr.	B31D 5/0052 493/464
2008/0076653 A1	3/2008	Shaw et al.	
2011/0079321 A1	4/2011	Mattson	
2012/0053033 A1 *	3/2012	Sprick-Schuette ..	B31D 5/0043 493/38
2013/0313338 A1 *	11/2013	Liang	B05B 7/2413 239/310
2014/0116514 A1 *	5/2014	Tix	B05C 11/1047 137/1
2015/0330089 A1 *	11/2015	Finstad	B05B 7/2478 239/8
2017/0100906 A1	4/2017	Beaver et al.	

(56) **References Cited**
 U.S. PATENT DOCUMENTS

D346,851 S	5/1994	Howe	
D415,662 S *	10/1999	Schneider	D7/691
D449,105 S *	10/2001	Azo	D24/122
D474,528 S *	5/2003	Huang	D23/225
7,025,301 B1 *	4/2006	Notarnicola	A47K 10/3818 242/593
D541,116 S *	4/2007	Upham	D7/700
D542,610 S *	5/2007	Silverman	D7/700
D554,741 S	11/2007	Peterson et al.	
8,210,449 B2	7/2012	Peterson et al.	
D728,327 S *	5/2015	Wirth	D7/700

* cited by examiner

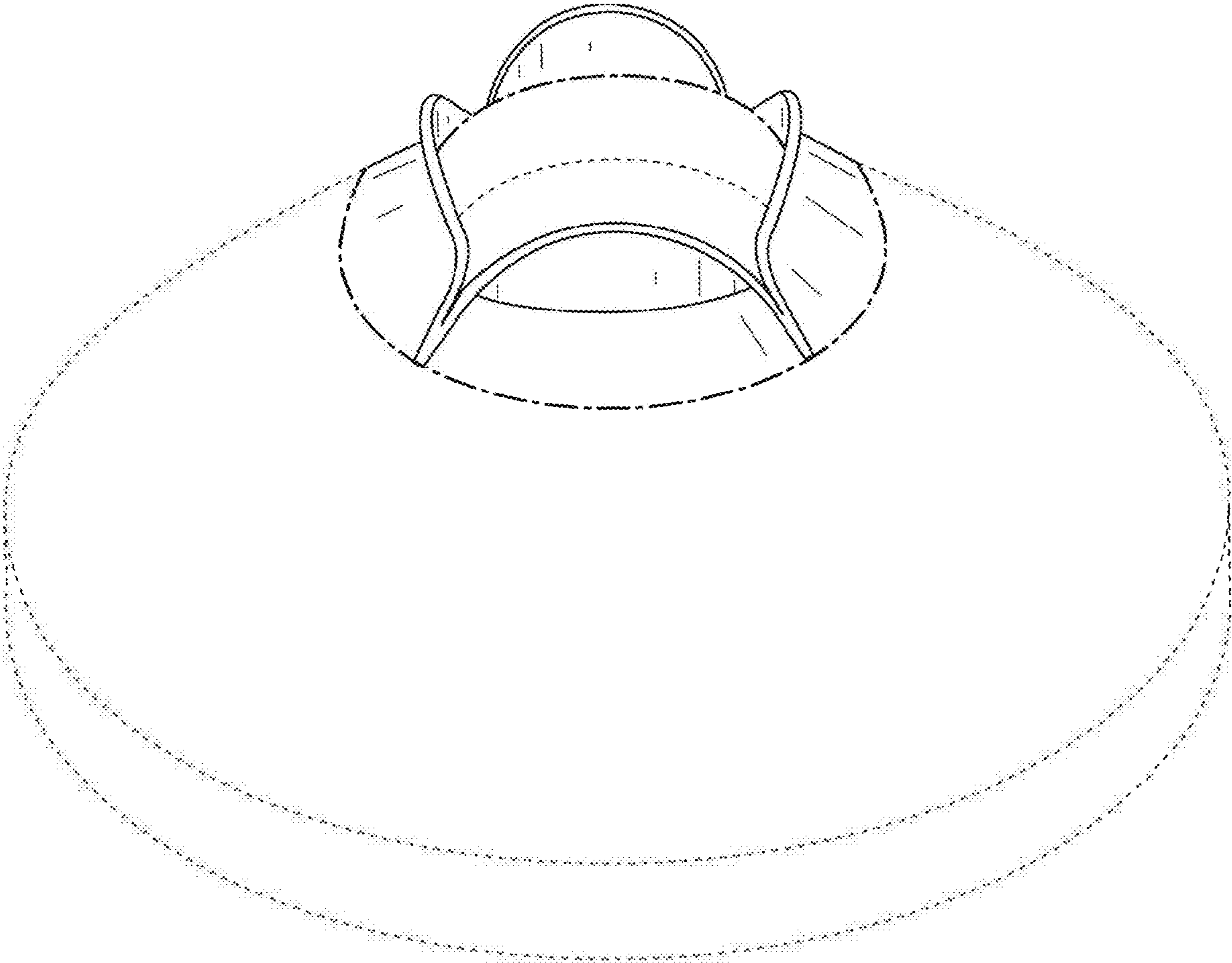
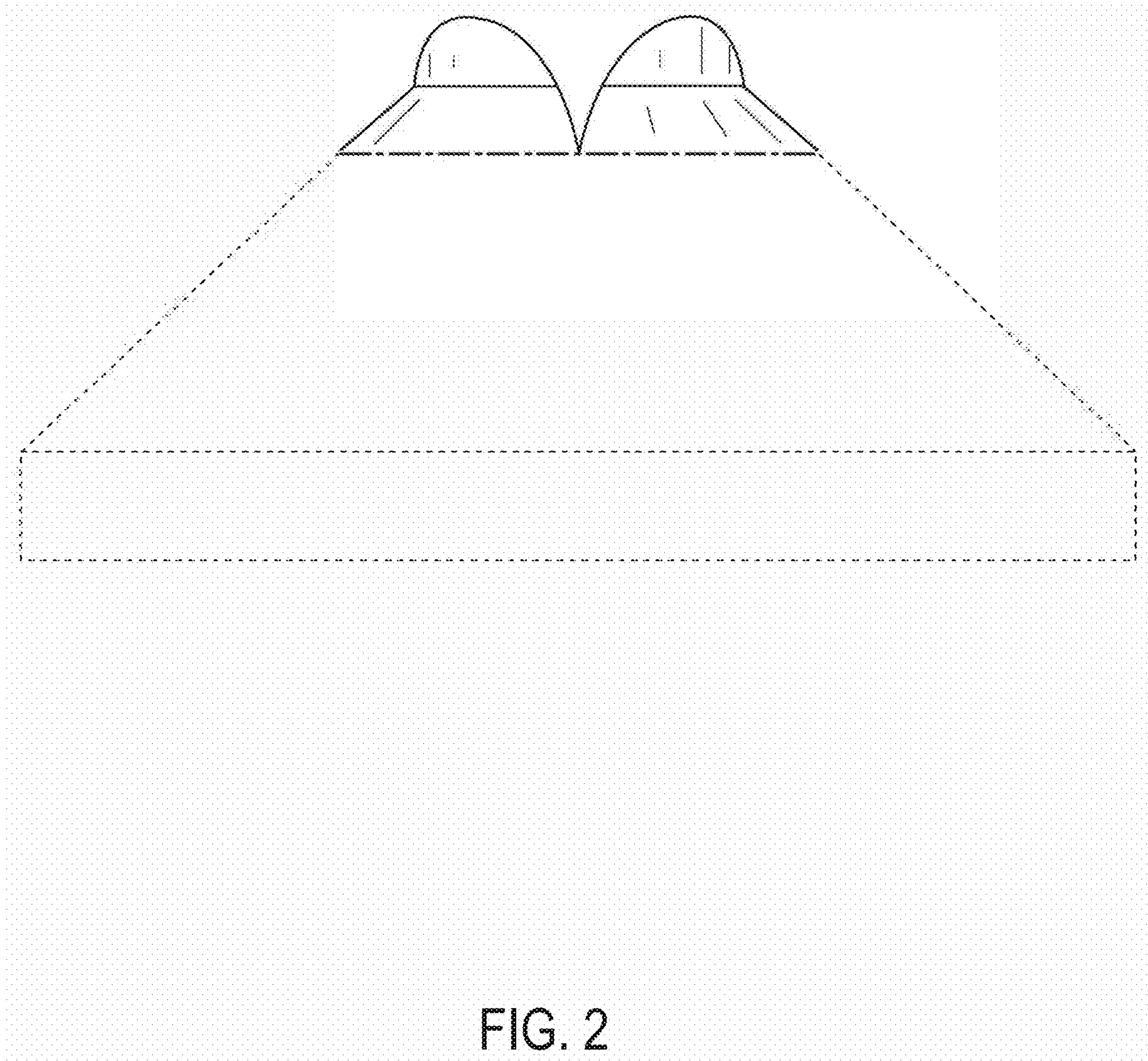

FIG. 1



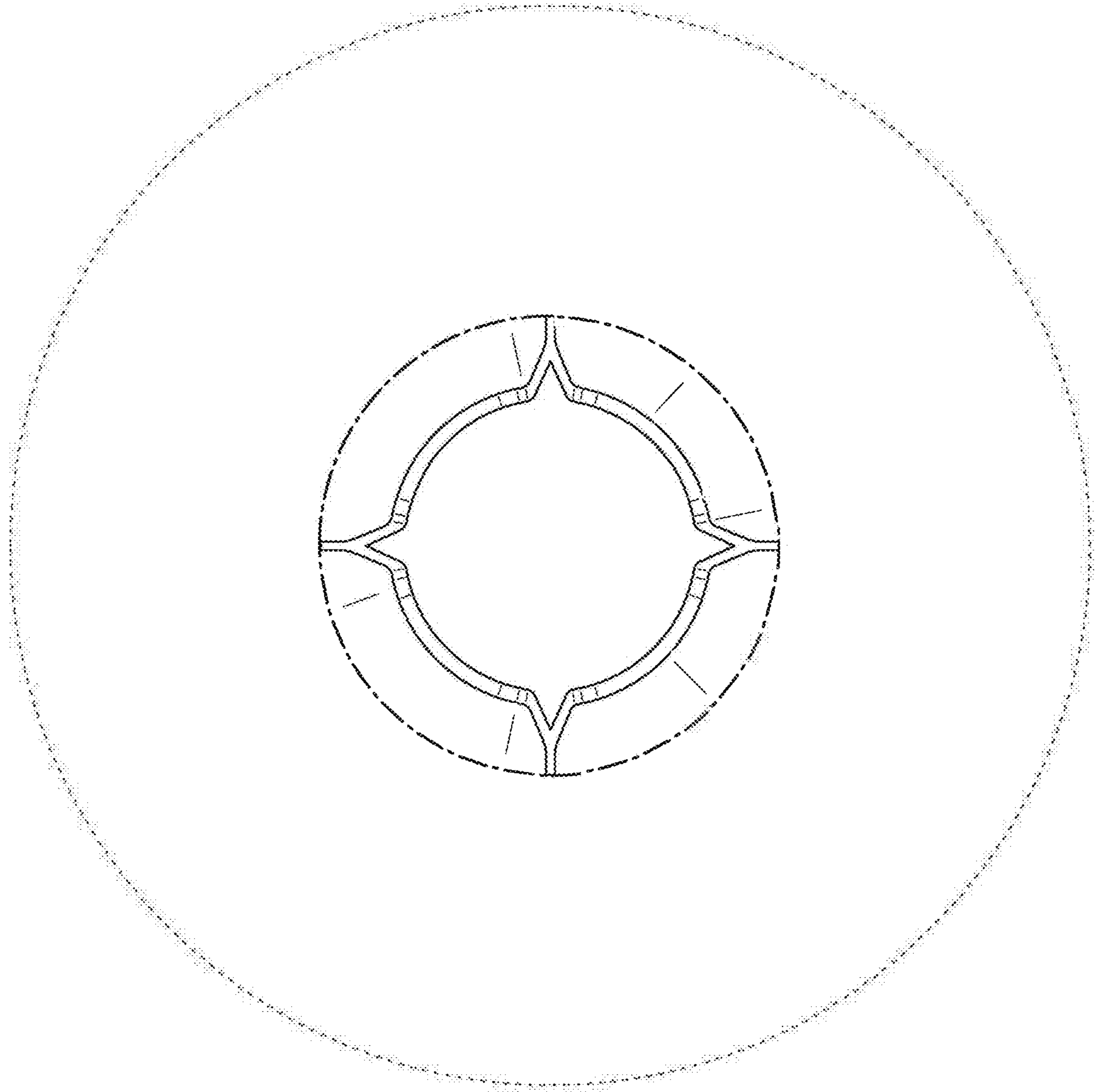

FIG. 3

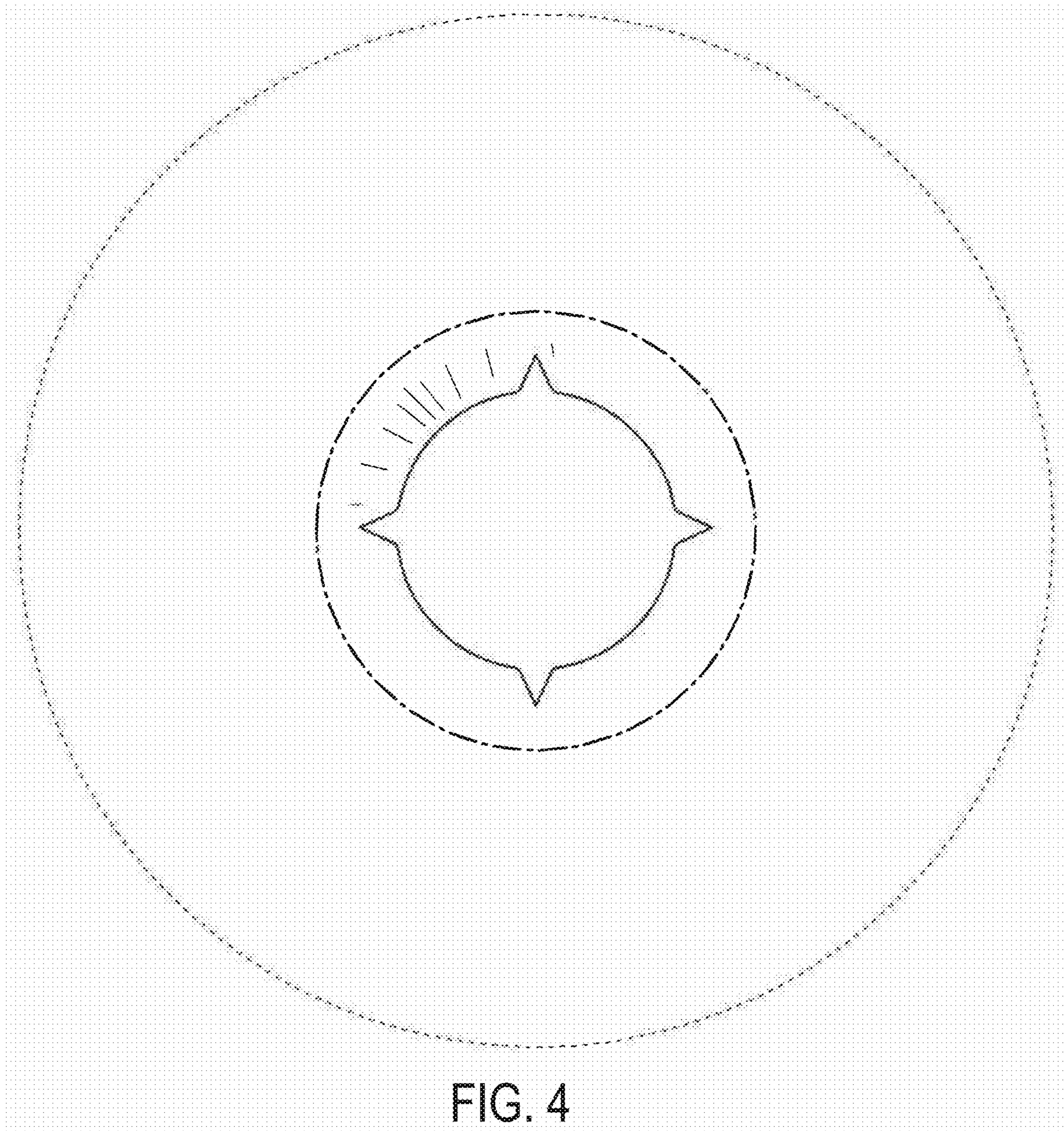

FIG. 4

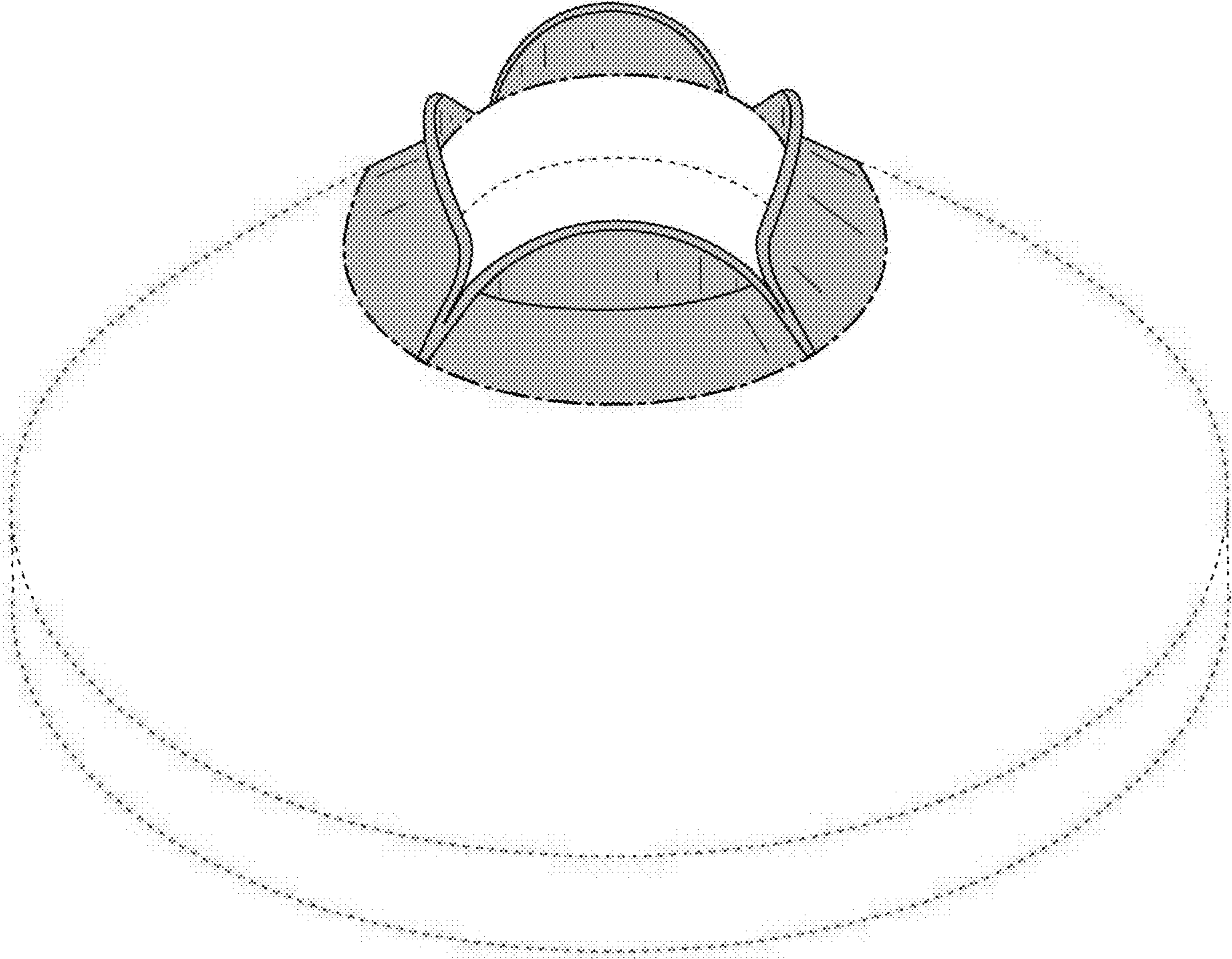

FIG. 5

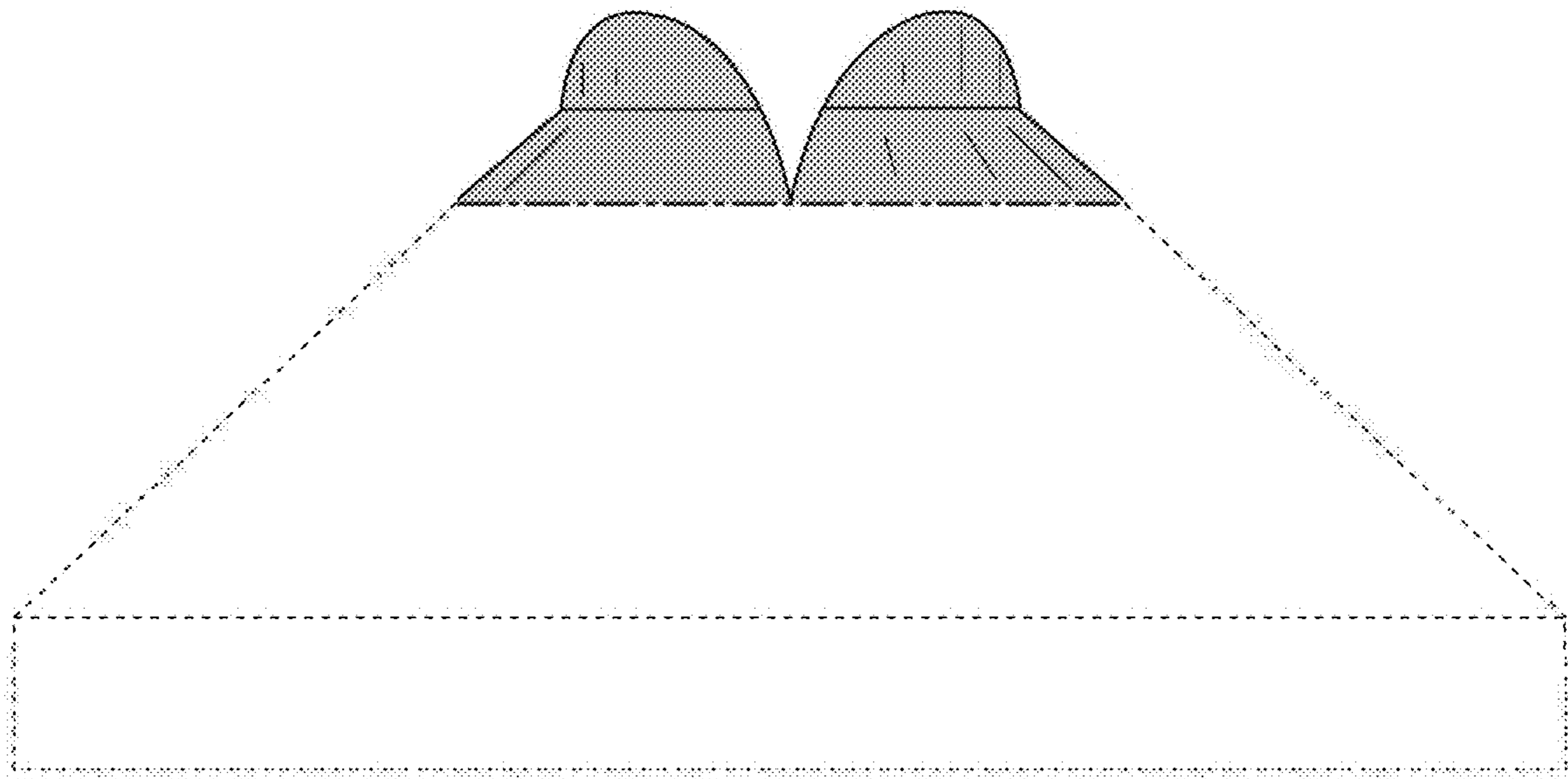

FIG. 6

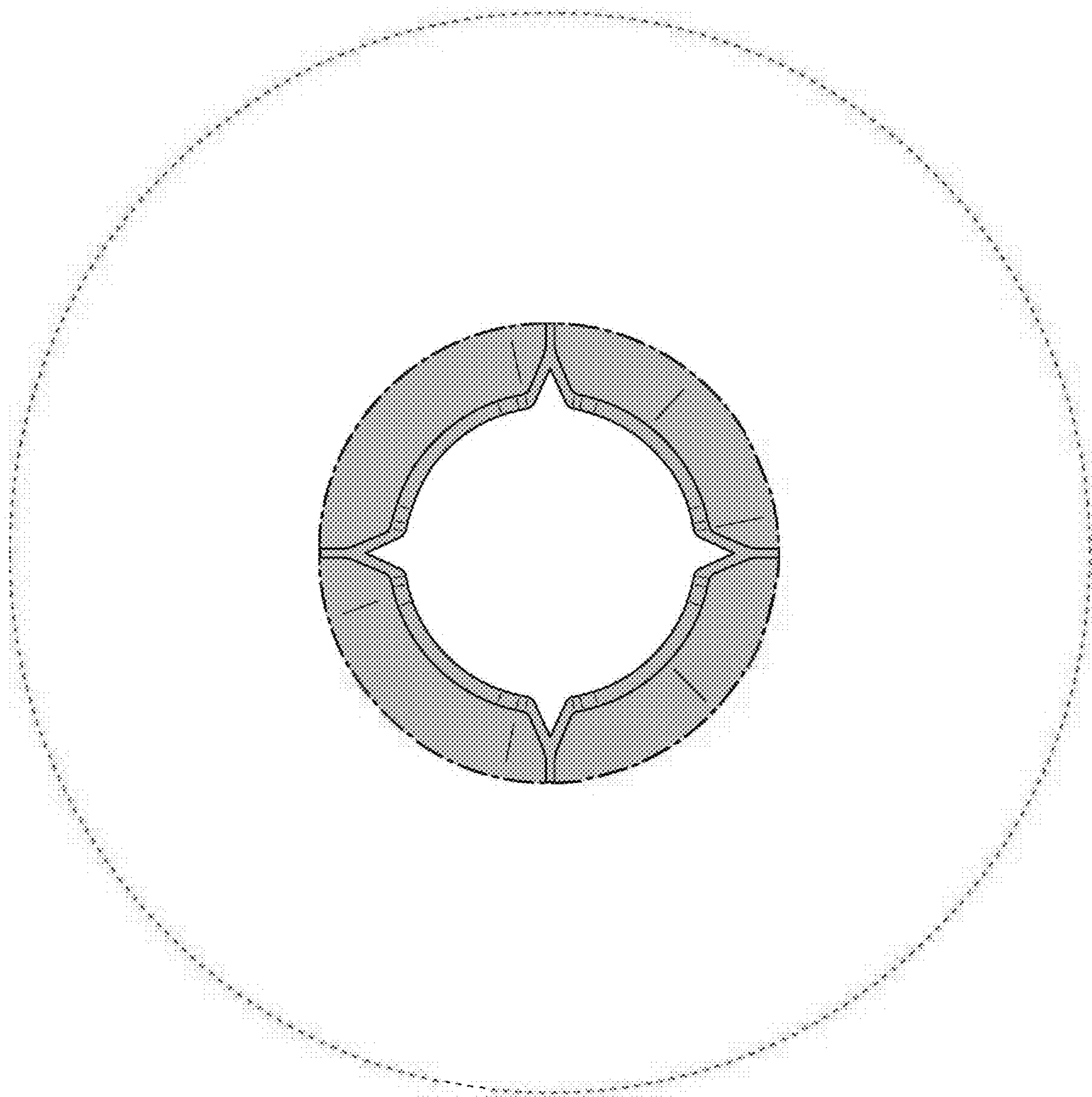

FIG. 7

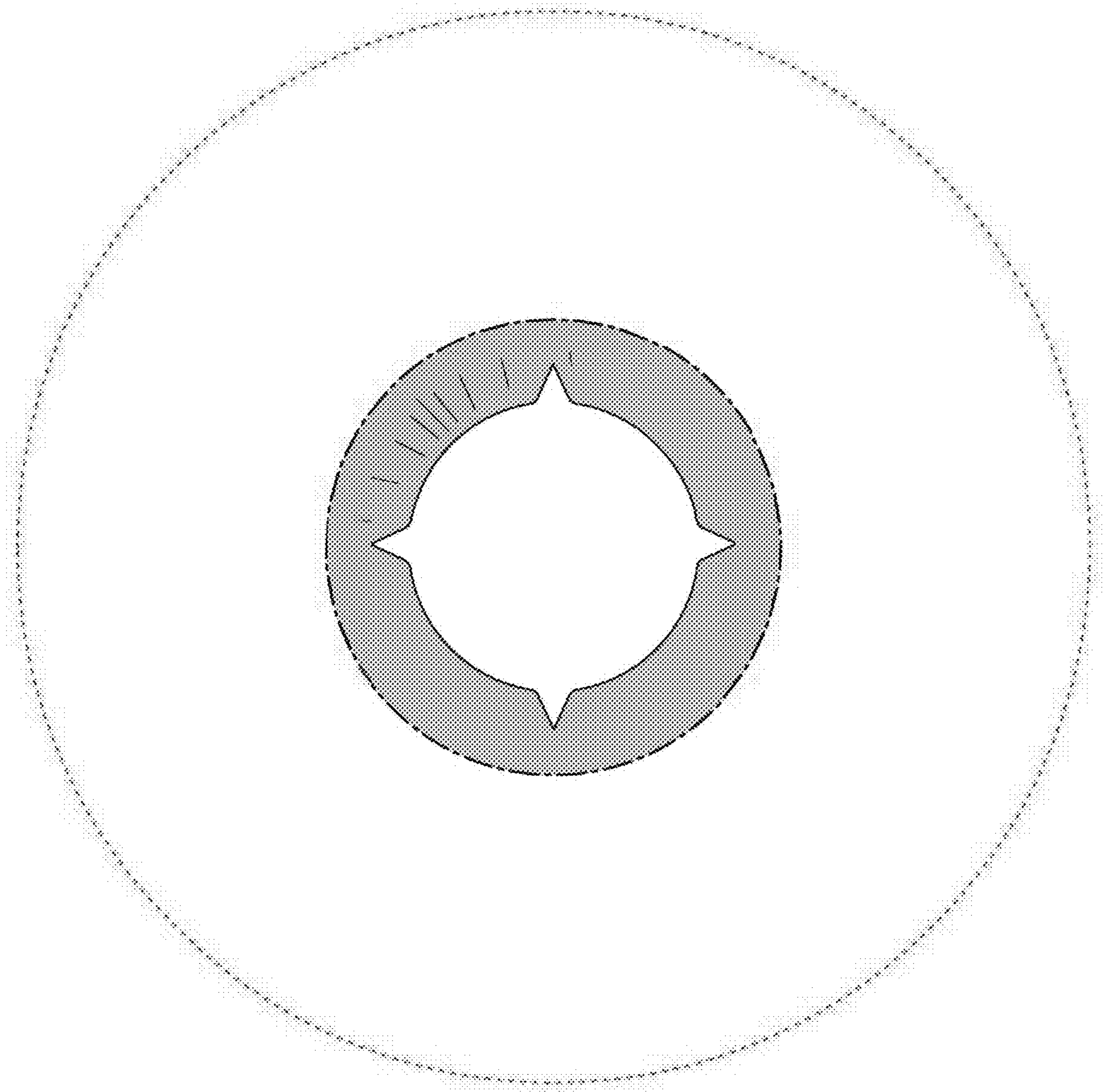

FIG. 8

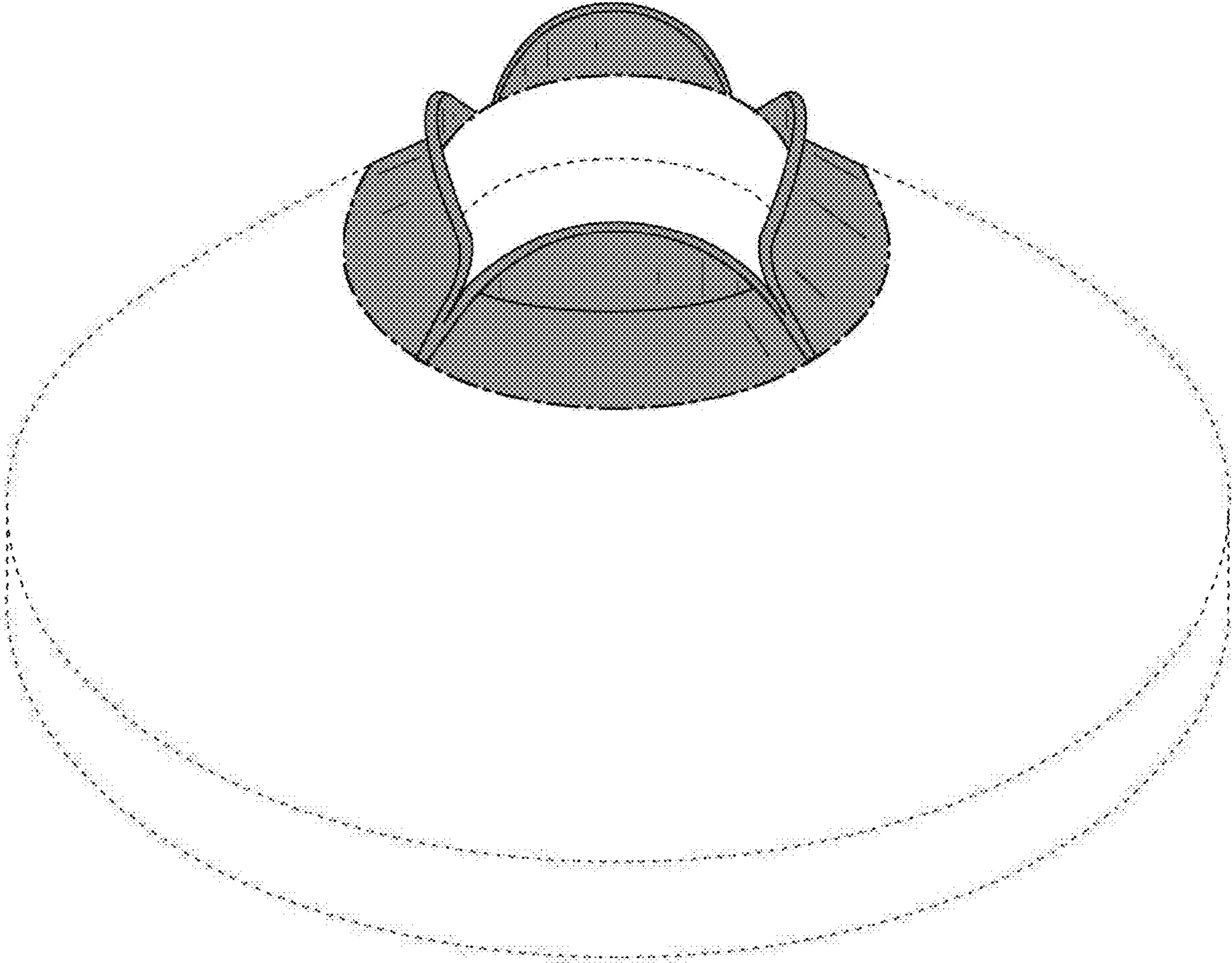

FIG. 9

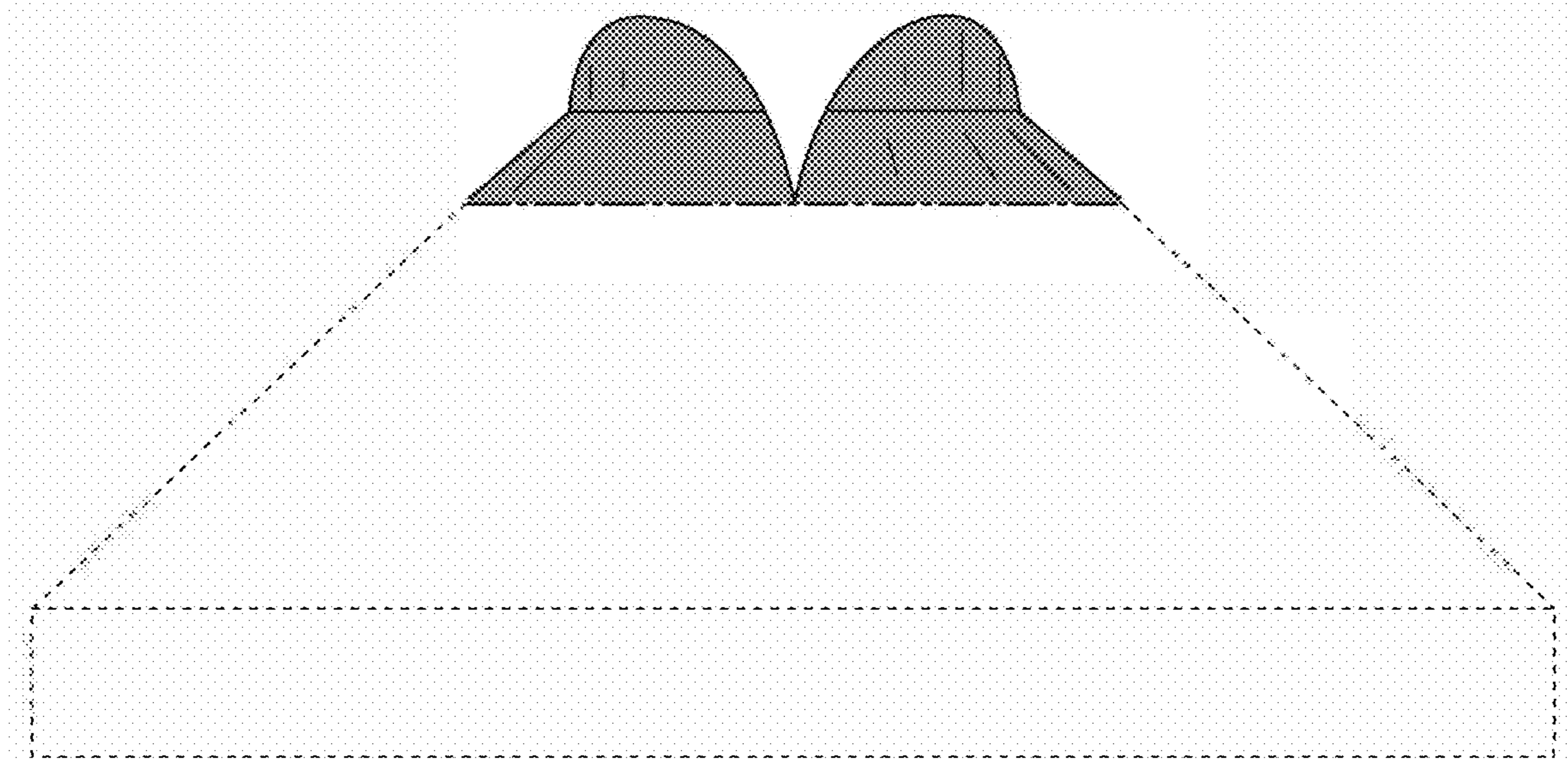

FIG. 10

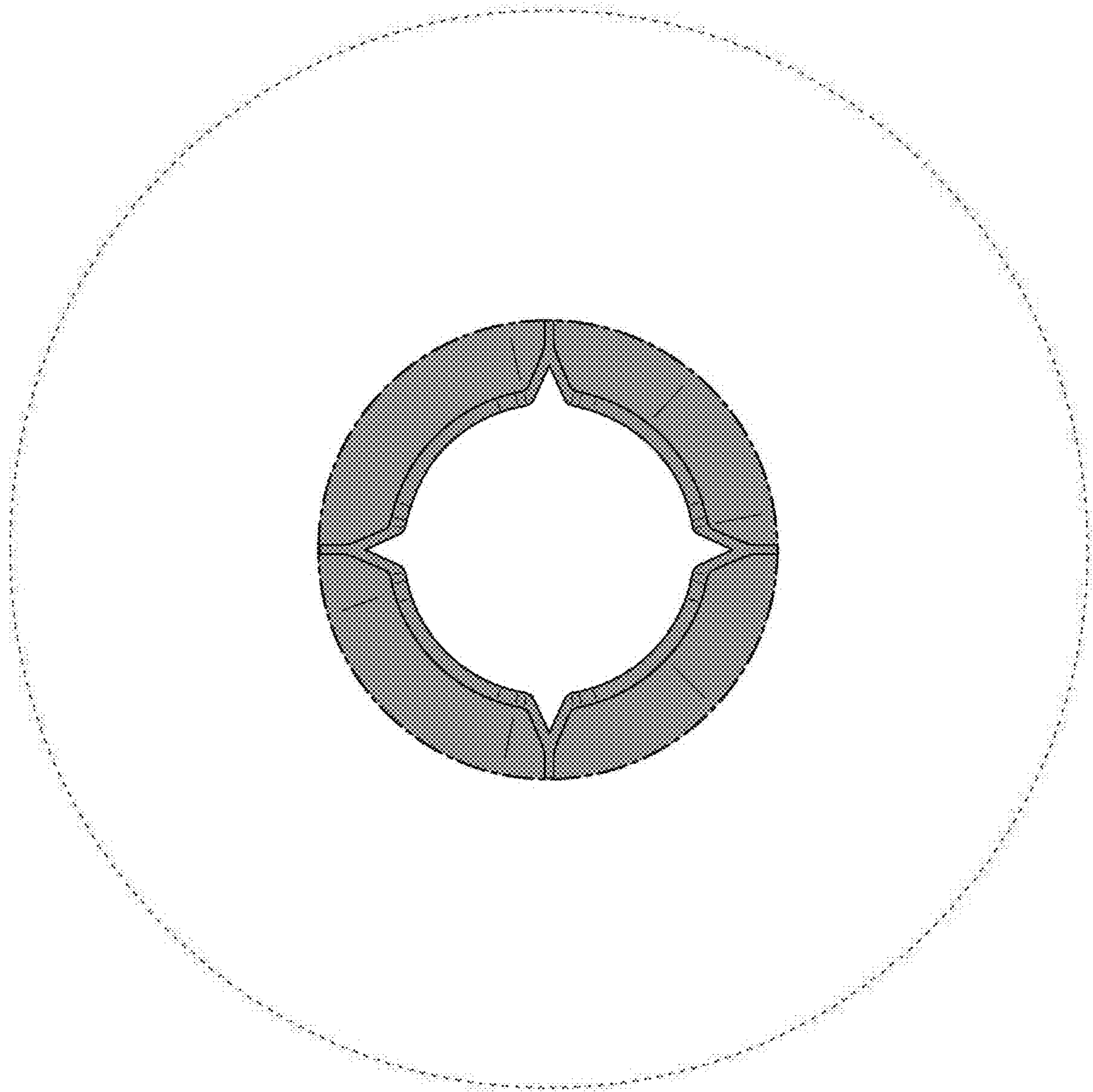

FIG. 11

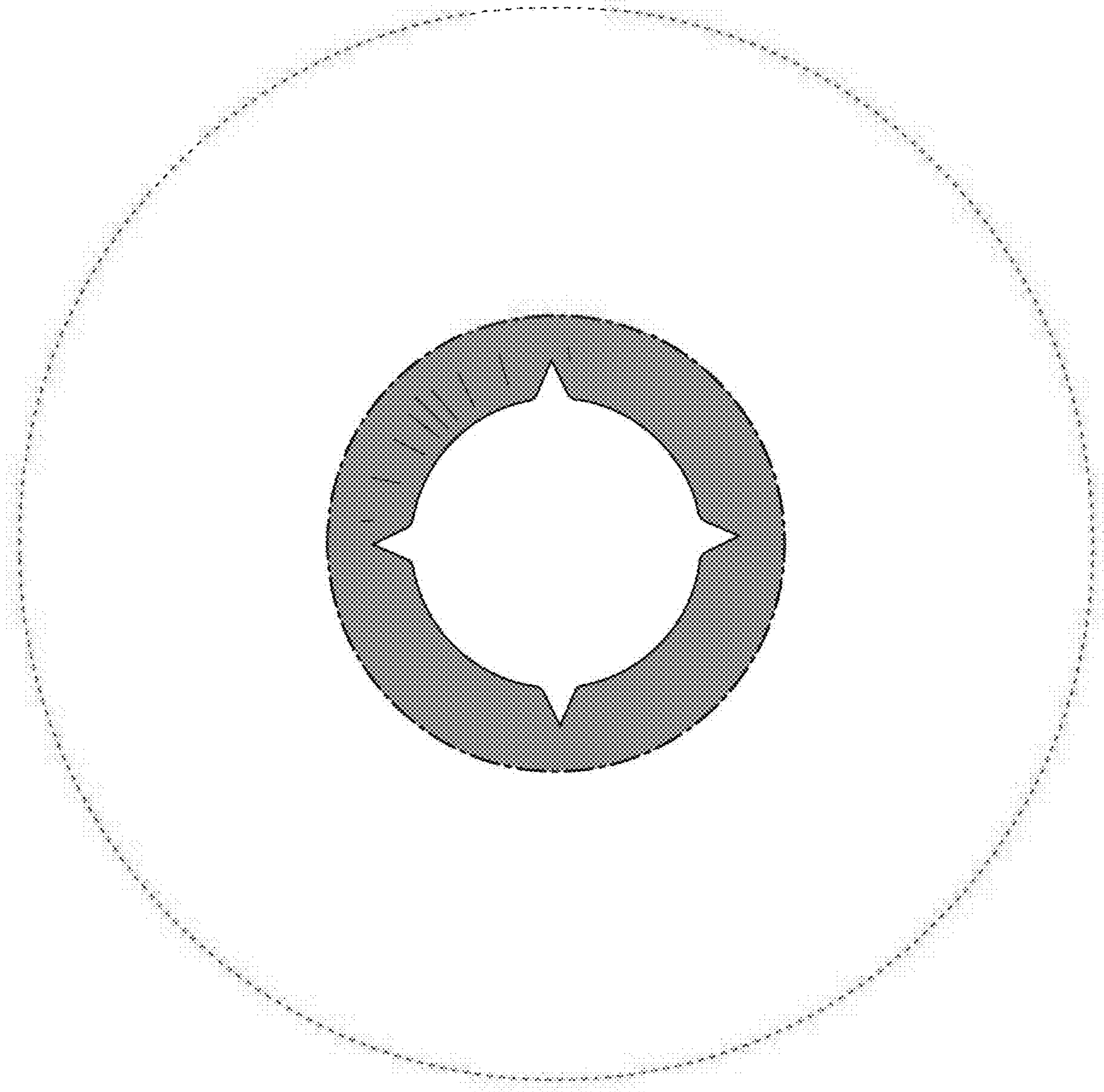

FIG. 12