



US00D934174S

(12) **United States Design Patent** (10) **Patent No.:** **US D934,174 S**  
**Protti** (45) **Date of Patent:** **\*\* Oct. 26, 2021**

(54) **VEHICLE BATTERY CLAMP**  
(71) Applicant: **Innova Electronics Corporation,**  
Irvine, CA (US)  
(72) Inventor: **John Protti,** Irvine, CA (US)  
(73) Assignee: **Innova Electronics Corporation,**  
Irvine, CA (US)  
(\*\*) Term: **15 Years**  
(21) Appl. No.: **29/726,494**  
(22) Filed: **Mar. 3, 2020**  
(51) **LOC (13) Cl.** ..... **13-02**  
(52) **U.S. Cl.**  
USPC ..... **D13/120**  
(58) **Field of Classification Search**  
USPC ..... D8/395; D13/102–106, 110, 119–121,  
D13/184, 199  
CPC ..... H01R 11/24; H01R 11/281; H01R 11/282;  
H01R 11/286  
See application file for complete search history.

D746,774 S \* 1/2016 Nook ..... D13/120  
2002/0144381 A1\* 10/2002 Olivares ..... H01R 11/24  
24/499  
2017/0373410 A1\* 12/2017 Lipkin ..... H01R 11/24

\* cited by examiner  
*Primary Examiner* — Jennifer O King  
(74) *Attorney, Agent, or Firm* — Stetina Brunda Garred & Brucker

(57) **CLAIM**  
The ornamental design for a vehicle battery clamp, as shown and described.

**DESCRIPTION**  
FIG. 1 is a rear upper perspective view the vehicle battery clamp showing our new design;  
FIG. 2 is a front upper perspective view thereof;  
FIG. 3 is a top plan view thereof;  
FIG. 4 is a right-side elevational view thereof;  
FIG. 5 is a left-side elevational view thereof;  
FIG. 6 is a bottom plan view thereof;  
FIG. 7 is a front elevational view thereof; and,  
FIG. 8 is a rear elevational view thereof.  
The broken lines shown represent portions of the vehicle battery clamp that form no part of the claimed design. The additional broken lines shown in FIGS. 1 and 2 display environment.

(56) **References Cited**  
U.S. PATENT DOCUMENTS  
D258,818 S \* 4/1981 Johnson ..... D13/120  
D442,047 S \* 5/2001 Hicks ..... D8/395  
D597,029 S \* 7/2009 Li ..... D13/120  
D738,825 S \* 9/2015 Nook ..... D13/120

**1 Claim, 4 Drawing Sheets**

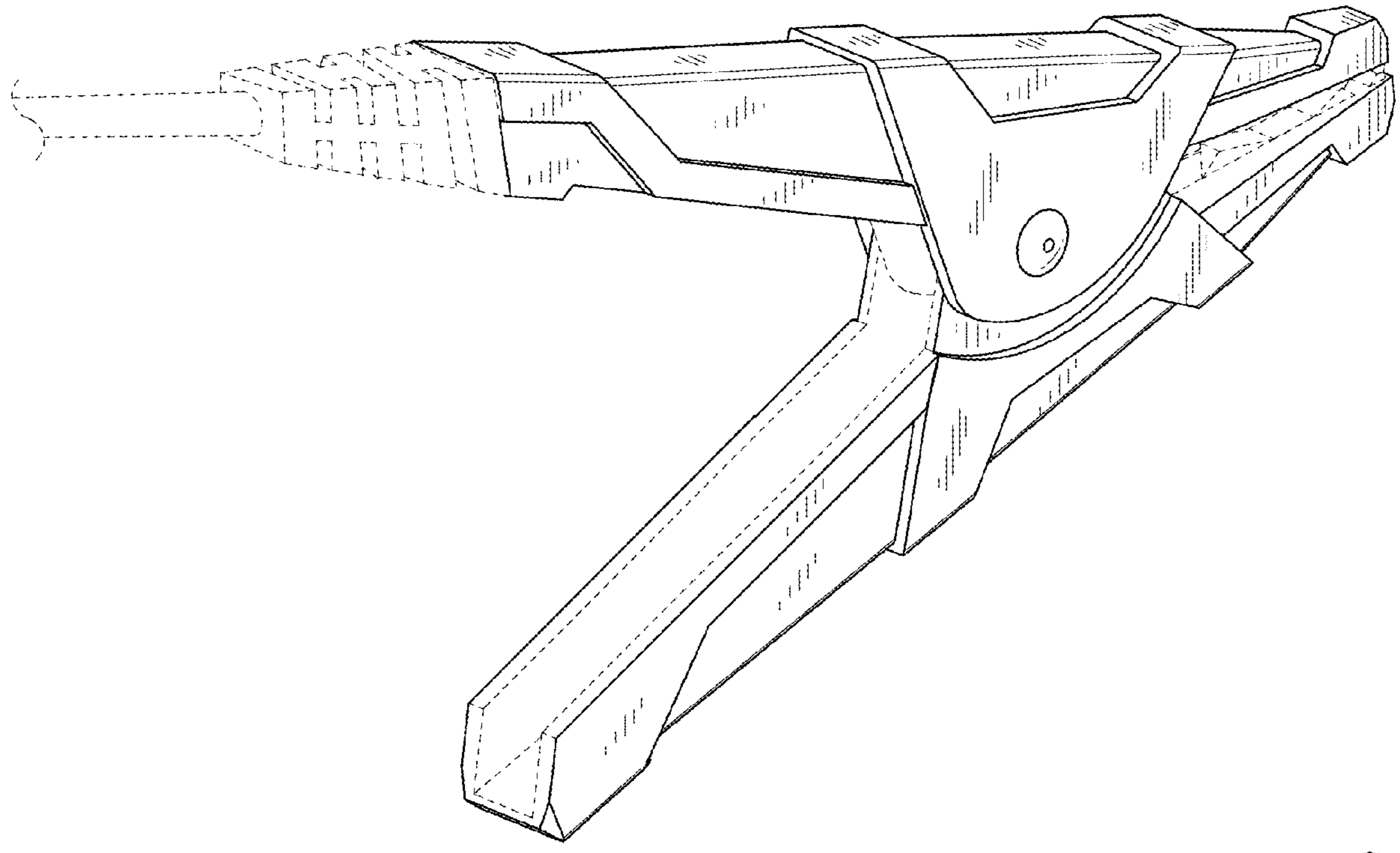

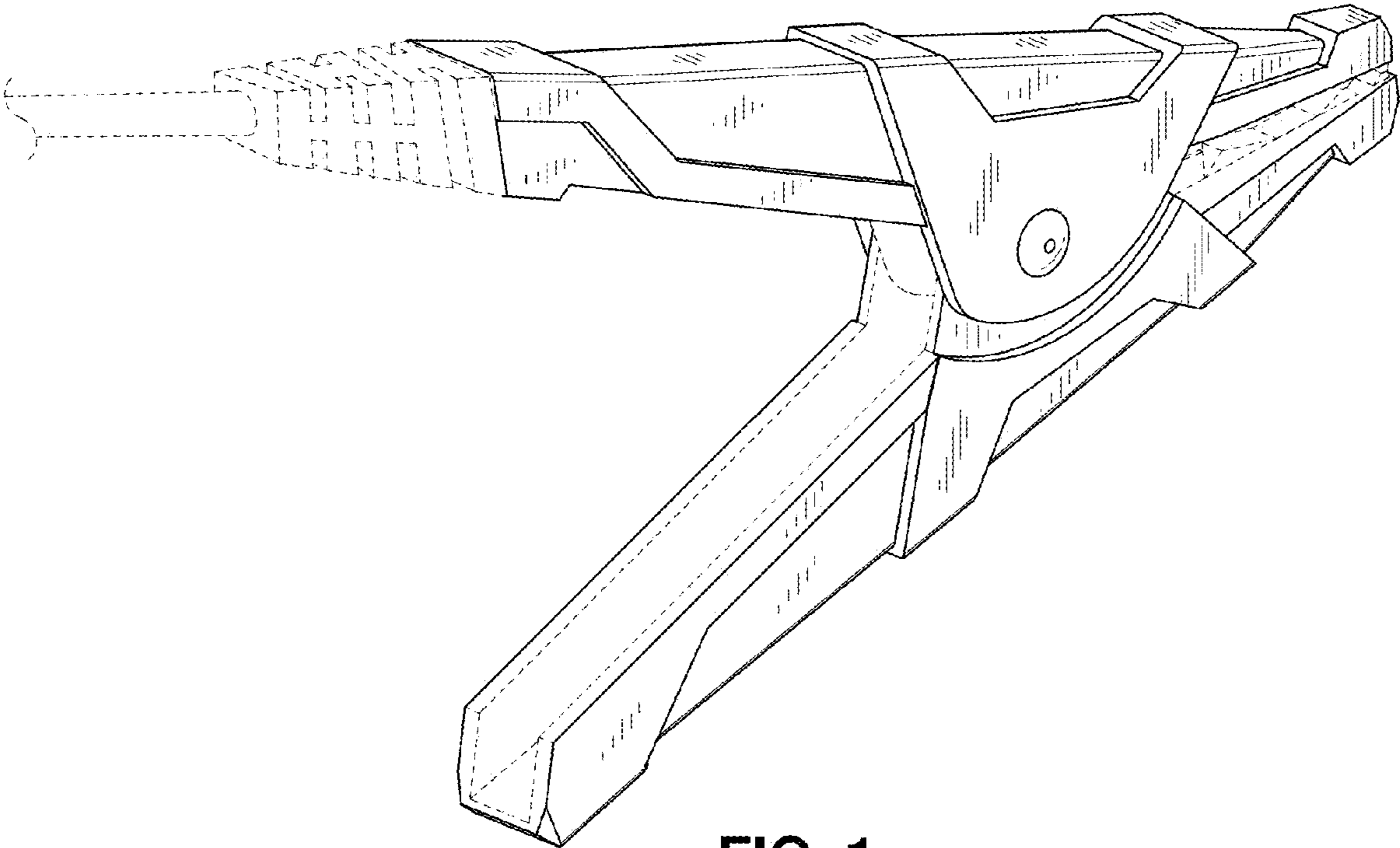

FIG. 1

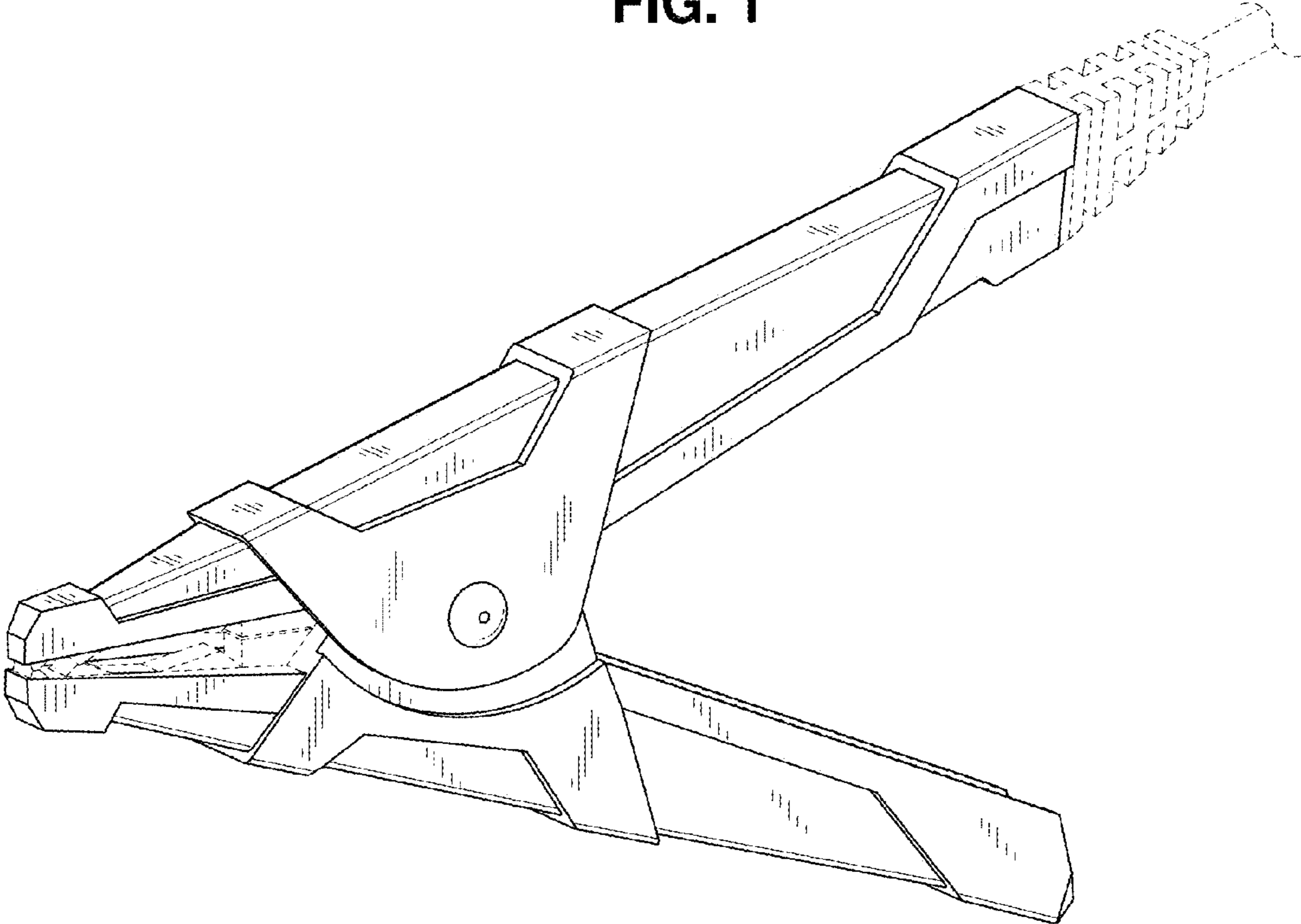
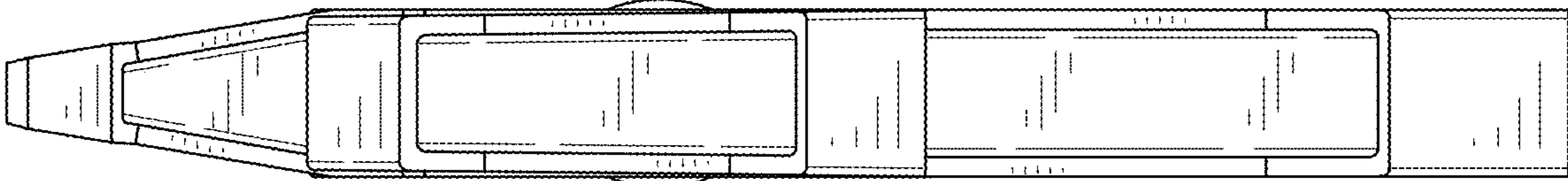
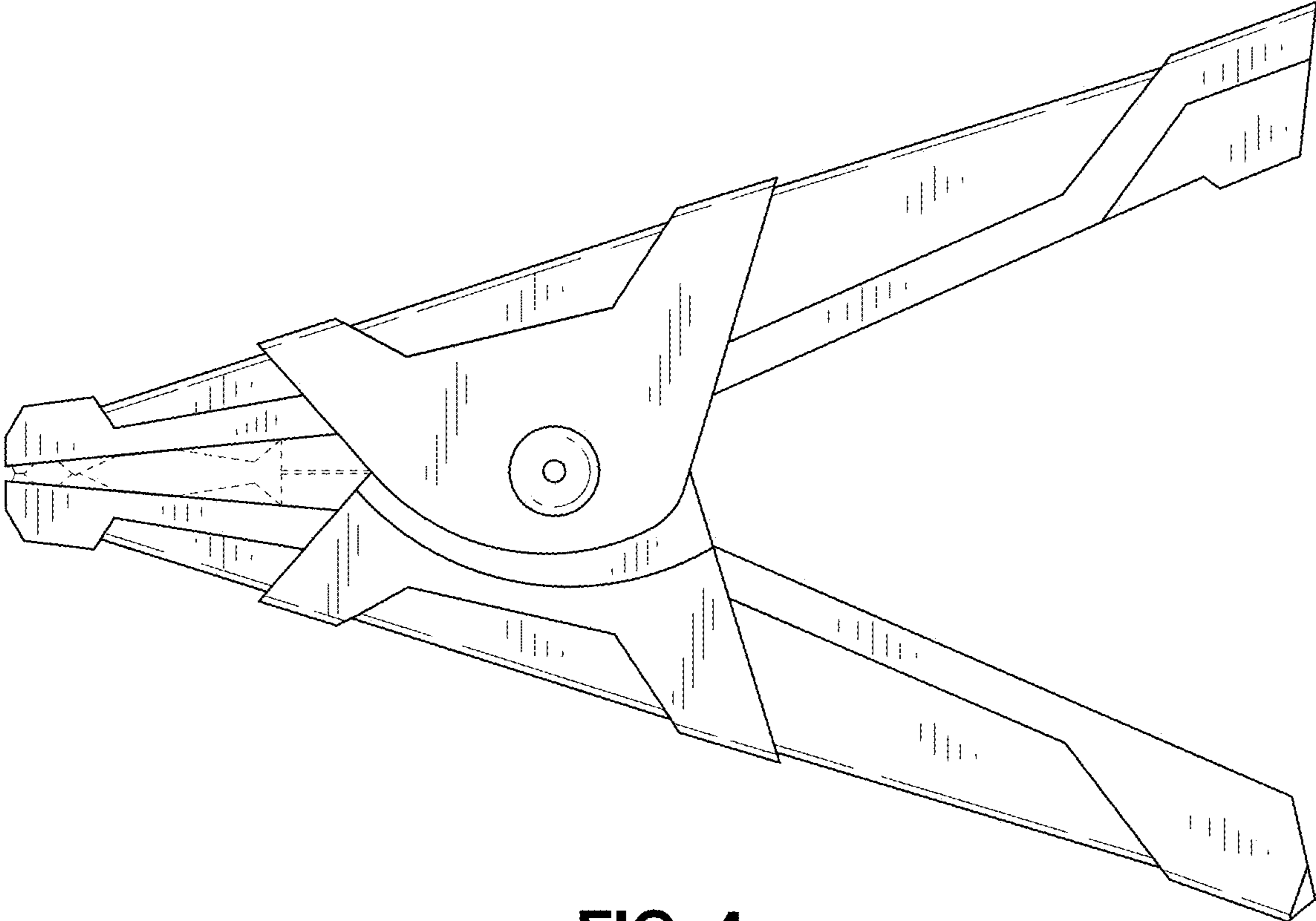

FIG. 2



**FIG. 3**



**FIG. 4**

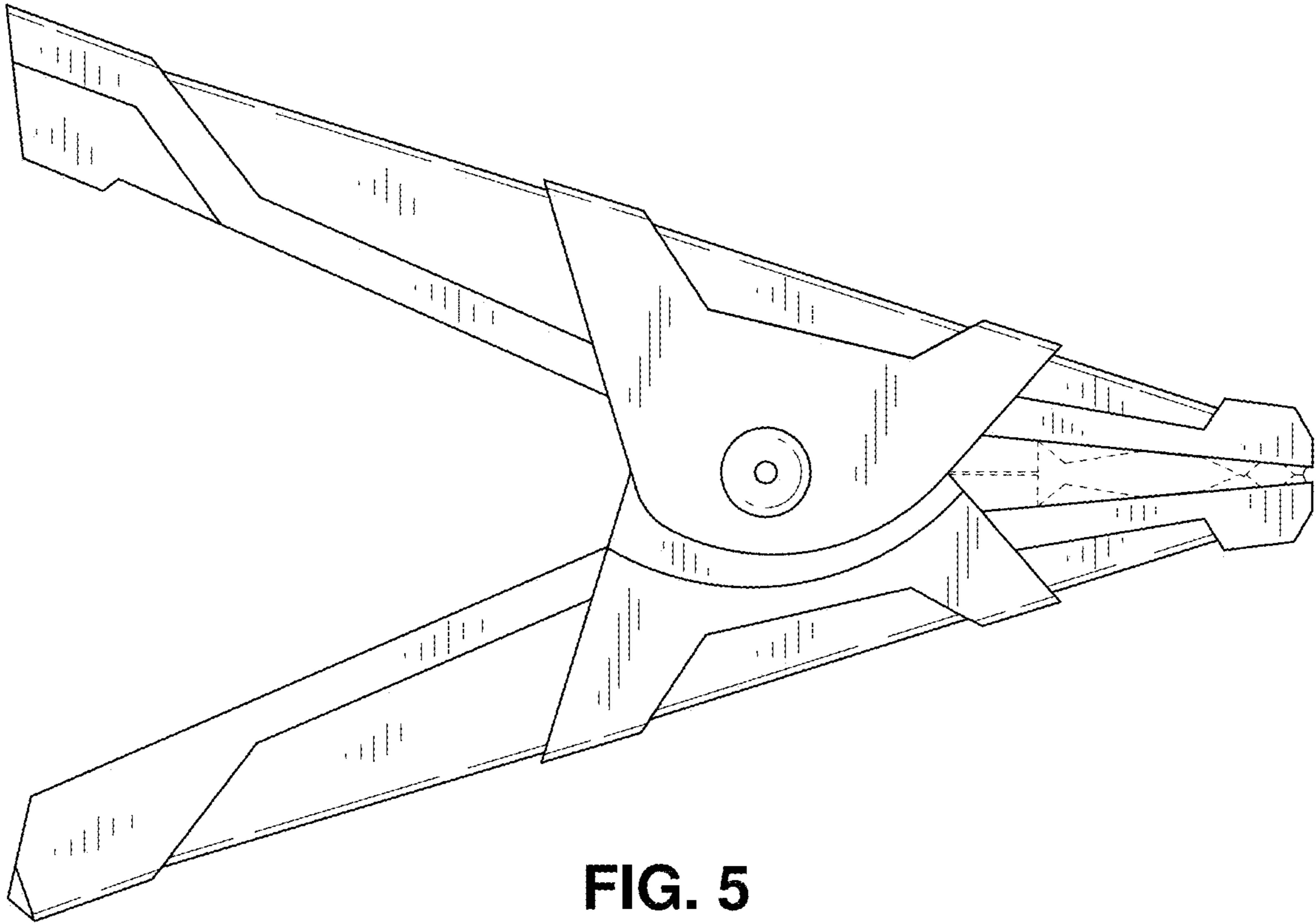

FIG. 5

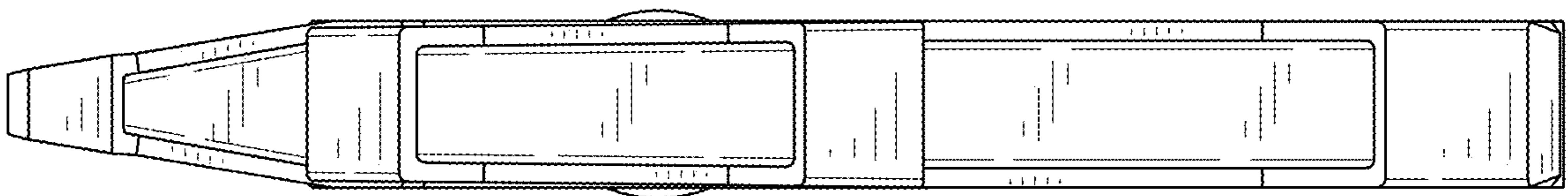

FIG. 6

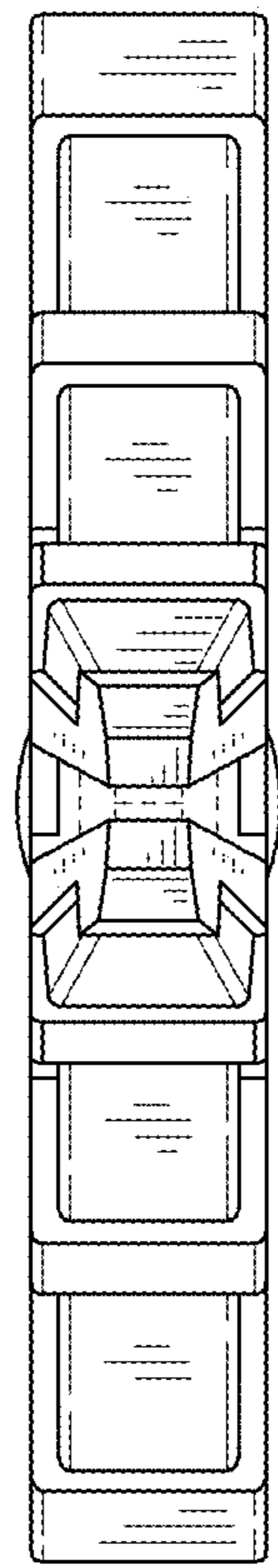

FIG. 7

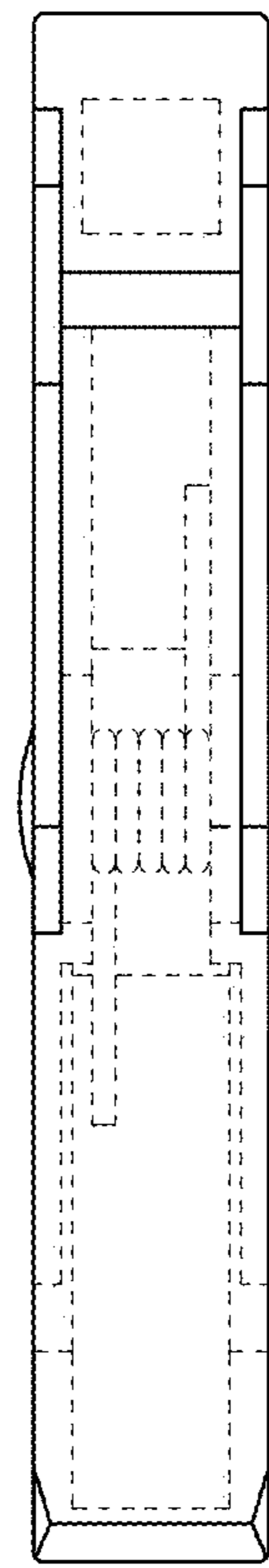

FIG. 8