



US00D933789S

(12) **United States Design Patent**
O'Neil

(10) **Patent No.:** **US D933,789 S**

(45) **Date of Patent:** **** Oct. 19, 2021**

(54) **FLUID LINE CONNECTION SHELL**

(71) Applicant: **Terrence Jay O'Neil**, Johnson City, TN (US)

(72) Inventor: **Terrence Jay O'Neil**, Johnson City, TN (US)

(73) Assignee: **HD Clean, LLC**, Johnson City, TN (US)

(**) Term: **15 Years**

(21) Appl. No.: **29/714,805**

(22) Filed: **Nov. 26, 2019**

(51) **LOC (13) Cl.** **23-01**

(52) **U.S. Cl.**

USPC **D23/262**; D24/127; D24/129; D23/265

(58) **Field of Classification Search**

USPC 137/551-552; 251/331; D23/213, 233, 285/345, 377, 388, 390, 16, 45, 148.22, 285/148.26, 244, 384, 395, 420; D24/112, 127, 129, 108, 110.6, 113, 130; D13/133, 154-156; 138/109; 604/535

CPC F16L 11/00

See application file for complete search history.

(56) **References Cited**

U.S. PATENT DOCUMENTS

3,059,209 A * 10/1962 Bird H01R 13/6392
439/369

4,340,052 A * 7/1982 Dennehey A61M 39/165
604/317

4,405,312 A * 9/1983 Gross A61L 2/18
604/29
D464,325 S * 10/2002 Peters D13/156
D569,349 S * 5/2008 Preston D13/156
D599,478 S * 9/2009 Bizup D24/128
D624,645 S * 9/2010 Shaffer D24/129
D634,840 S * 3/2011 Lombardi, III D24/129
D663,022 S * 7/2012 Lombardi, III D24/129
D764,661 S * 8/2016 Babbs D24/129
D834,186 S * 11/2018 Lombardi, III D24/129
D844,780 S * 4/2019 White D24/129
2008/0277924 A1 * 11/2008 Jensen F16L 37/0987
285/81

* cited by examiner

Primary Examiner — Amy C Wierenga

(74) *Attorney, Agent, or Firm* — John Wood; Wood Patent Law

(57) **CLAIM**

The ornamental design for a fluid line connection shell, as shown and described.

DESCRIPTION

FIG. 1 is a top front perspective view of the fluid line connection shell showing our new design; FIG. 2 is a left side view thereof; FIG. 3 is a right side view thereof; FIG. 4 is a front view thereof; FIG. 5 is a rear view thereof; FIG. 6 is a top view thereof; and, FIG. 7 is a bottom view thereof.

The broken lines shown represent portions of the fluid line connection shell and form no part of the claimed design.

1 Claim, 5 Drawing Sheets

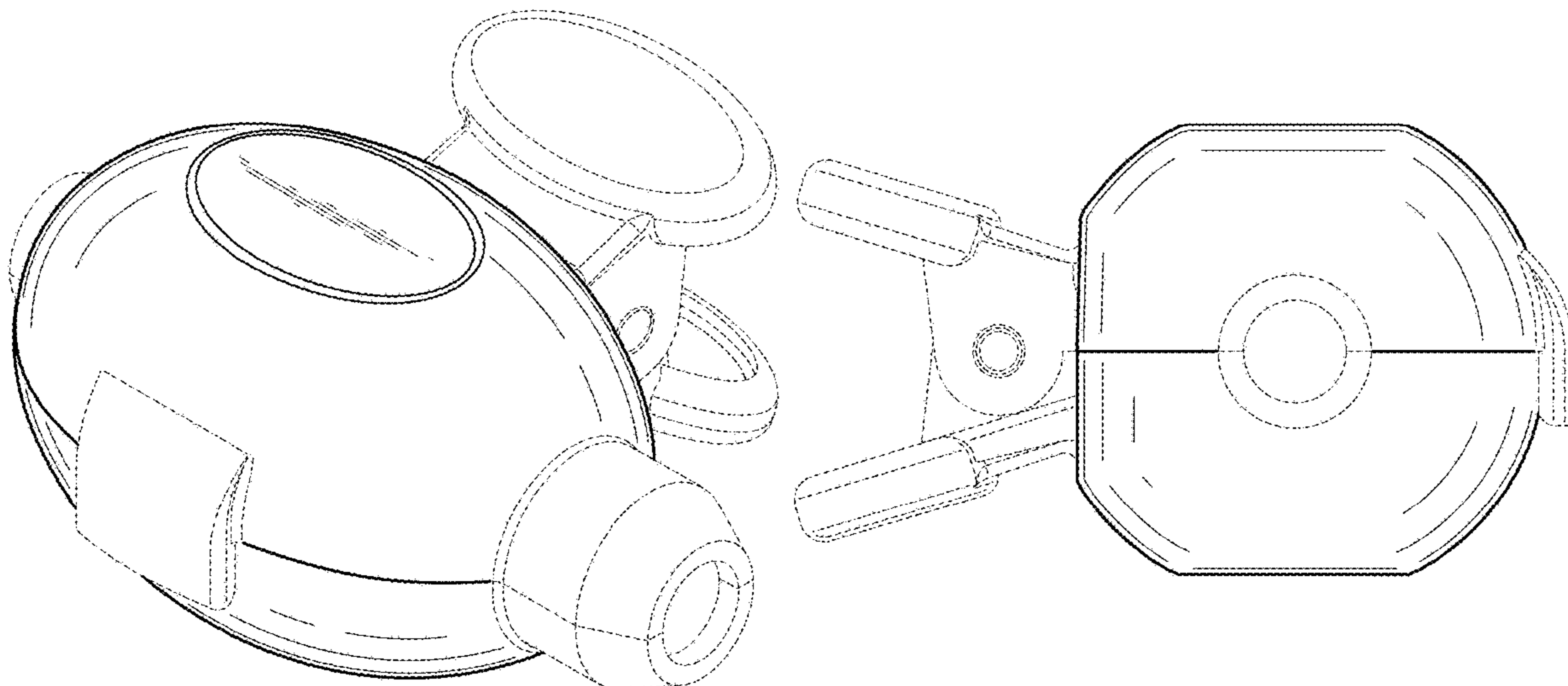

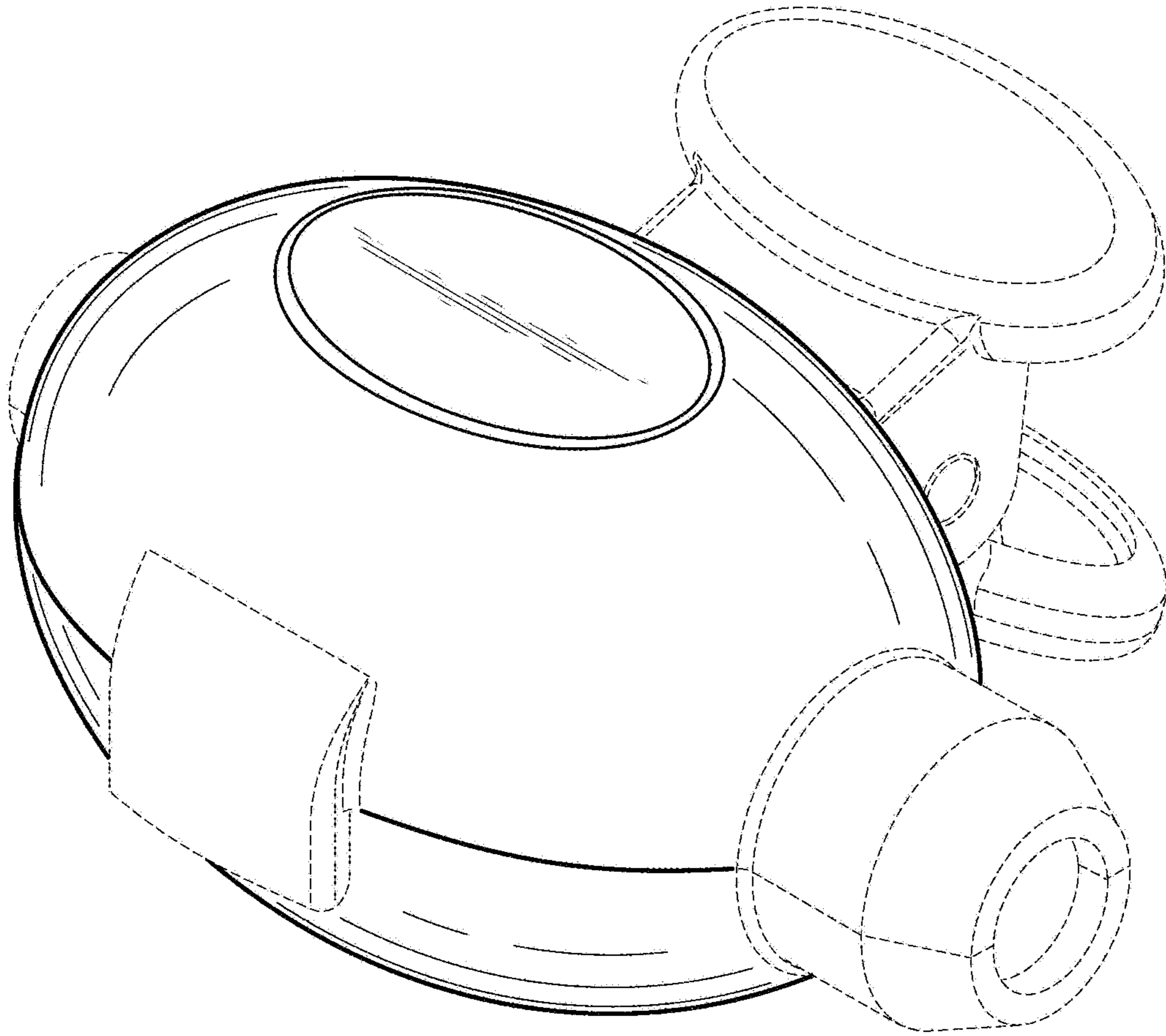

FIG. 1

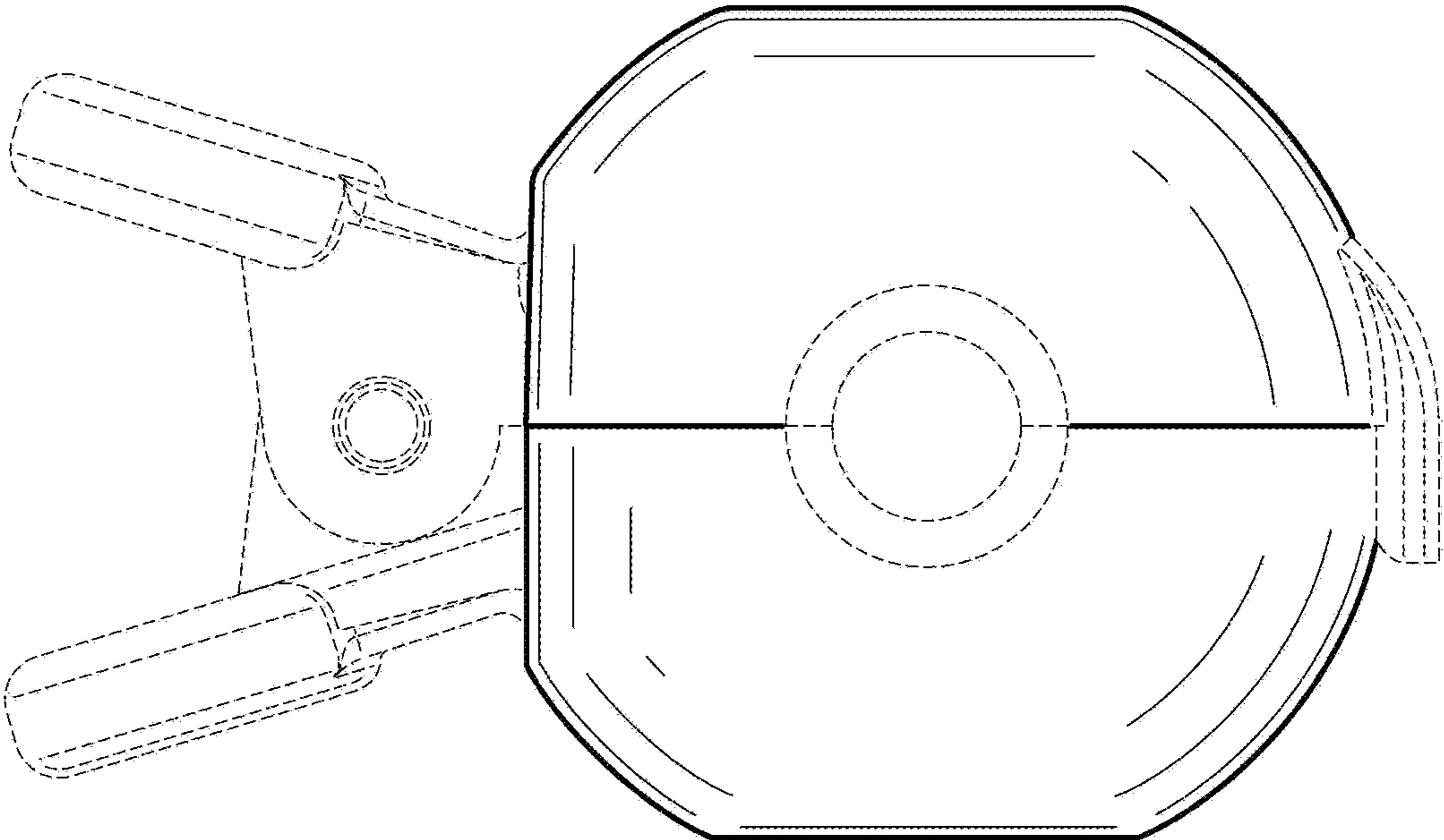

FIG. 2

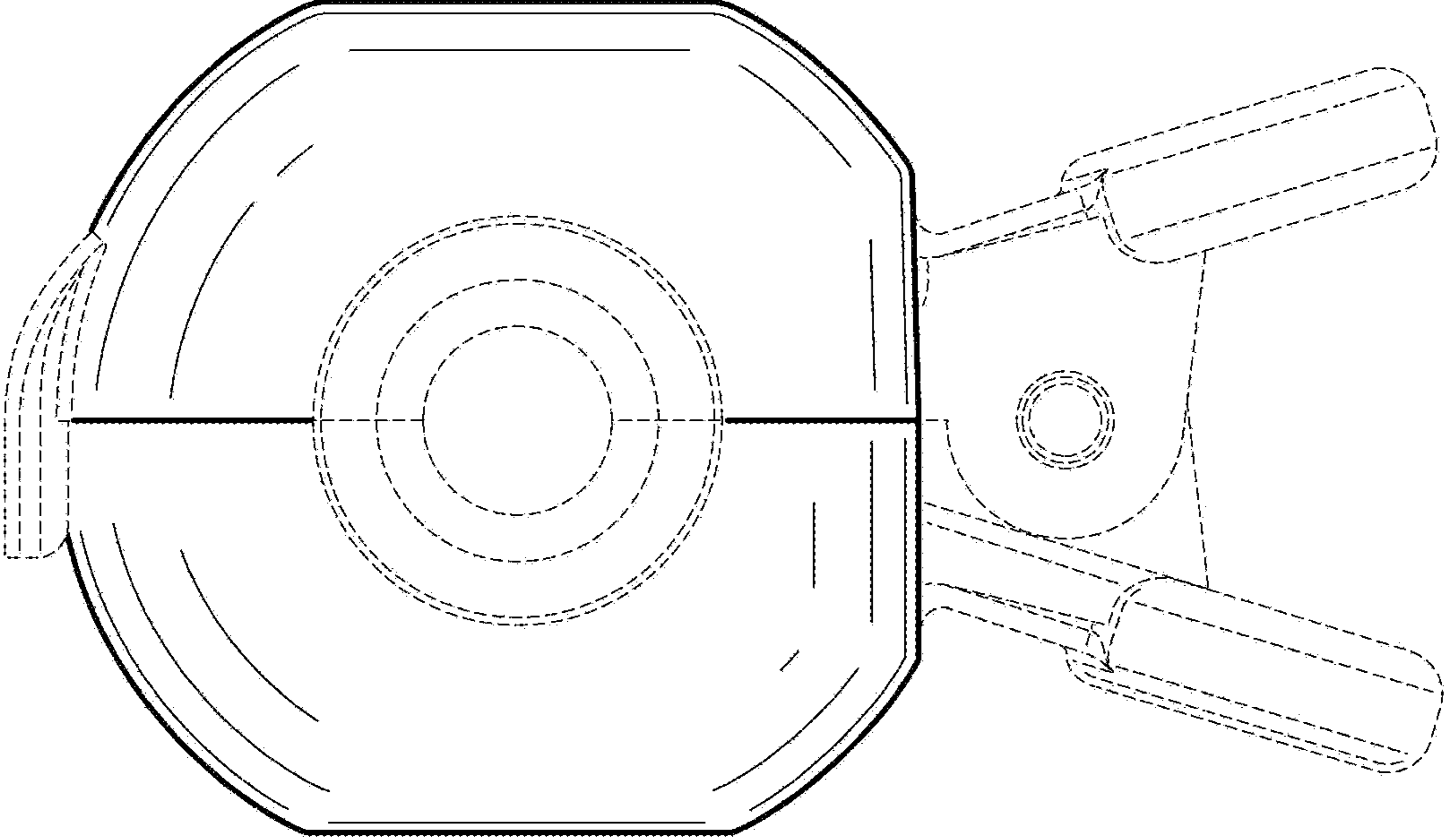

FIG. 3

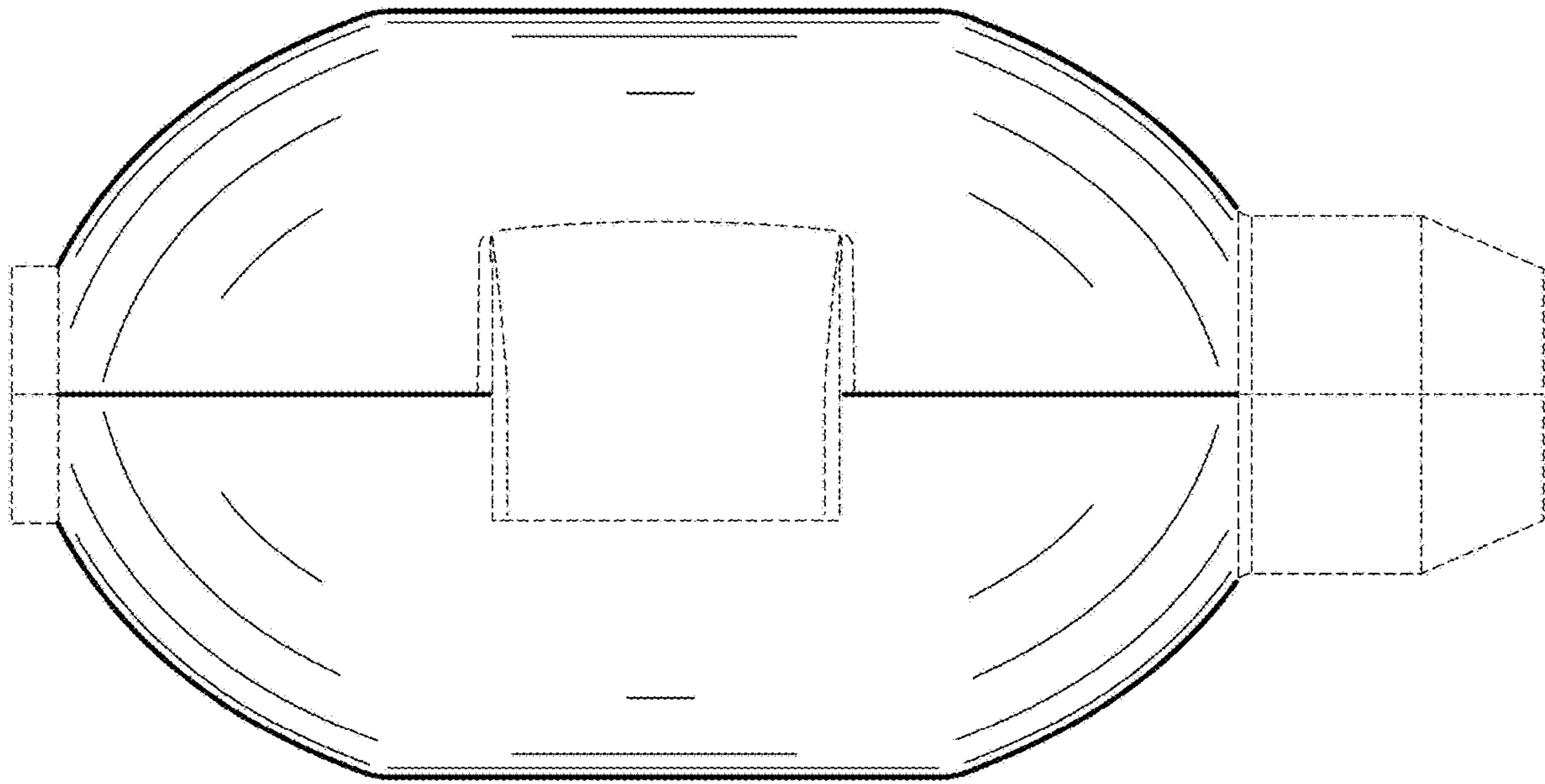

FIG. 4

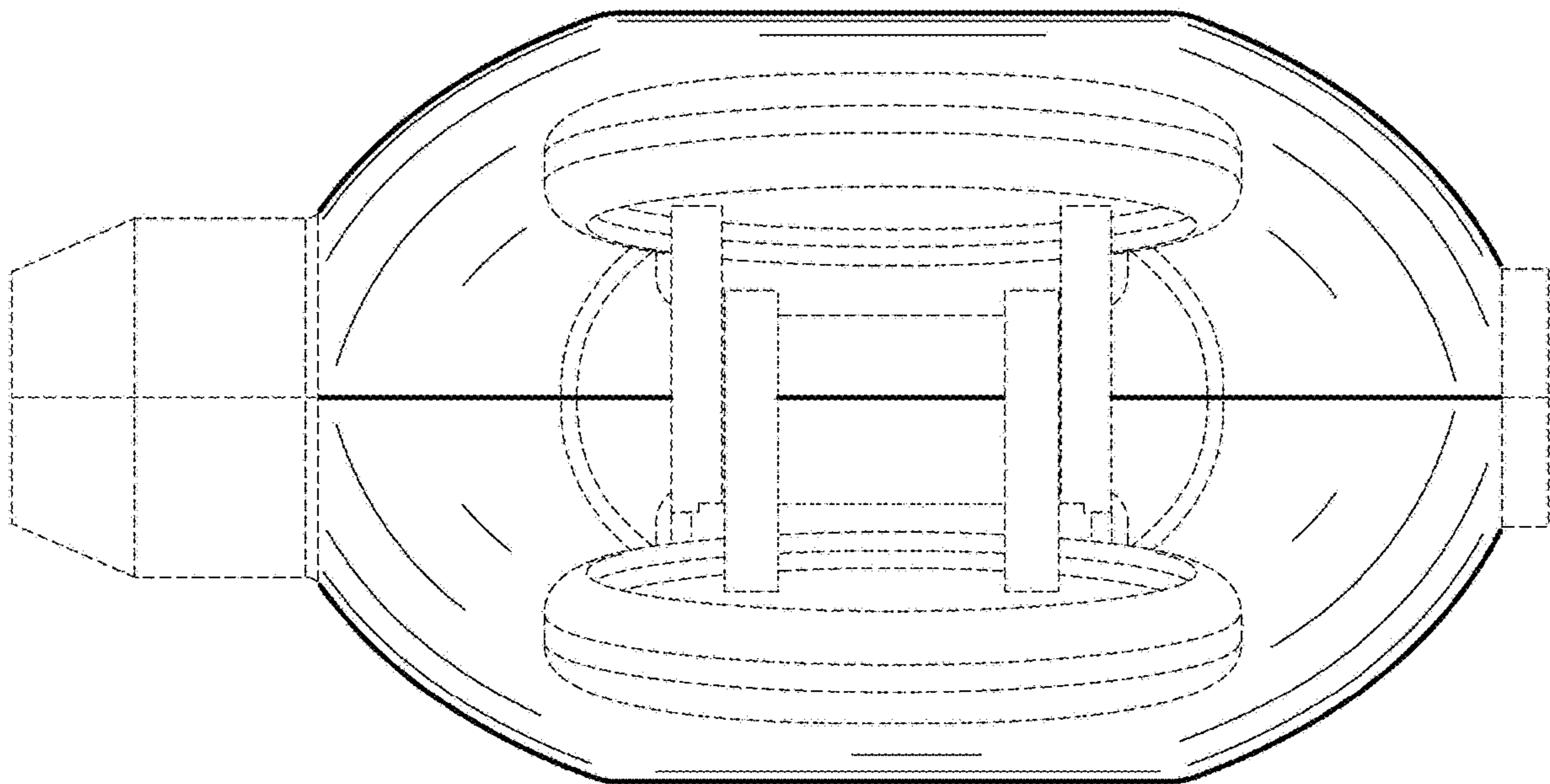

FIG. 5

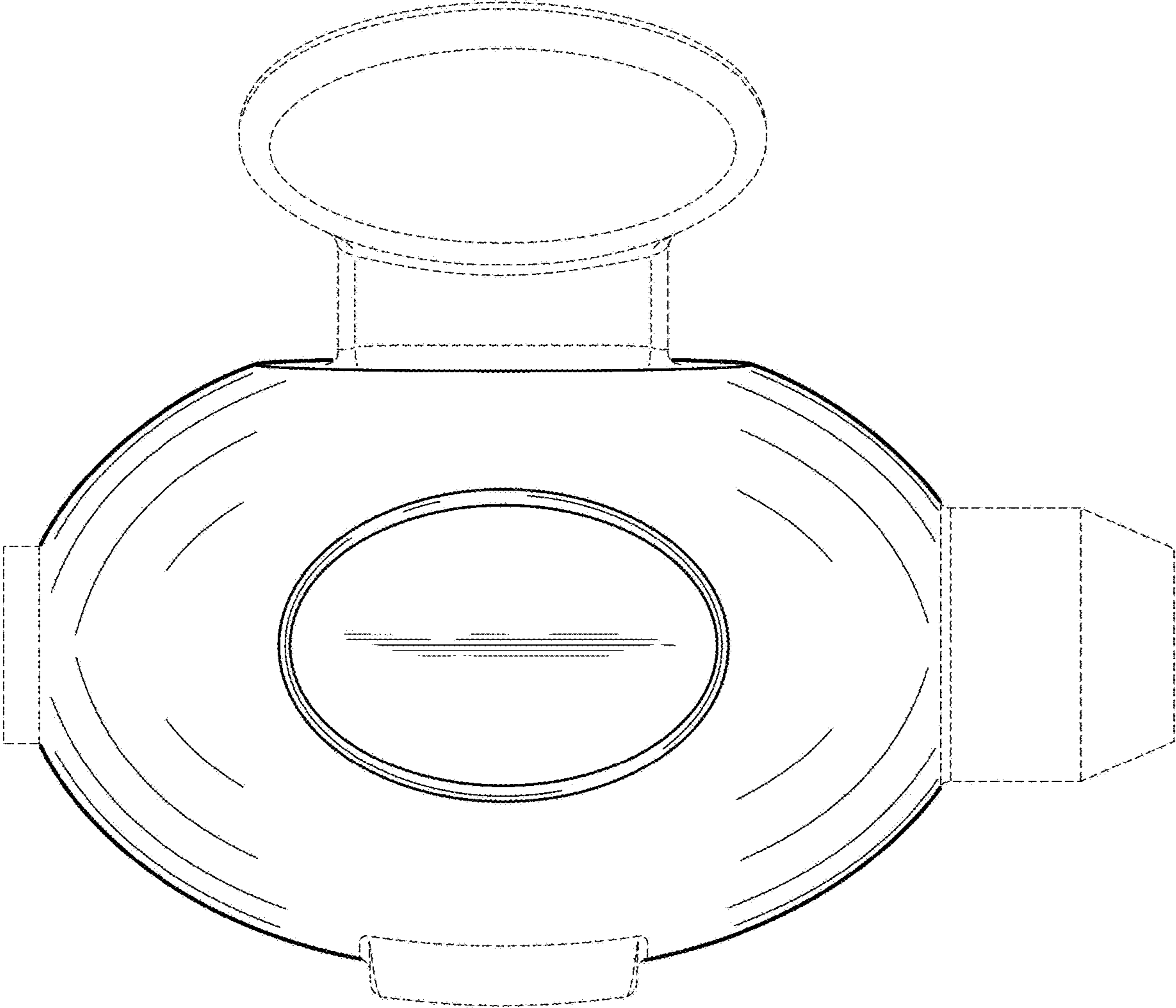

FIG. 6

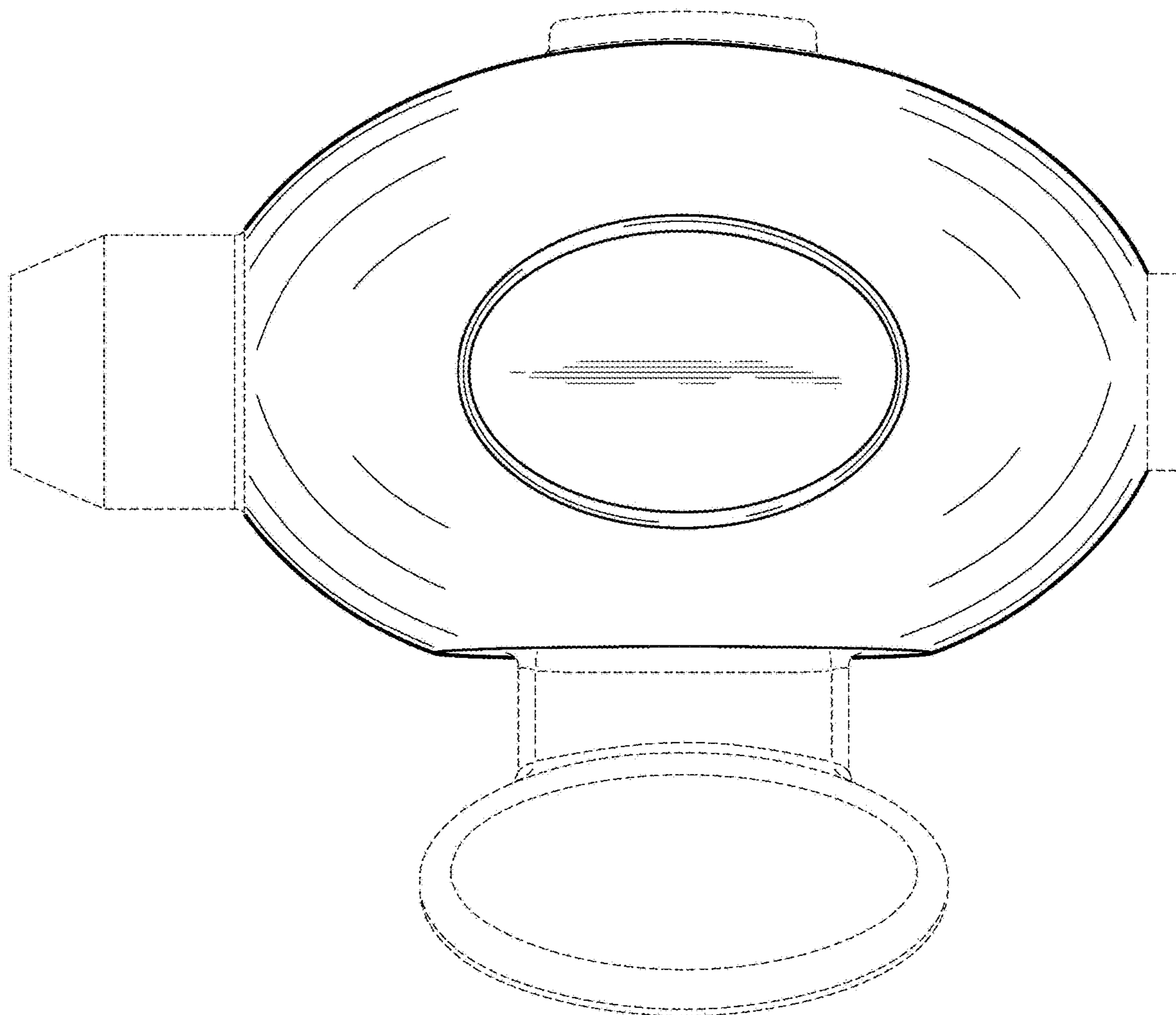

FIG. 7