

US00D933554S

(12) **United States Design Patent**
Jenkins et al.

(10) **Patent No.:** **US D933,554 S**

(45) **Date of Patent:** **** Oct. 19, 2021**

(54) **VEHICULAR STEERING WHEEL**
(71) Applicant: **Atieva Inc.**, Ugland House (KY)

D853,911 S * 7/2019 Miyamoto D12/176
D875,001 S * 2/2020 Moir D12/176
D909,936 S * 2/2021 Nakaura D12/176

(72) Inventors: **Derek N. Jenkins**, Malibu, CA (US);
Joann Jung, Union City, CA (US); **Zeb**
Michael Coughenour, Redwood City,
CA (US)

OTHER PUBLICATIONS

Moore, R., Lucid Motors Air™ prototype vehicle review article,
TopSpeed (published Aug. 25, 2017).
Dow, J., Electrek article, “Lucid shows off their ‘airy’ interior at a
private LA event” (Feb. 13, 2017).
Photo of Audi e-tron steering wheel (published 2019).
Polestar 2s Infotainment system (published Jul. 23, 2020).

(73) Assignee: **Atieva Inc.**, Grand Cayman (KY)

(**) Term: **15 Years**

* cited by examiner

(21) Appl. No.: **29/747,160**

Primary Examiner — Melody N Brown

(22) Filed: **Aug. 20, 2020**

(51) **LOC (13) Cl.** **12-16**

(57) **CLAIM**

(52) **U.S. Cl.**
USPC **D12/176**

The ornamental design for a vehicular steering wheel, as
shown and described.

(58) **Field of Classification Search**
USPC D12/175, 176, 177; 74/552, 558, 558.5
CPC B60R 21/203; B60R 21/05; B62D 1/04
See application file for complete search history.

DESCRIPTION

(56) **References Cited**

U.S. PATENT DOCUMENTS

D516,477 S * 3/2006 Tomasson D12/176
D565,485 S * 4/2008 Schafmeister D12/176
D735,099 S * 7/2015 Ritchie D12/176
D766,147 S * 9/2016 Ritchie D12/176
D778,793 S * 2/2017 Ding D12/176
D786,154 S * 5/2017 Castaman D12/176
D801,894 S * 11/2017 Kasano D12/176
D814,998 S * 4/2018 Lokers D12/176
D814,999 S * 4/2018 Lokers D12/176
D816,567 S * 5/2018 Yoo D12/176

FIG. 1 is a front perspective view of a vehicular steering wheel showing our new design;
FIG. 2 is a front elevational view thereof;
FIG. 3 is a top perspective view thereof;
FIG. 4 is a side elevational view thereof;
FIG. 5 is an opposite side elevational view thereof;
FIG. 6 is a bottom perspective view thereof; and,
FIG. 7 is a rear elevational view thereof.
The broken lines shown representing the “LUCID” text,
front attachment features and tilt adjustment features
throughout the drawing views are for environmental and
illustrative purposes and from no part of the claimed design.

1 Claim, 7 Drawing Sheets

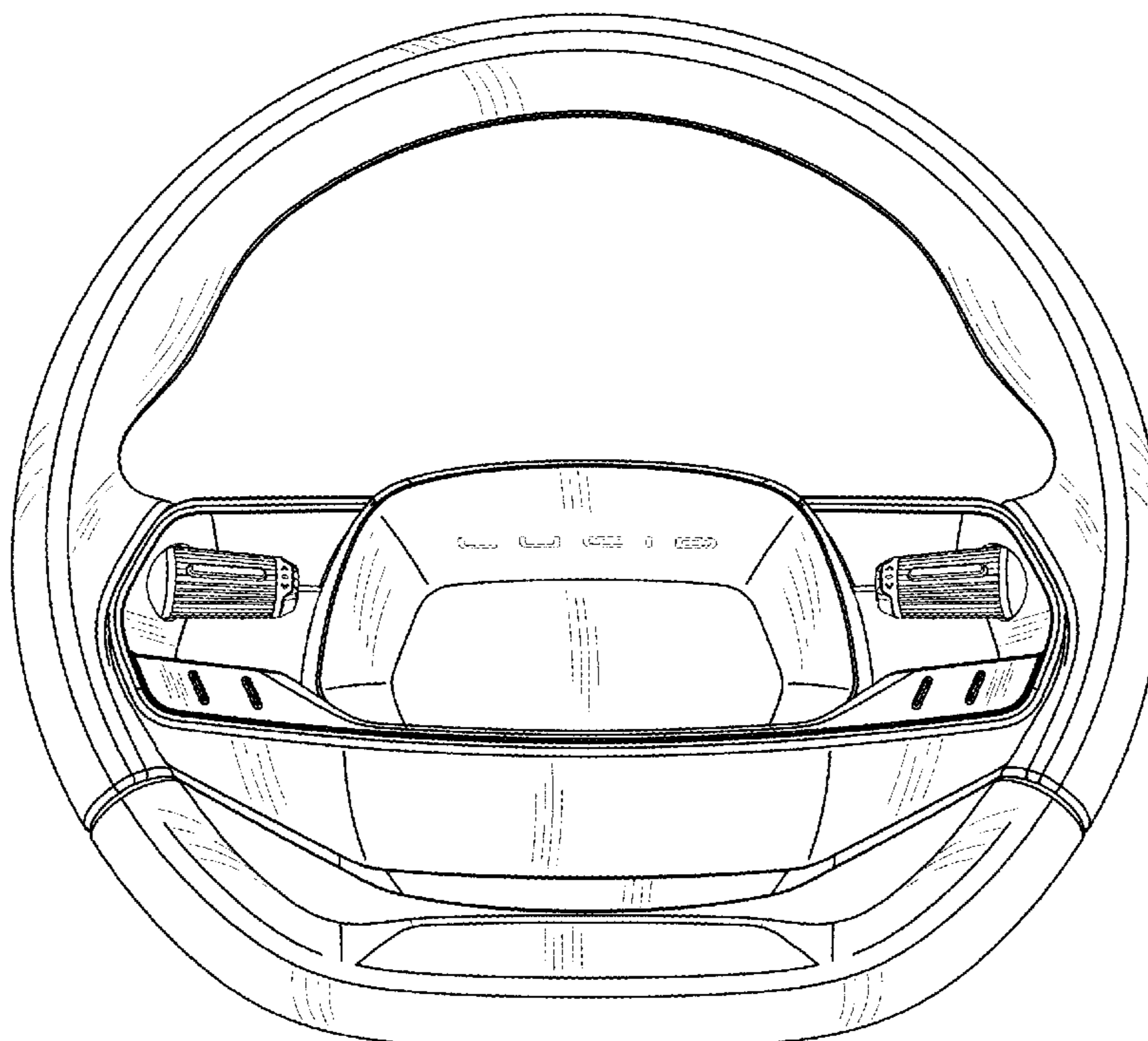

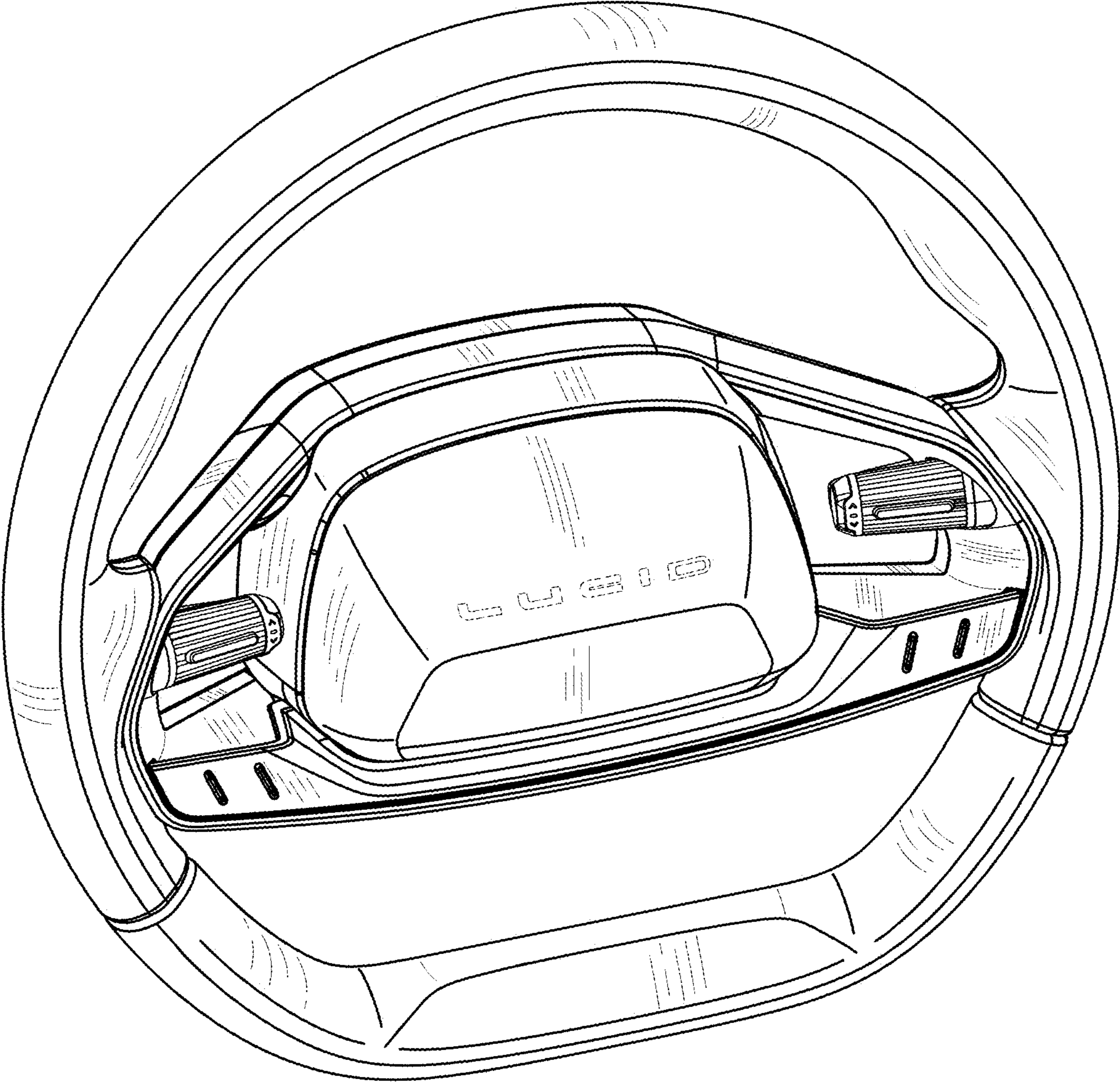

FIG - 1

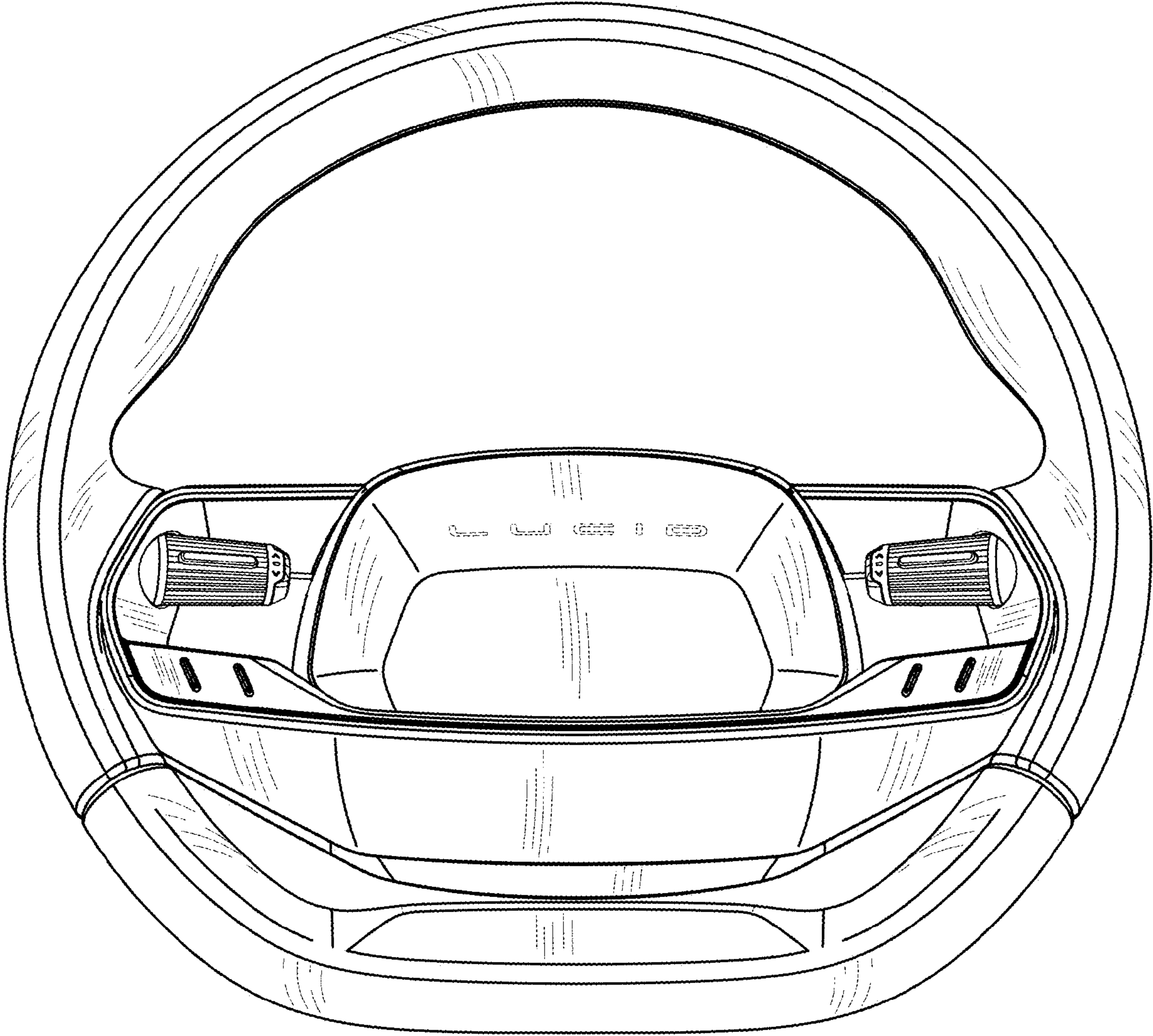

FIG - 2

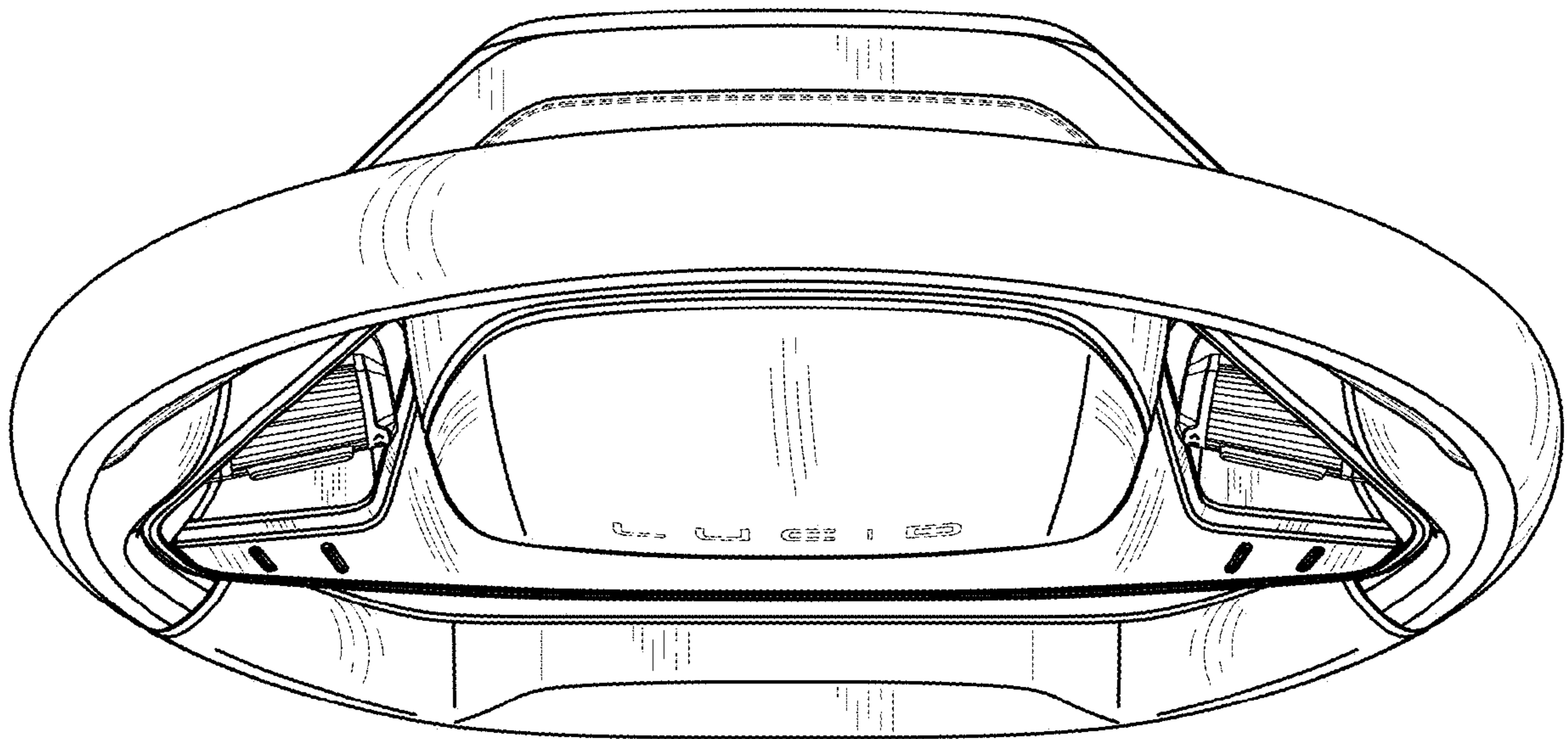

FIG - 3

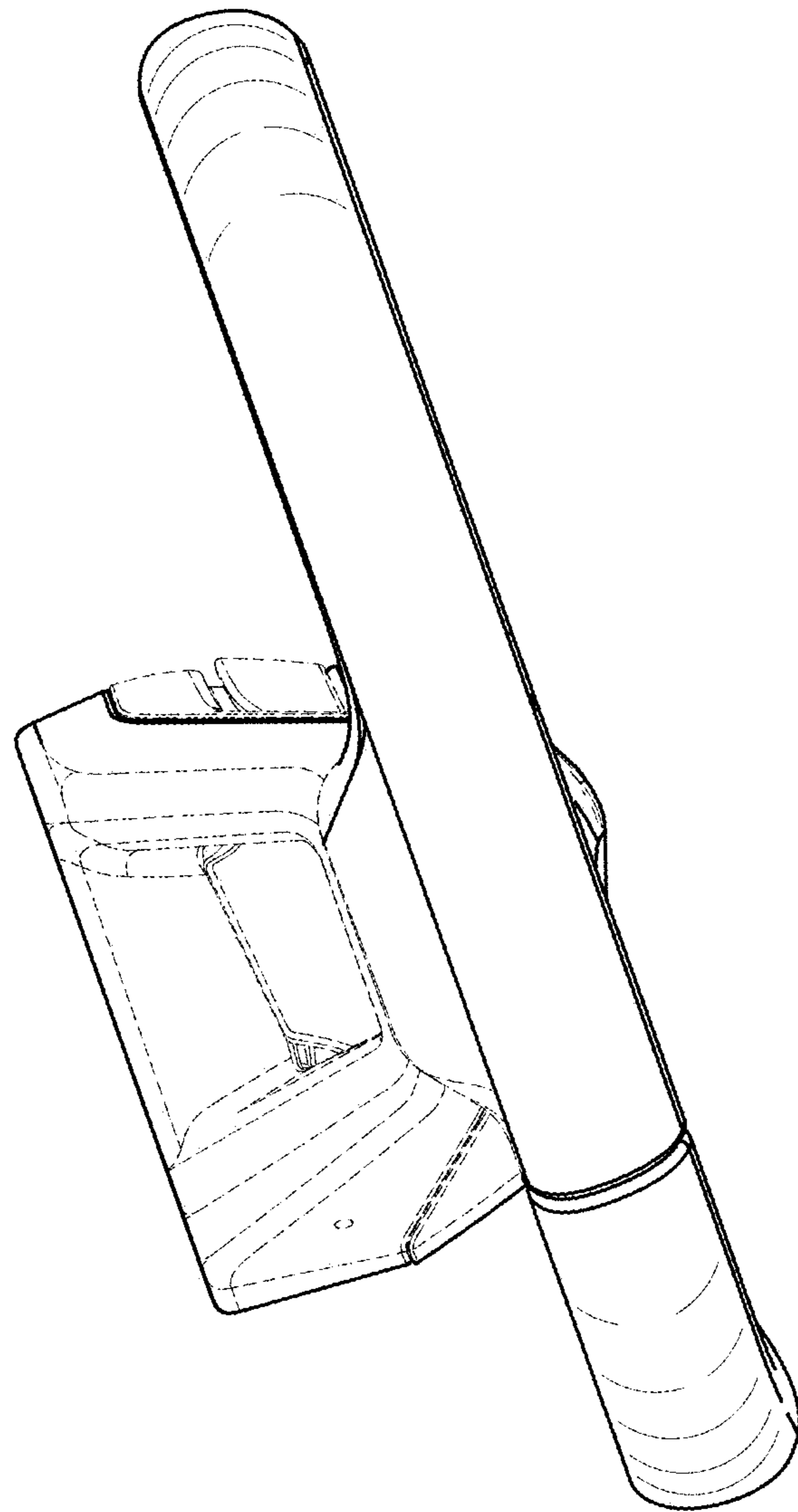

FIG - 4

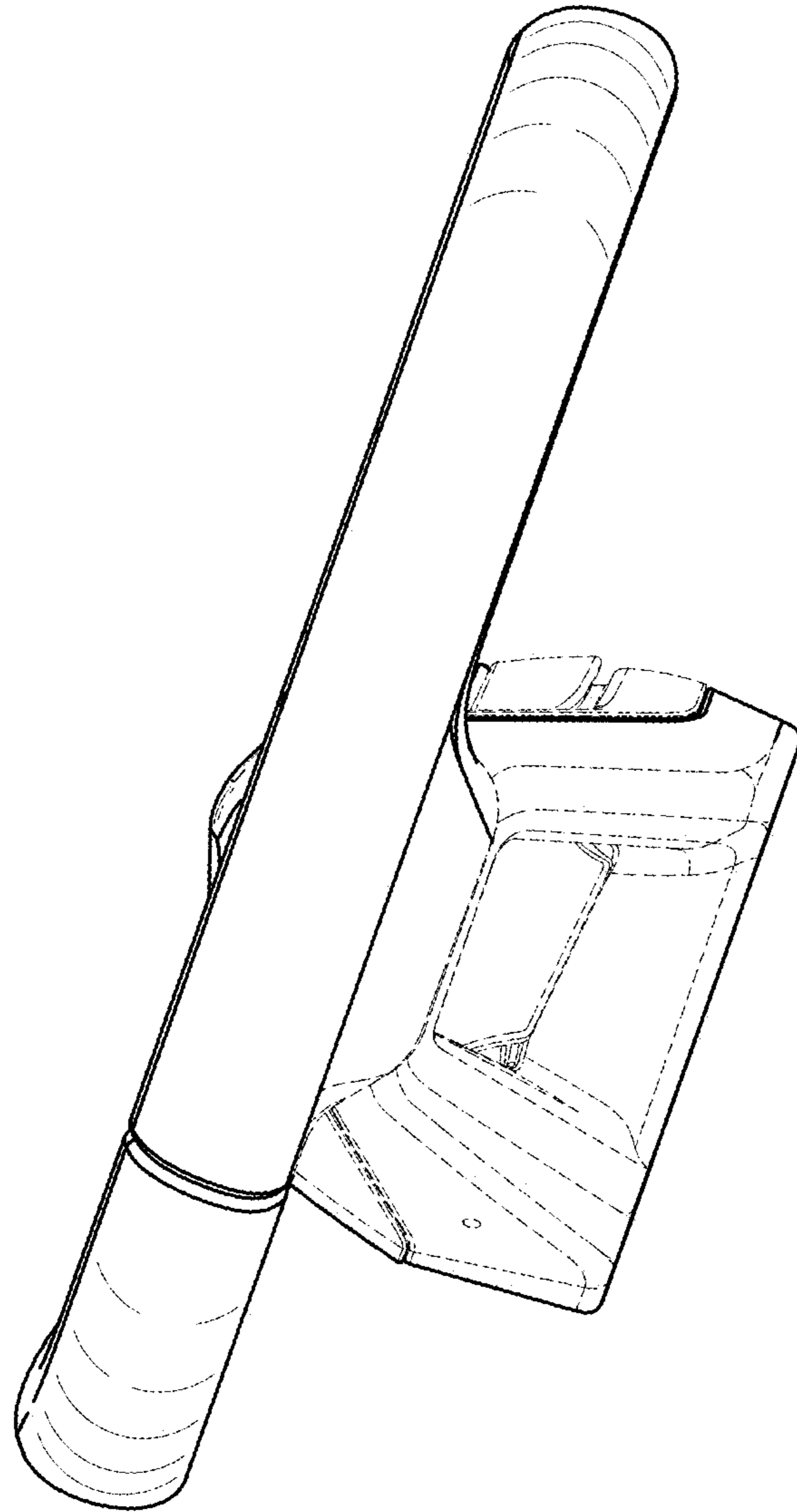

FIG - 5

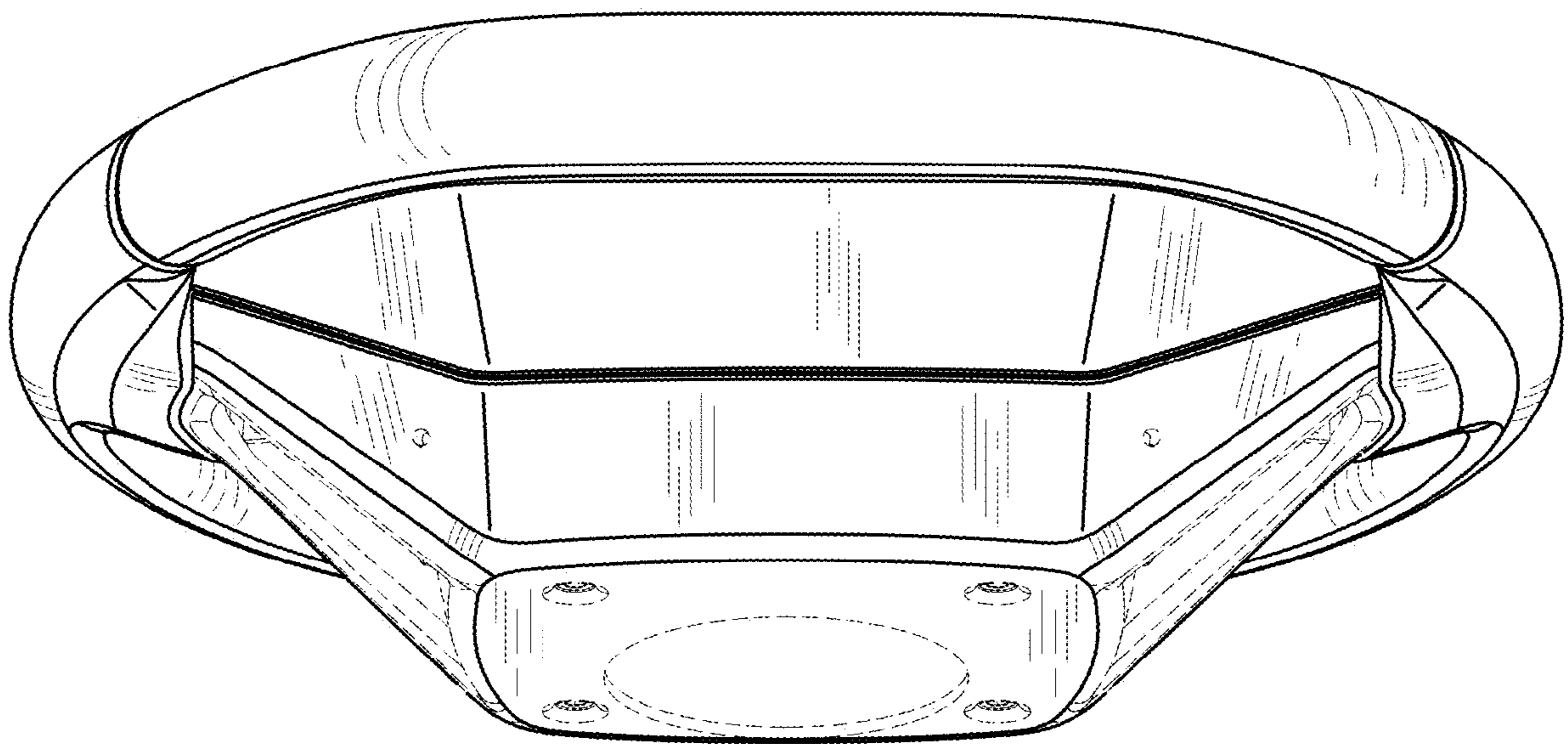

FIG - 6

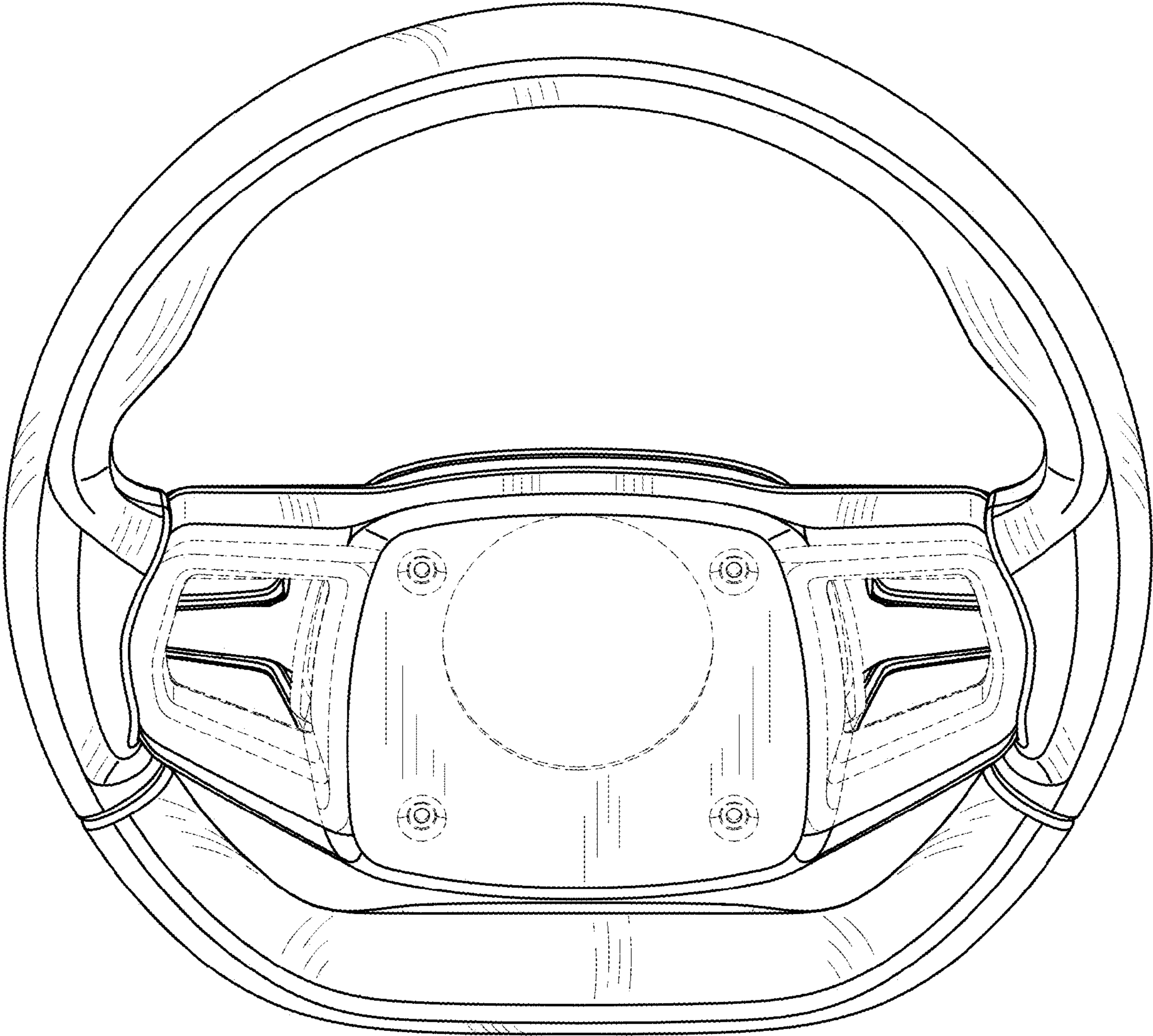

FIG - 7