



US00D933449S

(12) **United States Design Patent** (10) **Patent No.:** **US D933,449 S**
Ahlström et al. (45) **Date of Patent:** **** Oct. 19, 2021**

(54) **LATCH**

(71) Applicant: **Dometic Sweden AB**, Solna (SE)
(72) Inventors: **Joakim Ahlström**, Täby (SE); **Samuele Meda**, Solna (SE)
(73) Assignee: **Dometic Sweden AB**, Solna (SE)
(**) Term: **15 Years**

(21) Appl. No.: **29/585,279**

(22) Filed: **Nov. 22, 2016**

(51) **LOC (13) Cl.** **08-07**

(52) **U.S. Cl.**
USPC **D8/331**

(58) **Field of Classification Search**
USPC D8/331, 330, 333, 339, 343, 344, 345, D8/349, 354, 355, 356, 367, 382; 70/49, 70/58, DIG. 63, DIG. 354, 30, 51, 52, 57, 70/57.1, 141, 431, 465, 466, 29, 63-76, 70/78, DIG. 31, DIG. 26, DIG. 67; 292/288, DIG. 30, 292, 181-287, 292/DIG. 16, DIG. 53, DIG. 42; 24/455, 24/572.1, 573.09, 265 R, 307 R, 458
CPC B65D 81/3816; E05C 19/10; E05C 19/18; E05B 73/00; B25G 3/00; B25G 3/12
See application file for complete search history.

(56) **References Cited**

U.S. PATENT DOCUMENTS

2,734,353 A 2/1956 Hill, II
3,894,405 A 7/1975 Mielitz
4,024,731 A 5/1977 Branscum
4,403,929 A 9/1983 Nagasaku et al.

(Continued)

FOREIGN PATENT DOCUMENTS

AU 201712770 5/2017
AU 201712799 5/2017

(Continued)

OTHER PUBLICATIONS

Transmittal Letter of Related Cases.
(Continued)

Primary Examiner — Manpreet S Matharu

Assistant Examiner — Yolanda Robinson

(74) *Attorney, Agent, or Firm* — Middleton Reutlinger

(57) **CLAIM**

The ornamental design for a latch, as shown and described.

DESCRIPTION

Cross-reference is made to U.S. Design patent application Ser. No. 29/585,272 titled “Cooler,” filed Nov. 22, 2016, and U.S. Utility patent application Ser. No. 15/819,950 titled “Cooler”, filed Nov. 21, 2017, all of which are expressly incorporated herein by reference.

FIG. 1 is a front perspective view of a first embodiment of a latch design;

FIG. 2 is a front elevation view of the design of FIG. 1;

FIG. 3 is a rear elevation view of the design of FIG. 1;

FIG. 4 is a left side elevation view of the design of FIG. 1, the right side elevation being a mirror image of FIG. 4;

FIG. 5 is a top plan view of the design of FIG. 1;

FIG. 6 is a bottom plan view of the design of FIG. 1;

FIG. 7 is a front perspective view of a second embodiment of a latch design;

FIG. 8 is a front elevation view of the design of FIG. 7;

FIG. 9 is a rear elevation view of the design of FIG. 7;

FIG. 10 is a left side elevation view of the design of FIG. 7, the right side elevation being a mirror image of FIG. 10;

FIG. 11 is a top plan view of the design of FIG. 7; and,

FIG. 12 is a bottom plan view of the design of FIG. 7.

The broken lines illustrating portions of the latch form no part of the claimed design.

1 Claim, 12 Drawing Sheets

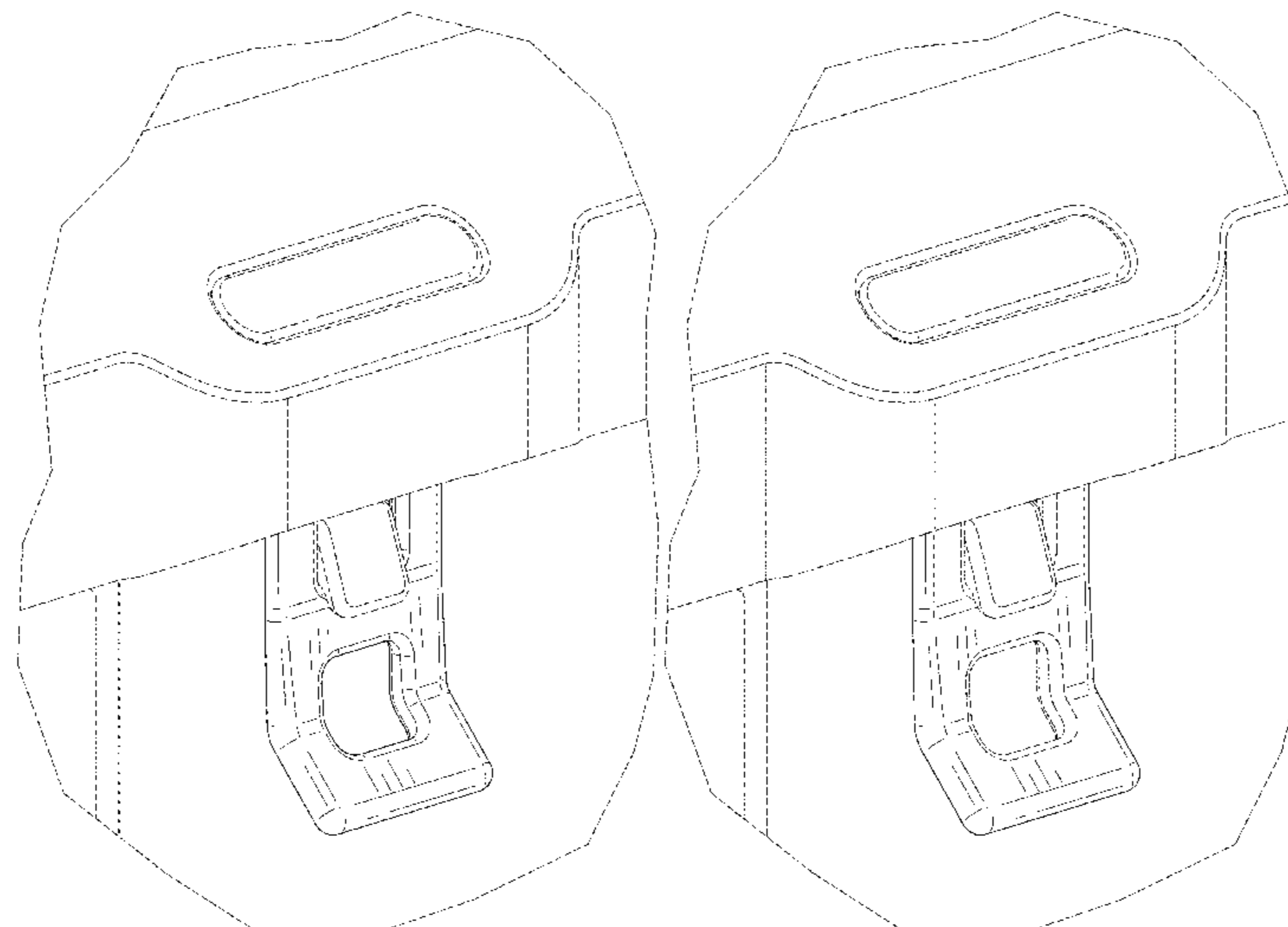

(56)

References Cited

U.S. PATENT DOCUMENTS

D281,695 S 12/1985 Ryan, Jr.
 4,637,222 A 1/1987 Fujiwara et al.
 4,708,598 A 11/1987 Sugita et al.
 4,889,257 A 12/1989 Steffes
 D337,232 S 7/1993 Kahl
 5,226,294 A 7/1993 Mayer
 5,407,218 A 4/1995 Jackson
 D374,772 S 10/1996 Hotaling et al.
 5,676,296 A 10/1997 Masters
 5,738,238 A * 4/1998 Yang B65D 45/24
 16/267
 D400,053 S 10/1998 Coffee et al.
 5,860,281 A 1/1999 Coffee et al.
 D416,447 S 11/1999 Levy et al.
 6,079,599 A 6/2000 Nordstrom et al.
 D429,606 S 8/2000 Israel et al.
 D429,966 S 8/2000 Israel et al.
 D451,765 S 12/2001 Israel et al.
 D454,292 S * 3/2002 Plummer D8/331
 6,474,097 B2 11/2002 Treppedi et al.
 D494,021 S 8/2004 Huthmaker
 D497,517 S 10/2004 Reuter
 D500,057 S 12/2004 Reuter
 6,938,791 B2 9/2005 Robertson et al.
 D512,039 S 11/2005 Kim et al.
 7,082,380 B2 7/2006 Wiebe et al.
 D527,225 S 8/2006 Krieger et al.
 7,140,507 B2 11/2006 Maldonado et al.
 7,143,601 B1 12/2006 Jimenez
 D534,771 S 1/2007 Zorn
 D545,633 S 7/2007 Hussaini et al.
 7,254,956 B2 8/2007 Matonog et al.
 D566,479 S 4/2008 Kabalin
 D566,633 S 4/2008 Kanno et al.
 7,389,608 B1 6/2008 Mackay
 7,392,737 B2 7/2008 Mayorca
 7,415,794 B1 8/2008 Thompson
 D603,664 S 11/2009 Roefs et al.
 7,722,204 B1 5/2010 Sandberg
 7,878,013 B2 2/2011 Matsuno et al.
 7,913,849 B2 3/2011 Pedrazzi et al.
 7,984,997 B1 7/2011 Sandberg
 D642,830 S 8/2011 Buckles et al.
 D646,528 S * 10/2011 Stallman D7/605
 D652,262 S 1/2012 Yang et al.
 8,104,800 B2 1/2012 Lorek
 8,210,702 B1 7/2012 Sandberg
 8,312,816 B2 11/2012 Vaccarella
 8,356,712 B2 1/2013 Piazza, Jr.
 8,511,846 B1 8/2013 Sandberg
 D712,720 S 9/2014 Seiders
 D712,721 S 9/2014 Seiders
 D712,722 S 9/2014 Seiders
 D712,723 S * 9/2014 Seiders B65D 81/3816
 D8/343
 D714,125 S * 9/2014 Seiders B65D 81/3816
 D8/331
 8,910,819 B2 * 12/2014 Seiders B65D 81/3816
 220/326
 8,939,476 B2 * 1/2015 Tang E05C 17/32
 292/251.5
 D722,474 S 2/2015 Seiders
 D722,475 S 2/2015 Seiders
 D732,348 S 6/2015 Seiders et al.
 D732,349 S 6/2015 Seiders et al.
 D732,350 S 6/2015 Seiders et al.
 D732,899 S 6/2015 Seiders et al.
 9,052,131 B2 6/2015 Reimann et al.
 9,139,352 B2 9/2015 Seiders et al.
 9,163,871 B1 10/2015 Costello
 D743,773 S * 11/2015 Shah D8/331
 9,187,232 B2 * 11/2015 Seiders B65D 81/3816
 9,220,250 B1 12/2015 Davis
 D747,950 S * 1/2016 Jacobsen D8/331

D747,951 S * 1/2016 Jacobsen D8/331
 9,232,290 B2 1/2016 Besay
 D748,452 S * 2/2016 Jacobsen D8/331
 D750,953 S * 3/2016 Jacobsen D8/331
 D752,347 S 3/2016 Seiders et al.
 9,297,548 B2 3/2016 Mijanovic et al.
 9,320,938 B1 4/2016 Belmore
 D756,513 S * 5/2016 Cheney D24/133
 D759,590 S * 6/2016 Wang D13/119
 9,366,467 B2 6/2016 Kiedaisch et al.
 D779,306 S * 2/2017 Finkelstein D8/331
 D792,486 S 7/2017 Li et al.
 D802,028 S 11/2017 Li
 D802,029 S 11/2017 Li
 D802,630 S 11/2017 Li et al.
 9,828,137 B2 11/2017 Albert
 9,878,841 B2 1/2018 Holderness et al.
 D820,049 S 6/2018 Ahlström
 D826,027 S * 8/2018 Carey D8/331
 D835,948 S * 12/2018 Jacobsen D7/605
 D836,402 S * 12/2018 Jacobsen D7/605
 D836,993 S 1/2019 Meda et al.
 D836,994 S 1/2019 Meda et al.
 D844,386 S 4/2019 Ahlström et al.
 D844,412 S * 4/2019 Von Holzhausen D8/337
 10,429,116 B2 10/2019 Huish
 D887,788 S 6/2020 Meda et al.
 D888,503 S 6/2020 Meda et al.
 2004/0178208 A1 9/2004 Leba et al.
 2005/0263527 A1 12/2005 Maldonado et al.
 2006/0169691 A1 8/2006 Rothschild
 2007/0193297 A1 8/2007 Wilson
 2009/0139245 A1 * 6/2009 Blackway F25B 21/02
 62/3.62
 2009/0314018 A1 12/2009 Burchill et al.
 2010/0251750 A1 10/2010 Lifson et al.
 2011/0030399 A1 2/2011 Lifson et al.
 2011/0041523 A1 2/2011 Taras et al.
 2011/0162395 A1 7/2011 Chakiachvili et al.
 2011/0226785 A1 9/2011 Sakell
 2012/0011866 A1 1/2012 Scarcella et al.
 2012/0085123 A1 4/2012 Wasnievski da Silva et al.
 2012/0132657 A1 * 5/2012 Seiders B65D 81/3816
 220/592.2
 2012/0198866 A1 8/2012 Zeidner
 2012/0318006 A1 12/2012 Liu et al.
 2012/0318014 A1 12/2012 Huff et al.
 2013/0062356 A1 3/2013 Deka
 2014/0013789 A1 1/2014 Conrad et al.
 2014/0191544 A1 7/2014 Comber
 2014/0314607 A1 10/2014 Maeyama et al.
 2014/0338390 A1 11/2014 Pinto et al.
 2015/0000318 A1 1/2015 Pinto et al.
 2015/0008242 A1 1/2015 Kpabar
 2015/0021106 A1 1/2015 LaRosa
 2015/0114024 A1 4/2015 Grepper
 2015/0122827 A1 5/2015 Smith
 2015/0241107 A1 8/2015 Mech
 2015/0322698 A1 * 11/2015 Seiders B65D 81/3816
 220/592.2
 2015/0353263 A1 12/2015 Seiders et al.
 2015/0357755 A1 * 12/2015 Hastings H01R 12/7005
 439/350
 2015/0375918 A1 12/2015 Holderness et al.
 2016/0046418 A1 * 2/2016 Crull B65D 25/28
 220/318
 2016/0101924 A1 4/2016 Mitchell et al.
 2016/0272047 A1 9/2016 Gan
 2017/0023290 A1 1/2017 DeMuth et al.
 2017/0305638 A1 10/2017 Sonntag et al.
 2018/0141718 A1 5/2018 Ahlström
 2018/0273258 A1 9/2018 Luburic
 2019/0161240 A1 5/2019 Ahlström et al.

FOREIGN PATENT DOCUMENTS

AU 201712802 5/2017
 AU 201712803 5/2017

(56)

References Cited

FOREIGN PATENT DOCUMENTS

AU	201712785	S	7/2017
AU	201712791	S	11/2017
AU	201716791	S	11/2017
CA	1 249 731	A1	2/1989
CN	1240728	A	1/2000
CN	1498311	A	5/2004
CN	1629478	A	6/2005
CN	200985884	Y	12/2007
CN	101431913	A	5/2009
CN	102257278	A	11/2011
CN	102261334	A	11/2011
CN	202066275	U	12/2011
CN	103237990	A	8/2013
CN	103471438	A	12/2013
CN	103542661	A	1/2014
CN	103963600	A	8/2014
CN	104583692	A	4/2015
CN	104697279	A	6/2015
CN	106062367	A	10/2016
CN	106068433	A	11/2016
CN	304400680	S	12/2017
DE	30 02 260	A1	7/1981
DE	41 42 534	A1	7/1992
EM	004006476-0001		5/2017
EM	004006476-0002		5/2017
EM	004006476-0003		5/2017
EM	004007706-0001		5/2017
EM	004007706-0002		5/2017
EP	0 958 952	A1	11/1999
EP	1 867 504	A2	12/2007
JP	H08-247601	A	9/1996
SG	194217	A1	11/2013
TH	66500	S	11/2018
WO	2006/009537	A1	1/2006
WO	2010/131061	A1	11/2010
WO	2018095957	A1	5/2018

OTHER PUBLICATIONS

Dometic CF Portable Coolers, Dometic Product Catalog 2016.
Dometic RV Refrigeration, Portable Freezers/Refrigerators, Dometic Product Catalog 2015.
Chinese Design Patent Application No. 201730180150 entitled "Latch" filed May 16, 2017.
Chinese Design Patent Application No. 201730180148.2 entitled "Refrigerating Apparatus" filed May 16, 2017.
European Design Patent Application No. 003482694 entitled "Cooler" filed Nov. 25, 2016.
Thailand Design Patent Application No. 1702001859 entitled "Cooler" filed May 22, 2017.
Design U.S. Appl. No. 29/585,272, entitled "Cooler" filed Nov. 22, 2016.
Design U.S. Appl. No. 29/604,424, entitled Cooler filed May 17, 2017.
Design U.S. Appl. No. 29/604,426, entitled Cooler filed May 17, 2017.
Design U.S. Appl. No. 29/605,186, entitled Refrigerating Apparatus filed May 24, 2017.
Australian Patent Application No. AU201716789 filed Nov. 8, 2017.
Australian Patent Application No. AU201716791 filed Nov. 8, 2017.
European Design Patent Application No. 003847557-0001 entitled "Smart Cooler" filed Apr. 7, 2017.
European Design Patent Application No. 003847557-0002 entitled "Smart Cooler" filed Apr. 7, 2017.
European Design Patent Application No. 003847557-0003 entitled "Smart Cooler" filed Apr. 7, 2017.

European Design Patent Application No. 003847557-0004 entitled "Smart Cooler" filed Apr. 7, 2017.
European Design Patent Application No. 003847557-0005 entitled "Smart Cooler" filed Apr. 7, 2017.
European Patent Office, International Search Report and Written Opinion for PCT/EP2017/080018 dated Jan. 25, 2018.
International Preliminary Report on Patentability for PCT/EP2017/080018 dated May 28, 2019.
Likchinlow "Igloo Announces Cooler with LiddUp LED Lighting System," Retrieved from Internet URL: https://www.ledinside.com/products/2015/1/igloo_announces_cooler_with_liddup_led_lighting_system, published on Jan. 12, 2015, pp. 3.
"IGLOO Coolers," retrieved from Internet URL: <https://web.archive.org/web/20161026143451/https://www.igloocoolers.com/igloo-life/campaigns-party-on>, retrieved on Jun. 13, 2019, pp. 6.
"Liddup Coolers," retrieved from Internet URL: <https://web.archive.org/web/20161118120853/http://liddup.com/about.html>, retrieved on Jun. 13, 2019, pp. 5.
Australian Patent Application No. 2017365438 filed May 6, 2019 entitled "Cooler".
China Patent Application No. 201780072126.1 filed May 22, 2019 entitled "Cooler".
European Design Patent Application No. 003476415-0001 entitled "" filed Nov. 22, 2016.
European Design Patent Application No. 003476415-0002 entitled "" filed Nov. 22, 2016.
European Design Patent Application No. 003476415-0003 entitled "" filed Nov. 22, 2016.
European Design Patent Application No. 003476415-0004 entitled "" filed Nov. 22, 2016.
European Design Patent Application No. 003476415-0005 entitled "" filed Nov. 22, 2016.
European Design Patent Application No. 003476415-0006 entitled "" filed Nov. 22, 2016.
European Design Patent Application No. 003476415-0007 entitled "" filed Nov. 22, 2016.
Non-Final Rejection Mailed in U.S. Appl. No. 15/819,950 dated Oct. 1, 2019.
Non-Final Rejection Mailed in U.S. Appl. No. 16/264,057 dated Oct. 3, 2019.
United States Design U.S. Appl. No. 29/670,885 entitled "Cooler" filed Nov. 20, 2018.
United States Design U.S. Appl. No. 29/670,888 entitled "Cooler" filed Nov. 20, 2018.
United States Design U.S. Appl. No. 29/708,155 entitled "Latch" filed Oct. 3, 2019.
United States Design U.S. Appl. No. 29/708,156 entitled "Latch" filed Oct. 3, 2019.
U.S. Appl. No. 62/425,288 entitled "Cooler" filed on Nov. 22, 2016.
Notice of Allowance received in US Design U.S. Appl. No. 29/670,888 dated Feb. 19, 2020.
Notice of Allowance received in US Design U.S. Appl. No. 29/670,885 dated Feb. 27, 2020.
Notice of Allowance received in U.S. Appl. No. 29/670,885 dated May 26, 2020.
Notice of Allowance received in U.S. Appl. No. 29/670,888 dated May 26, 2020.
Office Action received in China Patent Application No. 201780072126.1 dated Oct. 19, 2020.
United States Patent and Trademark Office, Final Office Action dated Jul. 16, 2020 in U.S. Appl. No. 15/819,950.
Final Rejection Mailed in U.S. Appl. No. 16/264,057 dated Jul. 20, 2020.
Rejection Decision Issued in China Patent Application No. 201780072126.1 dated Jun. 3, 2021.
United States Patent Office, Office Action for U.S. Appl. No. 16/264,057 dated Aug. 30, 2021.

* cited by examiner

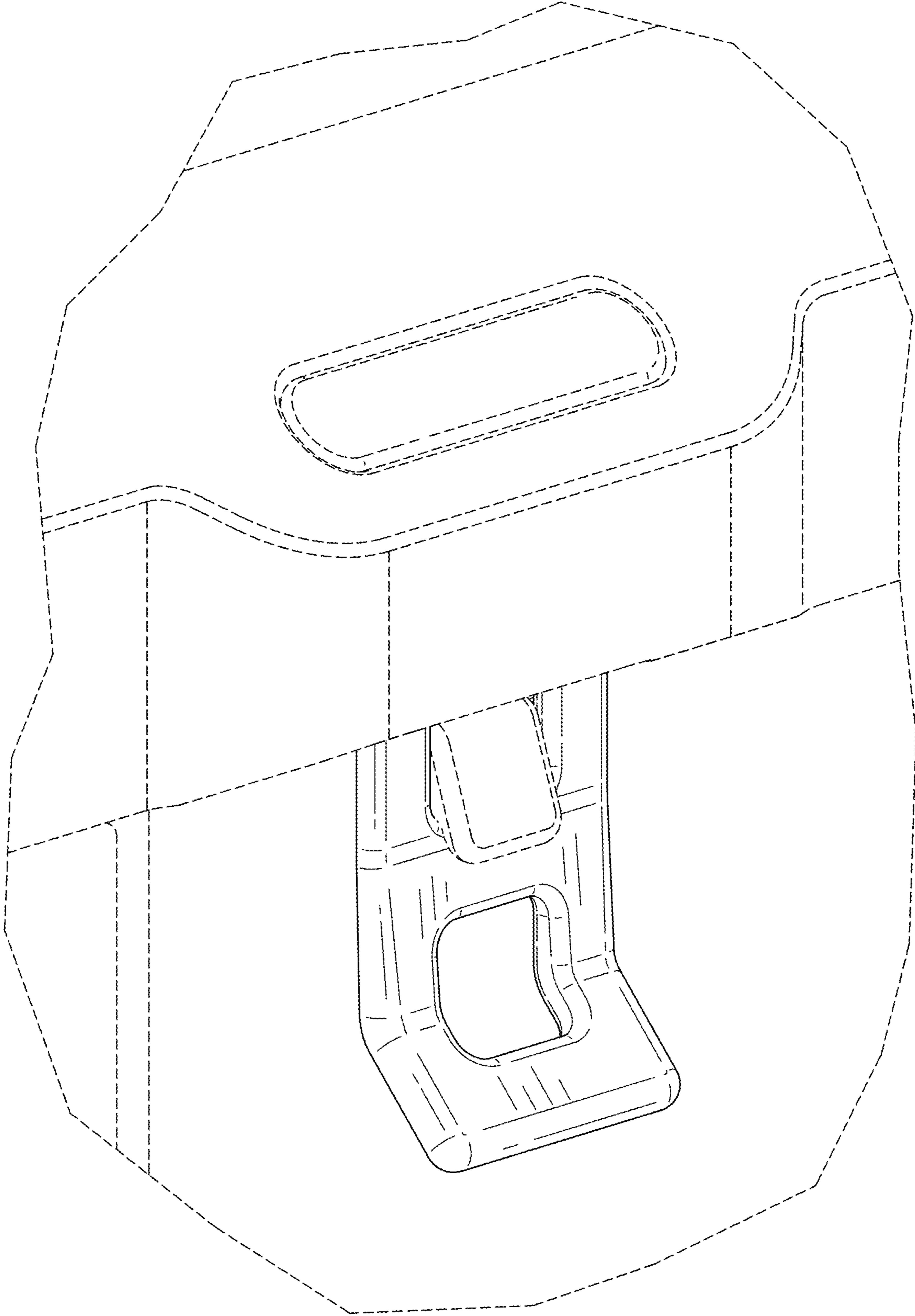

FIG. 1

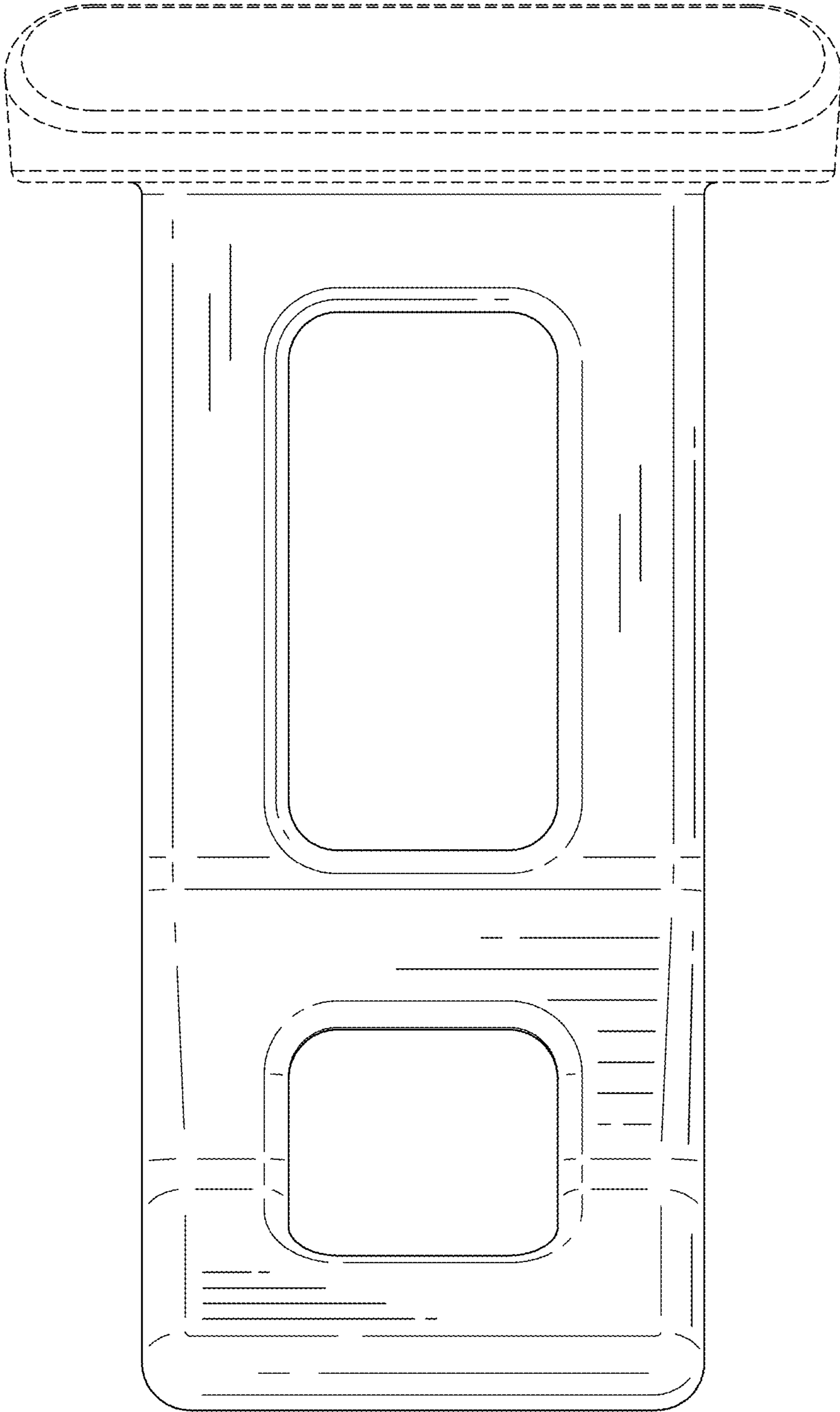

FIG. 2

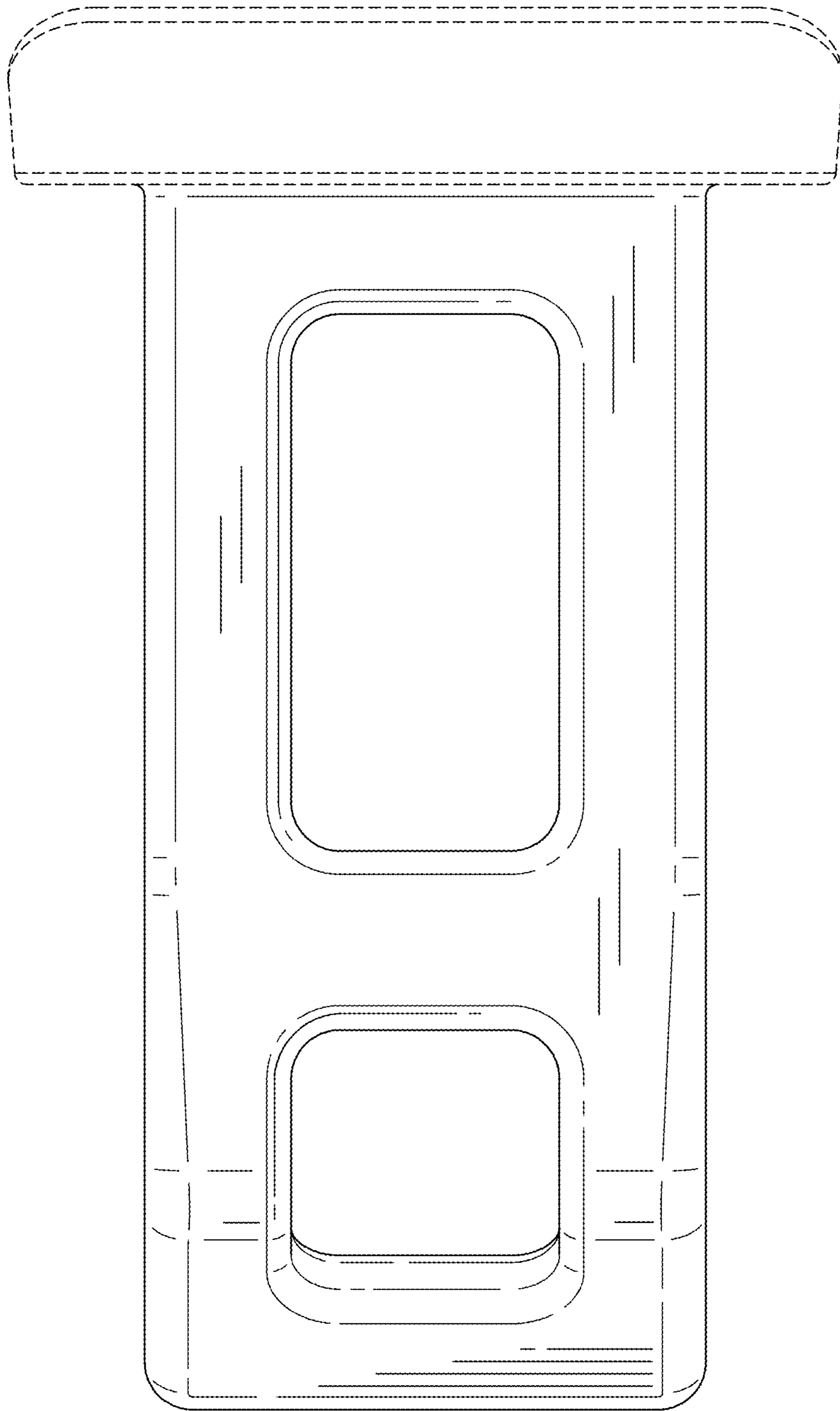

FIG. 3

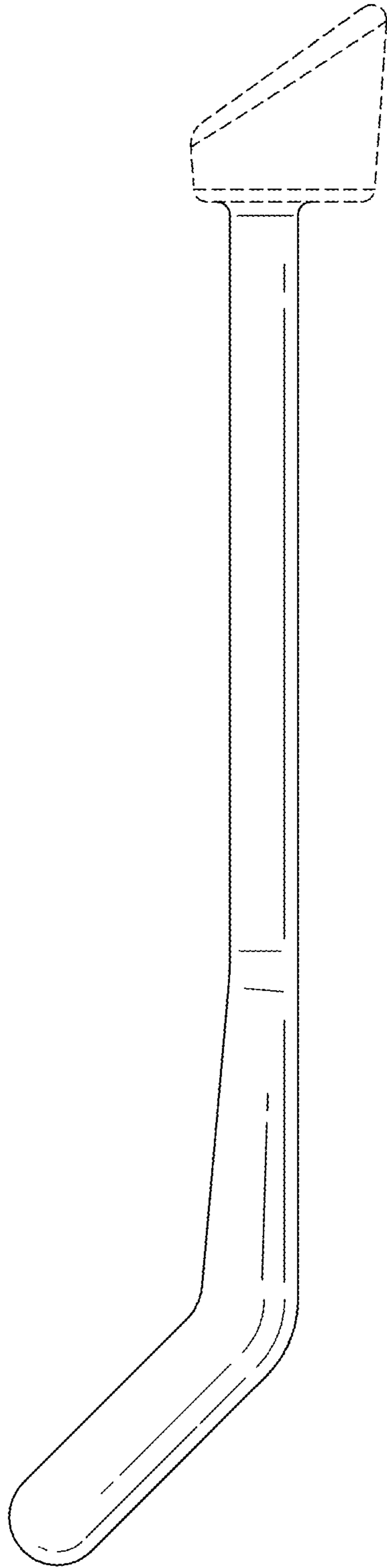

FIG. 4

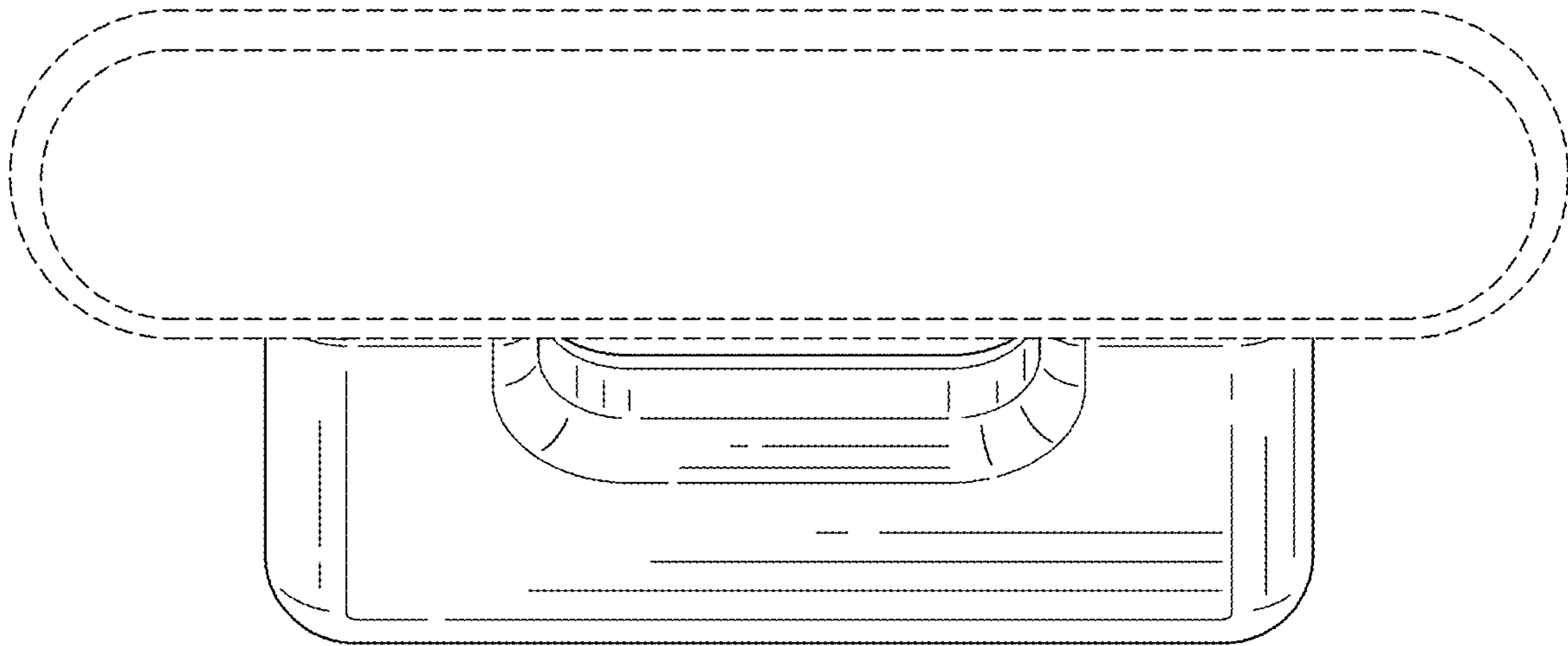

FIG. 5

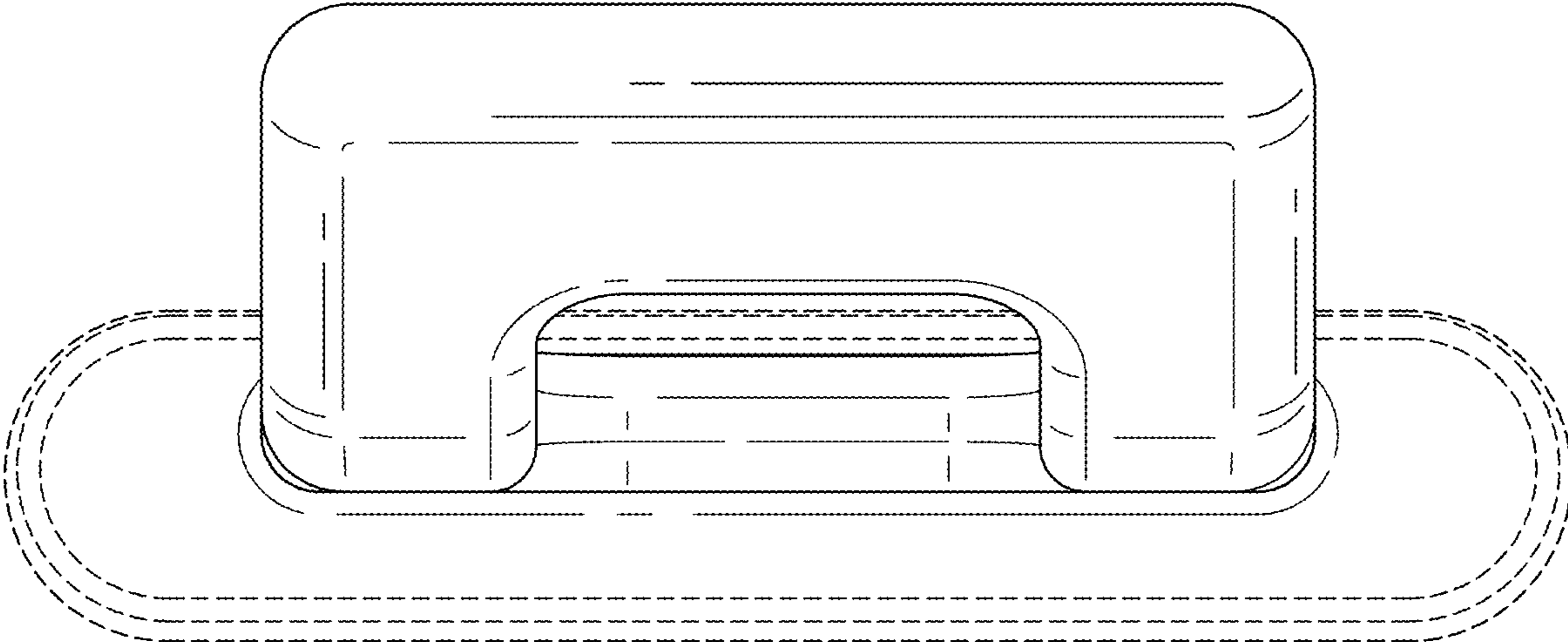

FIG. 6

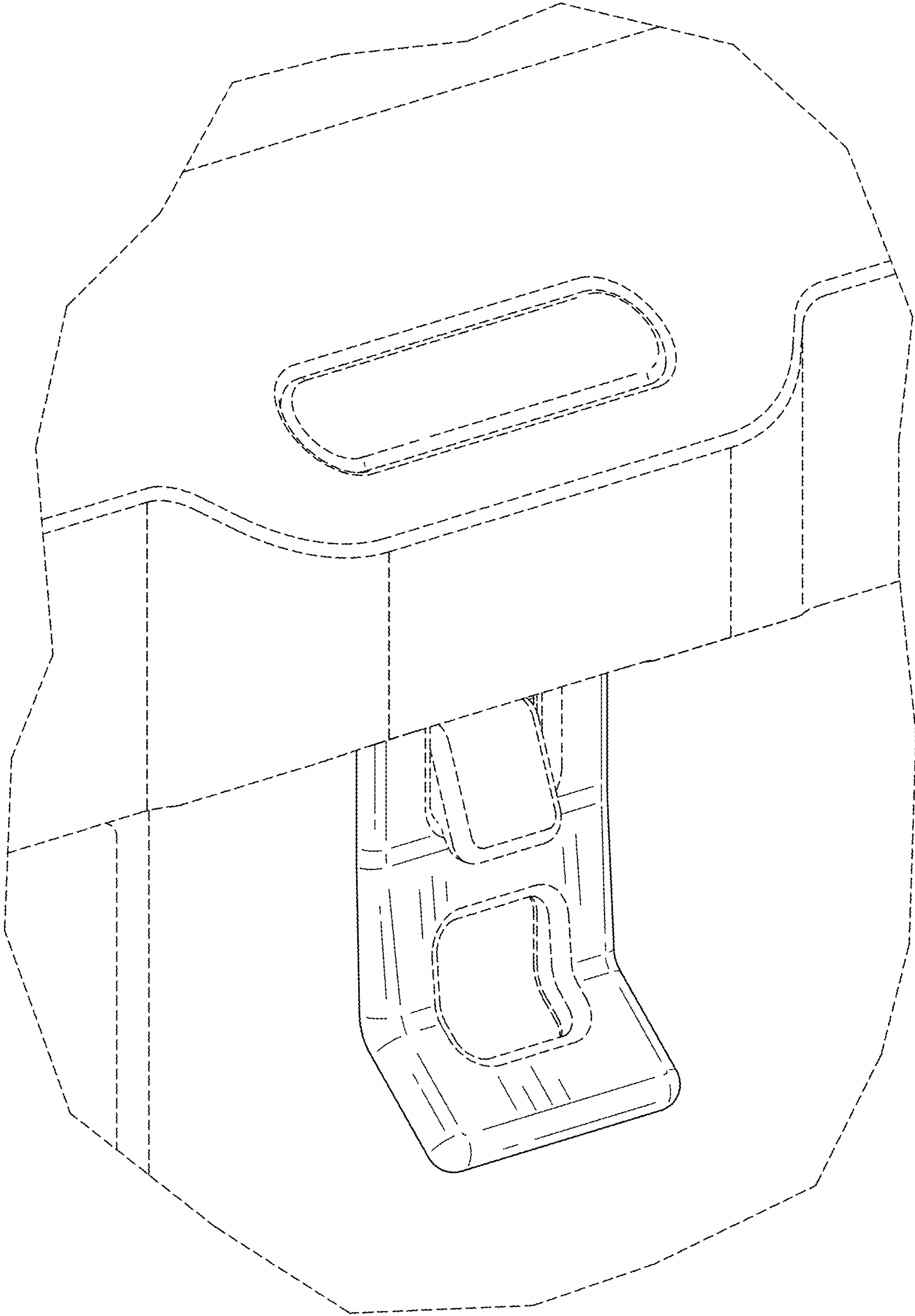

FIG. 7

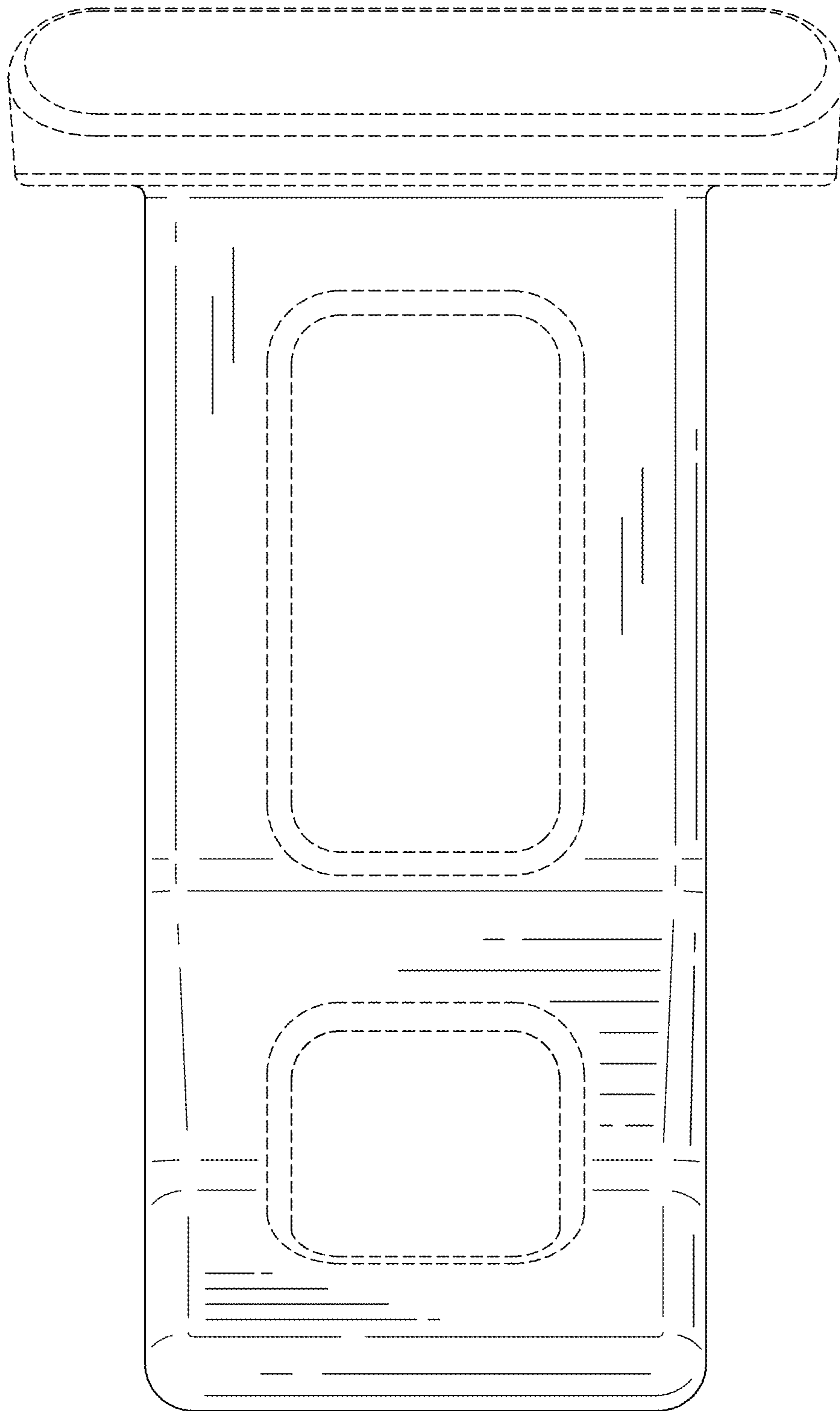

FIG. 8

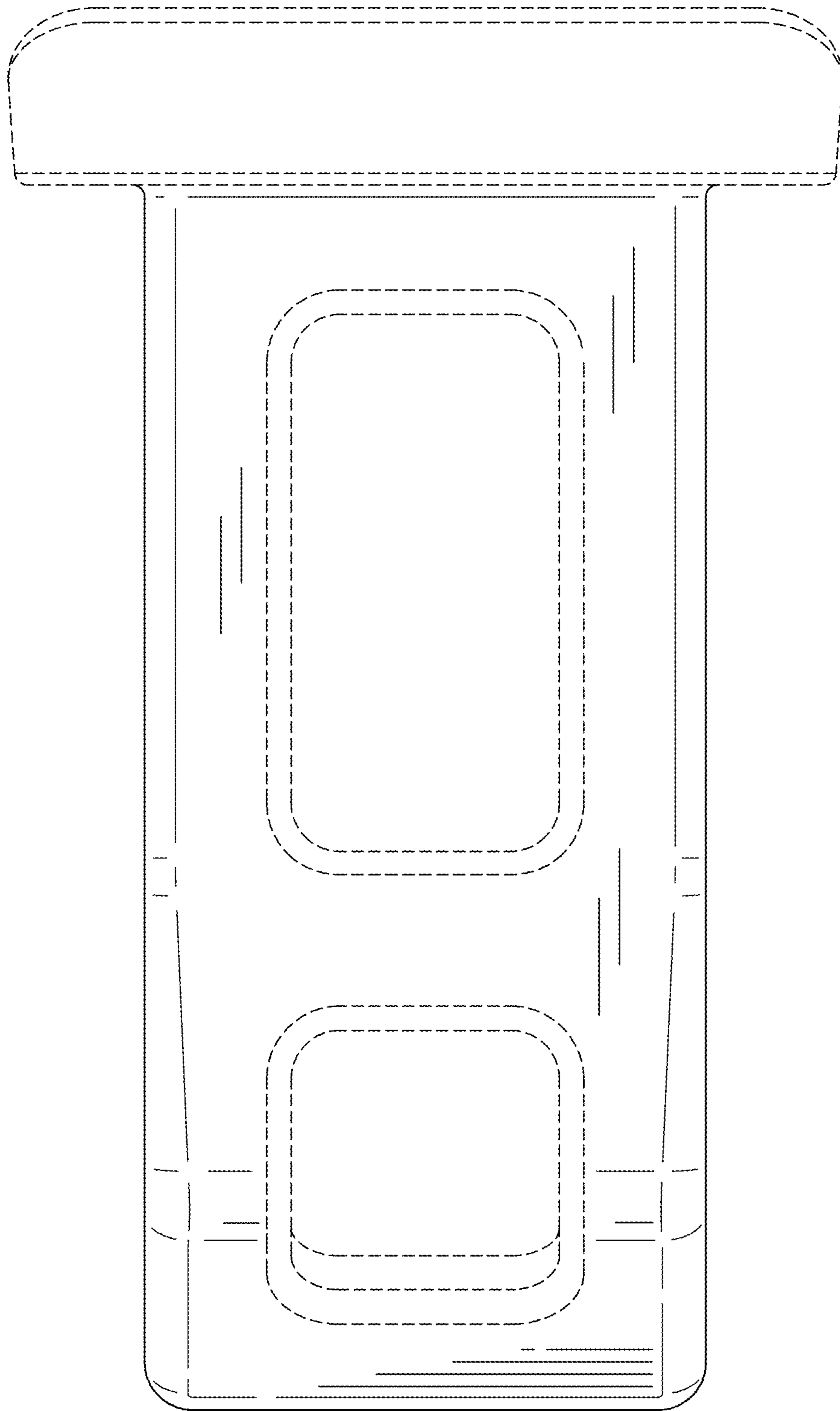

FIG. 9

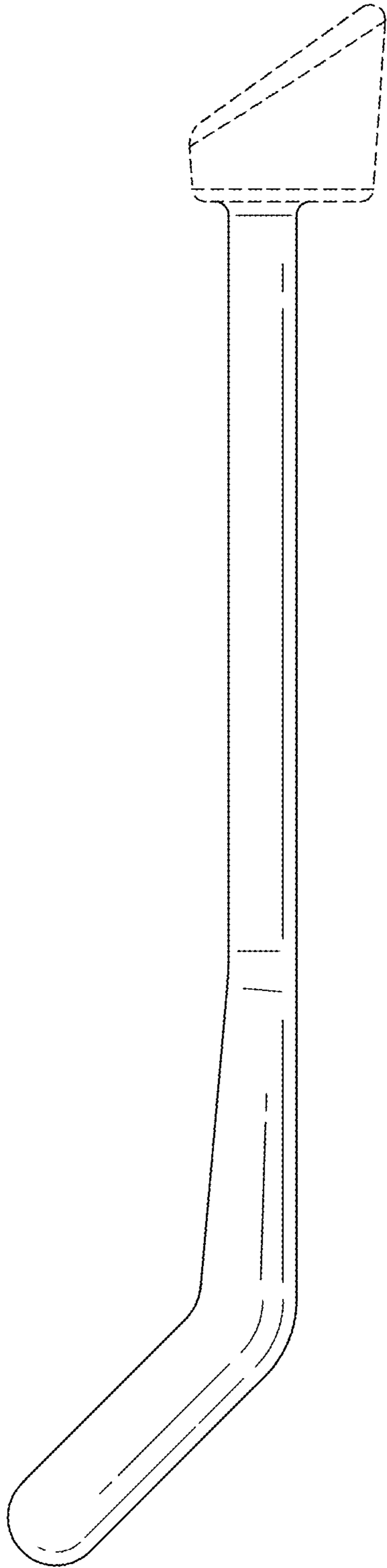

FIG. 10

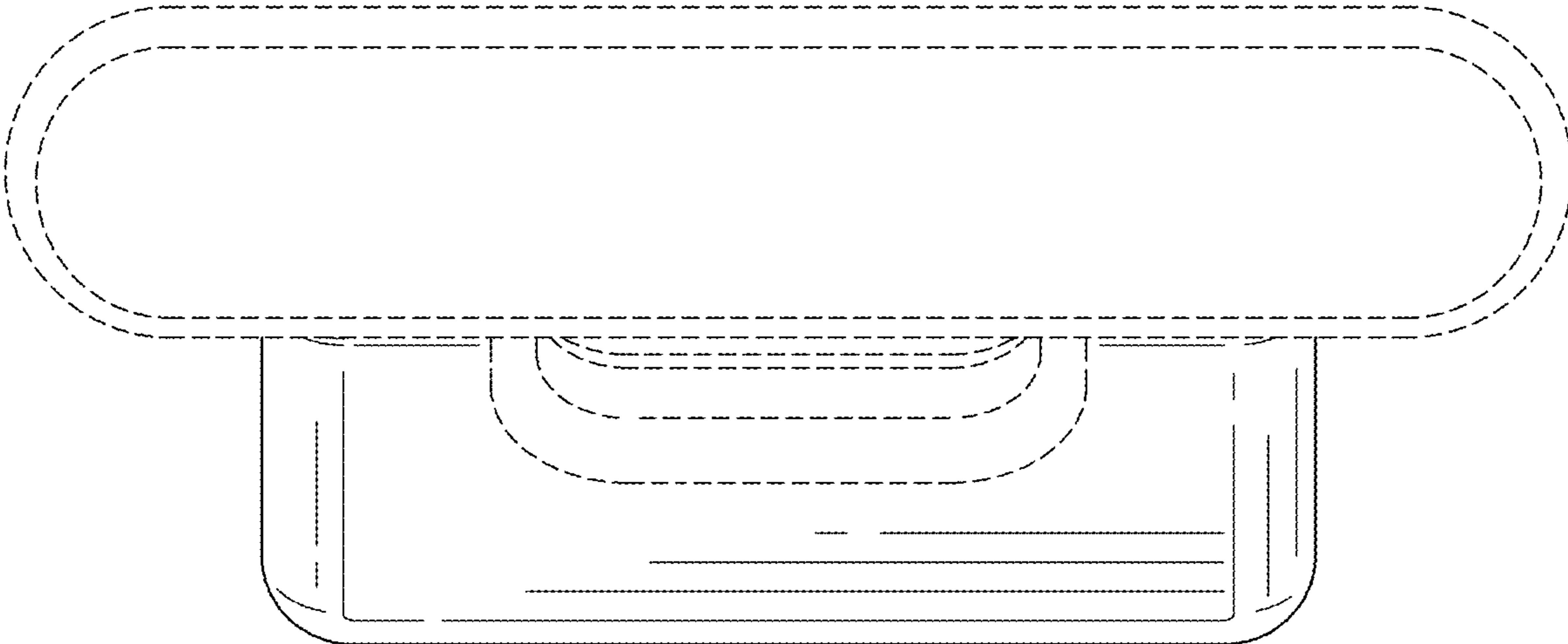

FIG. 11

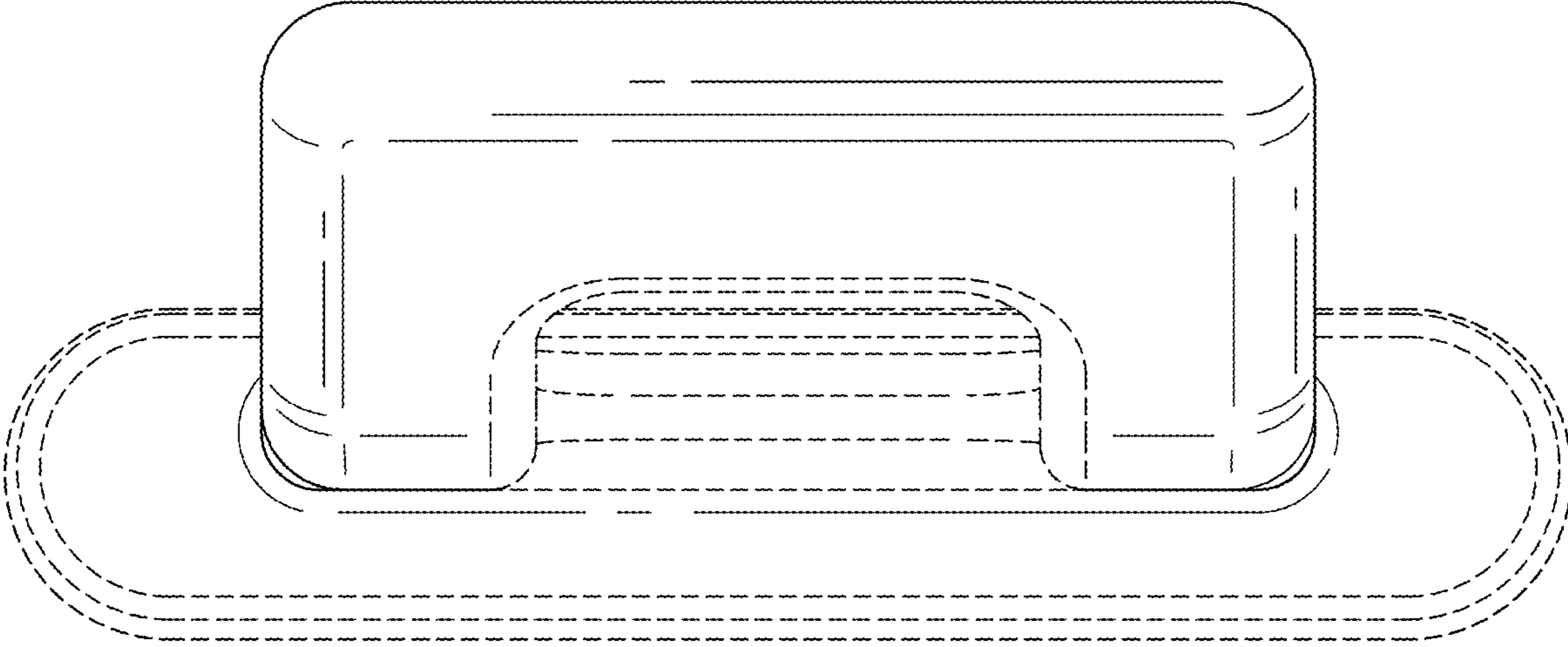

FIG. 12