



US00D933421S

(12) **United States Design Patent** (10) **Patent No.:** **US D933,421 S**
Kim et al. (45) **Date of Patent:** **** Oct. 19, 2021**

(54) **ROBOT ARM FOR PREPARING FOOD OR DRINK**

(71) Applicant: **LG ELECTRONICS INC.**, Seoul (KR)

(72) Inventors: **Yongkwon Kim**, Seoul (KR); **Dongyoun Kim**, Seoul (KR); **Jinhyeok Park**, Seoul (KR)

(73) Assignee: **LG ELECTRONICS INC.**, Seoul (KR)

(**) Term: **15 Years**

(21) Appl. No.: **35/509,507**

(22) Filed: **Nov. 29, 2019**

(80) **Hague Agreement Data**

Int. Filing Date: **Nov. 29, 2019**

Int. Reg. No.: **DM/205499**

Int. Reg. Date: **Nov. 29, 2019**

Int. Reg. Pub. Date: **May 29, 2020**

(51) **LOC (13) Cl.** **31-00**

(52) **U.S. Cl.**
USPC **D7/397; D7/213**

(58) **Field of Classification Search**
USPC D7/300, 301, 306, 309, 311, 312, 313, D7/332, 337, 339, 347, 348, 352, 362, D7/367, 368, 376, 377, 378, 379, 381, D7/383, 399, 407, 409, 510, 523, 543, D7/532, 538, 665, 213, 397; D15/199
CPC .. A47J 31/44; A47J 31/52; A47J 43/04; A47J 43/044
See application file for complete search history.

(56) **References Cited**

U.S. PATENT DOCUMENTS

D548,759 S * 8/2007 Kraft D15/199
D582,453 S * 12/2008 Davies D15/199

D582,454 S * 12/2008 Davies D15/199
D582,455 S * 12/2008 Davies D15/199
D582,456 S * 12/2008 Davies D15/199
D716,357 S * 10/2014 Gombert D15/199
D761,339 S * 7/2016 White, Jr. D15/199
D776,178 S * 1/2017 Ries D15/199
D776,715 S * 1/2017 Murata D14/492
D802,041 S * 11/2017 He D15/199
10,058,213 B2 * 8/2018 Fauteux A47J 37/1223
D830,439 S * 10/2018 Park D15/199
D837,853 S * 1/2019 Deng D15/199
D841,065 S * 2/2019 Hontani D15/199
D841,712 S * 2/2019 Hontani D15/199
D852,862 S * 7/2019 Dosho D15/199
D852,863 S * 7/2019 Dosho D15/199
D865,828 S * 11/2019 Bogart D15/199
D870,169 S * 12/2019 Dosho D15/199

(Continued)

OTHER PUBLICATIONS

Channel Wrap, date unknown, found on Aug. 24, 2021 at <https://www.zippertubing.com/products/wire-and-cable-bundling/pull-through-sleeving/channel-wrap-pfr> (Year: 2021).*

Primary Examiner — Karen S Acker

(74) *Attorney, Agent, or Firm* — Birch, Stewart, Kolasch & Birch, LLP

(57) **CLAIM**

The ornamental design for a robot arm for preparing food or drink, as shown and described.

DESCRIPTION

- 1. Robot arm for preparing food or drink
- 1.1 : Perspective
- 1.2 : Front
- 1.3 : Back
- 1.4 : Left
- 1.5 : Right
- 1.6 : Top
- 1.7 : Bottom
- 1.8 : Perspective view showing a state of use

1 Claim, 8 Drawing Sheets

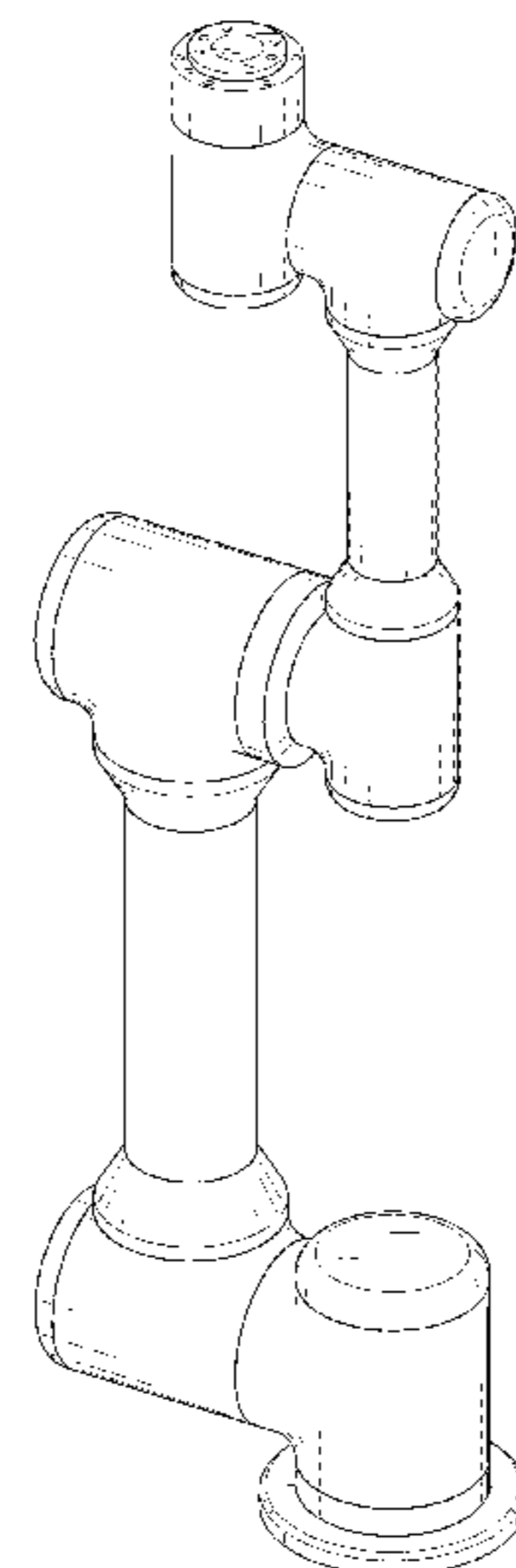

(56)

References Cited

U.S. PATENT DOCUMENTS

D873,417 S * 1/2020 Scott B25J 17/00
D24/185
D873,878 S * 1/2020 Vazquez D15/199
D882,655 S * 4/2020 Kouthoofd D15/199
D891,497 S * 7/2020 Kouthoofd D15/199
D892,885 S * 8/2020 Corkum B25J 18/00
D15/199
D906,392 S * 12/2020 Wappler A61B 1/0016
D15/199
D914,780 S * 3/2021 Hammers D15/199
D915,487 S * 4/2021 Sell D15/199
D916,916 S * 4/2021 Johnson D14/492
D921,733 S * 6/2021 Li A61B 90/40
D15/199
2005/0193901 A1 * 9/2005 Buehler A47J 44/00
99/468
2011/0107866 A1 * 5/2011 Oka B25J 17/00
74/490.03
2015/0119638 A1 * 4/2015 Yu A61B 1/0016
600/102
2015/0133960 A1 * 5/2015 Lohmeier A61B 90/40
606/130
2016/0331482 A1 * 11/2016 Hares A61B 34/35
2018/0207795 A1 * 7/2018 Haddadin B25J 18/00
2021/0220960 A1 * 7/2021 Schill B25J 19/022

* cited by examiner

1.1

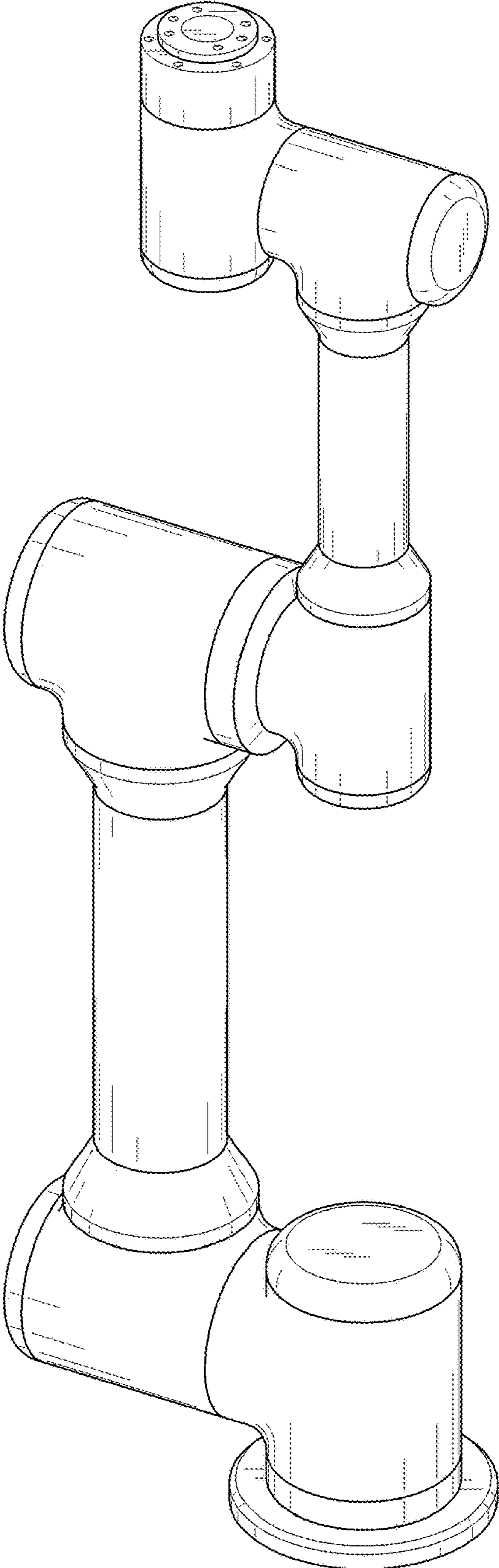

1.2

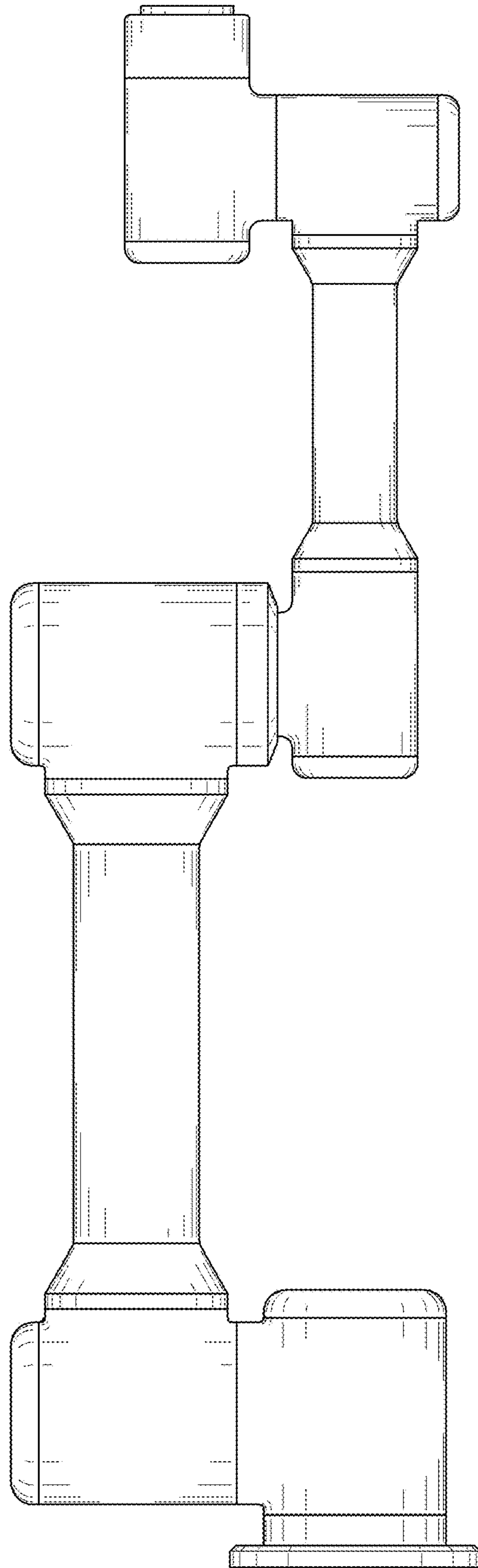

1.3

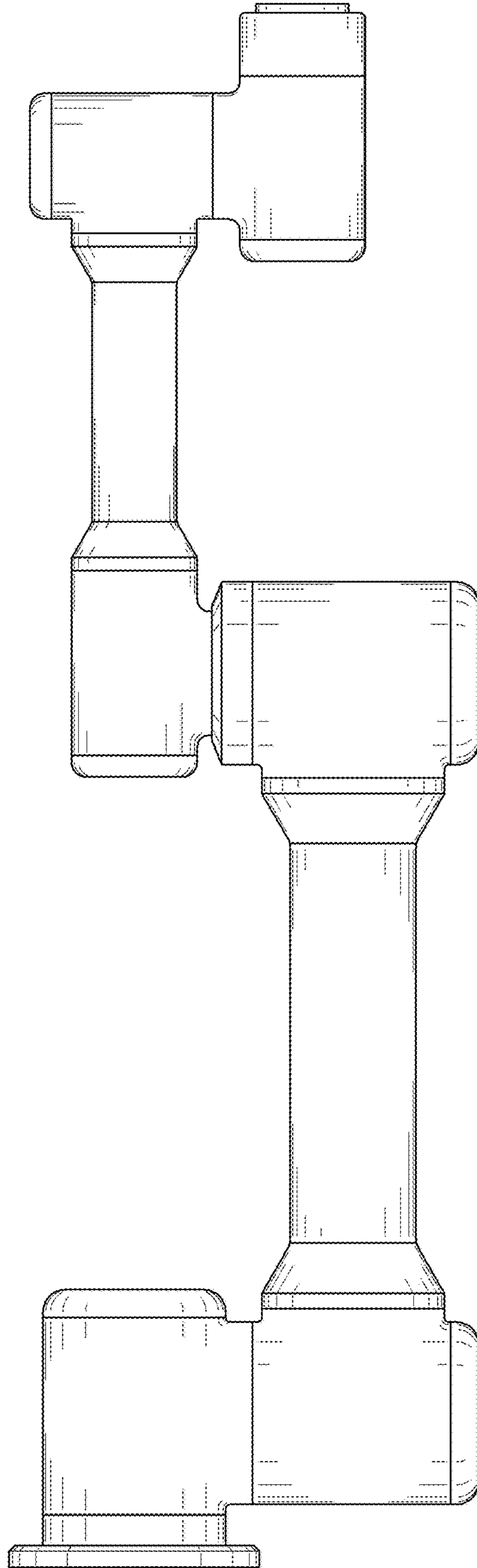

1.4

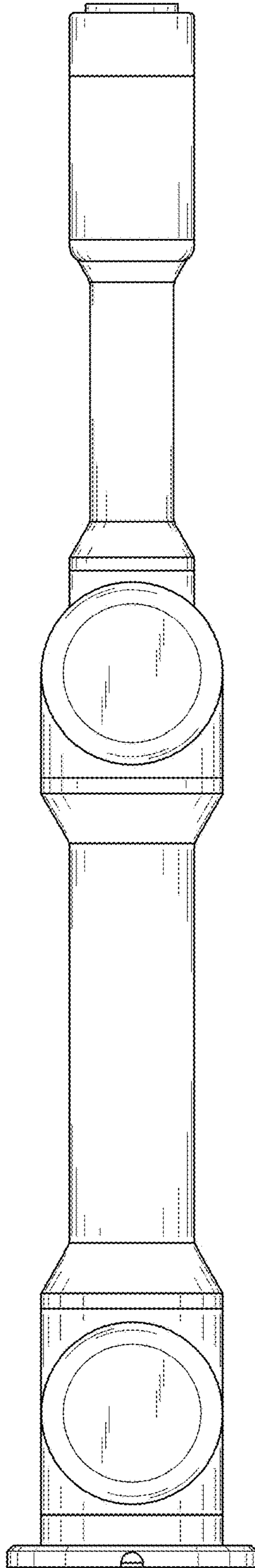

1.5

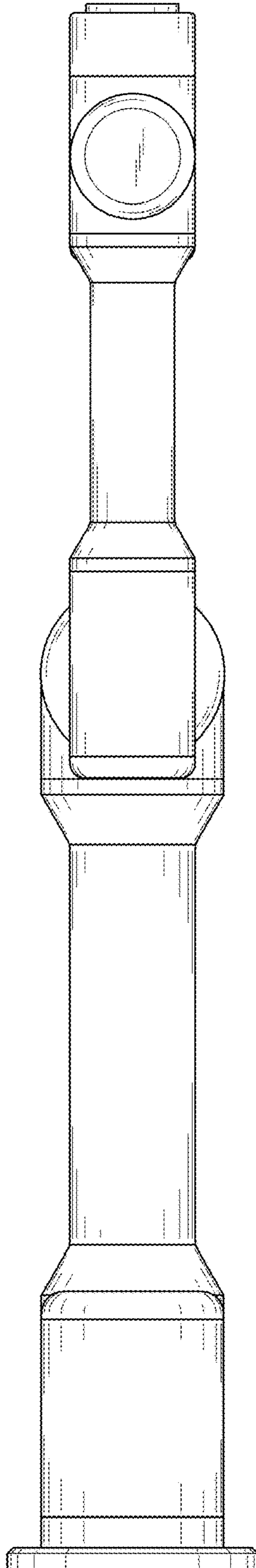

1.6

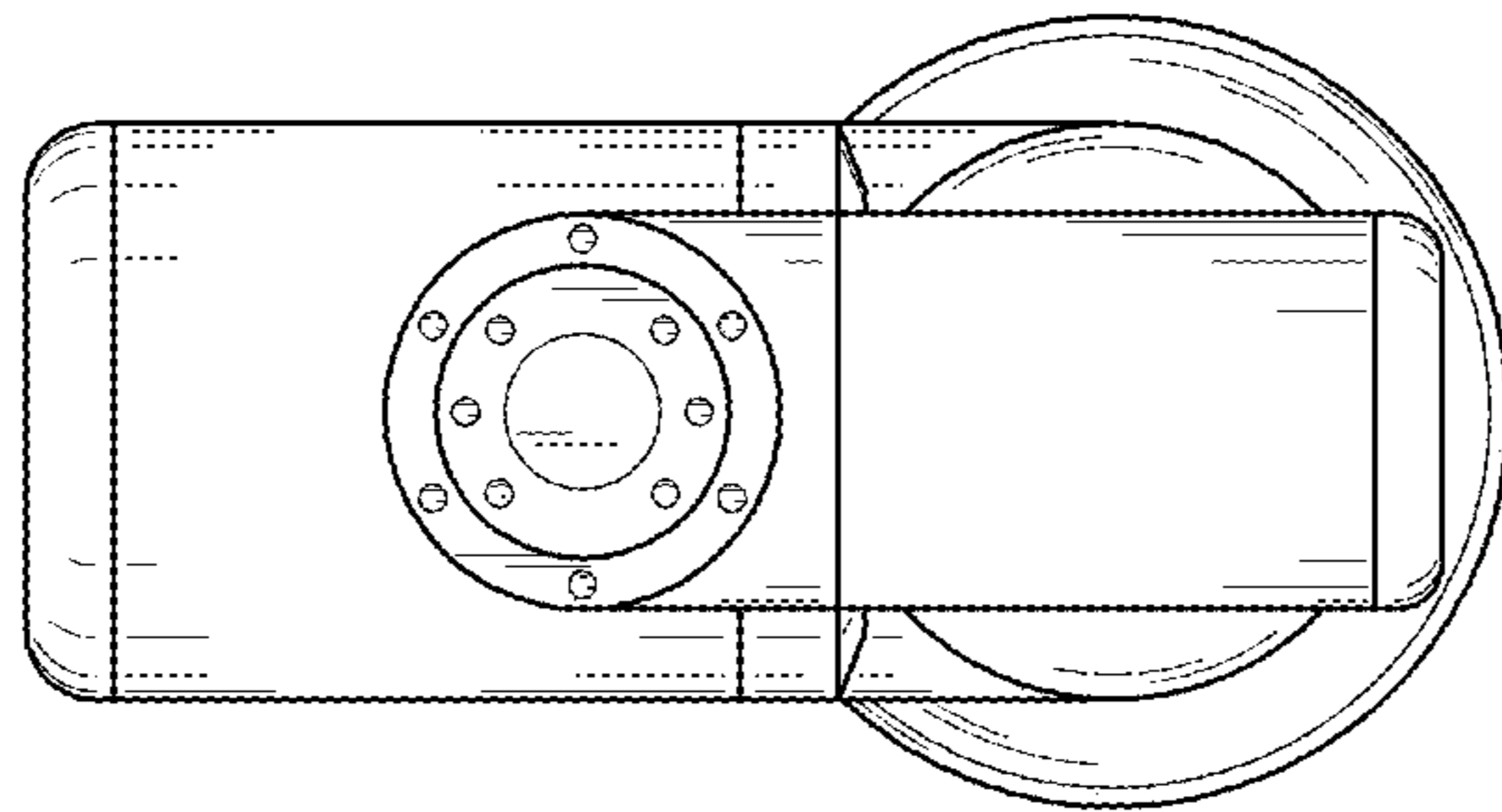

1.7

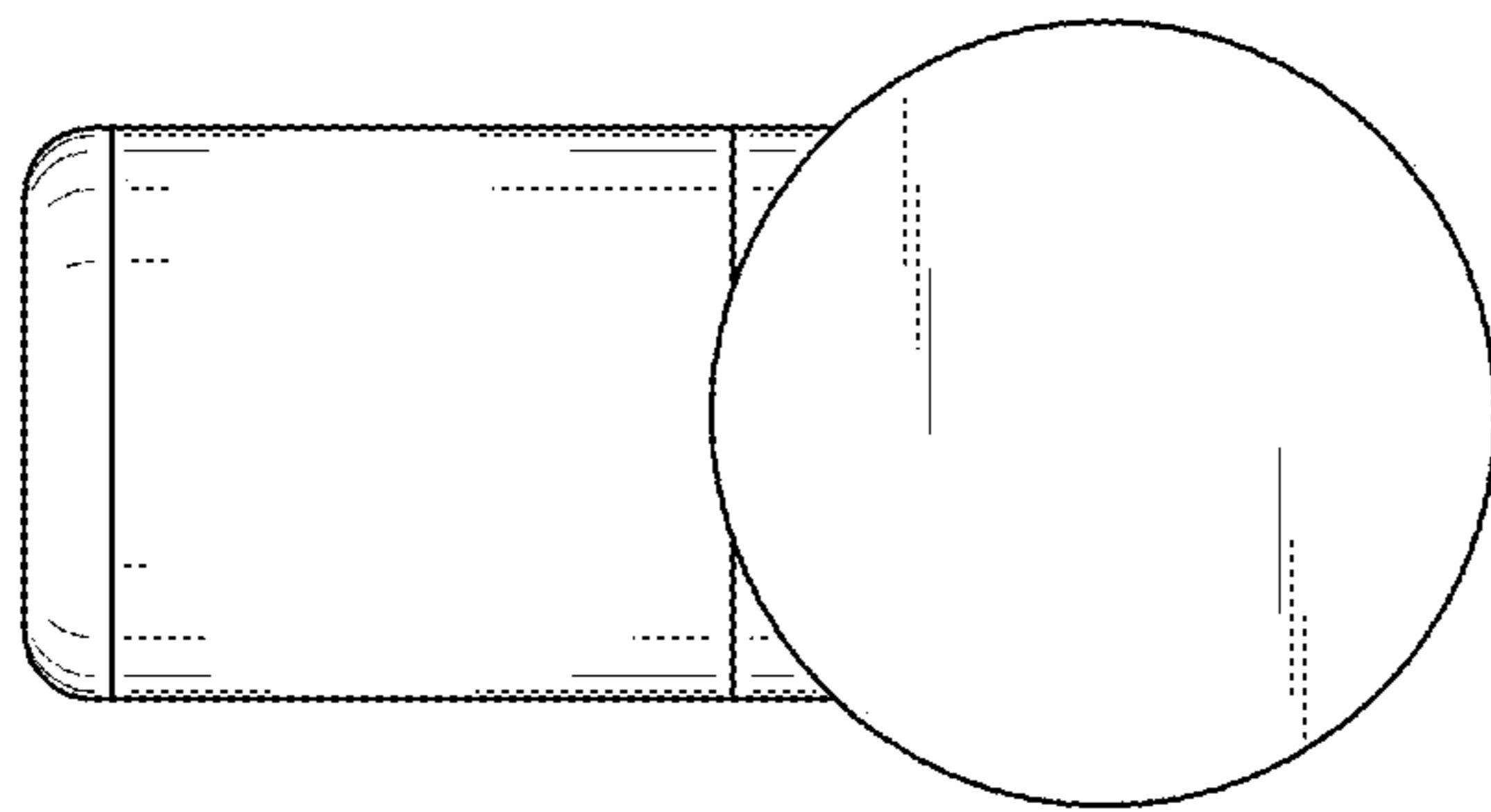

1.8

